

# FIG. 200

## SMOOTH BORE WELD PLATE MOUNT



### Smooth Bore Weld Plate Mount

**Size Range:** 1/4" outside diameter through 8.625" outside diameter

**Hardware:** 304 Stainless Steel, 316 Stainless Steel, or Electro-Zinc Plated Carbon Steel

**Plastic Inserts:** Polypropylene (blue)  
Santoprene (beige)  
Polyethersulfone (black)  
HDPE (white)  
High Temp Nylon (black)  
\*See page 85 for temperature ratings

**Installations:** Weld bottom plate to structure or supporting member, let cool before mounting plastic blocks.

**Thermal Expansion Guide:** (Optional) Provides for axial expansion of the tube or pipe due to thermal expansion. One set of two per clamp (See Fig. 207 in accessories)

**Thermal Expansion Guide Material:** Santoprene, 1/16" insert, Black for service identification

**200 Smooth Bore Weld Plate Mount - Part Number Configurator**

**Part Number Example:**

**SB T 7 2375 - PP**

**SB T 7 2375 - PP**

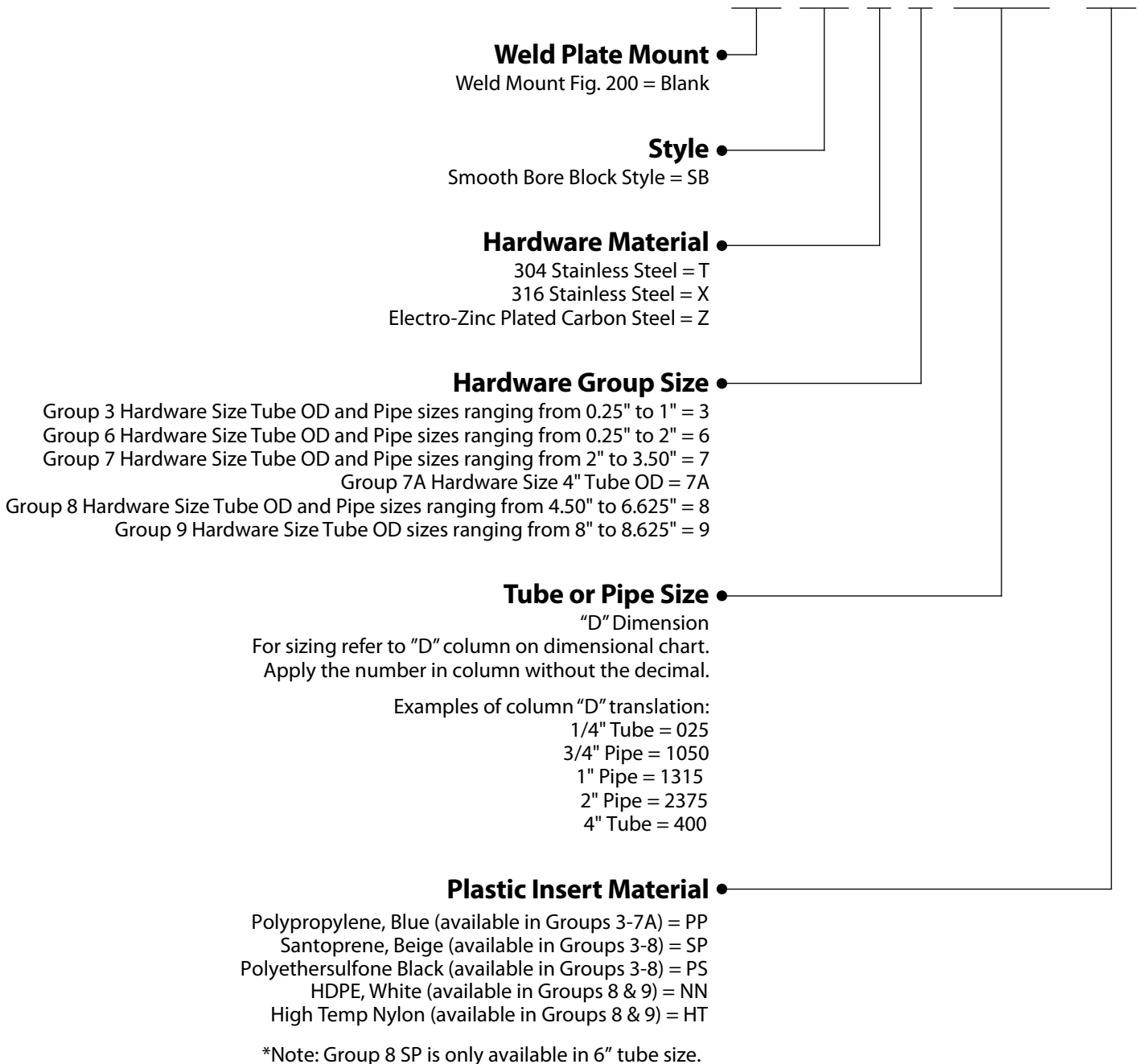

# FIG. 200

## SMOOTH BORE WELD PLATE MOUNT

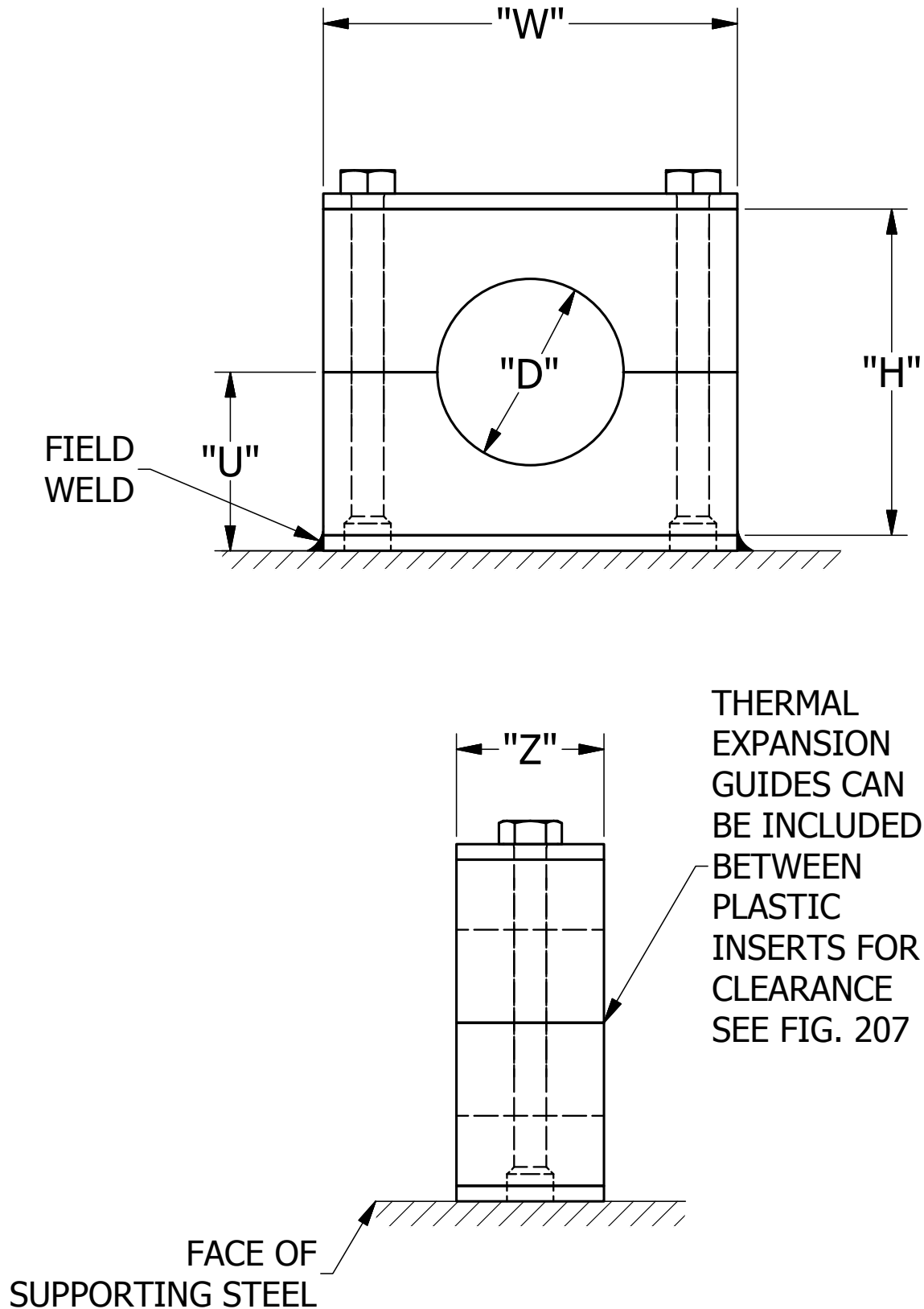

# FIG. 200

## SMOOTH BORE WELD PLATE MOUNT

GRP NO.	TUBE OR PIPE SIZE	"D" INCHES	W	H	Z	U	BOLT SIZE	LBS.
3	1/4 T	0.250	1.88" (48 mm)	1.38" (35 mm)	1.22" (31 mm)	0.81" (20 mm)	1/4-20	0.4 (0.18 kg)
	3/8 T	0.375						
	1/2 T	0.500						
	3/4 T	0.750						
	1/2 P	0.840						
	1 T	1.000						
6	1/4 T	0.250	3.34" (85 mm)	2.63" (67 mm)	1.22" (31 mm)	1.44" (37 mm)	1/4-20	0.6 (0.27 kg)
	3/8 T	0.375						
	1/2 T	0.500						
	5/8 T	0.625						
	3/4 T	0.750						
	1/2 P	0.840						
	7/8 T	0.875						
	1 T	1.000						
	3/4 P	1.050						
	1-1/4 T	1.250						
	1 P	1.315						
	1-1/2 T	1.500						
	1-1/4 P	1.660						
	1-1/2 P	1.900						
2 T	2.000							
7	2 T	2.000	5.02" (128 mm)	4.38" (111 mm)	1.22" (31 mm)	2.31" (59 mm)	1/4-20	1.1 (0.50 kg)
	2 P	2.375						
	2-1/2 T	2.500						
	2-1/2 P	2.875						
	3 T	3.000						
	3-1/2 T -3 P	3.500						
7A	4 T	4.000	5.77" (147 mm)	4.80" (122 mm)	1.22" (31 mm)	2.54" (65 mm)	1/4-20	1.5 (0.68 kg)
8	6 T	6.000	8.88" (226 mm)	7.65" (194 mm)	1.50" (38 mm)	4.01" (102 mm)	3/8 - 16	4.4 (1.99 kg)
	6P	6.625						
9	8T	8.000	12.50" (318 mm)	10.00" (254 mm)	1.75" (44 mm)	5.38" (137 mm)	5/8 - 11	12.5 (5.70 kg)
	8P	8.625						

# FIG. 200

## SMOOTH BORE WELD PLATE MOUNT



**Figure 200  
Weld Plate Mount**

HEX

COP

CLH (pair)

STW