

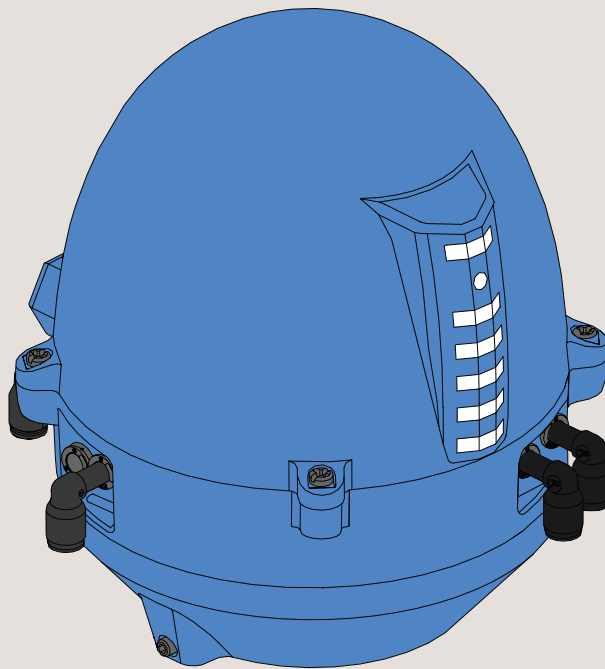

Instruction Manual

ThinkTop® Digital, AS-Interface and DeviceNet



Patented Sensor System
Registered Design
Registered Trademark

ESE02952-EN3 2022-10

Original manual

The information herein is correct at the time of issue but may be subject to change without prior notice

1. Declarations of Conformity	4
2. Safety	6
2.1. Important information	6
2.2. Warning signs	6
2.3. Safety precautions	6
3. General information	7
3.1. ThinkTop at a glance	7
3.2. Recycling information	7
4. Technical specifications	8
4.1. ThinkTop common specifications	8
4.2. ThinkTop Digital	10
4.3. ThinkTop, AS-Interface	11
4.4. ThinkTop DeviceNet	13
5. Installation	16
5.1. Installation on air actuators	16
5.2. Installation on Series 700 valves	19
5.3. Air connections	21
5.4. Electrical connection, internal - Digital 24 VDC	22
5.5. Example of using common power supply	22
5.6. Electrical connection, internal - AS-Interface	23
5.7. Electrical connection, internal - DeviceNet	24
6. Setup diagram	25
6.1. ThinkTop setup- utilising local 'I' and 'II' keys	25
6.2. ThinkTop setup- utilising IR keypad	28
6.3. ThinkTop quick setup guide	30
7. Fault finding	32
7.1. Fault finding and LEDs	32
8. Maintenance	34
8.1. Dismantling ThinkTop	34
8.2. Assembly of ThinkTop	35
8.3. Dismantling and assembling Series 700 valves	37
9. Parts list	39
9.1. Diagrams for ThinkTop	39
9.2. ThinkTop	40
9.3. Diagrams for ThinkTop: Series 700	43
9.4. ThinkTop: Series 700	44

1 Declarations of Conformity

EU Declaration of Conformity

The Designated Company

Alfa Laval Kolding A/S, Albuen 31, DK-6000 Kolding, Denmark, +45 79 32 22 00

Company name, address and phone number

Hereby declare that

Top Unit for Valve Control and Indication

Designation

ThinkTop® Basic Digital 10 - 30 VDC

Type

is in conformity with the following directives with amendments:

- EMC Directive 2014/30/EU
- RoHS Directive 2011/65/EU and amendments

The person authorised to compile the technical file is the signer of this document.

Global Product Quality Manager

Title

Lars Kruse Andersen

Name

Kolding, Denmark

Place

2022-10-01

Date (YYYY-MM-DD)

Signature

This Declaration of Conformity replaces Declaration of Conformity dated 2017-03-01



1 Declarations of Conformity

UK Declaration of Conformity

The Designated Company

Alfa Laval Kolding A/S, Albuen 31, DK-6000 Kolding, Denmark, +45 79 32 22 00

Company name, address and phone number

Hereby declare that

Top Unit for Valve Control and Indication

Designation

ThinkTop® Basic Digital 10 - 30 VDC

Type

is in conformity with the following directives with amendments:

- The Electromagnetic Compatibility Regulations 2016
- The Restriction of the Use of Certain Hazardous Substances in Electrical and Electronic Equipment Regulations 2012

Signed on behalf of: Alfa Laval Kolding A/S

Global Product Quality Manager

Title

Lars Kruse Andersen

Name

Kolding, Denmark

Place

2022-10-01

Date (YYYY-MM-DD)

Signature

DoC Revison_01_102022

**UK
CA**

2 Safety

*This manual highlights unsafe practices and other important information are emphasised in this manual.
Warnings are emphasised by means of special signs. All warnings in the manual are summarised on this page.
Pay special attention to the instructions below in order to avoid severe personal injury or damage to the top unit are avoided.*

2.1 Important information

Always read the manual before using the top unit!

WARNING

Indicates that special procedures must be followed to avoid serious personal injury.

CAUTION

Indicates that special procedures must be followed to avoid damage to the ThinkTop.

NOTE

Indicates important information to simplify or clarify procedures.

2.2 Warning signs

General warning:



Dangerous electrical voltage:



Caustic agents:



2.3 Safety precautions

Installation:

Always read the technical data carefully

Never install the ThinkTop before the valve or relay are in a safe position

If welding close to the ThinkTop: **Always** perform earthing close to the welding area

Disconnect the ThinkTop.



Always ensure the ThinkTop electrically connected by authorised personnel



Maintenance:

Always read the technical data carefully

Always fit the seals between the valve and ThinkTop correctly

Never service the ThinkTop before the valve or relay are in a safe position

Never service the ThinkTop when the valve/actuator under pressure

Never clean the ThinkTop using high pressure cleaning equipment

Never use cleaning agents that will erode the exterior of the ThinkTop. Check with your cleaning agent supplier



3.1 ThinkTop at a glance

The ThinkTop is designed to ensure optimum and reliable valve control in conjunction with Alfa Laval valves and is compatible with most PLC systems (Programmable Logic Controllers).

The ThinkTop can be equipped with 0-3 solenoid valves. The solenoids are electrically controlled by the PLC system and, when activated, the compressed air is activating the air actuator. Depending on the type of control unit, the primary solenoid valve can be provided with a built-in throttle function on both the air inlet and outlet, which means that it is possible to control the opening and closing time of the air actuator. The solenoids are also equipped with a manual hold override.

Visual LED lights constantly indicate the distinct status of the control unit: such as valve positions, solenoid valve energised, setup and local fault indication etc.

The ThinkTop is characterised by its high durability, well-proven features and modular design. It is exchangeable and is ready to fit Alfa Laval Sanitary actuators from the past and present.

3.2 Recycling information

• Unpacking

- Packing material consists of wood, plastics, cardboard boxes
- Wood and cardboard boxes can be reused, recycled or used for energy recovery
- Plastics should be recycled or burnt at a licensed waste incineration plant

• Maintenance

- All metal parts should be sent for material recycling
- Worn or defective electronic parts should be sent to a licensed handler for material recycling
- All non-metal wear parts must be handled in compliance with local regulations

• Scrapping

- End-of-life, the equipment shall be recycled according to relevant, local regulations. In addition to the equipment itself, any hazardous residue from the process liquid must be taken into account and handled in the necessary way. When in doubt, or in the absence of local regulations, please contact the local Alfa Laval sales company
-

4 Technical specifications

4.1 ThinkTop common specifications

Sensor System

Unique “No Touch” sensor system with no mechanical sensor adjustments. A magnet (indication pin) is mounted on the valve stem and the translatory change in the magnetic field vectors are detected by the sensor board with a measuring accuracy of $\pm 0.1\text{mm}$.

Electrical connection:

Direct main cable gland entry (hard wired) PG11 ($\varnothing 4 - \varnothing 10\text{ mm}$).

Option: external sensor cable gland entry PG7 ($\varnothing 3 - \varnothing 6.5\text{ mm}$).

Option for AS-i version: Main connection as M12 plug, 2 wire.

The terminal row of the sensor unit is equipped with screw terminals for both internal and external cables and wires. The terminals are suitable for wires up to 0.75 mm^2 (AWG 19).

External sensors

The external sensors are used for seat-lift supervision when seat-lift can not be internally detected. The sensors obtain their supply voltage from the terminal row. The output signals from the sensors are connected to two inputs on the terminal row on the internal sensor unit. If the actual setup is set for internal seat-lift, the corresponding external signal is not used, otherwise the external signal logically controls the corresponding feedback to the PLC (Programmable Logic Controller).

Note! If using an external sensor, the sensor must be active/activated when performing a setup routine of the control head.

Supply voltage: Must match the selected type of ThinkTop.

Supply current: Max. 15 mA per sensor.

Type of sensor: VDC, only 3-wire sensor PNP.

Sensor cable length: Max. 3 m.

Suitable external sensors, brackets and cable glands for setting up upper seat-lift defection on mixproof valves are available as accessories in the catalogue.

ThinkTop Visual Indications

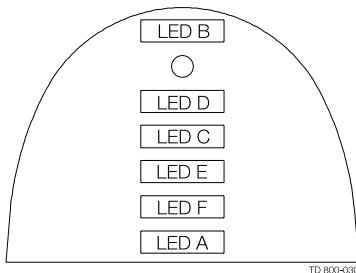

LED Indications

LED B	“Open valve” (Yellow)
O	IR-Receiver
LED D	“Setup/Internal fault” (Red)
LED C	“Seat-lift 1/2” (Yellow)
LED E	“Solenoid valves” (Green)
LED F	“Maintenance” (Orange)
LED A	“Closed valve” (Yellow)

Status signal

The status signal is used for four purposes:

- To indicate that setup is in progress + (LED D).
- To indicate an error condition + (LED D). (Flashing LED = software error), (steady LED = hardware error).
- To indicate maintenance due to the self adjustment programme + (LED F).
- To indicate that the time for maintenance has been reached + (LED F).

4 Technical specifications

Technical specifications	
Up to 3 solenoid valves in each unit.	
Type	3/2 or 5/2 valve (only possible with one 5/2 valve)
Air supply	300-900 kPa (3-9 bar)
Filtered air, max. particles or dirt	5 μ 5-5 mg/m ³
Max. flow	180 l/min
Max. oil content	1 mg/m ³
Max. water content	0.88 g/m ³ -20 °C compressed air
Throughput	ø2.5 mm
Air restriction (throttle function) air inlet/outlet.	Yes. (solenoid valve 1 only)
Manual hold override.	Yes
Throttle, air in/out 1A, 1B	0-100%
External air tube connection	ø6 mm or 1/4" (specify when ordering)
Silencer/filter	Connection possible via ø6 mm (Filter recommended in tropical regions)
Materials	
Plastic parts	Nylon PA12.
Metal parts	Stainless steel and Brass.
Seals	Nitrile (NBR).
Gore vent. membrane	PBT plastic.

Micro environment demand specifications

Temperature		
Working:	-20°C to +85°C	IEC 68-2-1/2
Storage:	-40°C to +85°C	IEC 68-2-1/2
Temperature change:	-25°C to +70°C	IEC 68-2-14
Vibration		
	10-55 Hz, 0.7 mm	IEC 68-2-6
	55-500 Hz, 10g	
	3 x 30 min, 1 octave/min	
Drop test		
		IEC 68-2-32
Humidity		
Constant humidity:	+40°C, 21 days, 93% R.H.	IEC 68-2-3
Cyclic humidity:	+25°C/+55°C	
	12 cycles	IEC 68-2-30
(working)	93% R.H.	
Protection class		
	IP66 and IP67	IEC 529
Input threshold		
Voltage/current:	Type 1 input requirements	EN 61131-2
EMC Directive		
	2014/30/EU	
UL Approval		
	8-30 VDC, Class 2 input, 45 mA max. output	UL 508-E203255

4 Technical specifications

4.2 ThinkTop Digital

Power Supply

The ThinkTop is designed to be a part of the PLC's Input/Output (I/O) system. It should be supplied from the same protected power supply as the other I/O devices. The I/O power supply should not be used for other kinds of load.

The unit is reverse polarity and short circuit protected.

Supply voltage nominal: 24 ± 10% VDC

Supply voltage absolute max.: 30 VDC.

Supply voltage absolute min.: 8 VDC.

Supply current*): Max. 45 mA (for sensor unit alone)
(excluding current to the solenoids, external sensor and the PLC input current).

*) The initial current during power-on is higher. The actual shape of the current pulse depends on the power supply used. Typical values are 150 mA RMS during 13 ms (regulated PS) to 360 mA RMS during 8 ms (unregulated PS).

Fulfillment of the UL requirements in UL508 requires the unit to be supplied by an isolating source that complies with the requirements for class 2 power units (UL1310) or class 2 and 3 transformers (UL1585).

Feedback signals

The sensor system can be used for 4 feedback signals + 1 status signal = 5 digital PNP/NPN feedback signals.

Output signals from the sensor unit to the connected PLC.

Nominal voltage: Must match the selected type of ThinkTop.

Load current: Typically 50 mA, max. 100 mA .

Voltage drop: Typically 3 V at 50 mA.

PNP/NPN Polarity

PNP (sourcing) or NPN (sinking) function is selected with a jumper in term. 12 and 13. Jumper present = PNP. If changing to NPN, remove the jumper and make a power recycle. A power recycle is always required when changing this function.

Solenoid valve signals

Three output signals (with one common, terminal 11) from the terminal row are used for activation of the solenoids. Positive (connected with terminal 9) or negative.

Technical specifications	
Nominal voltage	24 VDC
Nominal power	1.0 W.

4.3 ThinkTop, AS-Interface

Feedback signals

Power Supply

The power supply to the complete unit is taken from the AS-Interface loop. The unit is reverse polarity protected.

Supply voltage: 29.5 - 31.6 VDC

Normal current consumption sensor

board 45 mA (excluding current for the solenoids and the external sensor).

Max. current consumption sensor

board 165 mA (if external devices e.g. solenoids and switches are connected to the sensor board, a higher current consumption than 120 mA may occur, which this will damage the sensor boards).

Feedback signals

Signals transmitted through the AS-Interface BUS to the AS-Interface master PLC.

The sensor system can be used for 3 feedback signals + 1 status signal = 4 feedback signals.

Slave profile options: (specify when ordering)

Slave profile v.2.1

Default slave address: 0

IO code: 7 (4 bit bi-directional)

IO code: F (slave without profile)

ID1 code: F

ID2 code: F

Slave profile = S-7.F.F.F

No. of slaves:

AS-Interface specification 2.1 for max. 31 ThinkTop units on a single master/gateway

Slave profile v.3.0

Default slave address: 0

IO code: 7 (4 bit bi-directional)

IO code: A

ID1 code: 7

ID2 code: 7

Slave profile = S-7.A.7.7

No. of slaves:

AS-Interface specification 3.0 for max. 62 ThinkTop units on a single master/gateway.

4 Technical specifications

AS-Interface bits assignment:

For the AS-Interface version with 31 and 62 nodes, the following bit assignment will be used:

DI 0 De-Energised position (closed position)
DI 1 Energised position (open position)
DI 2 SeatLift 1 and 2 position (sum SeatLift signal)
DI 3 Status

DO 0 Not connected
DO 1 Solenoid valve 1
DO 2 Solenoid valve 2
DO 3 Solenoid valve 3

Solenoid valve signals

Signals transmitted through the AS-Interface BUS to the AS-Interface master PLC.

Technical specifications	
Nominal voltage	24 VDC
Nominal power	1.0 W

4.4 ThinkTop DeviceNet

DeviceNet features and functionality

Network size	Up to 63 nodes	
Network length	Selectable end-to-end network distance varies with speed	
	Baud Rate	Distance
	125 Kbps	500 m (1,640 ft)
	250 Kbps	250 m (820 ft)
	500 Kbps	100 m (328 ft)
Data packets	0-8 bytes	
Bus topology	Linear (trunk line/drop line); power and signal on the same network cable	
Bus addressing	Peer-to-peer with multi-cast (one-to-many); multi-master and master/slave special case; polled or change-of-state (exception-based)	
System features	Removal and replacement of devices from the network under power	

The basic trunk-line/drop-line topology provides separate twisted-pair buses for both signal and power distribution. A thick or thin cable can be used for either trunk lines or drop lines. End-to-end network distance varies with data rate and cable size

Data rates	125 Kbps	250 Kbps	500 Kbps
Thick trunk length	500 m (1,640 ft)	250 m (820 ft)	100 m (328 ft)
Thin trunk length	100 m (328 ft)	100 m (328 ft)	100 m (328 ft)
Maximum drop length	6 m (20 ft)	6 m (20 ft)	6 m (20 ft)
Cumulative drop length	156 m (512 ft)	78 m (256 ft)	39 m (128 ft)

The end-to-end network distance varies with data rate and cable thickness.

DeviceNet requires a terminating resistor to be installed at each end of the trunk:

- 121 ohm
- 1% metal film
- 1/4 watt

Terminating resistors should not be installed at the end of a drop line, only at the two ends of the trunk-line.

For further information please refer to the DeviceNet Standard.

DeviceNet Features

Device type	Generic	Master/scanner	N
Explicit peer-to-peer messaging	N	I/O Slave messaging	
I/O peer-to-peer messaging	N	• Bit strobe	N
Configuration consistency value	N	• Polling	Y
Faulted node recovery	N	• Cyclic	N
Baud rates	125K, 250K, 500K	• Change of state (COS)	N
Configuration method	EDS		

The end-to-end network distance varies with data rate and cable thickness.

4 Technical specifications

DeviceNet interface

Baud rates: 125K, 250K and 500K.

Polling I/O slave messaging.

Poll: 1 bytes.

1 bytes = Input/outputs and alarms (class 4).

Node address

Range: 0-63.

Default slave address: 63.

Power supply

The power supply to the complete unit is taken from the DeviceNet.

Supply voltage: 11-25 V DC, as specified for the DeviceNet.

Supply current: Max. 45 mA (for sensor unit alone)
(excluding current to the solenoids and the external proximity switches).

ThinkTop DeviceNet features

Feedback signals

Input signals (produced by the sensor unit) transmitted over the DeviceNet - class 4.

Five feedback signals: closed valve, open valve, seatlift 1, seatlift 2 and status.

The status signal is used for five purposes:

- To indicate that a setup is in progress (LED D).
- To indicate an error condition (LED D), (flashing = software error), (steady = hardware error).
- To indicate that maintenance is required (LED F).
- To indicate whether there is a conflict in the self adjustment programme (LED F).
- To indicate whether any communication exists between ThinkTop® and PLC (LED D, steady).

Solenoid signals

Output signals received from the DeviceNet.

Three bits to control the solenoid drives located in the sensor unit.

ThinkTop EDS file

The EDS file can be downloaded from www.alfalaval.com by searching "ThinkTop" at the top of the main landing page. On the ThinkTop landing page, choose Documentation in the menu and find the EDS package. Alternatively, both the EDS file and further information on DeviceNet can be found at www.odva.org

ThinkTop DeviceNet attribute list

Name			Path			R/W/CS	data type	Raw data	
	Class	Inst	dec.	hex.	"poll"			len.	LSB
Release DNET 4.6	4	1	3	-	-	R	Byte	1	-
Valve value	4	3	3	-	-	R/W	Byte	1	-

ThinkTop DeviceNet attribute list

Name	Eng.	Units	Conv.	Bit maps/data			
	mult.	divisor	units	byte 1	byte 2	byte 3	byte 4
Release DNET 4.6	-	-	-	PLC_image	-	-	-
Valve value	-	-	-	Solenoids	-	-	-

ThinkTop DeviceNet bit mappings

PLC_Image								
Valve value	x	x	x	Maint.	SL2	SL1	OPEN	CLOSED
Solenoid 1, 2 & 3 (Valve command)	x	x	x	x	Coil #3	Coil #2	Coil #1	x

ThinkTop DeviceNet Poll command structures

Poll request message format

byte	bit							
	7	6	5	4	3	2	1	0
0	x	x	x	x	Coil #3 de-energise	Coil #2 de-energise	Coil #1 de-energise	x

Poll response message format

byte	bit							
	7	6	5	4	3	2	1	0
0	Travel in Progress	Timer Expired	x	MAINT. ERROR	Seat #2 Status	Seat #1 Status	OPEN Status	CLOSED Status

Typical power consumption

Test conditions: One ThinkTop DeviceNet connected to the network with 1 input (on) and:

No solenoids on	supply voltage 25 VDC	20 mA
1 solenoid active (PWM)	supply voltage 25 VDC	28 mA
2 solenoid active (PWM)	supply voltage 25 VDC	36 mA
3 solenoid active (PWM)	supply voltage 25 VDC	44 mA
No solenoids on	supply voltage 11 VDC	34 mA
1 solenoid active (PWM)	supply voltage 11 VDC	58 mA
2 solenoid active (PWM)	supply voltage 11 VDC	82 mA
3 solenoid active (PWM)	supply voltage 11 VDC	106 mA

5 Installation

5.1 Installation on air actuators

Step 1



Always read the technical data carefully.



Always ensure the ThinkTop is electrically connected by authorised personnel.

Step 2

1. Fit the air fittings on the actuator if not mounted.
2. Fit the activator stem (magnet) and tighten **carefully** with a spanner.

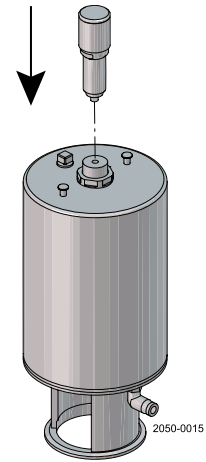

Step 3

1. Place the ThinkTop on top of the actuator.
2. Make sure X-ring is mounted.

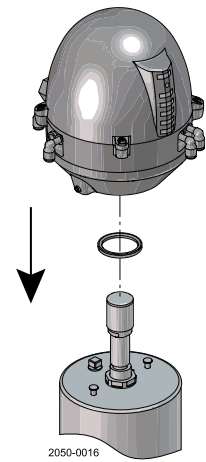

Step 4

1. Ensure that the unit is correctly mounted by **pressing** down on top of the ThinkTop.
2. Cross tighten the two Allen screws carefully in the two opposite directions.
3. Turn the actuator so that the LEDs are at the front

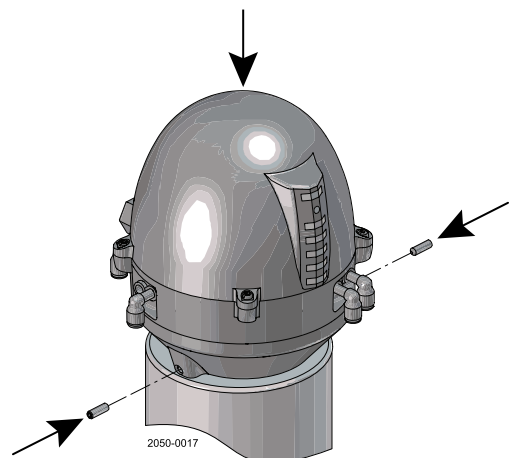

Step 5

Install the air tubes with reference to the Air connections diagram on page 21

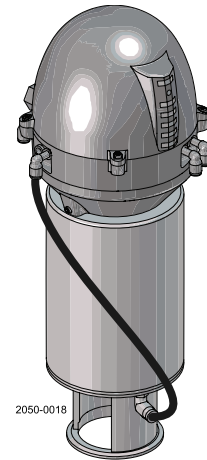

Step 6

Untaxen die vier Schrauben und ziehen Sie das ThinkTop-Gehäuse ab.

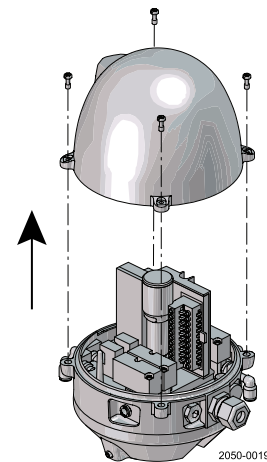

Step 7a - Cable gland version

1. Install cable (if not present) through the cable gland.
2. Connect the electrics of the ThinkTop (see 5.4 Electrical connection, internal - Digital 24 VDC).

NOTE!

Make sure the cable gland is fully tightened.

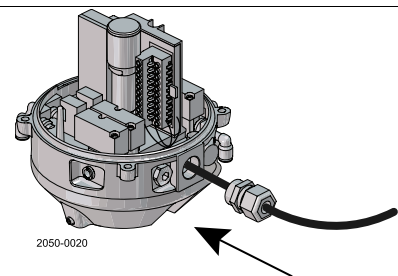

Step 7b - M12 plug version

1. Install M12 socket cable.

NOTE!

M12 plug Electrical connection:

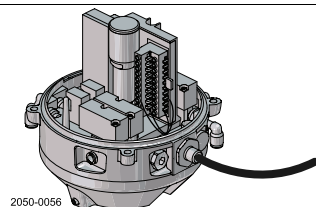
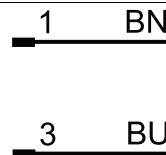
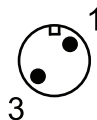

5 Installation

Step 8

Set up the ThinkTop (see chapter 6 Setup diagram).

NOTE!

The unit can be set up by the internal push buttons on the sensor board. To energise the valve, use manual hold override on the solenoids valve or ensure you are in radio contact with the control room.

5.2 Installation on Series 700 valves

Step 1

1. Remove the cover by loosening the four cover screws.
2. Separate the adapter from the base by loosening the three recess screws on top of the base.

Installation on air actuators:

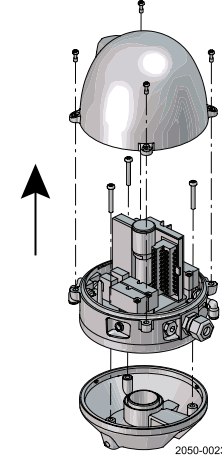

Step 2

1. Fit air fittings on actuator.
2. Position packing retainer in recess on actuator top.
3. Fit counter nut and indication pin (magnet) on actuator rod. Engage approx. $\frac{1}{4}$ thread. Tighten counter nut and indicator with two wrenches.

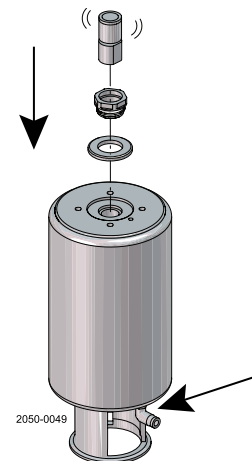

Step 3

1. Place the two O-rings in the grooves in the bottom of the adapter. Then place the adapter on the actuator top. The small O-ring must be positioned over the air hole on the actuator.
2. Fasten the adapter with the four 5/16" Allen screws.

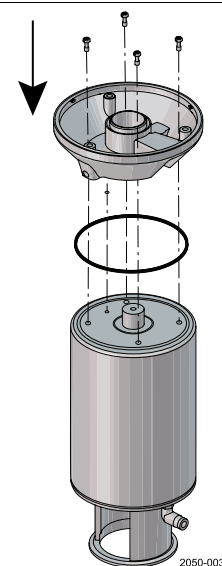

5 Installation

Step 4

Mount the base on the adapter in the necessary position (can be rotated 120° in both directions). Note that one of the screw towers on the adapter has a guide recess (see * on diagram).

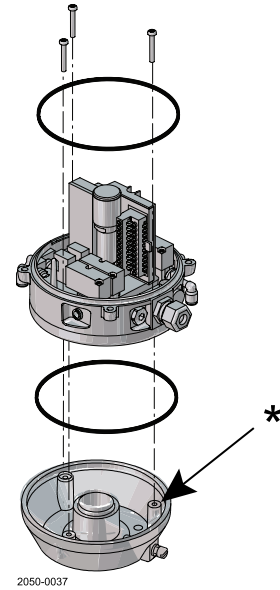

5.3 Air connections

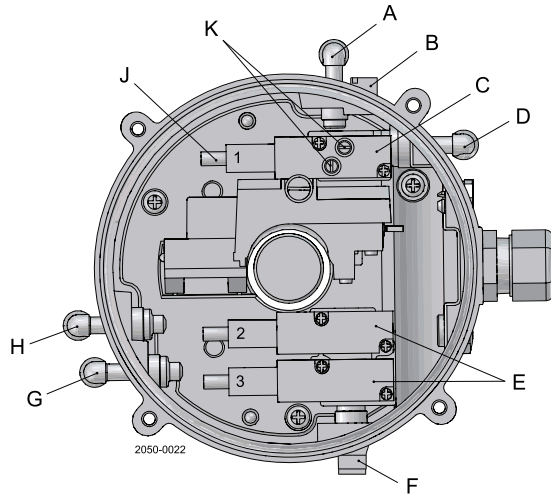

- A Air out 1A
- B Air exhaust
- C Solenoid 3/2 or 5/2
- D Air out 1B (5/2 port solenoid valve only)
- E Solenoid valves only 3/2
- F Air in
- G Air out 3
- H Air out 2
- J Manual hold override
- K Air restriction (throttle function) air inlet/outlet

5 Installation

5.4 Electrical connection, internal – Digital 24 VDC

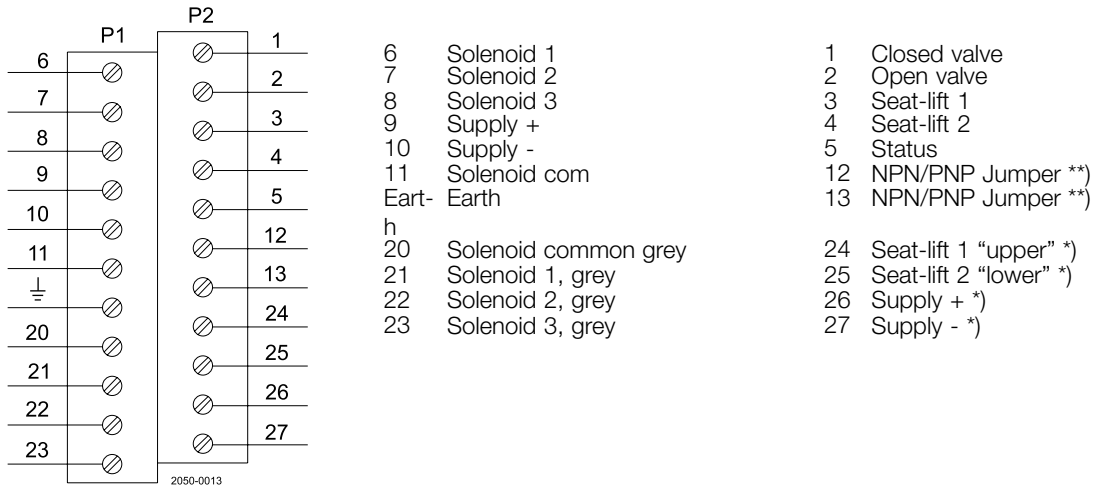

Table 1. Note!

*) If using external sensor, the sensor must be active/activated when performing a set-up routine of the control head.

Terminals 24, 25, 26 and 27 can be used for external seat lift sensors as well as for any digital input. Always use an external PNP sensor. Two external signals can be connected; these are associated with feedback signal 3 (seat-lift 1) and 4 (seat-lift 2). External sensor must always be a 8-30 VDC PNP 3 wire sensor. Connect (-) common on terminal 27 and (+) common on terminal 26. The signals from the external sensors are associated as follows: sensor signal on terminal 24 (seat-lift 1) associated with feedback 3 (seat-lift 1) and sensor signal on terminal 25 (seat-lift 2) associated with feedback 4 (seat-lift 2).

**) Jumper present = PNP. If changing the function a power recycle is necessary. The selection NPN/PNP is done by the jumper.

***) Internal connections: Terminals for connection for the solenoids mounted internally in the control head. The number of solenoids actually mounted in the control head could be 0 - 3. The signals are taken directly from the terminal row.

Note! Remember to isolate wires that are not in use.

5.5 Example of using common power supply

Install a jumper between terminal 10 + 11 to extend the sensor board supply to the solenoid valves.

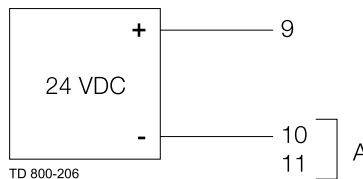

A: Jumper

5.6 Electrical connection, internal – AS-Interface

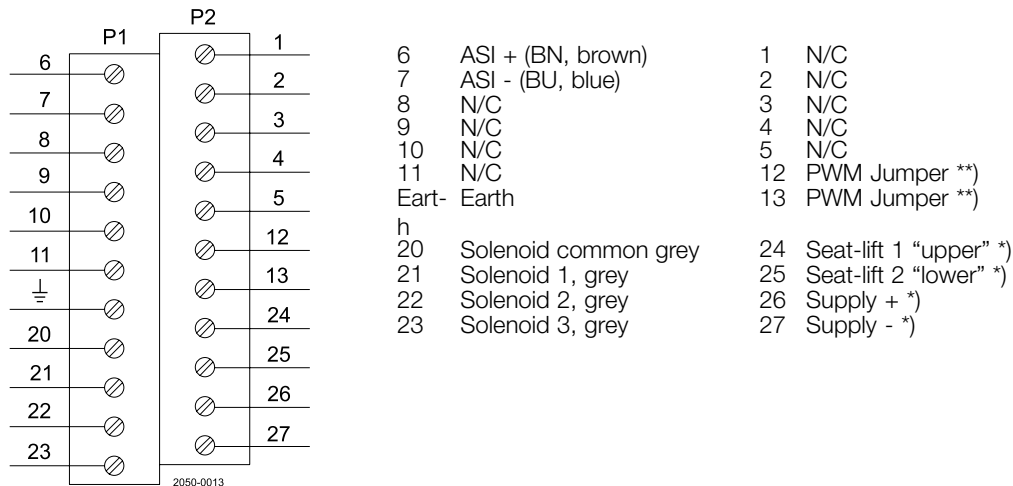

Table 2. Note!

*) If using external sensor, the sensor must be active/activated when performing a set-up routine of the control head.

Terminals 24, 25, 26 and 27 can be used for external seat lift sensors as well as for any digital input. Always use an external PNP sensor. Two external signals can be connected; these are associated with feedback signal 3 (seat lift 1) and 4 (seat lift 2). External sensor must always be a 8-30 VDC PNP 3 wire sensor. Connect (-) common on terminal 27 and (+) common on terminal 26. The signals from the external sensors are associated as follows: sensor signal on terminal 24 (seat lift 1) associated with feedback 3 (seat lift 1) and sensor signal on terminal 25 (seat lift 2) associated with feedback 4 (seat lift 2).

**) Jumper present = PWM. Reducing power consumption of solenoid valves.

***) Internal connections: Terminals for connection for the solenoids mounted internally in the control head. The number of solenoids actually mounted in the control head could be 0 - 3. The signals are taken directly from the terminal row.

Note! Remember to isolate wires that are not in use.

5 Installation

5.7 Electrical connection, internal – DeviceNet

Electrical connection

		DeviceNet 63 node			
		Sensor board			
		Terminal strip			
		P2			
		P1			
Not Connected	N/C	6	1	Power bus V- (Black)	} Bus cable
	N/C	7	2	CAN_L (Blue)	
	N/C	8	3	Drain (Bare)	
	N/C	9	4	CAN_H (White)	
	N/C	10	5	Power bus V+ (Red)	
Internal connections to solenoids 1-3 ***)	N/C	11	12	N/C	} Not connected
	N/C	11	13	N/C	
	Earth	Earth	24	Seat-lift 1 "upper"	} Incoming signals from external sensors *)
	Solenoid com.grey	20	25	Seat-lift 2 "lower"	
	Solenoid 1, grey	21	26	Supply +	} Supply to external sensors *)
	Solenoid 2, grey	22	27	Supply -	
	Solenoid 3, grey	23			

Table 3. Note!

*) If using external sensor, the sensor must be active/activated when performing a set-up routine of the control head.

Terminals 24, 25, 26 and 27 can be used for external seat lift sensors as well as for any digital input. Always use an external PNP sensor. Two external signals can be connected; these are associated with feedback signal 3 (seat-lift 1) and 4 (seat-lift 2). External sensor must always be a 8-30 VDC PNP 3 wire sensor. Connect (-) common on terminal 27 and (+) common on terminal 26. The signals from the external sensors are associated as follows: sensor signal on terminal 24 (seat-lift 1) associated with feedback 3 (seat-lift 1) and sensor signal on terminal 25 (seat-lift 2) associated with feedback 4 (seat-lift 2).

***) Internal connections: Terminals for connection for the solenoids mounted internally in the control head. The number of solenoids actually mounted in the control head could be 0 - 3. The signals are taken directly from the terminal row.

Note! Remember to isolate wires that are not in use.

6.1 ThinkTop setup- utilising local 'I' and 'II' keys

General

Default is: Step 2, tolerance is +/- 5 mm
Step 3-8, disabled

Timeout: A 60 sec. timeout is started as soon as any button(s) is released.
On timeout the setup is exited with no changes saved.

Flashing LED means no value set. Steady LED means value set as shown

[D] LED: Active during setup: Flashing in step 1
Steady in all other steps

Or during operations, error condition: Steady indicates hardware fault, indication pin out of range
Flashing indicates software fault

General commands in each step (except step 1):

- ⓘ Next step / skip step (In step 3-6 the program automatically moves to the next step when a position is stored)
- ⓘ_{5s} Clear / disable step (In step 2 this resets the unit to default)
(The command is accepted when all unlit LEDs flash briefly)

We recommend resetting the unit before performing a setup.

Symbols

- ⓘ Push local key "I"
- ⓘ Push local key "II"
- ⓘ_{5s} Hold key "II" for 5 sec

Simple representation of LED indication:

Yellow	B	<input type="checkbox"/>	
IR-Receiver		<input type="radio"/>	
Red	D	<input style="background-color: red;" type="checkbox"/>	Steady LED
Yellow	C	<input type="checkbox"/>	
Green	E	<input type="checkbox"/>	
Orange	F	<input type="checkbox"/>	
Yellow	A	<input style="background-color: yellow;" type="checkbox"/>	Flashing LED



6 Setup diagram

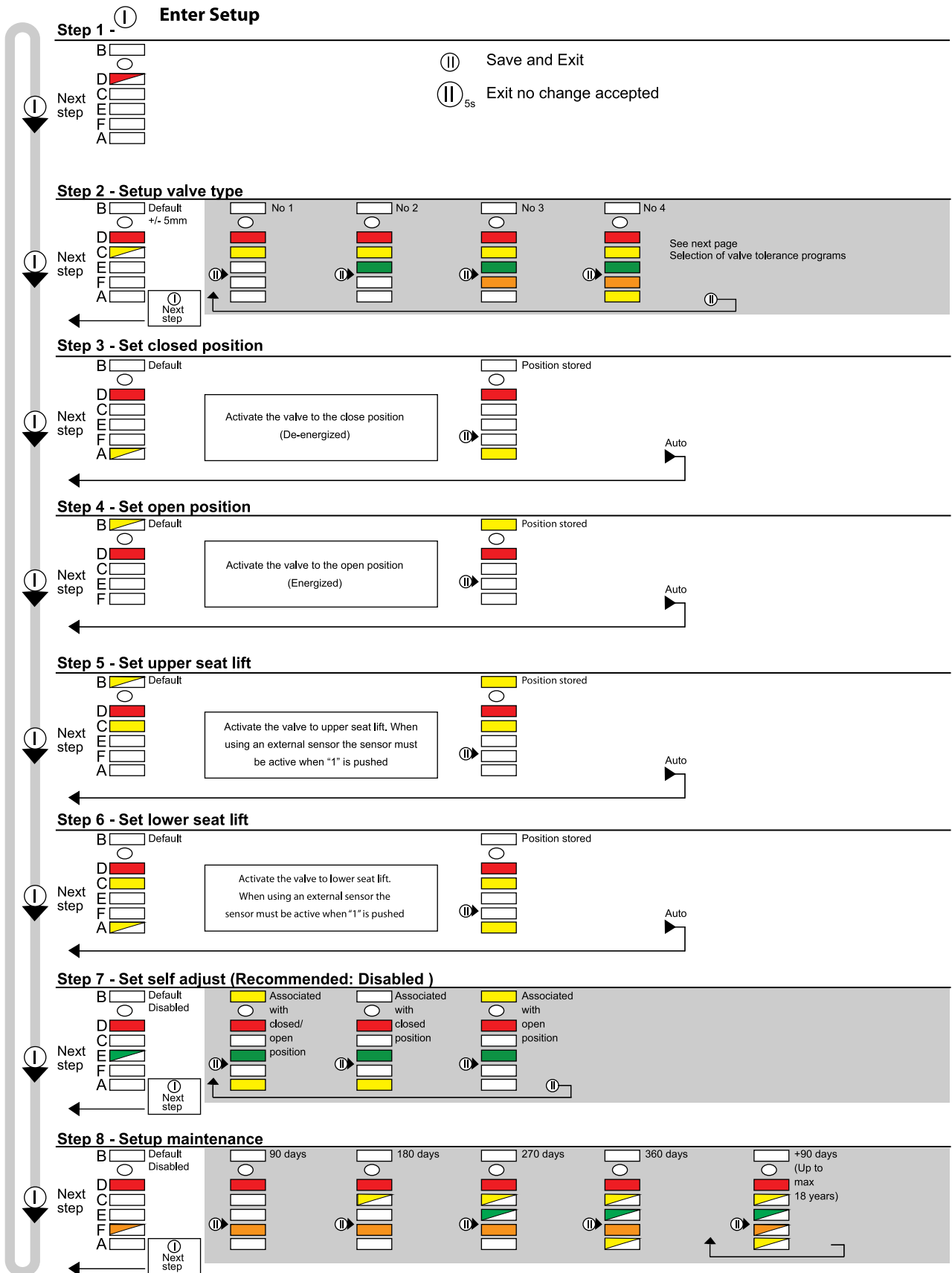

Tolerance programs				
Default	No. 1	No. 2	No. 3	No. 4
MH Koltek	(Used for self adjustment) ARC	LKB	Unique Mixproof	Unique SSV
SMP-EC	SRC	(LKLA-T)	SMP-SC Spillage free	Unique Mixproof PMO
Unique SSV NO shut off	Series 700		SRC-PV AMP	Unique Mixproof Curd Unique Mixproof CP3 Unique Mixproof LP Unique Mixproof HT Unique Mixproof VT Unique Mixproof 3A Unique 7000 ARC SRC SBV Series 700

6 Setup diagram

6.2 ThinkTop setup- utilising IR keypad

General

Flashing LED means no value set. Steady LED means value set as shown.

Default: Step 2, factory-set tolerance band +/- 5 mm
Step 3-8, disabled

D LED: Active during setup: Flashing in step 1
Steady in all other steps
Or during operations, error condition: Steady indicates hardware fault, indication pin out of range
Flashing indicates software fault

Timeout: A 60 sec. timeout is started as soon as any button/s is released
On timeout the setup is exited with no changes saved

IR Keypad: Remote distance 0-300 mm to ThinkTop®

Symbols

Push key on IR keypad with the same number

Simple representation of LED indication:

Yellow
IR-Receiver
Red
Yellow
Green
Orange
Yellow

B
D Steady LED
C
E
F
A Flashing LED



General commands in each step (except step 1):

- | | | |
|---------------------------------------|-----------------------|---|
| <input checked="" type="checkbox"/> 0 | Next step / skip step | (In step 3-6 the program automatically moves to the next step when a position is stored) |
| <input checked="" type="checkbox"/> 5 | Clear / disable step | (In step 2 this resets the unit and sets the step 2-8 to default)
(The command is accepted when all unit LEDs flash briefly) |

**We recommend resetting the unit before performing a setup.
Always check for correct signals after the setup.**

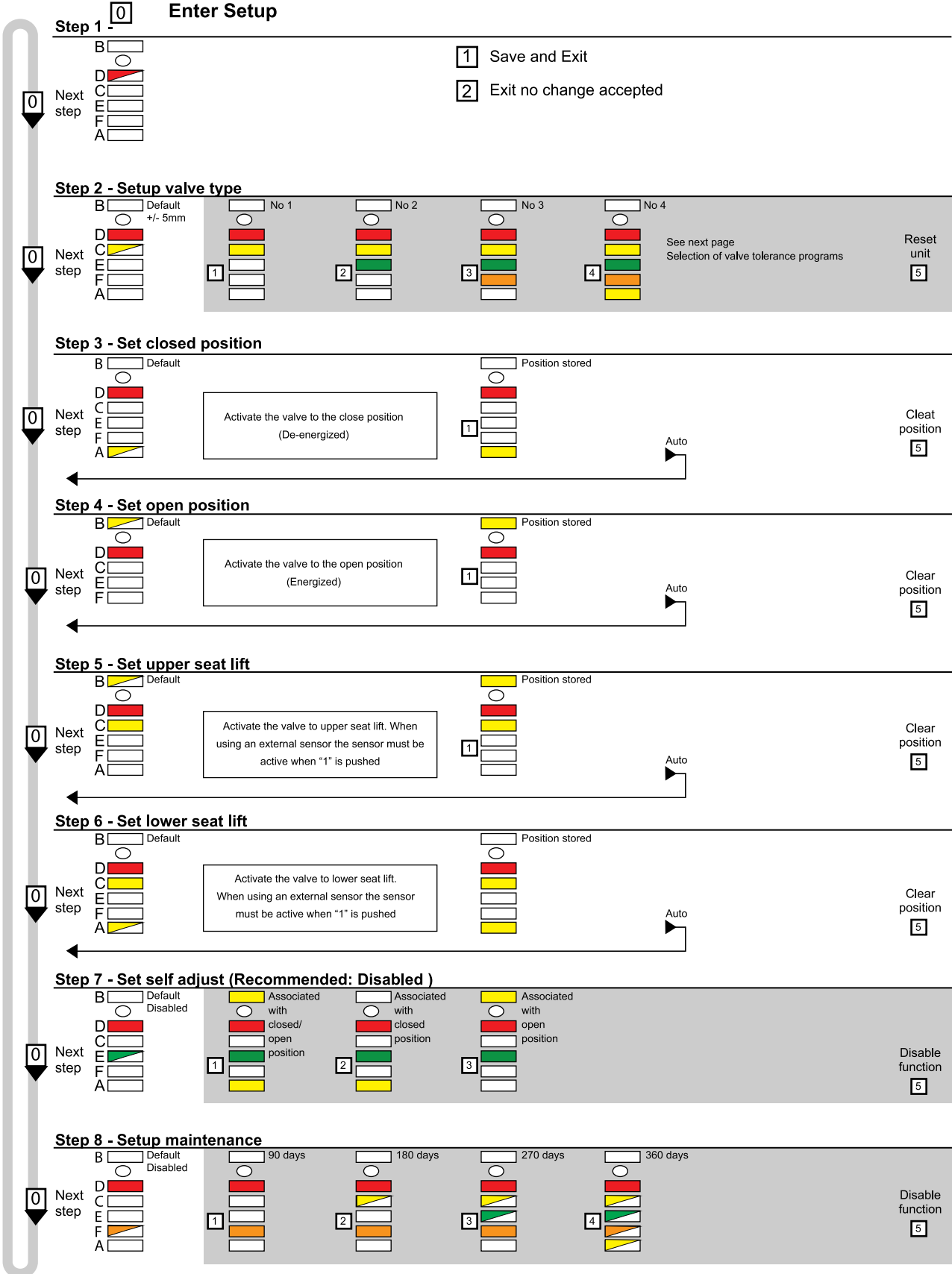

6 Setup diagram

6.3 ThinkTop quick setup guide

Valve: Unique SSV, SRC/ARC type NC (self-adjustment disabled)

Push:	I	- and wait until red LED flashes
Push:	I	
Hold:	II 5s	- hold for 5 sec (clear all stored parameters)
Push:	II	(red + yellow LED)
Push:	II	(red + yellow + green LED)
Push:	II	(red + yellow + green + orange LED)
Push:	II	(red + yellow + green + orange + yellow LED)
Push:	I	
Push:	II	- to approve valve down (closed)
	Activate	Valve opens
Push:	II	- to approve (open)
	Deactivate	Valve returns to closed
Push:	I	(no upper seat-lift)
Push:	I	(no lower seat-lift)
Push:	I	(no self-adjustment)
Push:	I	(no maintenance)
Push:	II	Red LED flashes (save & exit by push)
Setup complete		



Valve: SRC/ARC type NO (self-adjustment enabled)

Push:	I	- and wait until red LED flashes
Push:	I	
Hold:	II 5s	- hold for 5 sec (clear all stored parameters)
Push:	II	(red + yellow LED)
Push:	I	
	Activate	Valve closes
Push:	II	- to approve valve closed
	Deactivate	Valve opens
Push:	II	- to approve valve is open
Push:	I	(no upper seat-lift)
Push:	I	(no lower seat-lift)
Push:	II	= self-adjustment
Push:	I	
Push:	I	(no maintenance)
Push:	II	Red LED flashes (save & exit by push)
Setup complete		



Valve: LKB Valve (Butterfly) NC

Push:	I	- and wait until red LED flashes
Push:	I	
Hold:	II 5s	- hold for 5 sec
Push:	II	(red + yellow LED)
Push:	II	(red + yellow + green LED)
Push:	I	
Push:	II	- to approve valve closed (indication- stem up)
	Activate	LKB valve - open position (indication- stem down)
Push:	II	- to approve valve is open
	Deactivate	Valve returns to closed
Push:	I	(no upper seat-lift)
Push:	I	(no lower seat-lift)
Push:	I	(no self-adjustment)
Push:	I	(no maintenance)
Push:	II	Red LED flashes (save & exit by push)
Setup complete		



Valve: LKB Valve (Butterfly) NO

Push:		- and wait until red LED flashes
Push:		
Hold:	5s	- hold for 5 sec (clear all stored parameters)
Push:		(red + yellow LED)
Push:		(red + yellow + green LED)
Push:		
	Activate	- to close valve
Push:		- to approve valve closed
	Deactivate	LKB valve - open position
Push:		- to approve valve open
Push:		(no upper seat-lift)
Push:		(no lower seat-lift)
Push:		(no self-adjustment)
Push:		(no maintenance)
Push:		Red LED flashes (save & exit by push)

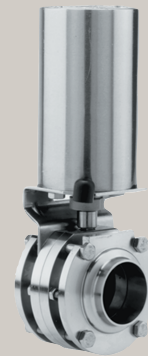

Setup complete

Valve: Unique mixproof Valve (with lower seat-lift, but without external sensor for upper seat detection)

Push:		- and wait until red LED flashes
Push:		
Hold:	5s	- hold for 5 sec (clear all stored parameters)
Push:		(red + yellow LED)
Push:		(red + yellow + green LED)
Push:		(red + yellow + green + orange LED)
Push:		
Push:		- to approve valve closed
	Activate	Valve opens
Push:		- to approve valve is open
	Deactivate	Valve returns to closed
Push:		(no upper seat-lift)
	Activate	Lower seat-lift active
Push:		- to approve
	Deactivate	Valve returns to closed
Push:		(no self-adjustment)
Push:		(no maintenance)
Push:		Red LED flashes (save & exit by push)







Setup complete

7 Fault finding

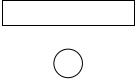
7.1 Fault finding and LEDs

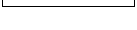
The information below explains the meaning of the LEDs' indications for fault finding in connection with the operation of the ThinkTop.

	<p>Red flashing:</p>	<p>Unit in setup mode or internal software fault. If internal software fault is present, re-programme unit.</p>
	<p>Red steady:</p>	<p>Unit in setup mode or internal hardware fault. If internal hardware fault is present, check magnet is in range and check correct wiring.</p>
	<p>1 Orange flashing:</p>	<p>Time for maintenance has expired. The unit has been self-adjusted into a maintenance alert condition. Valve maintenance is strongly recommended. After maintenance: Disabling of maintenance/self-adjustment function is required before setting new position, however, it is strongly recommended to perform an entirely new setup after valve maintenance.</p>
	<p>2 Orange steady,</p>	<p>The unit has been self-adjusted into a maintenance alarm condition and the feedback is lost (a minimum of seal left). Valve maintenance is required. After maintenance: Disabling of the self-adjustment function is required before setting new position, however, it is strongly recommended to perform an entirely new setup after valve maintenance.</p>
	<p>NOTE!</p>	<p>The maintenance indicator lights up and an open or closed light flashes..... = Note the following:</p> <ul style="list-style-type: none"> - Self-adjustment program is only valid for SRC/ARC valves; do not use the program for other valve types. - Use tolerance/valve type 1. - In conjunction with valve type change-over; 21, 22, 31 and 32, the open position must be defined as the upper sensor position (when the indication pin is in the highest position). - A loose top, indication pin or sensor system can also generate the alert/alarm condition. - Removing a ThinkTop with self-adjust activated, will immediately generate an alarm condition! If the ThinkTop has to be removed - not because of a valve maintenance issue - but for another reason and you wish to store the data already adjusted, disable the self-adjust function before removing the ThinkTop and enable it again once the ThinkTop is back on the actuator. - After valve maintenance it is necessary to disable the self-adjustment function before setting a new position, however, it is strongly recommended to perform an entirely new setup (disable all functions in step 2 valve type - and perform an entirely new setup).

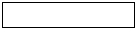
	<p>Yellow steady:</p>	<p>Position A (closed valve).</p>
---	-----------------------	-----------------------------------

Yellow B Yellow steady: Position B (open valve).



Yellow steady: Position C (Seat lift 1-2 or external sensors).



Yellow C



Green Green steady: Solenoid valves energised.

Note! LED lights have different functions during setup.

8 Maintenance

Read the instructions carefully.

Handle scrap correctly.

Always have spare X-rings to hand.

8.1 Dismantling ThinkTop

Step 1

1. Untighten the two Allen screws and remove the ThinkTop from the actuator
2. Pull out X-ring (19) and replace it

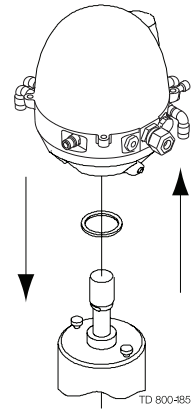

Step 2

1. Untighten the four screws
2. Remove ThinkTop cover
3. Remove X-ring (9) (grey)

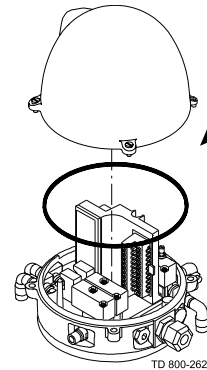

Step 3

1. Untighten screws
2. Remove solenoid valves (up to three) and replace them with new ones

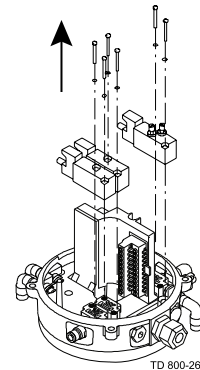

Step 4

1. To dismantle the adapter (the lower part of the ThinkTop) from base (the middle part), unscrew the three screws
2. Turn the lower part clockwise slightly and pull
3. Replace adapter if necessary
4. Remove the black X-ring

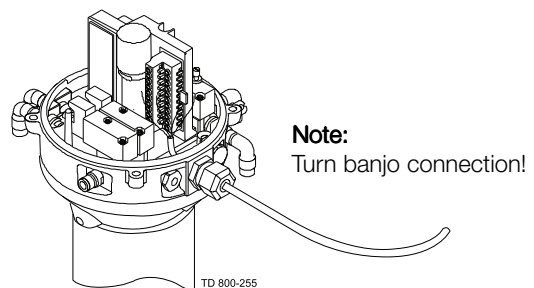

Read the instructions carefully.
 Handle scrap correctly.
 Always have spare X-rings to hand.

Step 5

To remove the sensor unit, untighten screw and pull out the sensor unit.

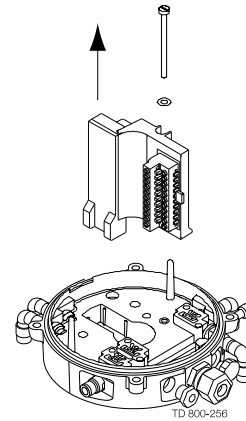

8.2 Assembly of ThinkTop

Step 1

Place sensor unit in base and tighten screw (torque: 1 Nm).

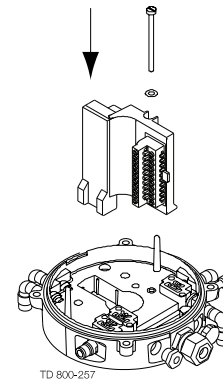

Step 2

1. Replace the black X-ring.
2. Assemble base with adapter by turning adapter slightly anticlockwise and tighten the four screws (1.9 Nm).

CAUTION!

Do NOT twist the X-ring in the groove!
 The X-ring is not square. The highest (h) part must be positioned as shown.

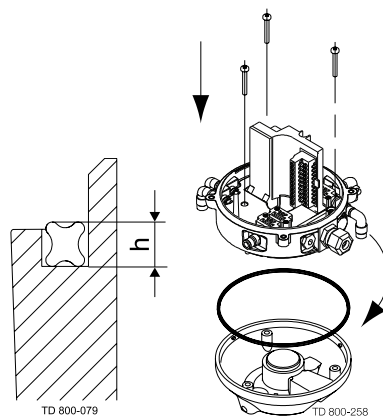

Note:
 Turn banjo connection!

8 Maintenance

Read the instructions carefully.

Handle scrap correctly.

Always have spare X-rings to hand.

Step 3

1. Replace solenoid valves (up to three) with new ones.
2. Tighten screws (0.2 Nm).

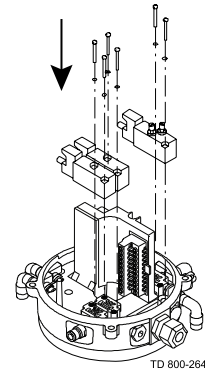

Step 4

1. Replace the grey X-ring.
2. Replace cover of ThinkTop and tighten the four screws (0.6 Nm).

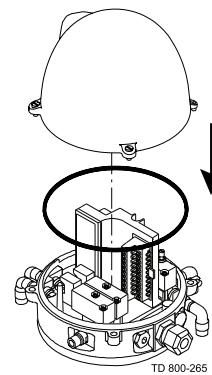

Step 5

1. Replace the black X-ring.
2. Mount ThinkTop on actuator.

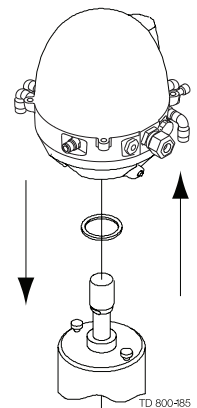

*Read the instructions carefully.
Handle scrap correctly.
Always have spare X-rings to hand.*

8.3 Dismantling and assembling Series 700 valves

Step 1

1. Remove the cover by loosening the four cover screws.
2. Separate the adapter from the base by loosening the three recess screws on top of the base.

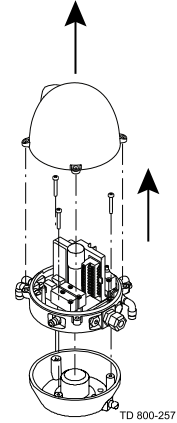

Step 2

1. Fit air fittings on actuator.
2. Position packing retainer in recess on actuator top.
3. Fit counter nut and indicator (magnet) on actuator rod. Engage approx. 1/4" thread. Tighten counter nut and indicator with two wrenches.

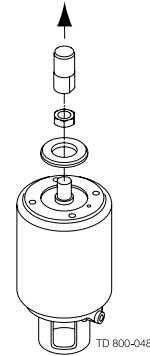

Step 3

1. Place the two O-rings in the grooves in the bottom of the adapter. Then place the adapter on the actuator top. The small O-ring must be positioned over the air hole on the actuator.
2. Fasten the adapter with the four 5/16" Allen screws.

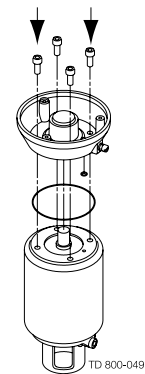

8 Maintenance

Read the instructions carefully.

Handle scrap correctly.

Always have spare X-rings to hand.

Step 4

1. Mount the base on the adapter in the necessary position (can be rotated 120° in both directions). Note that one of the screw towers on the adapter has a guide recess (see * on drawing).
2. Remove X-rings (9) (grey) and (16) (black).
3. Replace with new ones.

CAUTION! Do NOT twist the X-ring in the groove! The X-ring is not square; The highest (h) part must be positioned as shown

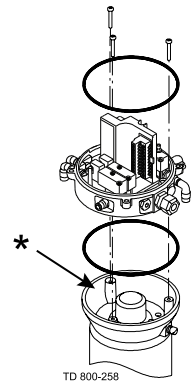
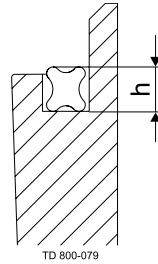

The items refer to the parts lists in the following sections

9.1 Diagrams for ThinkTop

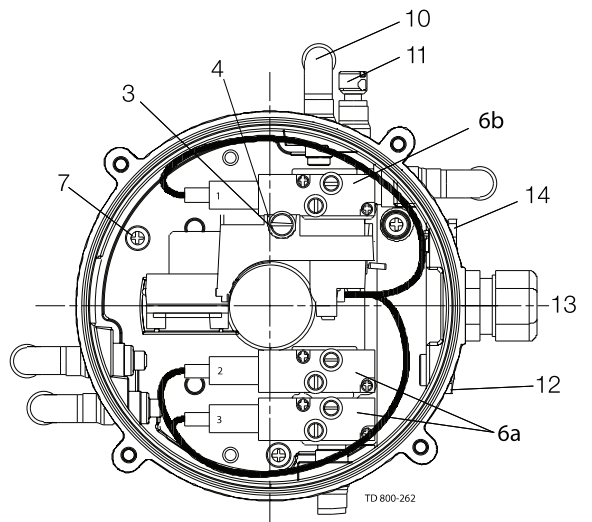
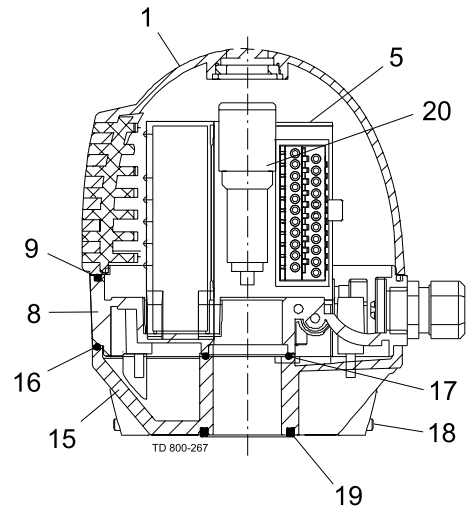
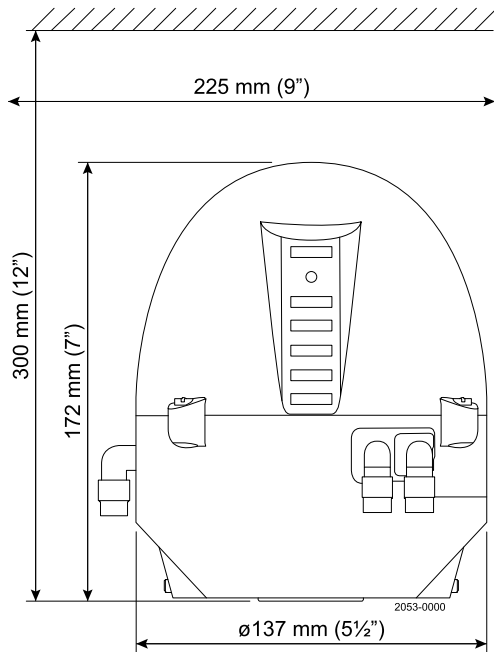

9 Parts list

The items refer to the parts lists in the following sections

9.2 ThinkTop

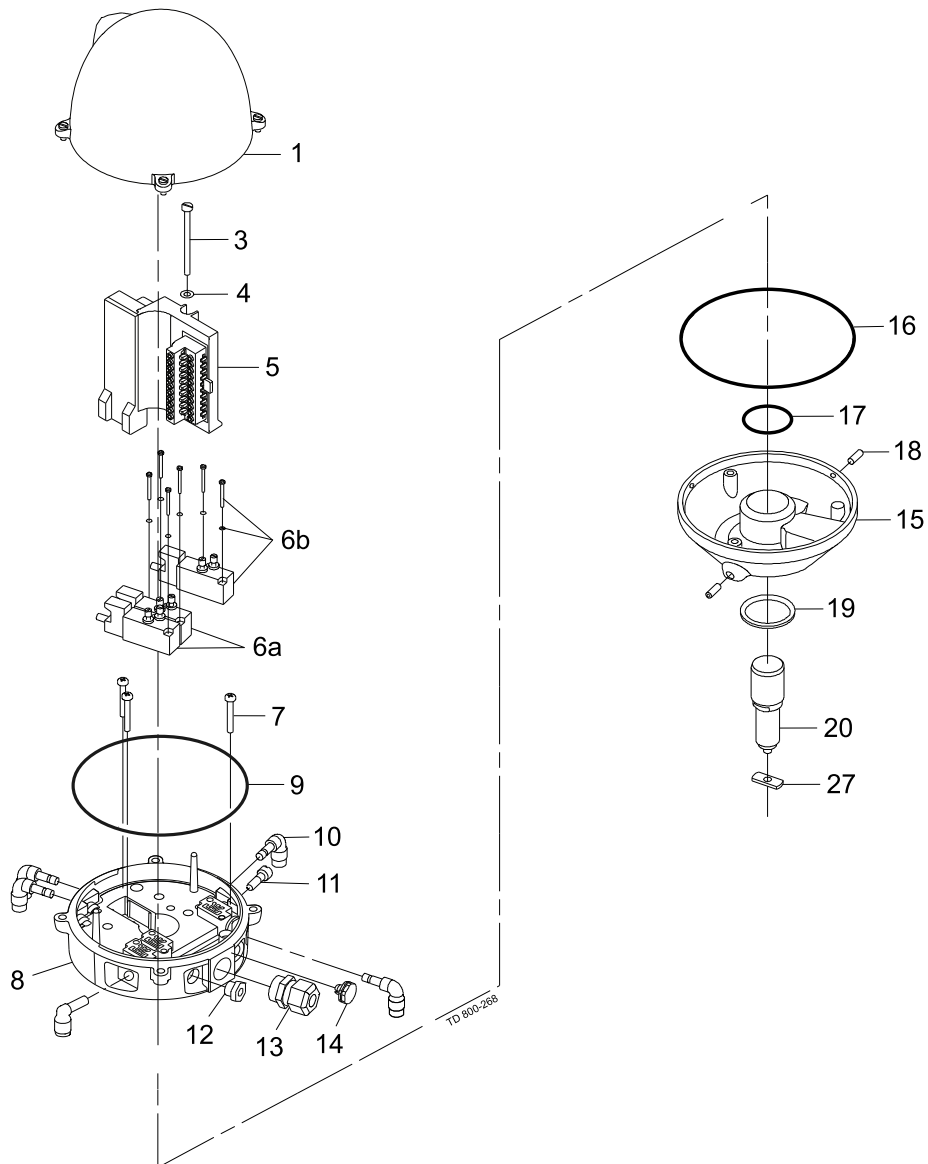

The items refer to the parts lists in the following sections

Parts list

Pos.	Qty	Denomination
1	1	Shell complete
3	1	Screw
4	1	Washer
5	1	Sensor board
6a	1-2	Solenoid valve (3/2)
6b	1	Solenoid valve (3/2 or 5/2)
7	3	PT screw
8	1	Base
9	1	Special X-ring, grey
10	2-5	Air fittings
11	1	Blow-off valve
12	1	Thread plug, PG7
13	1	Cable gland, PG11 (or optional M12 plug)
14	1	Gore vent
15	1	Adapter complete
16	1	Special X-ring, black
17	1	O-ring
18	2	Allen screw
19	1	Special X-ring
20	1	Indication pin
27	1	Threaded plate (accessory for the Think Top)

The items refer to the parts lists in the following sections

9.3 Diagrams for ThinkTop: Series 700

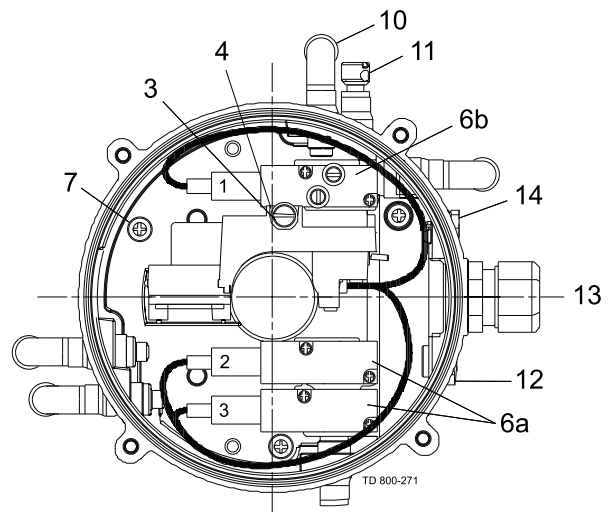
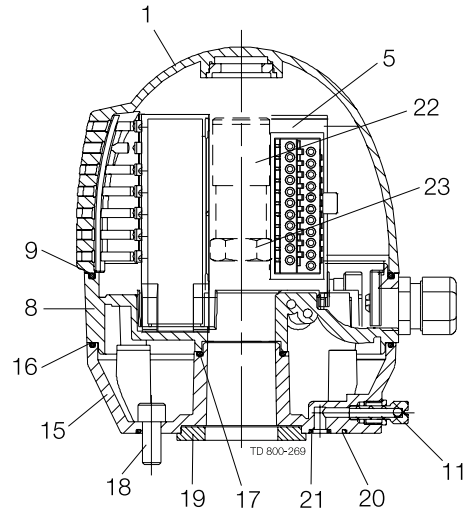
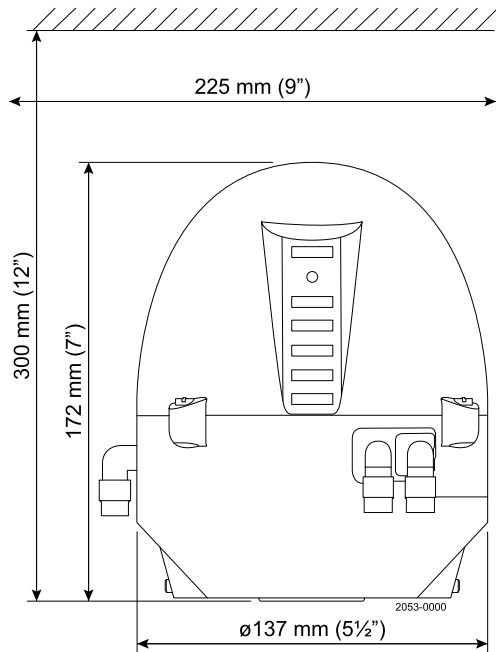

9 Parts list

The items refer to the parts lists in the following sections

9.4 ThinkTop: Series 700

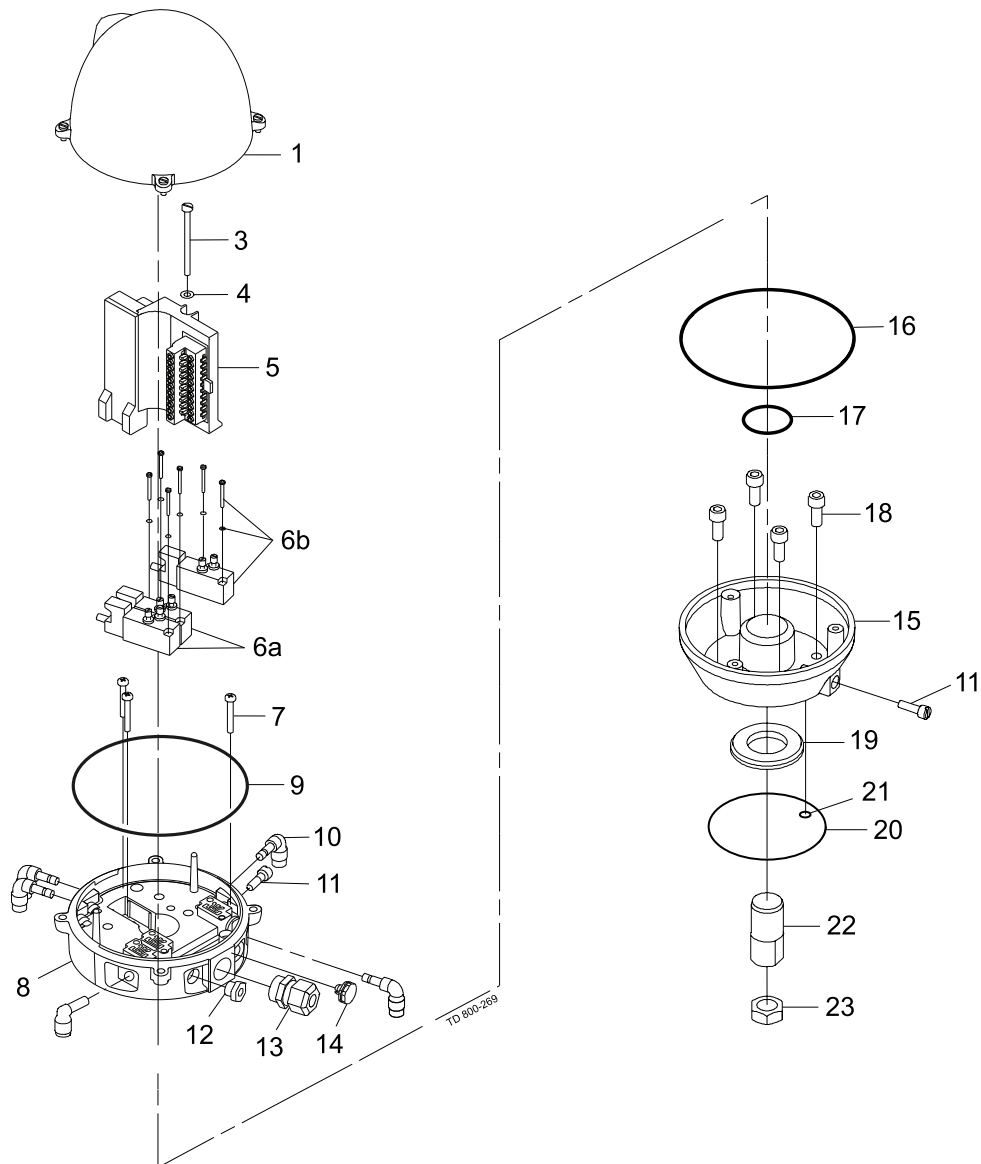

The items refer to the parts lists in the following sections

Parts list

Pos.	Qty	Denomination
1	1	Shell complete
3	1	Screw
4	1	Washer
5	1	Sensor board
6a	1-2	Solenoid valve (3/2)
6b	1	Solenoid valve (3/2 or 5(2))
7	3	PT screw
8	1	Base
9	1	Special X-ring, grey
10	2-5	Air fittings
11	2	Blow-off valve
12	1	Thread plug, PG7
13	1	Cable gland, PG11
14	1	Gore vent
15	1	Adapter complete
16	1	Special X-ring, black
17	1	O-ring
18	4	Screw
19	1	Retainer
20	1	O-ring
21	1	O-ring
22	1	Indicator pin
23	1	Nut

How to contact Alfa Laval

Contact details for all countries are continually updated on our website.

Please visit www.alfalaval.com to access the information directly.

© Alfa Laval Corporate AB

This document and its contents is owned by Alfa Laval Corporate AB and protected by laws governing intellectual property and thereto related rights. It is the responsibility of the user of this document to comply with all applicable intellectual property laws. Without limiting any rights related to this document, no part of this document may be copied, reproduced or transmitted in any form or by any means (electronic, mechanical, photocopying, recording, or otherwise), or for any purpose, without the expressed permission of Alfa Laval Corporate AB. Alfa Laval Corporate AB will enforce its rights related to this document to the fullest extent of the law, including the seeking of criminal prosecution.