

TOTETILTER™



TrueClean® | INSTALLATION / OPERATION / MAINTENANCE



Table of Contents

Introduction	3
Safety	4
At a Glance	5
Installation — ToteTilter	6
Installation — Fixed ToteTilter	7
Operation	8
Maintenance — Replacing Airlines	9
Maintenance — Replacing Actuators	10
Maintenance — Grease Fittings	11
Parts List	12
Troubleshooting	13
Customer Notes	14
Warranty	15

Introduction

ABOUT

Thank you for purchasing a TrueClean® product.

This manual contains installation, operation, and maintenance instructions for the TrueClean ToteTilter™. The ToteTilter is designed for minimal routine maintenance, but care and attention should be given to the instructions provided in this manual.

All ToteTilters are available with an optional ToteStand™ that can provide additional functionality. Refer to the ToteStand service manual for more information.

Do not remove any labeling on any TrueClean product. Immediately replace any label that is missing.

If, at any point, you have questions or concerns regarding your ToteTilter, please call 800.654.5635 or 417.831.1411.

Safety

IMPORTANT SAFETY INFORMATION

Read this manual before installing, operating, and maintaining this equipment. Failure to read the manual can result in personal injury and/or equipment damage.

Do not attempt to remove and/or modify any TrueClean products or programming. Doing so can create unsafe conditions for the operator(s) and/or surrounding persons. Any change to TrueClean products or programming will void any and all warranties.

Do not place any TrueClean product in an application where general product service ratings are exceeded. Doing so puts the operator(s) and/or surrounding persons at risk of personal injury and/or result in equipment damage.

The words **DANGER**, **WARNING**, and **CAUTION** and their meanings, as used within these instructions, are listed below:



DANGER

Indicates an imminently hazardous situation, which if not avoided, has a high likelihood of resulting in death or serious injury. This symbol is used in only the most extreme at-risk cases and warrants immediate action.



WARNING

Indicates a potentially hazardous situation, which if not avoided, could result in death or serious injury. This symbol is used for moderately at-risk cases and warrants immediate action.

CAUTION

Indicates a potentially hazardous situation, which if not avoided, may result in minor or moderate injury. This symbol may also be used to alert against an unsafe operating or maintenance practice.

If, at any point during operation a Danger, Warning, or Caution indication is present, the operator should immediately take steps to resolve the problem and/or seek assistance from a supervisor.

Do not remove any labeling on any TrueClean product. Immediately replace any label that is missing.

DISCLAIMER OF LIABILITY

TrueClean does not assume responsibility and expressly disclaims liability for loss, damage, or expenses that arise in any way from the installation, operation, use, or maintenance performed in accordance with this manual. TrueClean assumes no responsibility for any infringement of patents or other rights of third parties that may result from use of the module. No license is granted by implication or otherwise under any patent or patent rights.

TrueClean reserves the right to make changes to the product, specifications, or this manual without prior notice.

At a Glance

TOTETILTER™

- 1 Tote frame, upper section
- 2 Tote frame, lower section
- 3 Mechanical stop
- 4 Actuator bellows
- 5 Air pressure regulator
- 6 Hand Valve (included)
- 7 Foot Valve (optional)

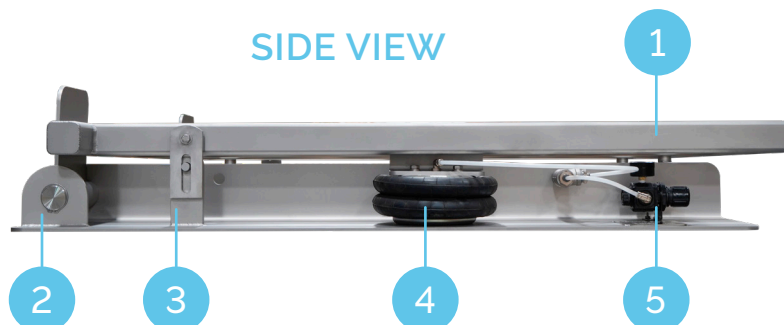
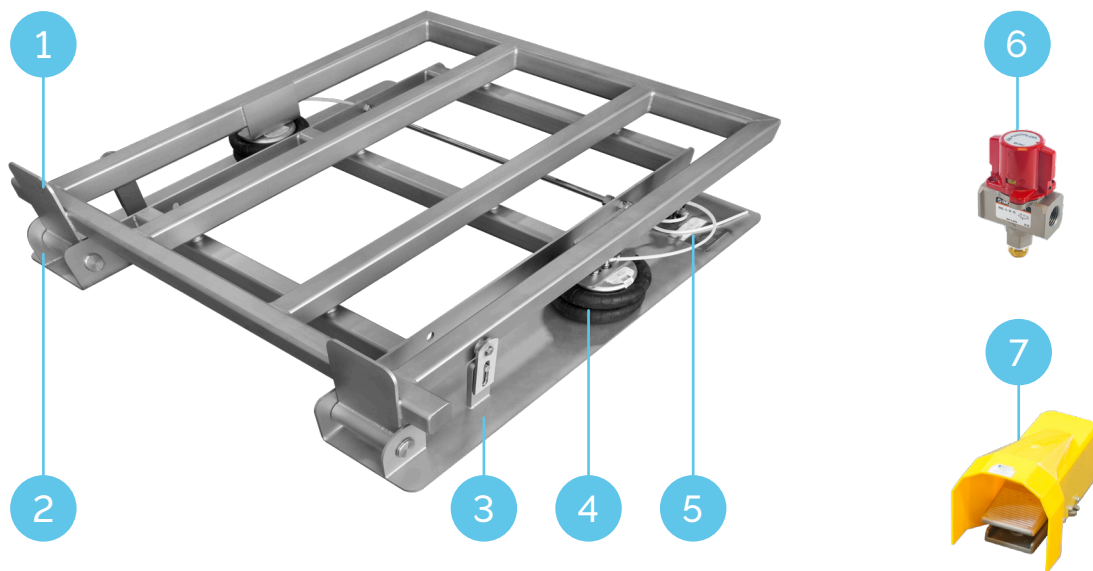

Installation

This manual provides the most common or general installation instructions. If there is a need to deviate from the methods described below, please contact us for additional technical support.

TECHNICAL DATA:

Tilt Options: 5° or 10°

Controls: Hand valve (standard), Foot valve (optional)

Maximum load: 5000 lb

Maximum lift: 1600 lb

Maximum inlet pressure: 150 psig

Maximum set pressure: 30 psig (5° model) or 15 psig (10° model)

INSTALLING TOTETILTER:

1. Place the ToteTilter on a level surface — leaving sufficient room for forklift travel.
Note: Shims, grout, etc., can be used to level the ToteTilter.
2. The ToteTilter should be set into place using a forklift or other equipment-moving machine.
3. Connect the plant-provided airline to the ¼" NPT connection on the regulator (150 psig maximum inlet pressure).

Note: The pressure regulator should be verified at the stated pressure for the specific unit. This information can be found on the equipment tag.

CAUTION

Pneumatic connections should be made in accordance with local, state, and federal codes and standards.

CAUTION

Care should be taken when loading and unloading the ToteTilter to prevent the unit from sliding out.



WARNING

Operating the ToteTilter with pressure regulator in excess of 30 psi can result in unsafe conditions.



WARNING



Never attempt to move the ToteTilter or ToteStand with a tote, intermediate bulk container, or other container placed on top.

Installation

INSTALLING FIXED TOTETILTER:

1. Place the ToteTilter on a level surface — leaving sufficient room for forklift travel.
Note: Shims, grout, etc., can be used to level the ToteTilter.
2. The ToteTilter should be set into place using a forklift or other equipment-moving machine
3. Mounting holes may have been requested at the time of purchase or may be drilled by the owner in the available space of the ToteTilter's stationary base.
 - Care should be taken when drilling holes in the stationary base to avoid damaging additional components.
 - The owner is responsible for determining the most appropriate fastener to be used when mounting a ToteTilter.
 - At no point should holes be drilled or modifications made to the articulating frame of the ToteTilter as it is a structural member. Altering the frame in any way can result in personal injury or death.
 - It is not necessary to affix the ToteTilter to a permanent structure, assuming it is operated properly.
4. Connect the plant-provided airline to the ¼" NPT connection on the regulator (150 psig maximum inlet pressure).

Note: The pressure regulator should be verified at the stated pressure for the specific unit. This information can be found on the equipment tag.

CAUTION	Pneumatic connections should be made in accordance with local, state, and federal codes and standards.
CAUTION	Care should be taken when loading and unloading the ToteTilter to prevent the unit from sliding out.
 WARNING	Operating the ToteTilter with pressure regulator in excess of 30 psi can result in unsafe conditions.
 WARNING	Never attempt to move the ToteTilter or ToteStand with a tote, intermediate bulk container, or other container placed on top.

Operation

CAUTION

Operators should refrain from making contact or interfering with a ToteTilter while it is raising or lowering as pinch points may exist.

CAUTION

Operators should not attempt to load or unload a ToteTilter while it is raising or fully raised.

RAISING SEQUENCE:

1. Ensure the plant airline is connected to the pressure regulator
2. Verify the pressure regulator is set for the recommended pressure, as indicated on the equipment tag.
3. Actuate the hand valve (or optional foot valve) to allow compressed air to flow and begin filling sequence. A fully loaded tote may prevent it from tipping immediately, but as the tote weight decreases during unloading, the ToteTilter will gradually begin to raise — stopping at its maximum angle.

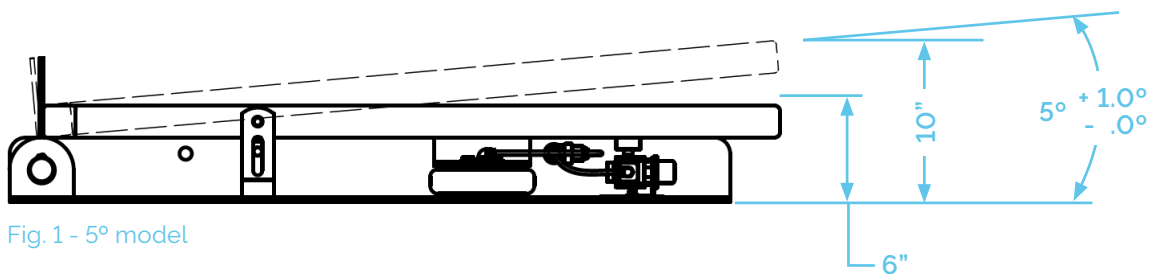

Fig. 1 - 5° model

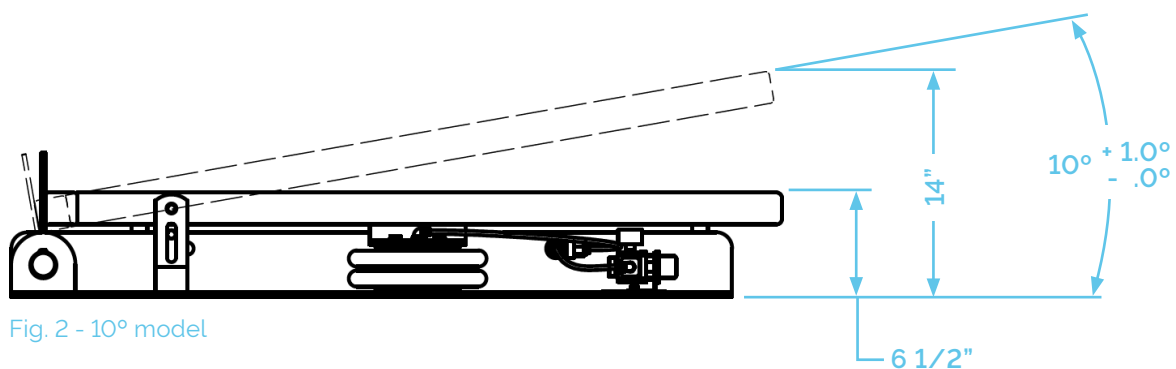

Fig. 2 - 10° model

LOWERING SEQUENCE:

1. Actuate the hand valve (or optional foot valve) again to begin the lowering sequence. With an empty tote, it may not be immediately obvious that the ToteTilter is releasing; however, you should begin to see the frame lowering within a few seconds.

Maintenance

General cleanliness will extend the life of the ToteTilter and its mechanical components. Where possible, the area should be kept free of spills and loose debris.



WARNING

Before maintenance begins, remove the inbound air supply from the pressure regulator. The ToteTilter should be in the 0° tilt position prior to maintenance.

MONTHLY CHECKLIST:

- Check airlines for cracks and leaks. (See Fig. 2)
- Check actuators for cracks, leaks, or signs of dry rot.
- Check for loose thread connections.
- Grease pivot points.

If any issues are found during the monthly check, cease use of the ToteTilter until they are resolved.

REPLACING AIRLINES:

1. Confirm that the ToteTilter is in the 0° tilt position, then disconnect the inbound airline at the pressure regulator.
2. Remove a leaking airline by pressing the outer ring of the ¼" pneumatic fitting and pulling the airline outward.
3. Repeat the same procedure for the other end of the airline.
4. Use cracked or leaking airline as a guide for the length of the new airline.
5. Trim new section of airline to the appropriate length.
6. Install airlines by pressing each end into ¼" pneumatic fittings.

Note: Give each end a slight pull to ensure the airlines are secured in place.

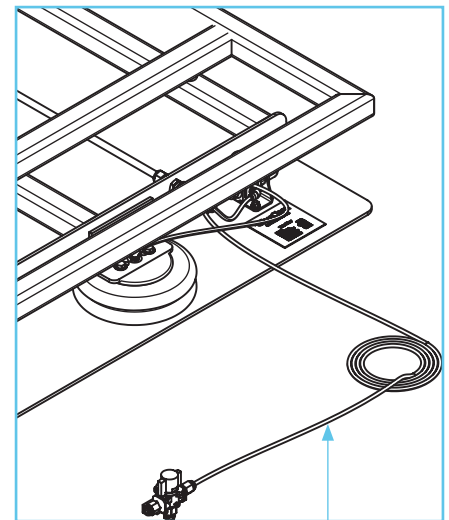

Fig. 3 - Poly Tube Airline



Fig. 4 - General representation of components

Maintenance

REPLACING ACTUATORS:

If one actuator needs to be replaced, it is recommended to replace the other — even if it is not leaking.

1. Confirm that the ToteTilter is in the 0° tilt position, then disconnect the inbound airline at the pressure regulator.
2. Remove the pneumatic fitting from the actuator, and confirm that it can be reused.
3. Loosen and remove retaining bolts. Once the retaining bolts are free, remove the actuator.

Note: Keep the retaining bolts — as the new actuators are not shipped with this hardware.

- 3/8" 16 UNC thread
 - Actuator bolt hole depth is 5/8"
4. Place the new actuator where the previous actuator was located.
 5. Install and tighten using the retaining bolts from step 3.
 - 3/8" 16 UNC thread
 - Actuator bolt hole depth is 5/8"
 - Tightening torque on the blind nut is 15-20 ft.-lbs (See Fig. 1)
 6. Install the pneumatic fitting on the new actuator.
 - Use a small amount of Teflon or similar sealing tape on threads.
 - Use caution to avoid cross-threading the pneumatic fitting.
 7. Connect the airline to the pneumatic fitting on the newly installed actuator.

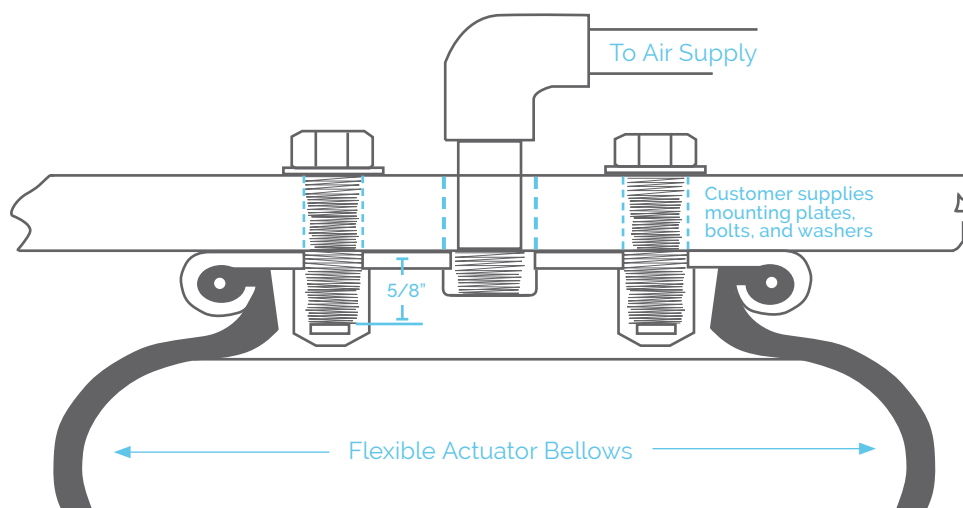

Fig. 5 - Cutaway of actuator

Maintenance

GREASE FITTINGS:

General-purpose bearing grease should be used, as approved by the facility manager, or in accordance with established manufacturing procedures.

1. Before applying new grease, wipe as much foreign debris off of the dynamic hinges as possible.
2. Apply generous amount of facility-approved bearing grease to each of the dynamic hinges.

Parts List

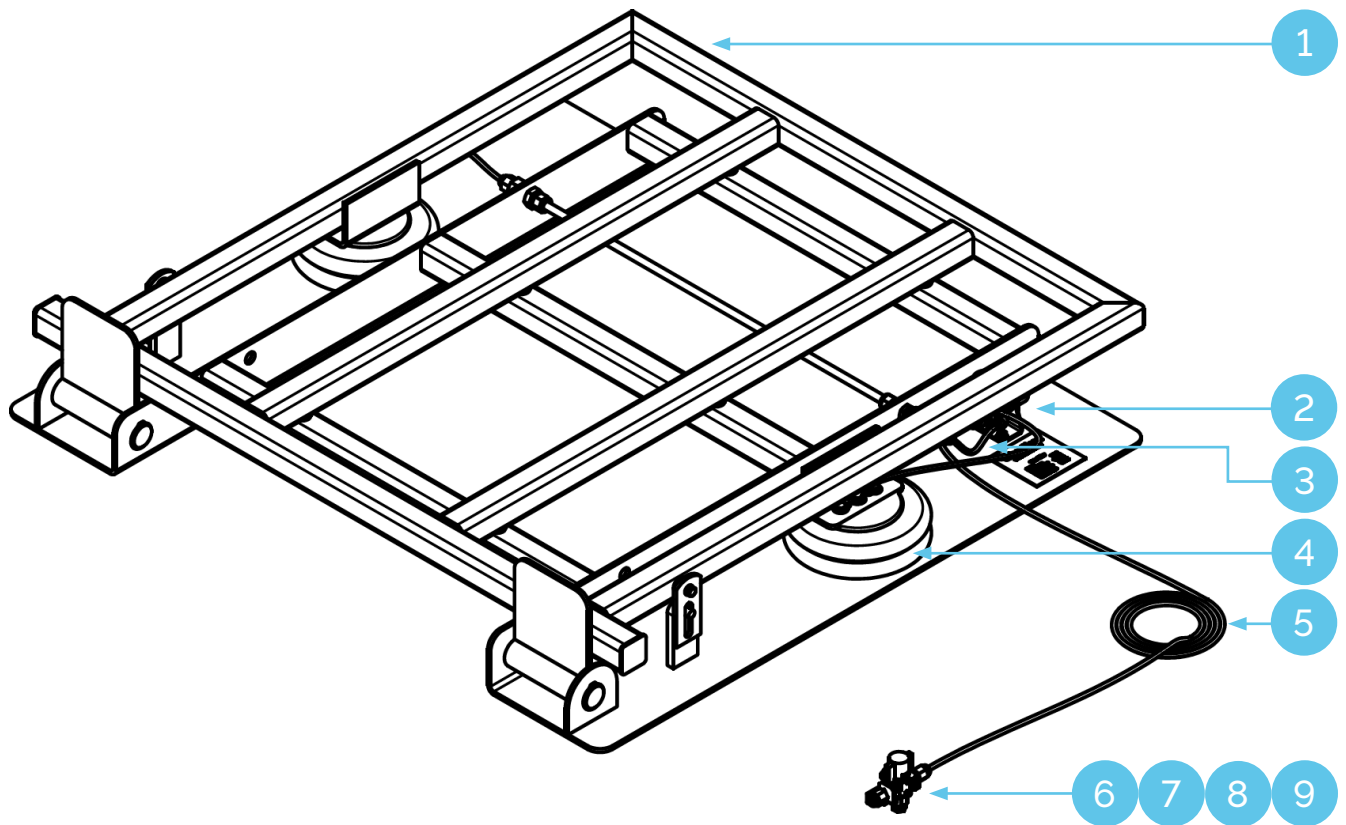

TOTETILTER PARTS LIST

ITEM	QTY	PART NUMBER	DESCRIPTION
1	1	5° MODEL: TTT-05-304A 10° MODEL: TTT-10-304A	FRAME STRUCTURE
2	1	R72G-2AK-RFG	COMPRESSED AIR REGULATOR
3	5	CS00964	1/4" COMPRESSED AIR INLET
4	2	5° MODEL: W01-358-7731 10° MODEL: W01-358-7325	FLEXIBLE ACTUATOR
5	1	41-6	AIRLINE FOR ACTUATOR
6	2	CS00409	1/4" MNPT CONNECTOR
7	1	VHS30-N02B-Z	0.25" RELIEF VALVE
8	1	VHS30PW-180AS	MOUNTING BRACKET
9	1	CS00978	BREATHER VENT

Troubleshooting

Q: What should I do when the TrueClean ToteTilter system fails to lift?

A: Try the following solutions:

1. Verify incoming plant air pressure to the unit is greater than 30 PSIG, and less than the maximum 150 PSIG.
2. Verify the pressure regulator is at the stated pressure for the specific unit. This information can be found on the equipment tag and is generally 15-30 PSIG.
3. Check for air leaks at connection points, air lines, lifting air bags, air shutoff valve, hand valve, and/or (optional) foot valve.
4. Check grease fittings and pivot points on the frame for binding.

Note: The system is not designed to lift a full tote. The system may remain flat with a full tote even when activated. The system is designed to tilt once the product level in the tote is reduced to a sufficient level for the actuators to overcome the product weight, thus enabling the remaining product to gravity drain from the tote.

Q: What should I do when the TrueClean ToteTilter actuators or airlines are damaged or leaking air?

A: Try the following solutions:

1. Verify the airline or actuator is damaged and not the result of a loose connection. If an airline or actuator needs replaced, please refer to the maintenance section of this manual to replace the faulty airline or actuator.

Warranty

- A. GENERAL PROVISIONS: Central States Industrial Equipment & Service Inc. (the "Company") warrants exclusively to the original purchaser (the "Customer") that equipment or parts thereof manufactured and sold by the Company will be free from defects in material and workmanship only, under normal use and service, for a period of one (1) year from the original shipment date. The Company shall not be liable for any loss of revenue or profit, loss by reason of plant shutdown, non-operation or increased cost of operation, loss of products or materials, or other special or consequential loss or damages resulting from any such warranted defects. This warranty will not apply to any equipment or parts which has been subjected to accident, alteration, abuse, or misuse. This warranty is in lieu of all other warranties. All other warranties, both express or implied (including, but not limited to, the implied warranties of merchantability and fitness for a particular purpose) warranties are hereby excluded and waived. The Company's only obligation and liability shall be to fulfill the warranty specifically stated herein. The Company will neither assume nor authorize any other person to assume for it any other obligation or liability in connection with the equipment or parts. In the event of a claim under this warranty, the Company's sole and exclusive liability for any warranted equipment or parts shall be, at the Company's option, limited to the following (a) the purchase price of the equipment or parts that are defective, (b) replacement of the defective equipment or parts or (c) repair of the defective equipment or parts.
- B. RETURN OF PARTS OR EQUIPMENT TO COMPANY PLANT: In the event the Company elects to inspect the alleged defective equipment or parts for possible repair, Company will notify Customer in writing, and the equipment or parts must be returned with transportation cost prepaid by the Customer. In the event the Company's inspection confirms defective equipment or parts covered by this warranty, the Company shall have the option to select any of the remedies described in Section A above. No transportation for returned or replaced items will be paid by the Company unless written approval for transportation charges is given by the Company.
- C. COMPONENTS NOT MANUFACTURED BY THE COMPANY: Components not manufactured by the Company, but furnished as part of its equipment (for example: valves, controls, gauges, electrical switches or instruments, etc.) will be warranted by the Company only to the extent of the component manufacturer's warranty.
- D. REPAIR OF EQUIPMENT INSTALLED IN THE CONTINENTAL UNITED STATES: In the event the Company elects to repair a covered item and it is, in the judgement of the Company, impractical to return the equipment or parts for repairs, the Company may arrange for the repairs to be made by its personnel or, at its option, sublet such repairs to a qualified company. The Customer will be expected to cooperate by making the equipment or parts available and accessible when the work is scheduled and is expected to provide the necessary utilities. If local labor conditions prohibit such work being done by Company personnel under the conditions and at the rates payable by its contracts with its employees, the Company obligation shall be limited to supervision of the work, replacement of defective parts, and labor costs in an amount equal to the amount which would be payable for a reasonable number of hours required to make the repairs at the rates payable under the terms of Company contracts with its employees. In such event, all labor costs shall be paid by the Customer and the Company will reimburse the Customer to the extent set forth above.
- E. REPAIR OF EQUIPMENT INSTALLED OUTSIDE THE CONTINENTAL UNITED STATES: In the event the Company elects to repair a covered item for a Customer located outside the continental United States and it is, in the judgement of the Company, impractical to return the equipment for repairs, the Company shall have the additional options (in addition to the other options described herein) of either sending a service representative to repair (or supervise the repairs) or paying Customer a reasonable amount to allow the Customer to have the repairs made locally; provided, that in such situation, Company shall have no obligation to repair or replace equipment or parts that are repaired on by third party contractors selected by Customer.



CSIDESIGNS.COM | +1.417.831.1411 | SALES@CSIDESIGNS.COM
SPRINGFIELD, MO | GRAND PRAIRIE, TX | DURHAM, NC | FRESNO, CA

