

# Ampco Centrifugal Pumps

## DATA SHEET

MODEL LD-RO1 1 1/2 X 1 1/2  
MODEL LD-RO2 1 1/2 X 1 1/2

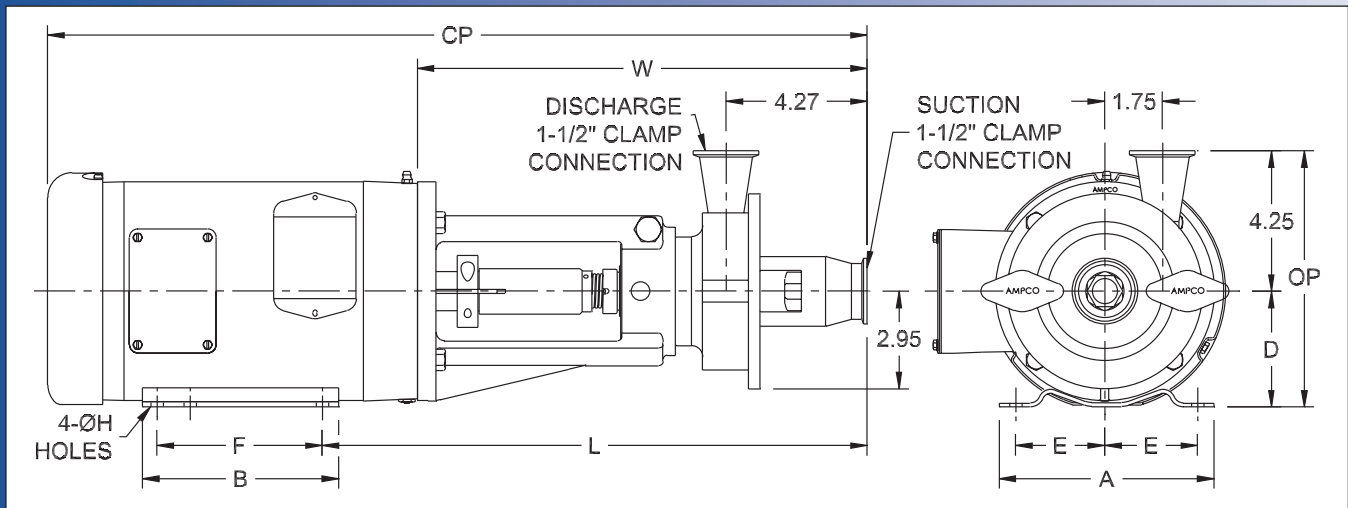
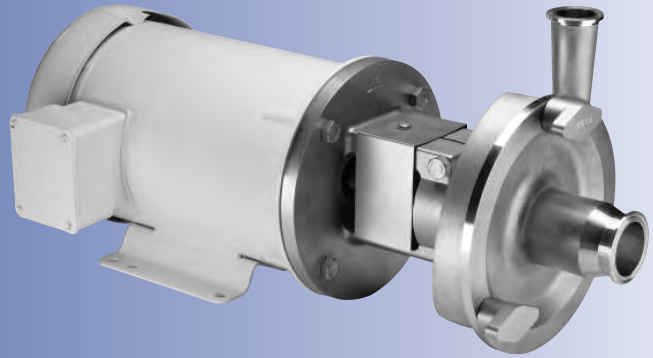

TEFC MOTOR			DIMENSIONS IN INCHES (For Reference Only)										APPROX WEIGHT (LBS)
HP	RPM	FRAME	A (typ)	B (typ)	D	E	F	ØH	L	W	CP	OP	
1	1750	143TC	6-1/2	6	3-1/2	2-3/4	4	11/32	16.31	13.54	24.62	7.75	68
1-1/2	3500	143TC	6-1/2	6	3-1/2	2-3/4	4	11/32	16.31	13.54	24.62	7.75	69
2	3500	145TC	6-1/2	6	3-1/2	2-3/4	5	11/32	16.31	13.54	24.62	7.75	76

## MATERIAL SPECIFICATIONS

PART NAME	STAINLESS STEEL
Casing, Cover & Impeller	316L Stainless
Stub Shaft	316L Stainless
Adapter	304 Stainless



**CSI**  
417.831.1411  
csidesigns.com



MODEL LD-R01 1 1/2 X 1 1/2  
 MODEL LD-R02 1 1/2 X 1 1/2

# Ampco Centrifugal Pumps

Curves show approximate characteristics based on clear 68° water. Rated point is guaranteed.

LD-Series pumps have standard stainless steel adapters and silicon carbide vs. carbon internal seals and carbon vs. ceramic external seals.

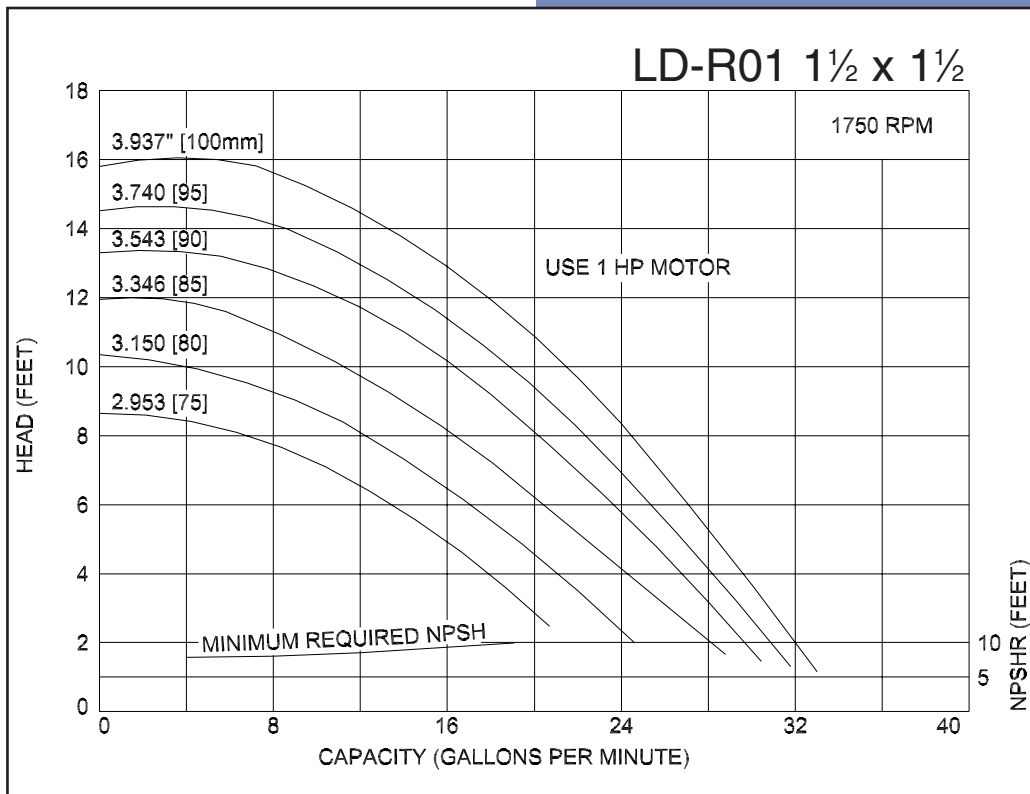
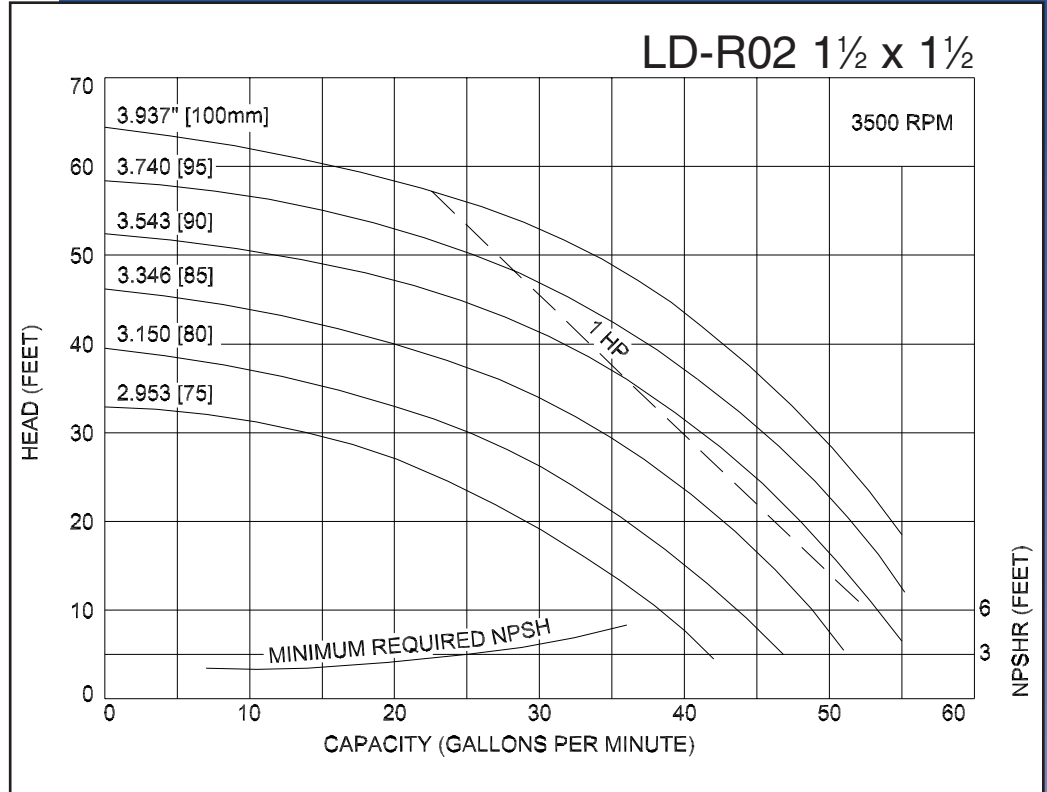

LD pumps are in conformance with 3A sanitary standards for centrifugal and positive rotary pumps for milk and milk products, Number 02-09.

LD-Series pumps have a standard 32RA (150 grit) finish, on all product contact surfaces.

**Ampco  
Pumps  
Company**



**CSI**  
417.831.1411  
csidesigns.com

# Ampco Centrifugal Pumps

## DATA SHEET

MODEL LD-R11 2X1 1/2  
MODEL LD-R12 2X1 1/2

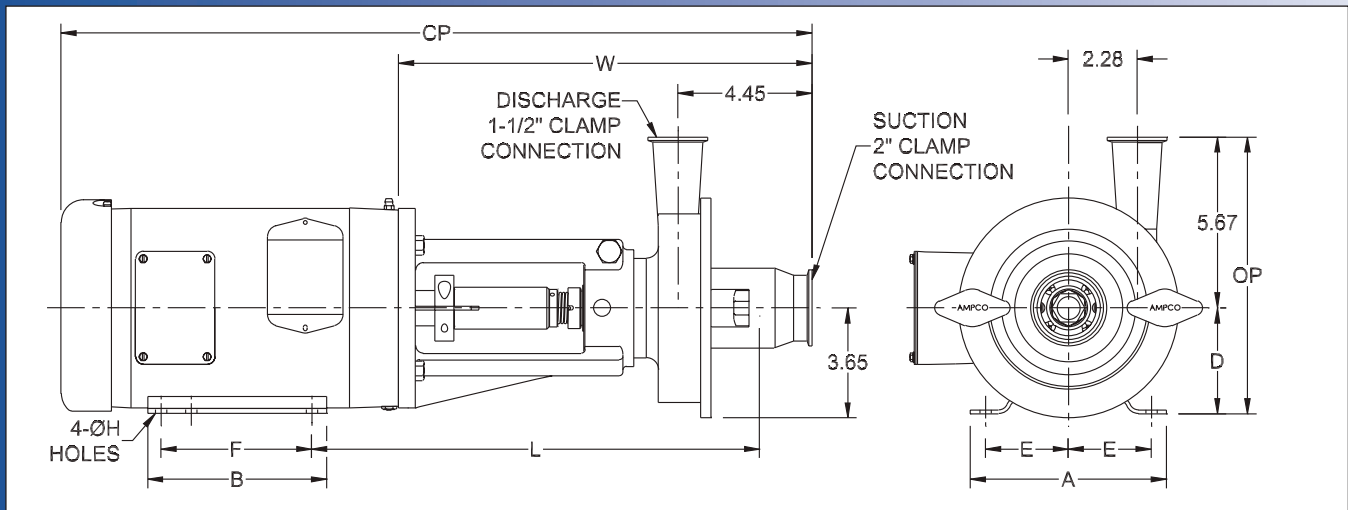
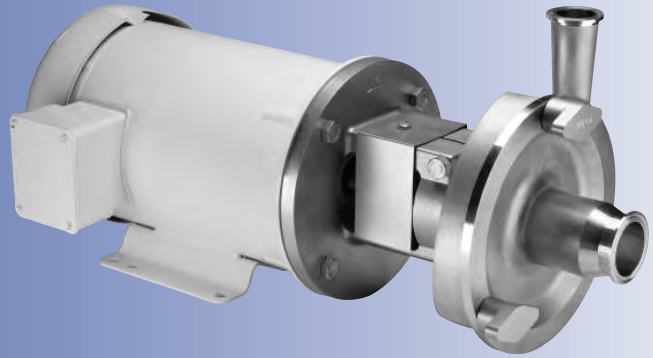

TEFC MOTOR			DIMENSIONS IN INCHES (For Reference Only)										APPROX WEIGHT (LBS)
HP	RPM	FRAME	A (typ)	B (typ)	D	E	F	ØH	L	W	CP	OP	
1	1750	143TC	6-1/2	6	3-1/2	2-3/4	4	11/32	16.44	13.69	24.75	9.17	73
2	3500	145TC	6-1/2	6	3-1/2	2-3/4	5	11/32	16.44	13.69	24.75	9.17	81
3	3500	182TC	8-5/8	6-1/2	4-1/2	3-3/4	4-1/2	13/32	17.20	13.70	26.01	10.17	100
5	3500	184TC	8-5/8	6-1/2	4-1/2	3-3/4	5-1/2	13/32	17.20	13.70	27.38	10.17	114

## MATERIAL SPECIFICATIONS

PART NAME	STAINLESS STEEL
Casing, Cover & Impeller	316L Stainless
Stub Shaft	316L Stainless
Adapter	304 Stainless



**CSI**  
417.831.1411  
csidesigns.com



MODEL LD-R11 2X1½  
 MODEL LD-R12 2X1½

# Ampco Centrifugal Pumps

Curves show approximate characteristics based on clear 68° water. Rated point is guaranteed.

LD-Series pumps have standard stainless steel adapters and silicon carbide vs. carbon internal seals and carbon vs. ceramic external seals.

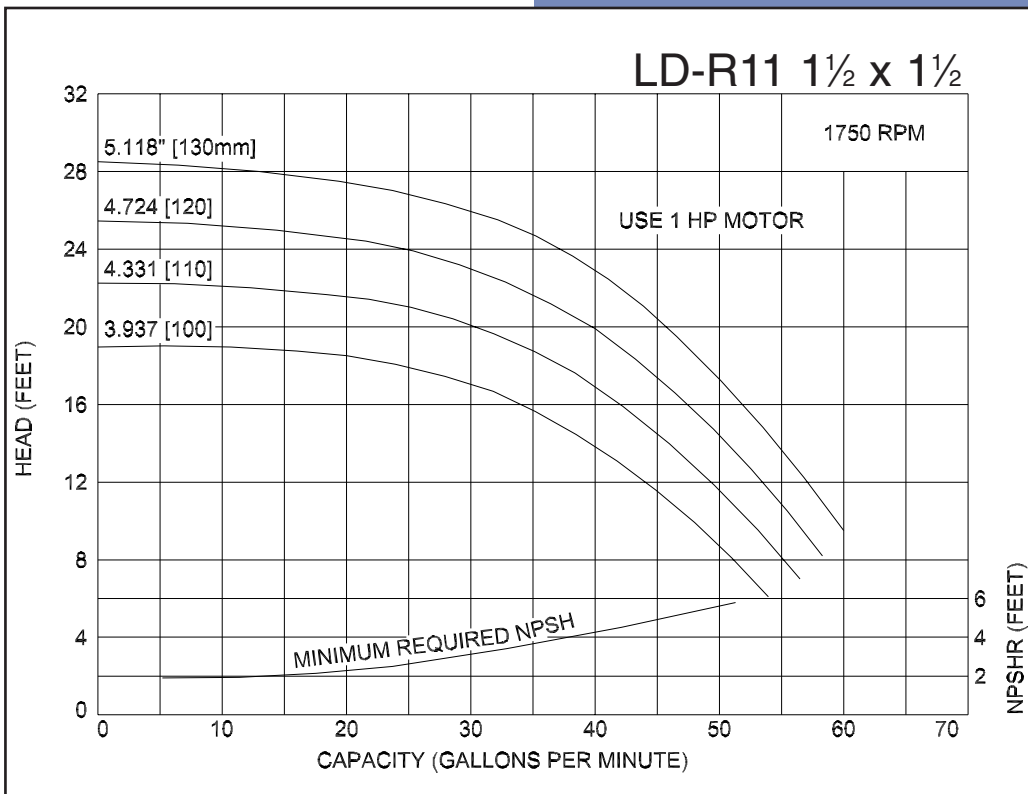
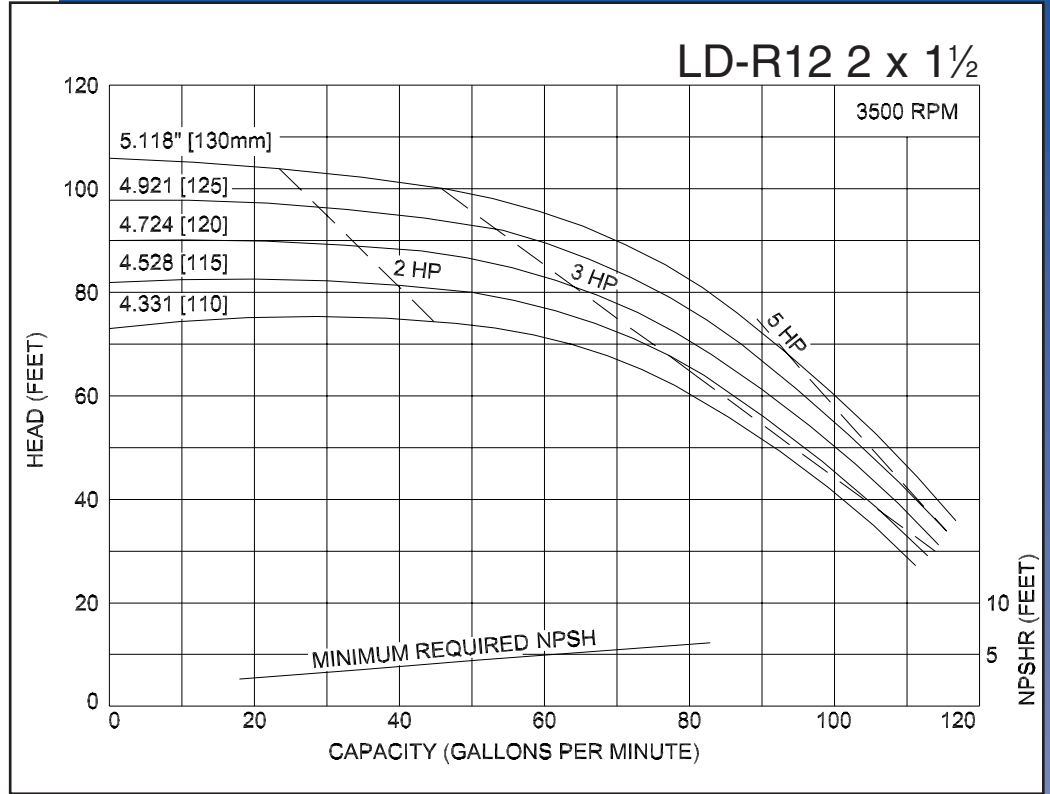

LD pumps are in conformance with 3A sanitary standards for centrifugal and positive rotary pumps for milk and milk products, Number 02-09.

LD-Series pumps have a standard 32RA (150 grit) finish, on all product contact surfaces.

**Ampco  
Pumps  
Company**



**CSI**  
417.831.1411  
csidesigns.com

# Ampco Centrifugal Pumps

## DATA SHEET

MODEL LD-R21 2X1 1/2  
MODEL LD-R22 2X1 1/2

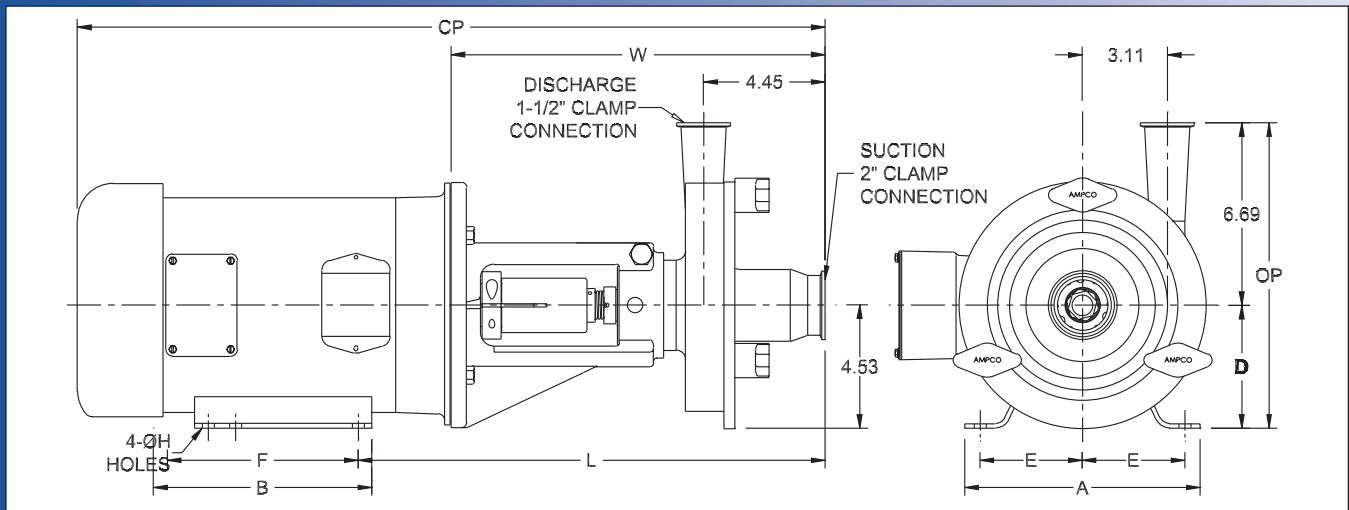
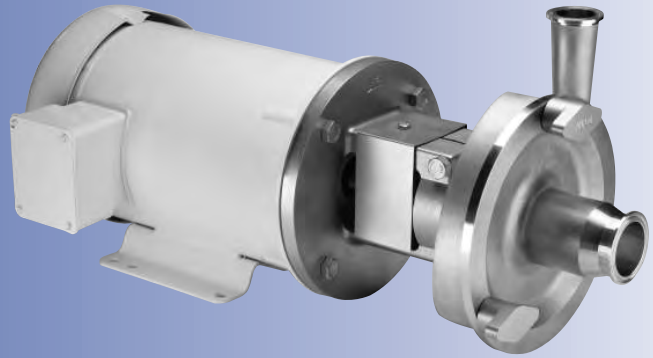

TEFC MOTOR			DIMENSIONS IN INCHES (For Reference Only)										APPROX WEIGHT (LBS)
HP	RPM	FRAME	A (typ)	B (typ)	D	E	F	ØH	L	W	CP	OP	
1	1750	143TC	6-1/2	6	3-1/2	2-3/4	4	11/32	16.44	13.69	24.75	10.19	80
1-1/2	1750	145TC	6-1/2	6	3-1/2	2-3/4	5	11/32	16.44	13.69	24.75	10.19	86
3	3500	182TC	8-5/8	6-1/2	4-1/2	3-3/4	4-1/2	13/32	17.20	13.70	26.01	11.19	107
5	3500	184TC	8-5/8	6-1/2	4-1/2	3-3/4	5-1/2	13/32	17.20	13.70	27.38	11.19	121
7-1/2	3500	184TC	8-5/8	6-1/2	4-1/2	3-3/4	5-1/2	13/32	17.20	13.70	28.88	11.19	139
10	3500	215TC	9-1/2	8	5-1/4	4-1/4	7	13/32	17.95	13.70	28.97	11.94	173

## MATERIAL SPECIFICATIONS

PART NAME	STAINLESS STEEL
Casing, Cover & Impeller	316L Stainless
Stub Shaft	316L Stainless
Adapter	304 Stainless



**CSI**  
417.831.1411  
csidesigns.com



MODEL LD-R21 2X1½  
 MODEL LD-R22 2X1½

# Ampco Centrifugal Pumps

Curves show approximate characteristics based on clear 68° water. Rated point is guaranteed.

LD-Series pumps have standard stainless steel adapters and silicon carbide vs. carbon internal seals and carbon vs. ceramic external seals.

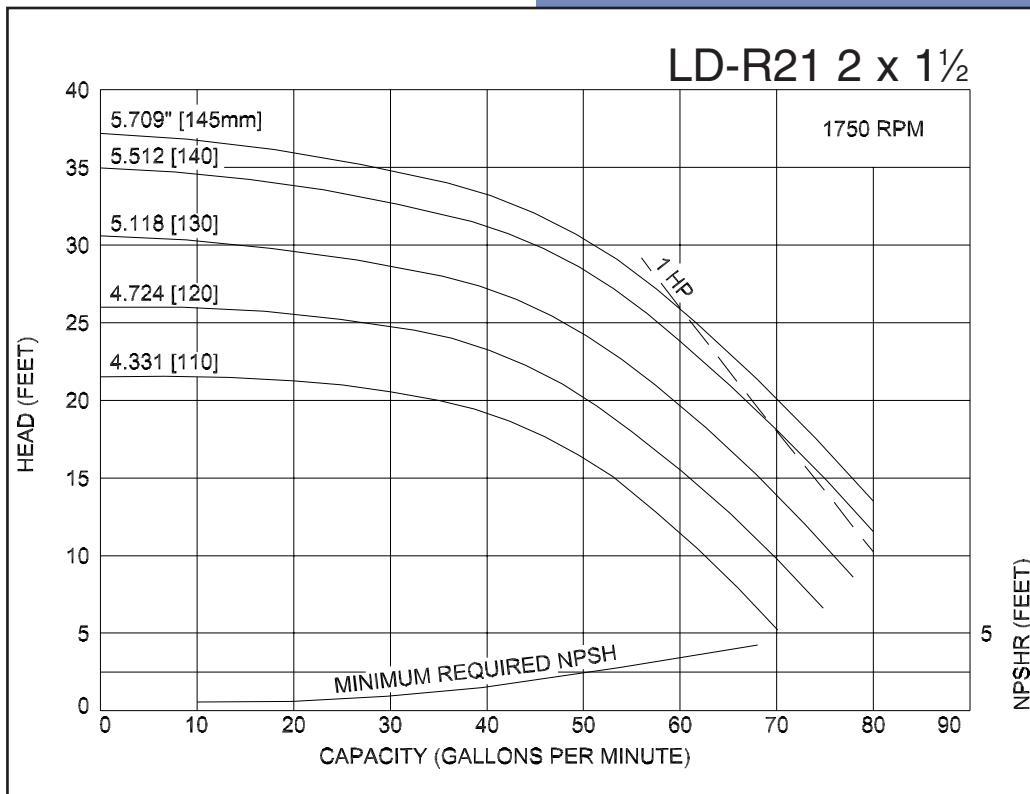
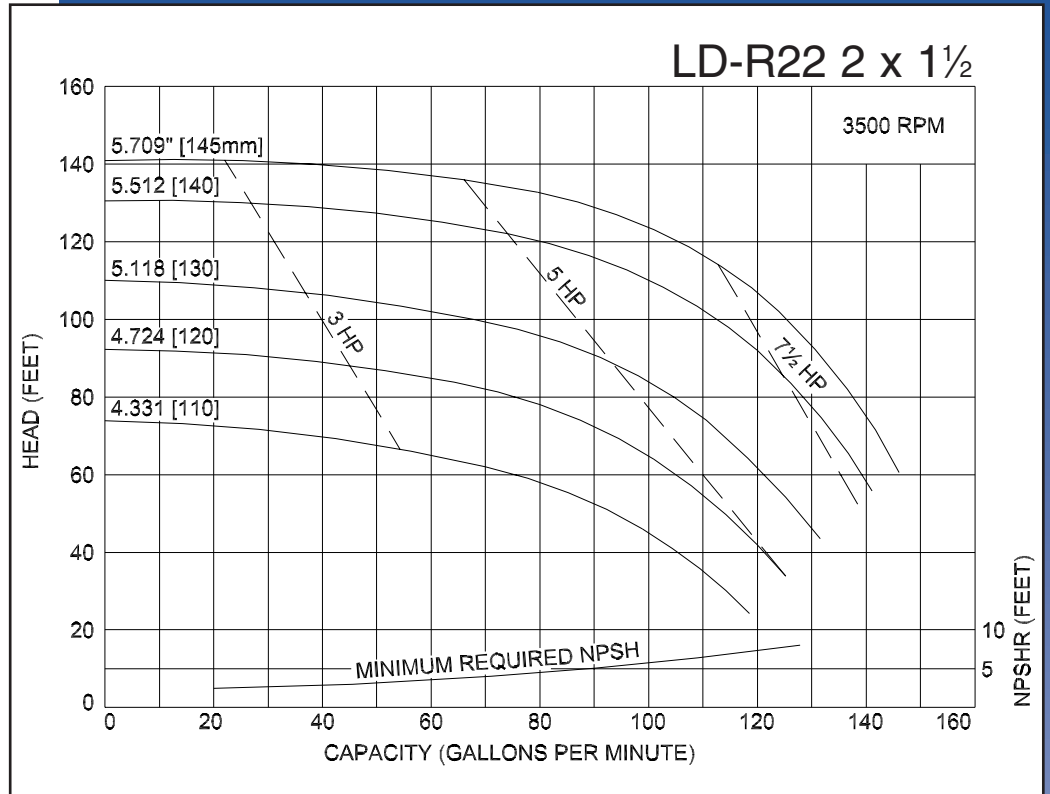

LD pumps are in conformance with 3A sanitary standards for centrifugal and positive rotary pumps for milk and milk products, Number 02-09.

LD-Series pumps have a standard 32RA (150 grit) finish, on all product contact surfaces.

**Ampco  
Pumps  
Company**



**CSI**  
 417.831.1411  
 csidesigns.com

# Ampco Centrifugal Pumps

## DATA SHEET

MODEL LD-R31 2X1 1/2

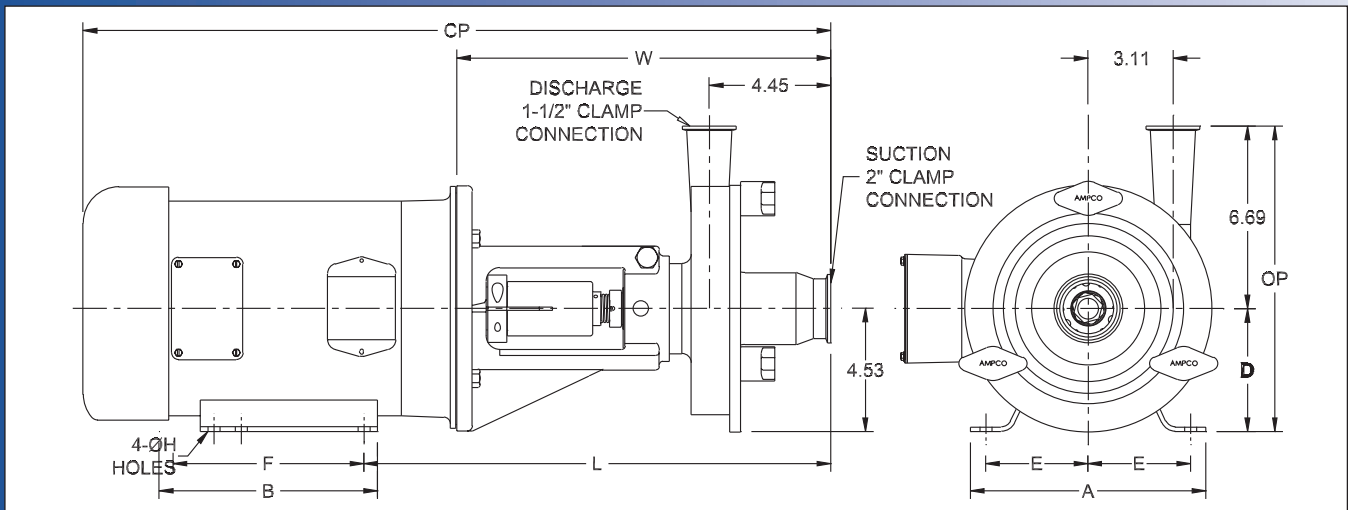
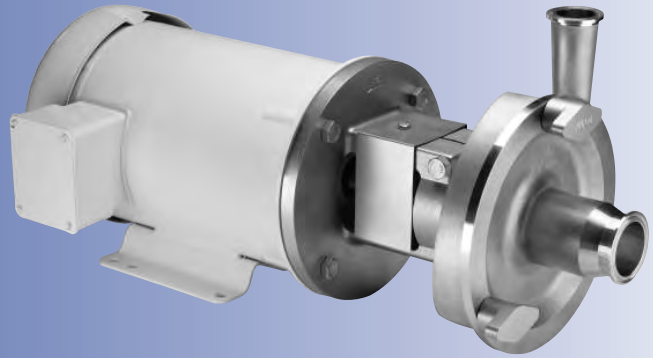

TEFC MOTOR			DIMENSIONS IN INCHES (For Reference Only)										APPROX WEIGHT (LBS)
HP	RPM	FRAME	A (typ)	B (typ)	D	E	F	ØH	L	W	CP	OP	
1	1750	143TC	6-1/2	6	3-1/2	2-3/4	4	11/32	16.44	13.69	24.75	10.19	80
1-1/2	1750	145TC	6-1/2	6	3-1/2	2-3/4	5	11/32	16.44	13.69	24.75	10.19	86
2	1750	145TC	6-1/2	6	3-1/2	2-3/4	5	11/32	16.44	13.69	24.75	10.19	89
3	1750	182TC	8-5/8	6-1/2	4-1/2	3-3/4	4-1/2	13/32	17.20	13.70	27.39	11.19	119

## MATERIAL SPECIFICATIONS

PART NAME	STAINLESS STEEL
Casing, Cover & Impeller	316L Stainless
Stub Shaft	316L Stainless
Adapter	304 Stainless



**CSI**  
417.831.1411  
csidesigns.com



# Ampco Centrifugal Pumps

MODEL LD-R31 2X 1½

Curves show approximate characteristics based on clear 68° water.  
Rated point is guaranteed.

LD-Series pumps have standard stainless steel adapters and silicon carbide vs. carbon internal seals and carbon vs. ceramic external seals.

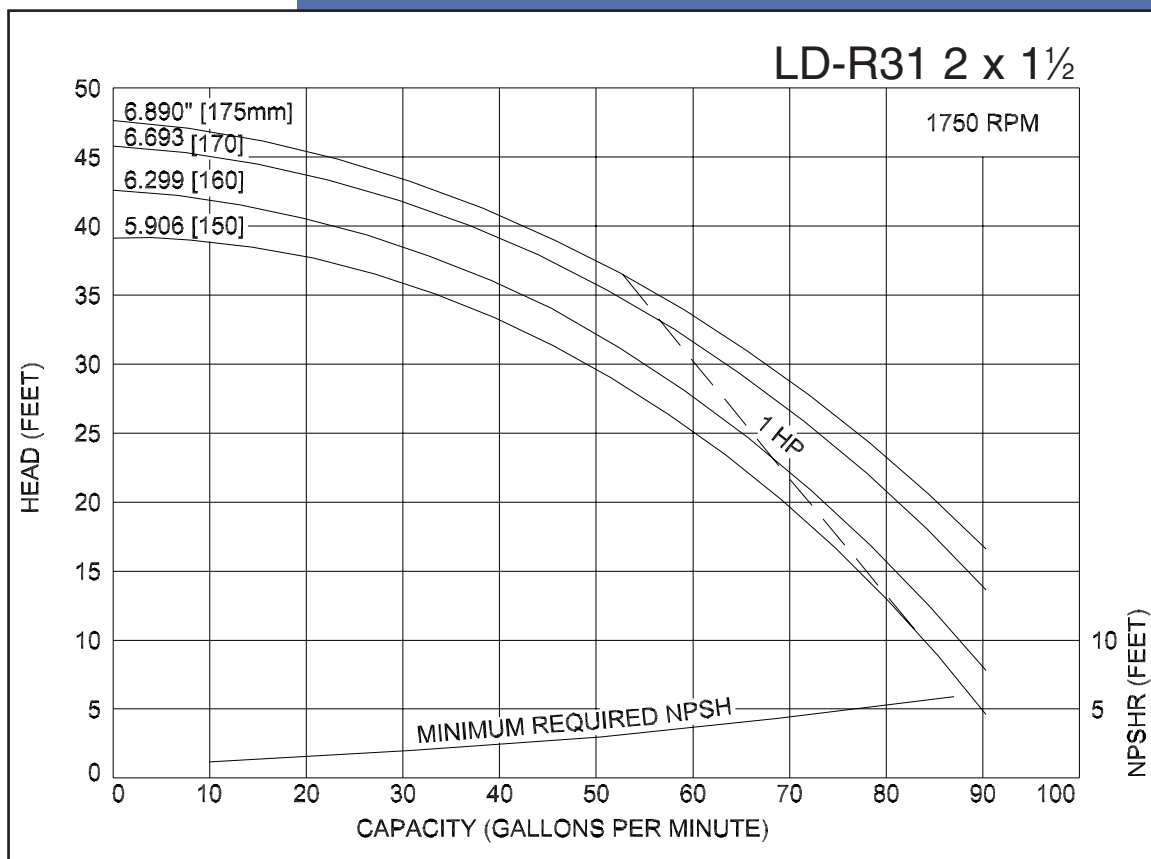

LD pumps are in conformance with 3A sanitary standards for centrifugal and positive rotary pumps for milk and milk products, Number 02-09.

LD-Series pumps have a standard 32RA (150 grit) finish, on all product contact surfaces.



**CSI**

417.831.1411  
csidesigns.com



# Ampco Centrifugal Pumps

DATA SHEET

MODEL LD-R32 2½X2

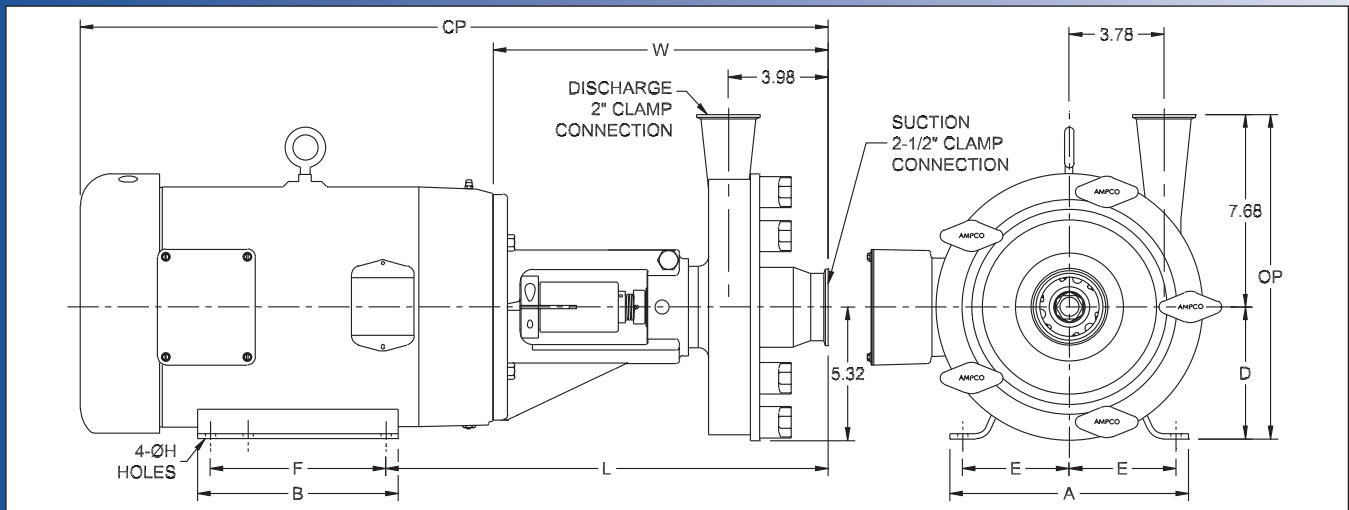
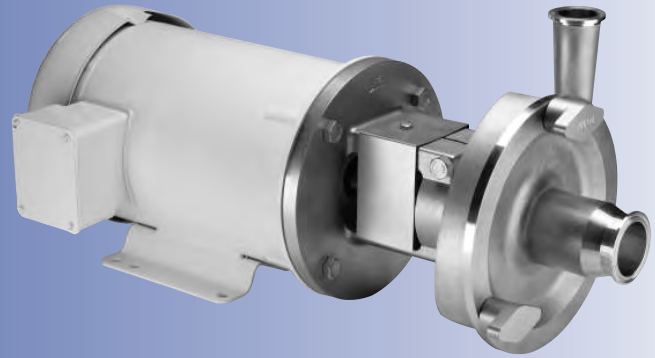

TEFC MOTOR			DIMENSIONS IN INCHES (For Reference Only)										APPROX WEIGHT (LBS)
HP	RPM	FRAME	A (typ)	B (typ)	D	E	F	ØH	L	W	CP	OP	
3	3500	182TC	8-5/8	6-1/2	4-1/2	3-3/4	4-1/2	13/32	16.85	13.35	25.66	12.18	121
5	3500	184TC	8-5/8	6-1/2	4-1/2	3-3/4	5-1/2	13/32	16.85	13.35	27.03	12.18	135
7-1/2	3500	184TC	8-5/8	6-1/2	4-1/2	3-3/4	5-1/2	13/32	16.85	13.35	28.53	12.18	153
10	3500	215TC	9-1/2	8	5-1/4	4-1/4	7	13/32	17.60	13.35	28.62	12.93	187
15	3500	215TC	9-1/2	8	5-1/4	4-1/4	7	13/32	17.60	13.35	30.50	12.93	227

## MATERIAL SPECIFICATIONS

PART NAME	STAINLESS STEEL
Casing, Cover & Impeller	316L Stainless
Stub Shaft	316L Stainless
Adapter	304 Stainless



**CSI**  
417.831.1411  
csidesigns.com



# Ampco Centrifugal Pumps

MODEL LD-R32 2½ X 2

Curves show approximate characteristics based on clear 68° water.  
Rated point is guaranteed.

LD-Series pumps have standard stainless steel adapters and silicon carbide vs. carbon internal seals and carbon vs. ceramic external seals.

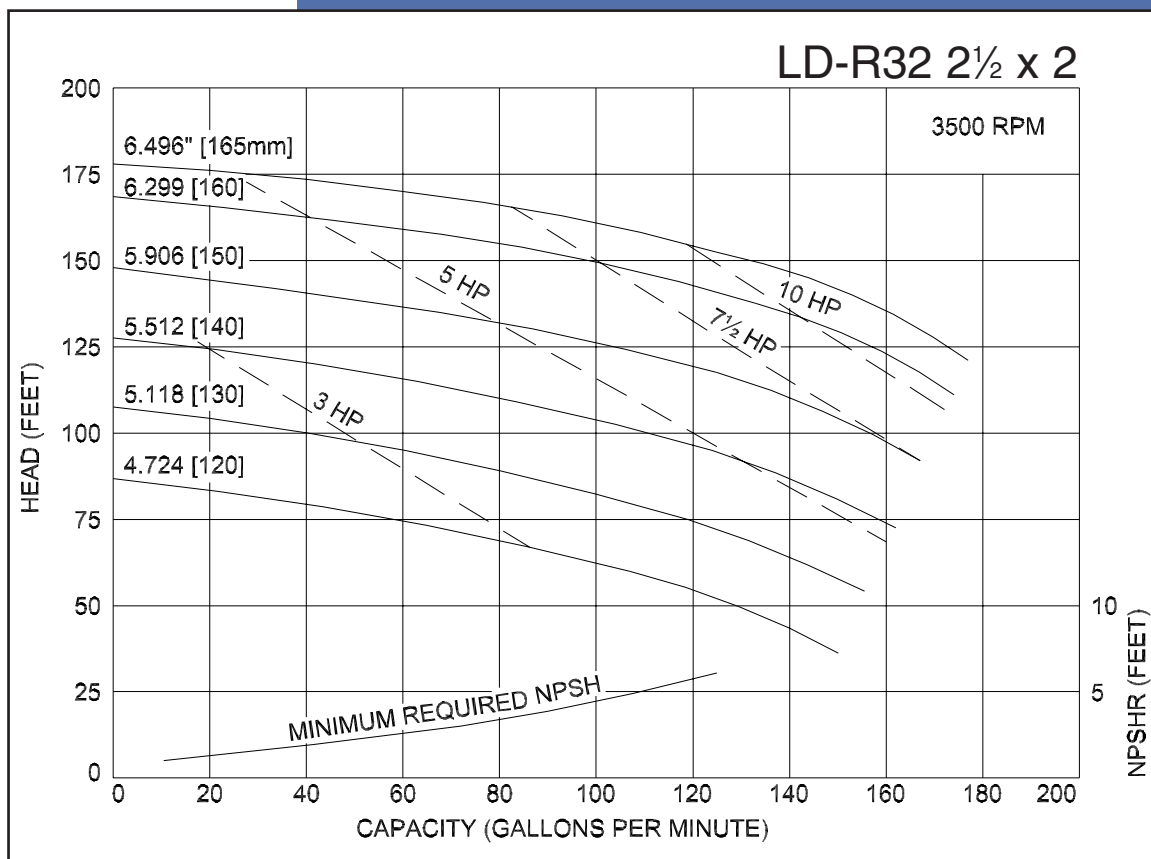

LD pumps are in conformance with 3A sanitary standards for centrifugal and positive rotary pumps for milk and milk products, Number 02-09.

LD-Series pumps have a standard 32RA (150 grit) finish, on all product contact surfaces.



**CSI**

417.831.1411  
csidesigns.com

# Ampco Centrifugal Pumps

## DATA SHEET

MODEL LD-R41 2 1/2 X 2  
MODEL LD-R42 2 1/2 X 2

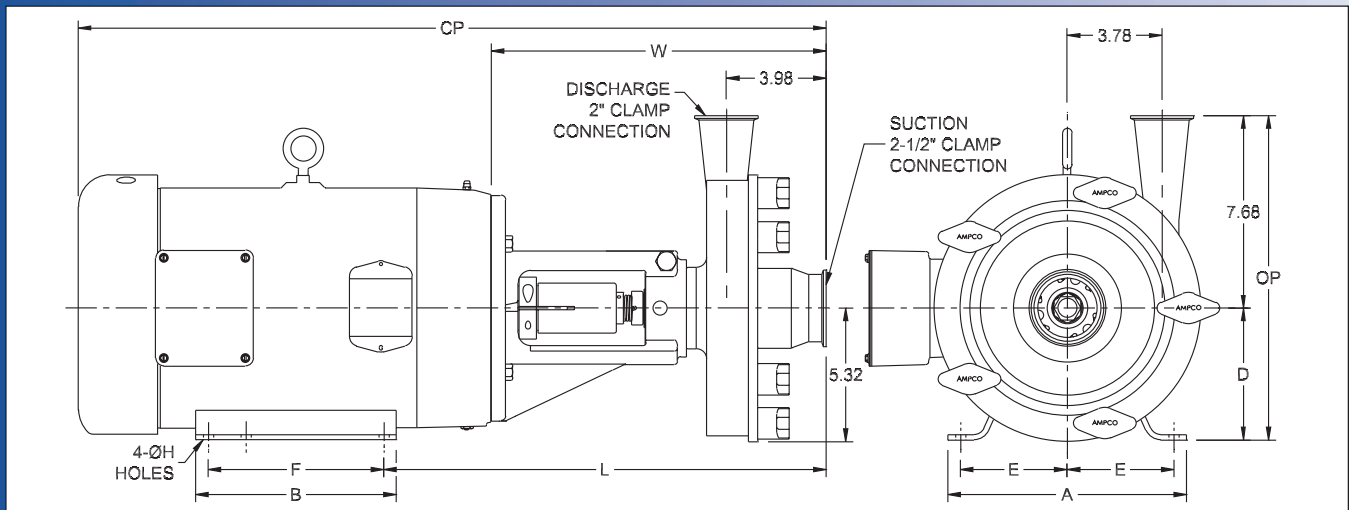
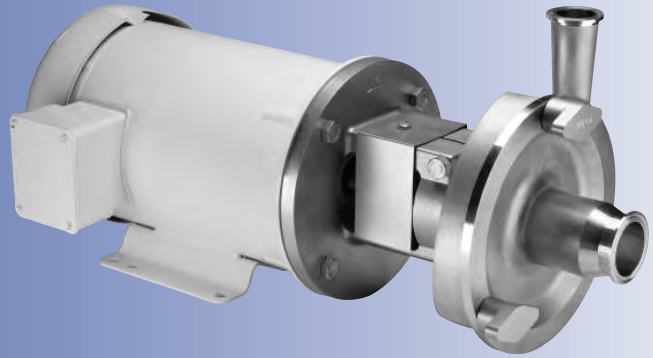

TEFC MOTOR			DIMENSIONS IN INCHES (For Reference Only)										APPROX WEIGHT (LBS)
HP	RPM	FRAME	A (typ)	B (typ)	D	E	F	ØH	L	W	CP	OP	
1	1750	143TC	6-1/2	6	3-1/2	2-3/4	4	11/32	16.09	13.34	24.40	11.18	93
1-1/2	1750	145TC	6-1/2	6	3-1/2	2-3/4	5	11/32	16.09	13.34	24.40	11.18	100
2	1750	145TC	6-1/2	6	3-1/2	2-3/4	5	11/32	16.09	13.34	24.40	11.18	103
3	1750	182TC	8-5/8	6-1/2	4-1/2	3-3/4	4-1/2	13/32	16.85	13.35	27.04	12.18	133
7-1/2	3500	184TC	8-5/8	6-1/2	4-1/2	3-3/4	5-1/2	13/32	16.85	13.35	28.53	12.18	153
10	3500	215TC	9-1/2	8	5-1/4	4-1/4	7	13/32	17.60	13.35	28.62	12.93	187
15	3500	215TC	9-1/2	8	5-1/4	4-1/4	7	13/32	17.60	13.35	30.50	12.93	227
20	3500	256TC	11-1/2	11-1/2	6-1/4	5	10	17/32	18.27	13.52	34.65	13.93	354
25	3500	284TSC	12-3/4	12-3/4	7	5-1/2	9-1/2	17/32	18.27	13.52	36.65	14.68	447

## MATERIAL SPECIFICATIONS

PART NAME	STAINLESS STEEL
Casing, Cover & Impeller	316L Stainless
Stub Shaft	316L Stainless
Adapter	304 Stainless



**CSI**  
417.831.1411  
csidesigns.com



MODEL LD-R41 2½ X2  
 MODEL LD-R42 2½ X2

# Ampco Centrifugal Pumps

Curves show approximate characteristics based on clear 68° water.  
 Rated point is guaranteed.

LD-Series pumps have standard stainless steel adapters and silicon carbide vs. carbon internal seals and carbon vs. ceramic external seals.

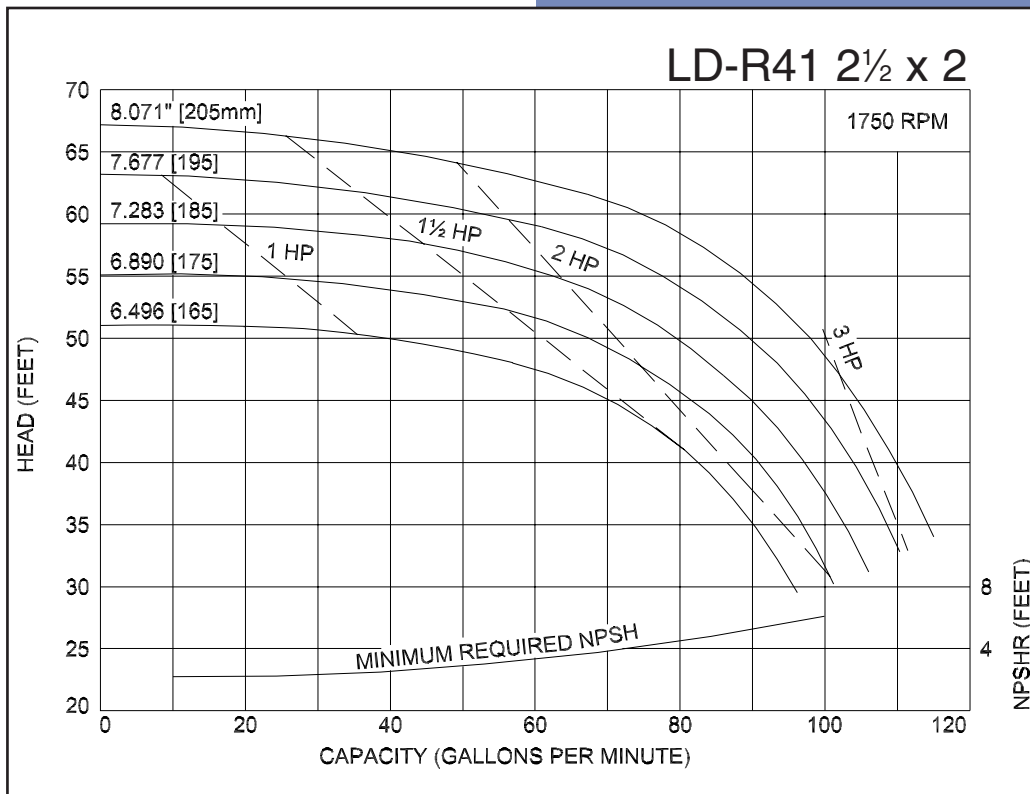
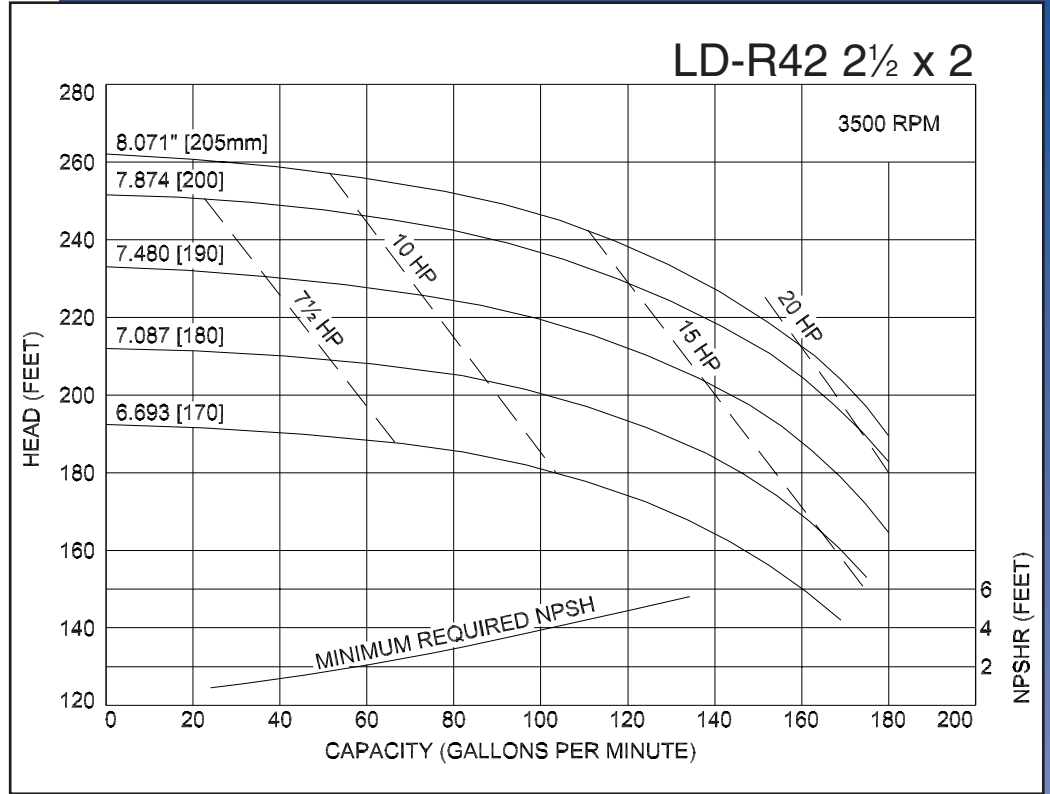

LD pumps are in conformance with 3A sanitary standards for centrifugal and positive rotary pumps for milk and milk products, Number 02-09.

LD-Series pumps have a standard 32RA (150 grit) finish, on all product contact surfaces.

**Ampco  
 Pumps  
 Company**



**CSI**  
 417.831.1411  
 csidesigns.com

# Ampco Centrifugal Pumps

## DATA SHEET

MODEL LD-R132 2 1/2 X 2

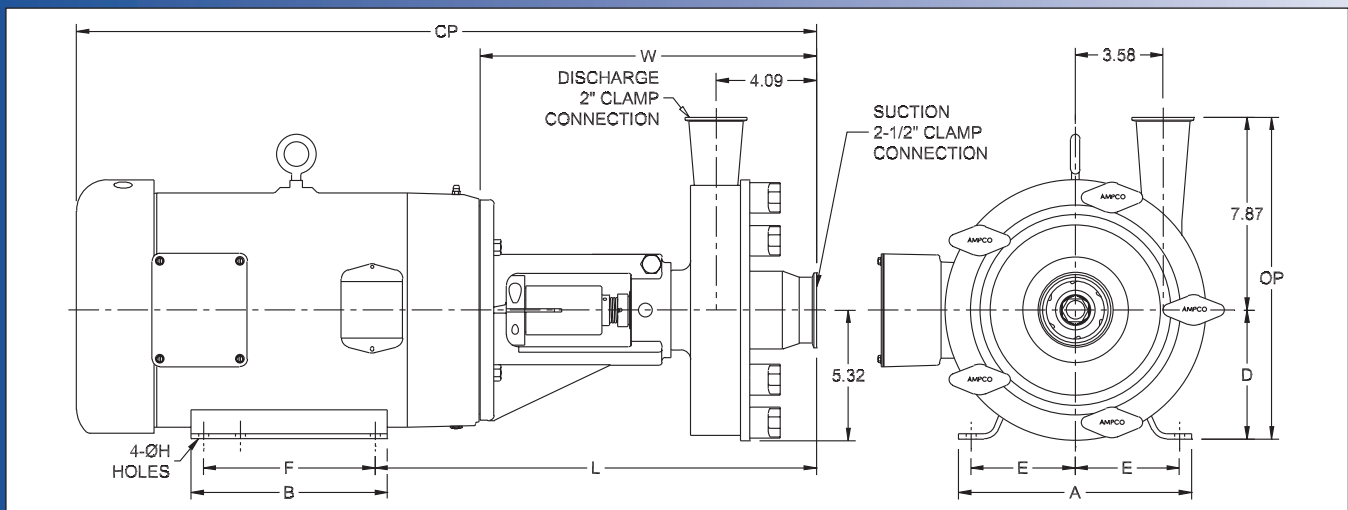
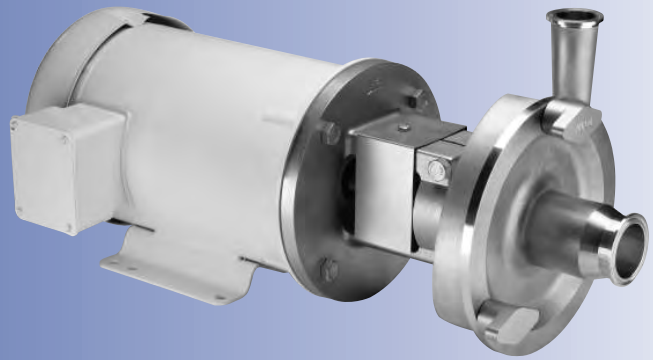

TEFC MOTOR			DIMENSIONS IN INCHES (For Reference Only)										APPROX WEIGHT (LBS)
HP	RPM	FRAME	A (typ)	B (typ)	D	E	F	ØH	L	W	CP	OP	
7-1/2	3500	184TC	8-5/8	6-1/2	4-1/2	3-3/4	5-1/2	13/32	17.23	13.73	28.91	12.37	163
10	3500	215TC	9-1/2	8	5-1/4	4-1/4	7	13/32	17.98	13.73	29.00	13.12	193
15	3500	215TC	9-1/2	8	5-1/4	4-1/4	7	13/32	17.98	13.73	30.88	13.12	235
20	3500	256TC	11-1/2	11-1/2	6-1/4	5	10	17/32	18.64	13.89	35.02	14.12	360
25	3500	284TSC	12-3/4	12-3/4	7	5-1/2	9-1/2	17/32	18.64	13.89	37.02	14.87	453
30	3500	286TSC	12-3/4	12-3/4	7	5-1/2	11	17/32	18.64	13.89	37.02	14.87	475

## MATERIAL SPECIFICATIONS

PART NAME	STAINLESS STEEL
Casing, Cover & Impeller	316L Stainless
Stub Shaft	316L Stainless
Adapter	304 Stainless



**CSI**

417.831.1411  
csidesigns.com



# Ampco Centrifugal Pumps

MODEL LD-R132 2 1/2 X 2

Curves show approximate characteristics based on clear 68° water.  
Rated point is guaranteed.

LD-Series pumps have standard stainless steel adapters and silicon carbide vs. carbon internal seals and carbon vs. ceramic external seals.

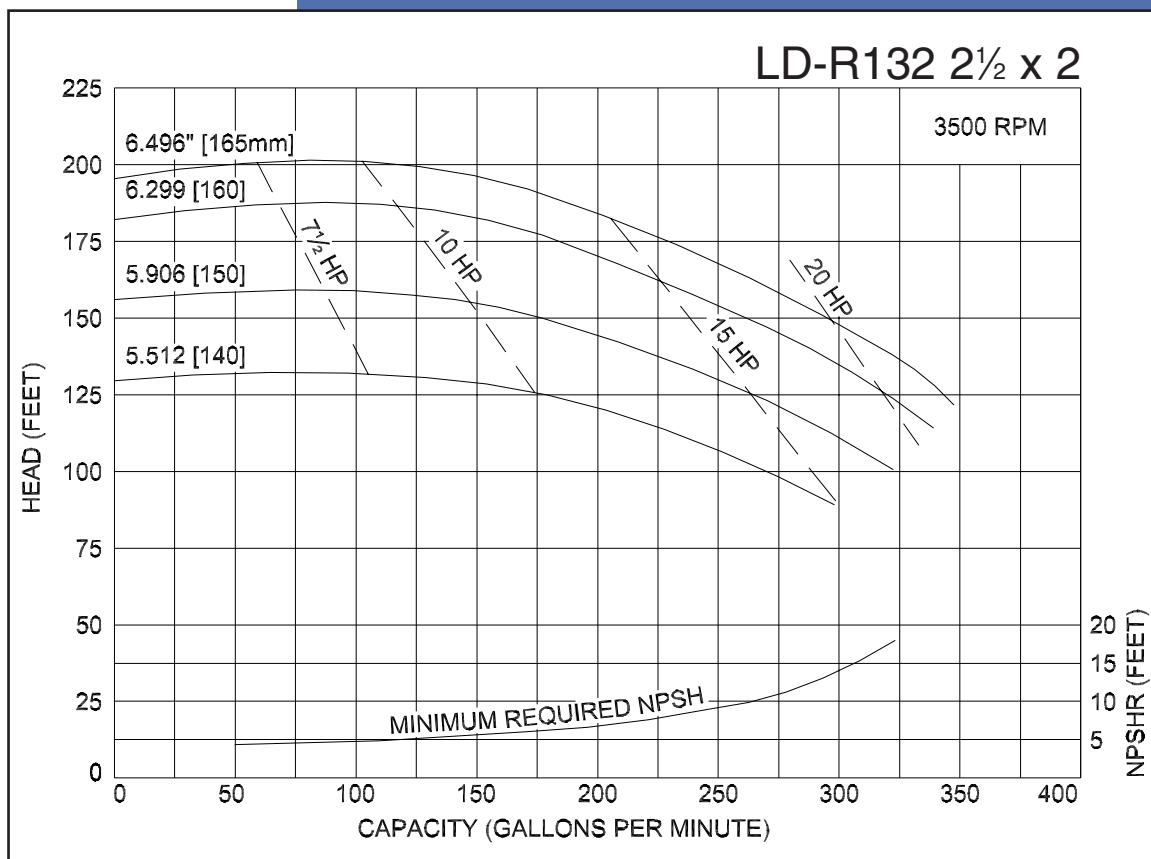

LD pumps are in conformance with 3A sanitary standards for centrifugal and positive rotary pumps for milk and milk products, Number 02-09.

LD-Series pumps have a standard 32RA (150 grit) finish, on all product contact surfaces.



**CSI**

417.831.1411  
csidesigns.com

# Ampco Centrifugal Pumps

## DATA SHEET

MODEL LD-R141 2 1/2 X2  
MODEL LD-R142 2 1/2 X2

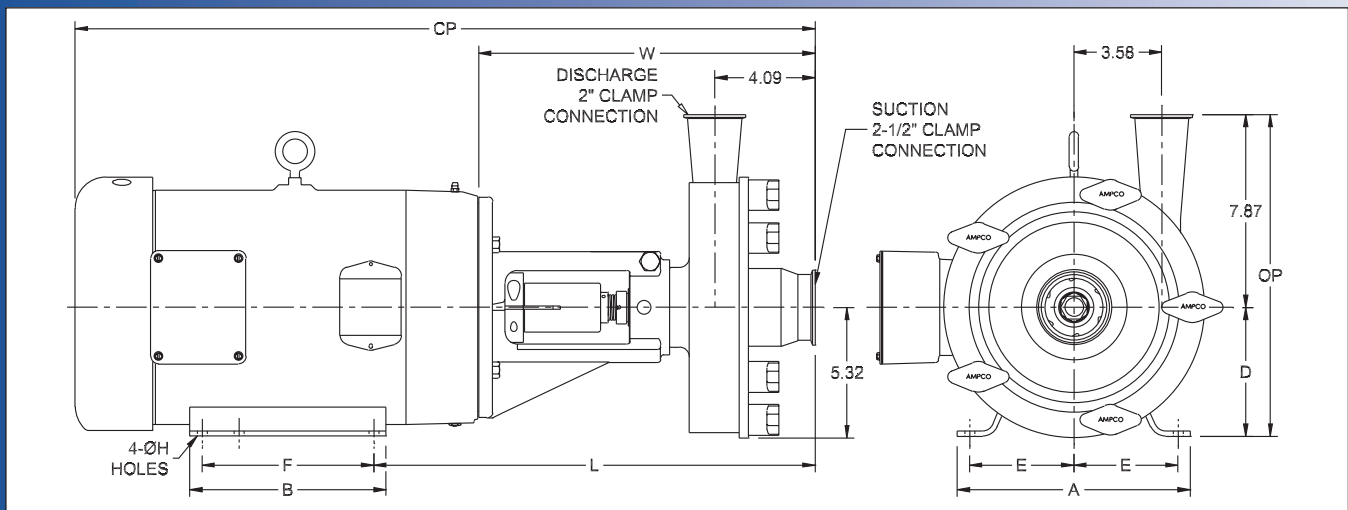
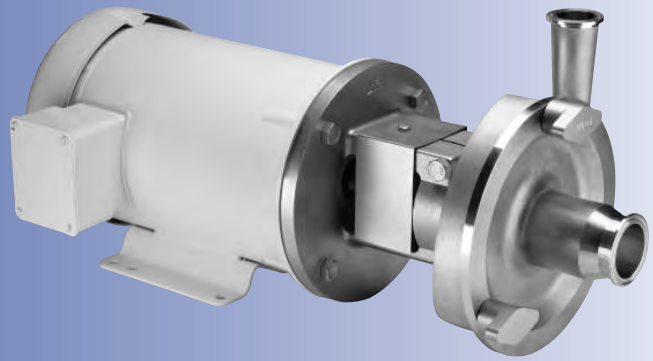

TEFC MOTOR			DIMENSIONS IN INCHES (For Reference Only)										APPROX WEIGHT (LBS)
HP	RPM	FRAME	A (typ)	B (typ)	D	E	F	ØH	L	W	CP	OP	
1	1750	143TC	6-1/2	6	3-1/2	2-3/4	4	11/32	15.67	12.92	24.78	11.37	104
1-1/2	1750	145TC	6-1/2	6	3-1/2	2-3/4	5	11/32	15.67	12.92	24.78	11.37	110
2	1750	145TC	6-1/2	6	3-1/2	2-3/4	5	11/32	15.67	12.92	24.78	11.37	113
3	1750	182TC	8-5/8	6-1/2	4-1/2	3-3/4	4-1/2	13/32	18.03	14.53	27.42	12.37	140
5	1750	184TC	8-5/8	6-1/2	4-1/2	3-3/4	5-1/2	13/32	18.03	14.53	28.91	12.37	147
7-1/2	1750	213TC	9-1/2	8	5-1/4	4-1/4	5-1/2	13/32	18.78	14.53	29.00	13.12	164
10	3500	215TC	9-1/2	8	5-1/4	4-1/4	7	13/32	18.78	14.53	29.00	13.12	194
15	3500	215TC	9-1/2	8	5-1/4	4-1/4	7	13/32	18.78	14.53	30.88	13.12	236
20	3500	256TC	11-1/2	11-1/2	6-1/4	5	10	17/32	18.64	13.89	35.02	14.12	361
25	3500	284TSC	12-3/4	12-3/4	7	5-1/2	9-1/2	17/32	18.64	13.89	37.02	14.87	454
30	3500	286TSC	12-3/4	12-3/4	7	5-1/2	11	17/32	18.64	13.89	37.02	14.87	476
40	3500	324TSC	14-1/2	14	8	6-1/4	10-1/2	21/32	19.77	14.52	39.52	15.87	590
50	3500	326TSC	14-1/2	14	8	6-1/4	12	21/32	19.77	14.52	39.52	15.87	699

## MATERIAL SPECIFICATIONS

PART NAME	STAINLESS STEEL
Casing, Cover & Impeller	316L Stainless
Stub Shaft	316L Stainless
Adapter	304 Stainless



**CSI**

417.831.1411  
csidesigns.com



# Ampco Centrifugal Pumps

MODEL LD-R141 2 1/2 X 2  
 MODEL LD-R142 2 1/2 X 2

Curves show approximate characteristics based on clear 68° water. Rated point is guaranteed.

LD-Series pumps have standard stainless steel adapters and silicon carbide vs. carbon internal seals and carbon vs. ceramic external seals.

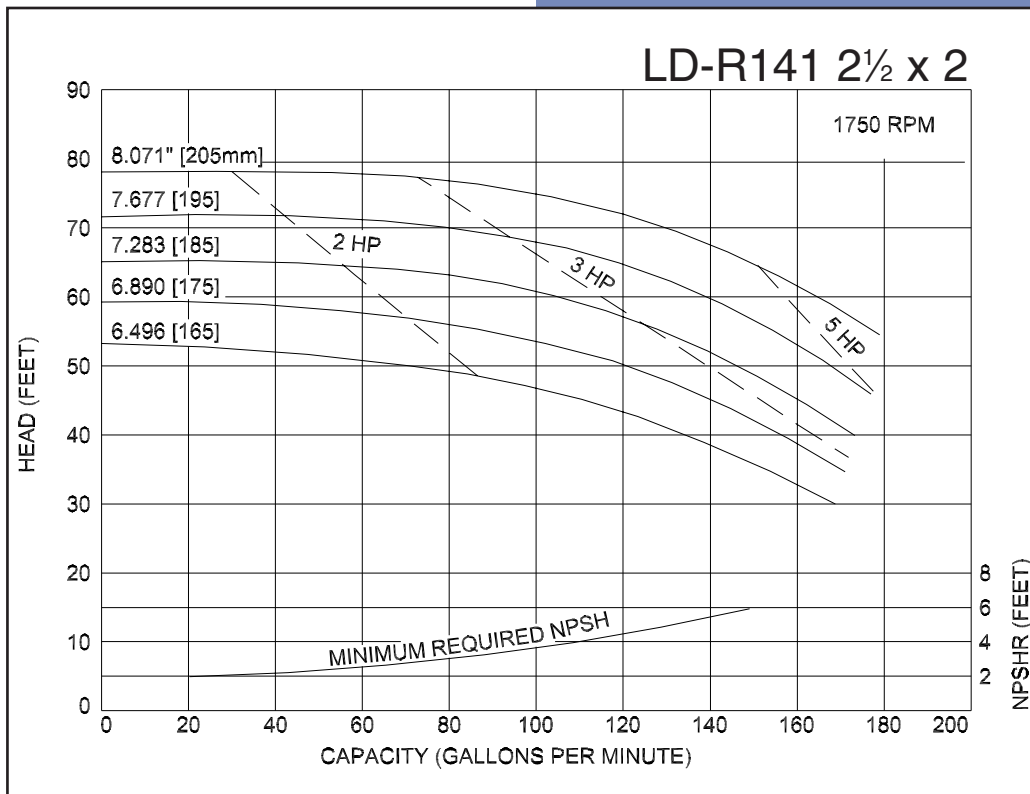
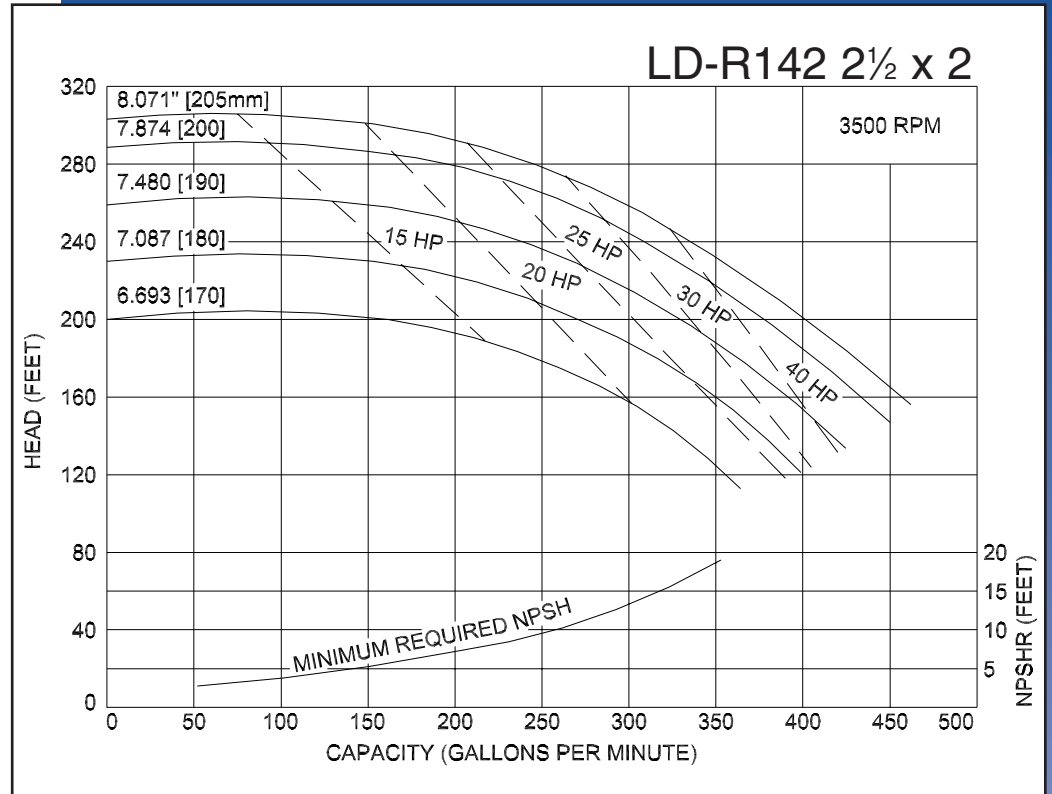

LD pumps are in conformance with 3A sanitary standards for centrifugal and positive rotary pumps for milk and milk products, Number 02-09.

LD-Series pumps have a standard 32RA (150 grit) finish, on all product contact surfaces.

**Ampco  
 Pumps  
 Company**



**CSI**

417.831.1411  
 csidesigns.com



# Ampco Centrifugal Pumps

## DATA SHEET

MODEL LD-V521 2 1/2 X2  
MODEL LD-V522 2 1/2 X2

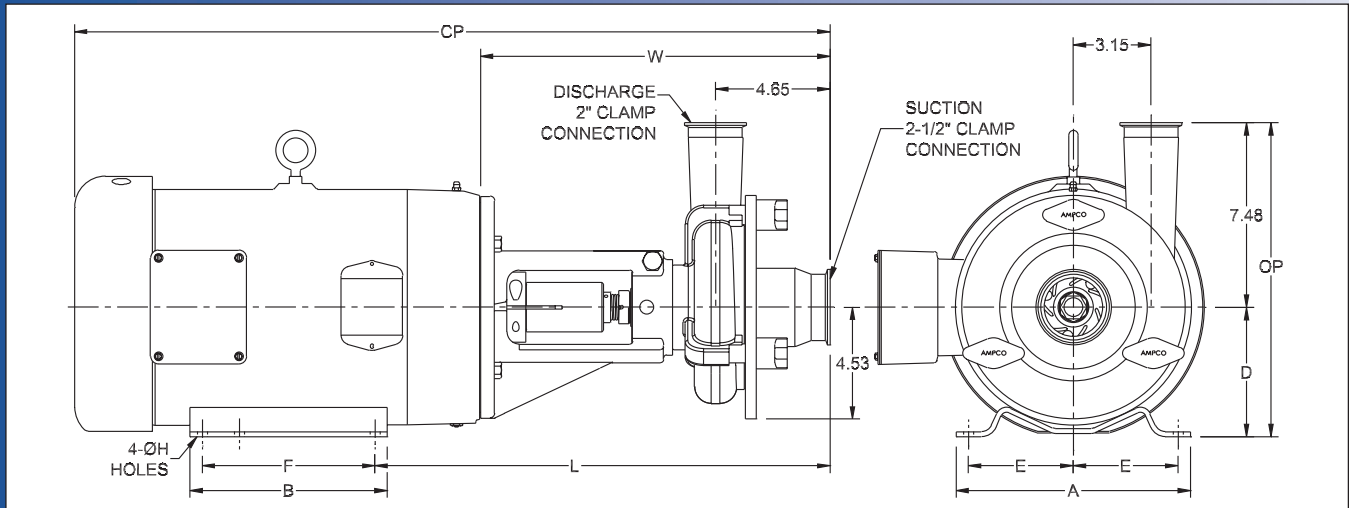
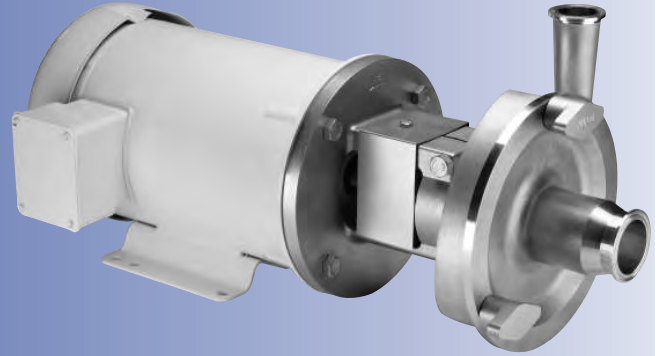

TEFC MOTOR			DIMENSIONS IN INCHES (For Reference Only)										APPROX WEIGHT (LBS)
HP	RPM	FRAME	A (typ)	B (typ)	D	E	F	ØH	L	W	CP	OP	
1	1750	143TC	6-1/2	6	3-1/2	2-3/4	4	11/32	16.92	14.17	25.23	10.98	86
1-1/2	1750	145TC	6-1/2	6	3-1/2	2-3/4	5	11/32	16.92	14.17	25.23	10.98	92
2	1750	145TC	6-1/2	6	3-1/2	2-3/4	5	11/32	16.92	14.17	25.23	10.98	95
5	3500	184TC	8-5/8	6-1/2	4-1/2	3-3/4	5-1/2	13/32	17.68	14.18	27.86	11.98	127
7-1/2	3500	184TC	8-5/8	6-1/2	4-1/2	3-3/4	5-1/2	13/32	17.68	14.18	29.36	11.98	145
10	3500	215TC	9-1/2	8	5-1/4	4-1/4	7	13/32	18.43	14.18	29.45	12.73	179
15	3500	215TC	9-1/2	8	5-1/4	4-1/4	7	13/32	18.43	14.18	31.33	12.73	219

### MATERIAL SPECIFICATIONS

PART NAME	STAINLESS STEEL
Casing, Cover & Impeller	316L Stainless
Stub Shaft	316L Stainless
Adapter	304 Stainless



**CSI**

417.831.1411  
csidesigns.com



# Ampco Centrifugal Pumps

MODEL LD-V521 2 1/2 X2  
 MODEL LD-V522 2 1/2 X2

Curves show approximate characteristics based on clear 68° water. Rated point is guaranteed.

LD-Series pumps have standard stainless steel adapters and silicon carbide vs. carbon internal seals and carbon vs. ceramic external seals.

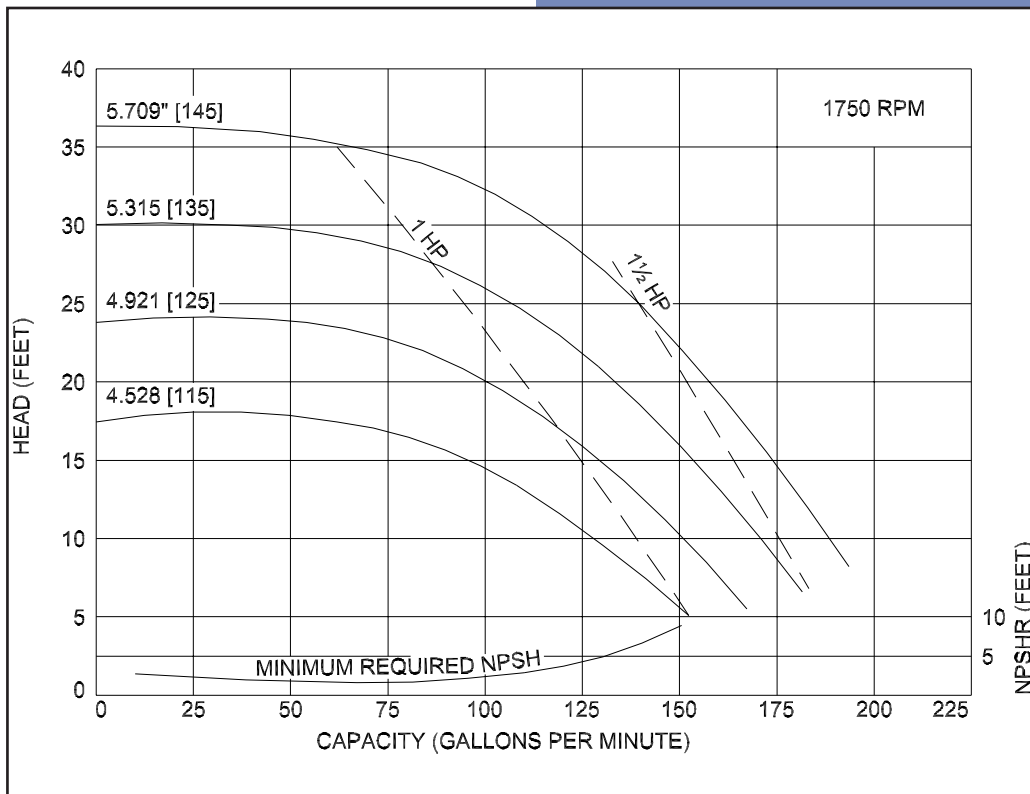
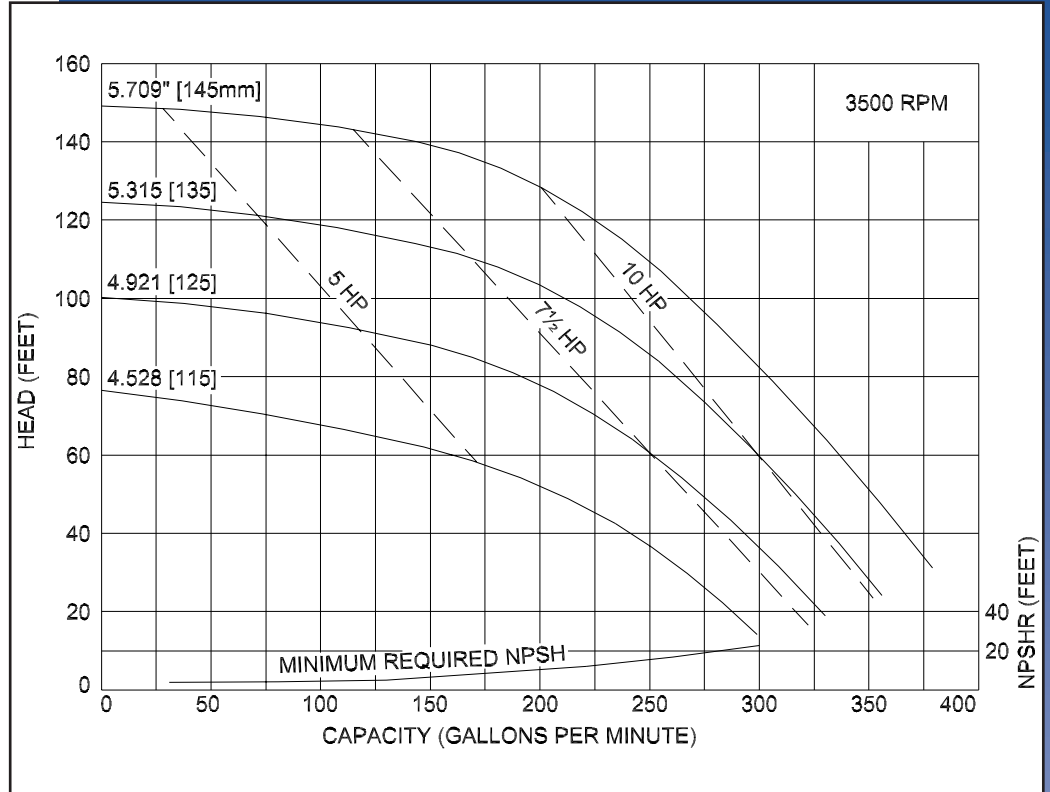

LD pumps are in conformance with 3A sanitary standards for centrifugal and positive rotary pumps for milk and milk products, Number 02-09.

LD-Series pumps have a standard 32RA (150 grit) finish, on all product contact surfaces.

**Ampco  
Pumps  
Company**



**CSI**

417.831.1411  
 csidesigns.com

# Ampco Centrifugal Pumps

## DATA SHEET

MODEL LD-V531 2 1/2 X2  
MODEL LD-V532 2 1/2 X2

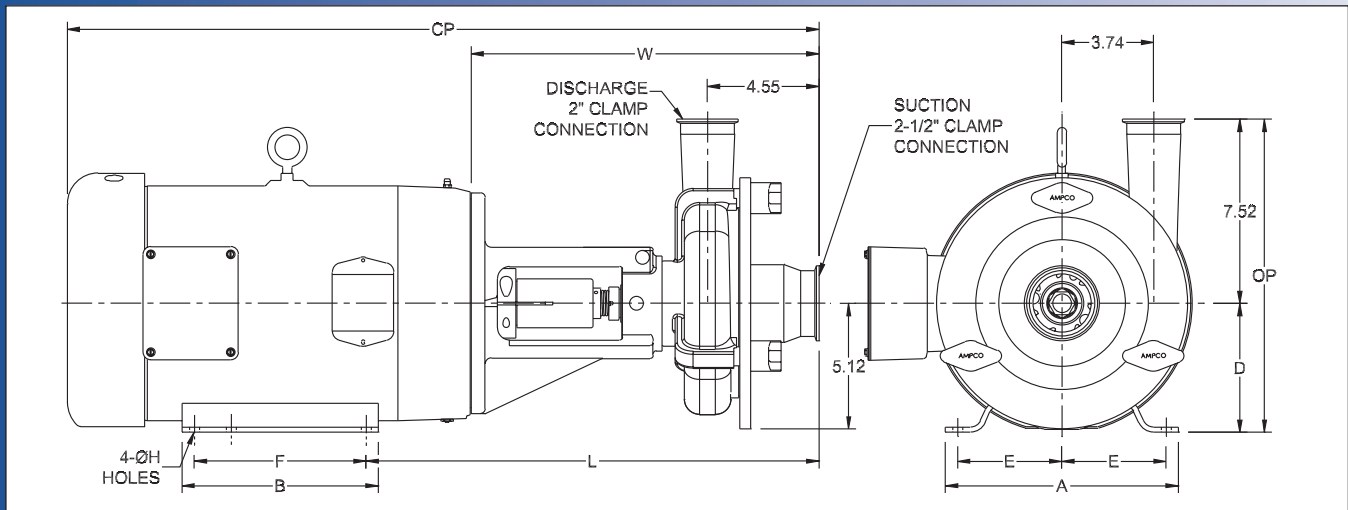
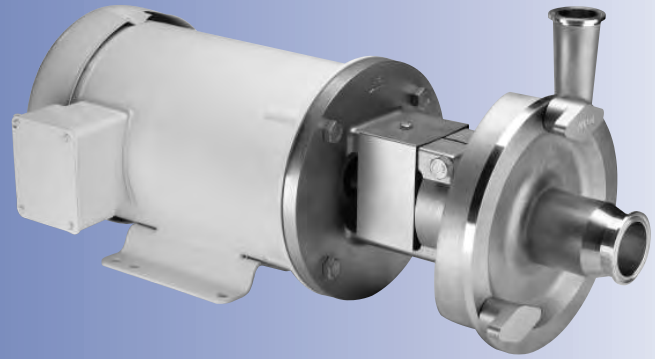

TEFC MOTOR			DIMENSIONS IN INCHES (For Reference Only)										APPROX WEIGHT (LBS)
HP	RPM	FRAME	A (typ)	B (typ)	D	E	F	ØH	L	W	CP	OP	
1	1750	143TC	6-1/2	6	3-1/2	2-3/4	4	11/32	16.92	14.17	25.23	11.02	92
1-1/2	1750	145TC	6-1/2	6	3-1/2	2-3/4	5	11/32	16.92	14.17	25.23	11.02	98
2	1750	145TC	6-1/2	6	3-1/2	2-3/4	5	11/32	16.92	14.17	25.23	11.02	101
3	1750	182TC	8-5/8	6-1/2	4-1/2	3-3/4	4-1/2	13/32	17.68	14.18	27.87	12.02	131
5	1750	184TC	8-5/8	6-1/2	4-1/2	3-3/4	5-1/2	13/32	17.68	14.18	29.36	12.02	138
5	3500	184TC	8-5/8	6-1/2	4-1/2	3-3/4	5-1/2	13/32	17.68	14.18	27.86	12.02	188
7-1/2	3500	184TC	8-5/8	6-1/2	4-1/2	3-3/4	5-1/2	13/32	17.68	14.18	29.36	12.02	198
10	3500	215TC	9-1/2	8	5-1/4	4-1/4	7	13/32	18.43	14.18	29.45	12.77	313
15	3500	215TC	9-1/2	8	5-1/4	4-1/4	7	13/32	18.43	14.18	31.33	12.77	334
20	3500	256TC	11-1/2	11-1/2	6-1/4	5	10	17/32	19.10	14.35	35.48	13.77	376
25	3500	284TSC	12-3/4	12-3/4	7	5-1/2	9-1/2	17/32	19.10	14.35	37.48	14.52	469

### MATERIAL SPECIFICATIONS

PART NAME	STAINLESS STEEL
Casing, Cover & Impeller	316L Stainless
Stub Shaft	316L Stainless
Adapter	304 Stainless



**CSI**

417.831.1411  
csidesigns.com



# Ampco Centrifugal Pumps

MODEL LD-V531 2 1/2 X 2  
 MODEL LD-V532 2 1/2 X 2

Curves show approximate characteristics based on clear 68° water. Rated point is guaranteed.

LD-Series pumps have standard stainless steel adapters and silicon carbide vs. carbon internal seals and carbon vs. ceramic external seals.

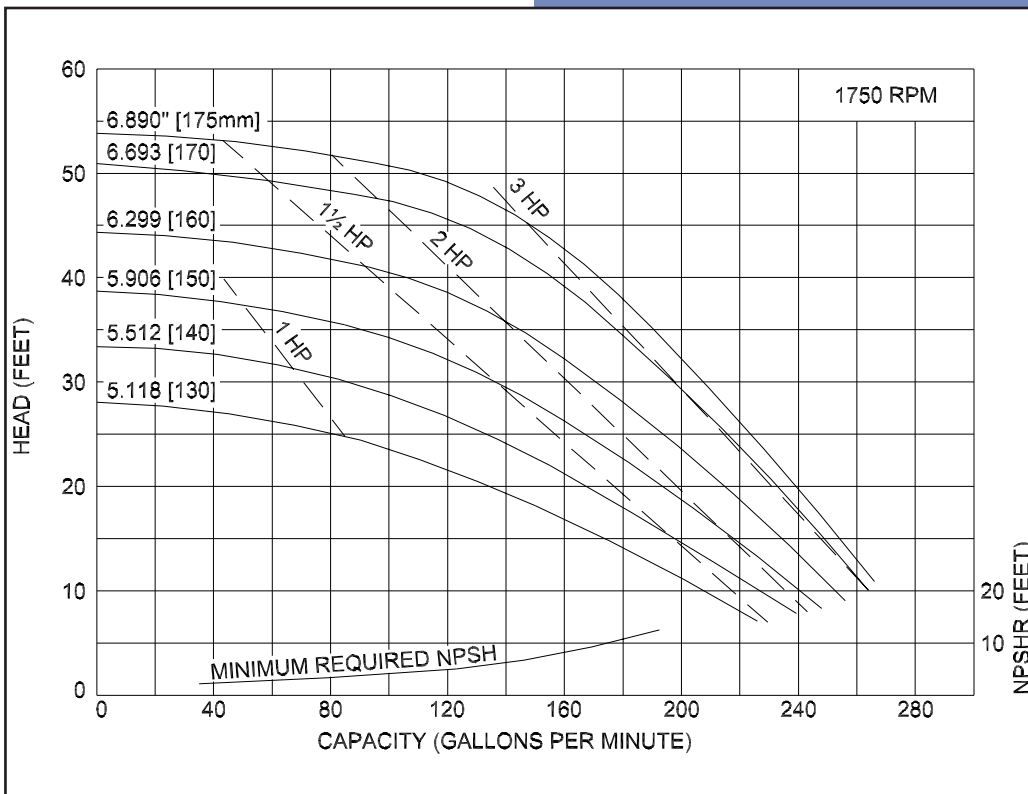
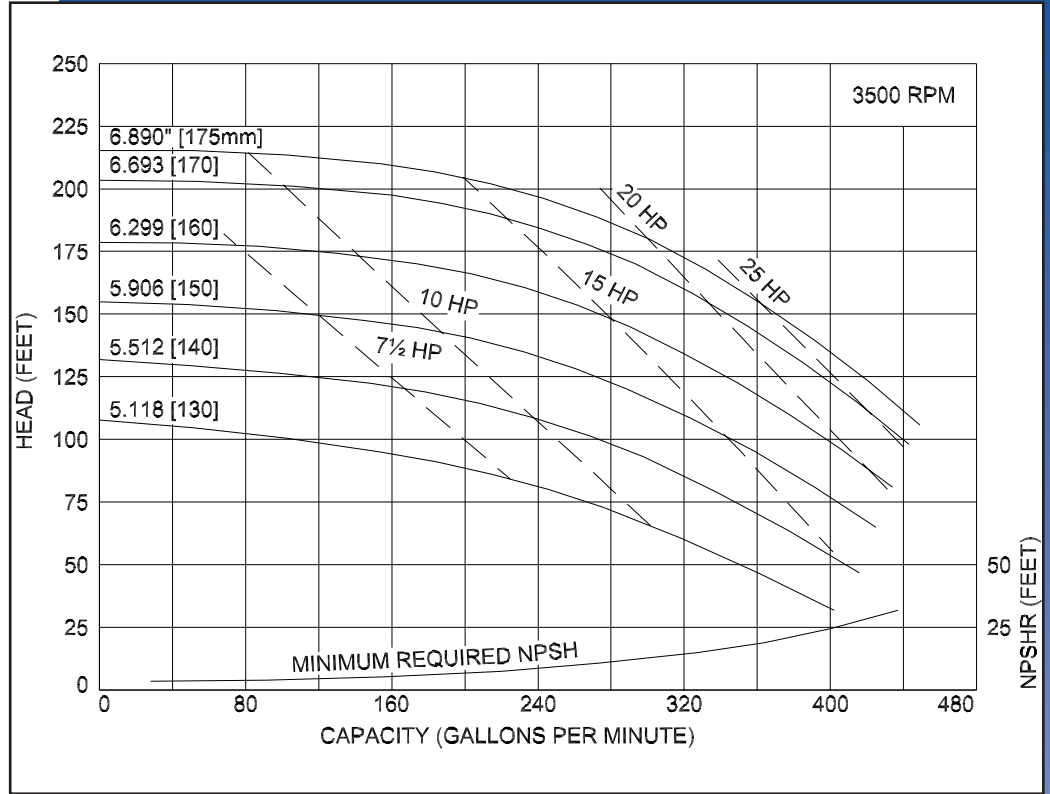

LD pumps are in conformance with 3A sanitary standards for centrifugal and positive rotary pumps for milk and milk products, Number 02-09.

LD-Series pumps have a standard 32RA (150 grit) finish, on all product contact surfaces.

**Ampco  
 Pumps  
 Company**



**CSI**  
 417.831.1411  
 csidesigns.com

# Ampco Centrifugal Pumps

## DATA SHEET

MODEL LD-V541 3X2 1/2  
MODEL LD-V542 3X2 1/2

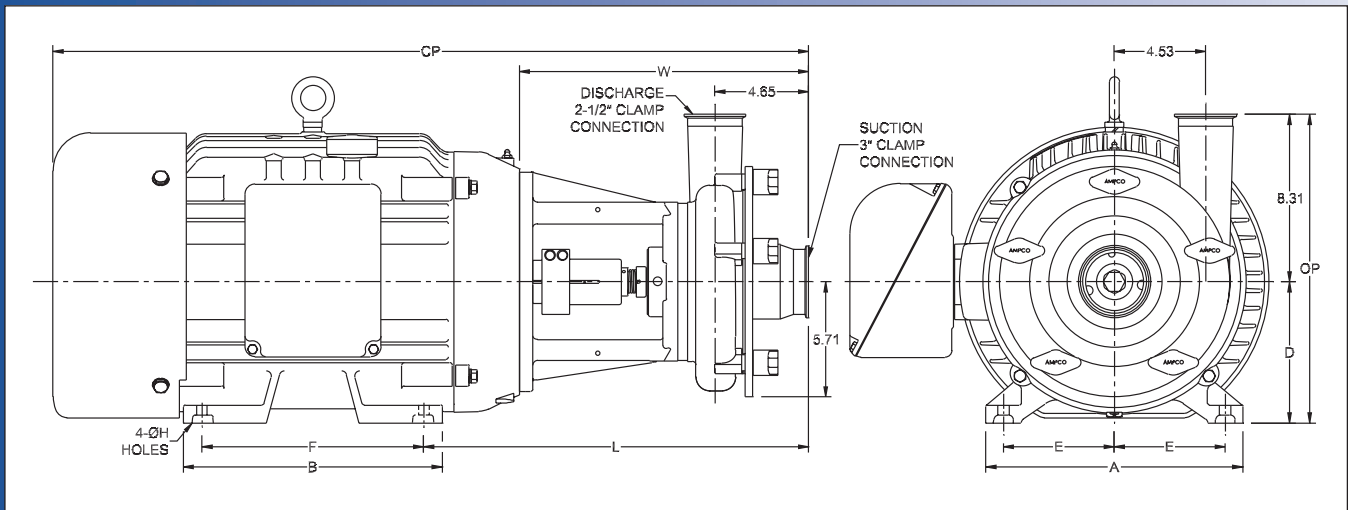
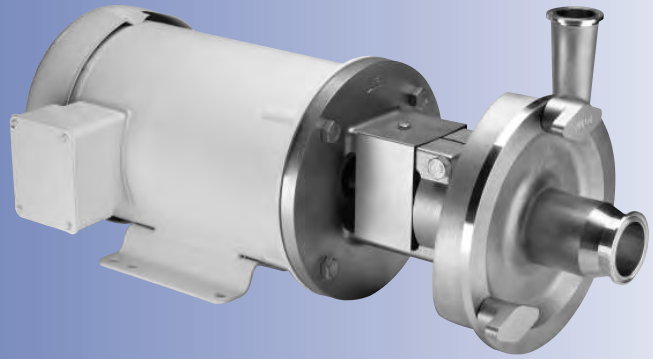

TEFC MOTOR			DIMENSIONS IN INCHES (For Reference Only)										APPROX WEIGHT (LBS)
HP	RPM	FRAME	A (typ)	B (typ)	D	E	F	ØH	L	W	CP	OP	
2	1750	145TC	6-1/2	6	3-1/2	2-3/4	5	11/32	16.92	14.17	25.23	11.81	117
3	1750	182TC	8-5/8	6-1/2	4-1/2	2-3/4	4-1/2	13/32	17.68	14.18	27.87	12.81	147
5	1750	184TC	8-5/8	6-1/2	4-1/2	3-3/4	5-1/2	13/32	17.68	14.18	29.36	12.81	154
7-1/2	1750	213TC	9-1/2	8	5-1/4	4-1/4	5-1/2	13/32	18.43	14.18	29.45	13.56	205
10	3500	215TC	9-1/2	8	5-1/4	4-1/4	7	13/32	18.43	14.18	29.45	13.56	201
15	3500	215TC	9-1/2	8	5-1/4	4-1/4	7	13/32	18.43	14.18	31.33	13.56	241
20	3500	256TC	11-1/2	11-1/2	6-1/4	5	10	17/32	19.10	14.35	35.48	14.56	368
25	3500	284TSC	12-3/4	12-3/4	7	5-1/2	9-1/2	17/32	19.10	14.35	37.48	15.31	461
30	3500	286TSC	12-3/4	12-3/4	7	5-1/2	11	17/32	19.10	14.35	37.48	15.31	483
40	3500	324TSC	14-1/2	14	8	6-1/4	10-1/2	21/32	20.23	14.98	39.98	16.31	597
50	3500	326TSC	14-1/2	14	8	6-1/4	12	21/32	20.23	14.98	39.98	16.31	706

### MATERIAL SPECIFICATIONS

PART NAME	STAINLESS STEEL
Casing, Cover & Impeller	316L Stainless
Stub Shaft	316L Stainless
Adapter	304 Stainless



**CSI**

417.831.1411  
csidesigns.com



MODEL LD-V541 3X2½  
 MODEL LD-V542 3X2½

# Ampco Centrifugal Pumps

Curves show approximate characteristics based on clear 68° water. Rated point is guaranteed.

LD-Series pumps have standard stainless steel adapters and silicon carbide vs. carbon internal seals and carbon vs. ceramic external seals.

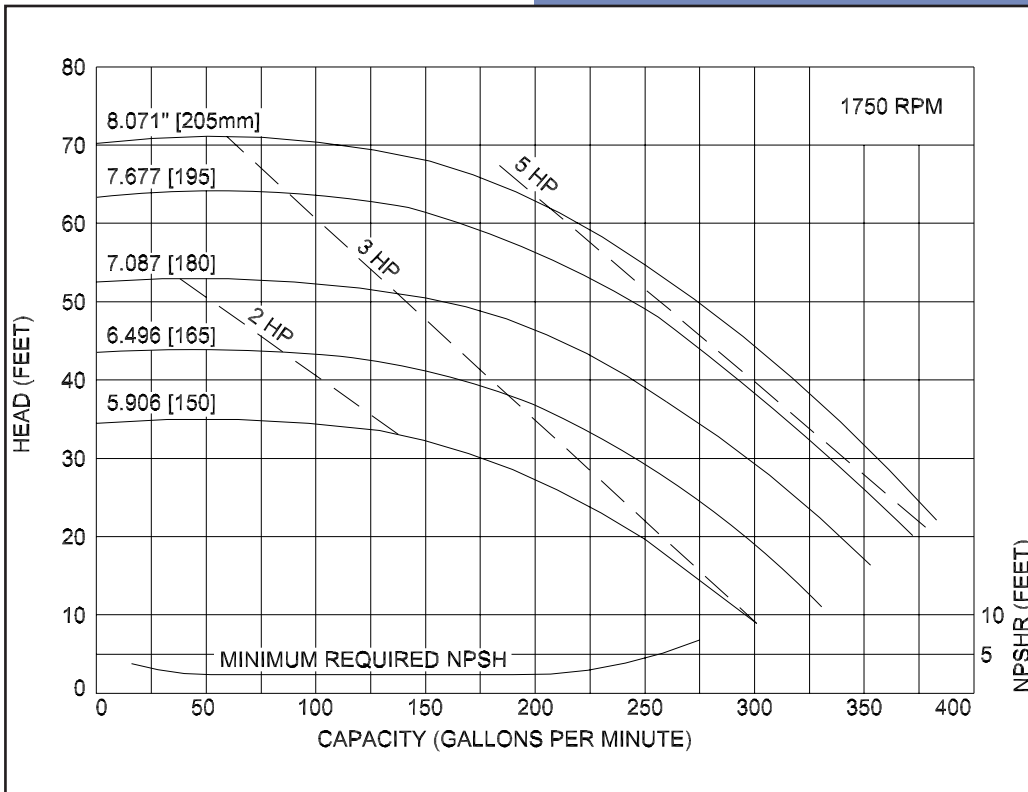
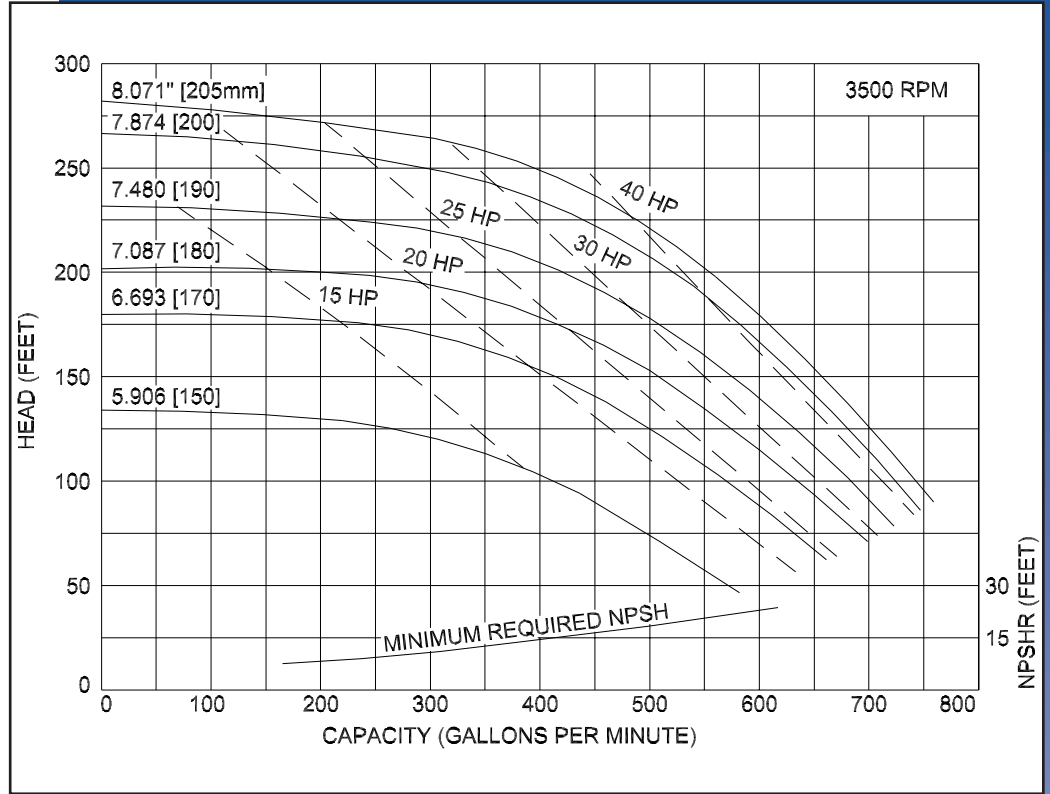

LD pumps are in conformance with 3A sanitary standards for centrifugal and positive rotary pumps for milk and milk products, Number 02-09.

LD-Series pumps have a standard 32RA (150 grit) finish, on all product contact surfaces.

**Ampco  
Pumps  
Company**



**CSI**  
 417.831.1411  
 csidesigns.com

# Ampco Centrifugal Pumps

## DATA SHEET

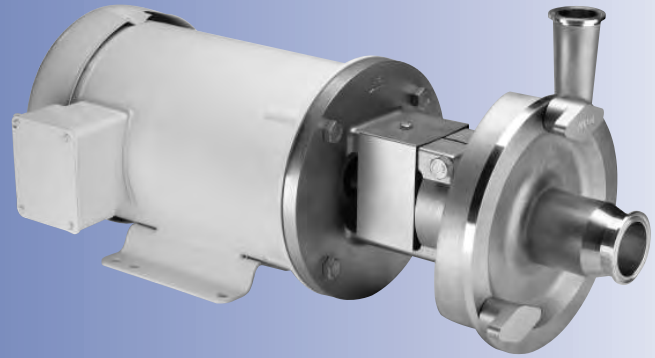

MODEL LD-V551 3X2 1/2  
MODEL LD-V552 3X2 1/2

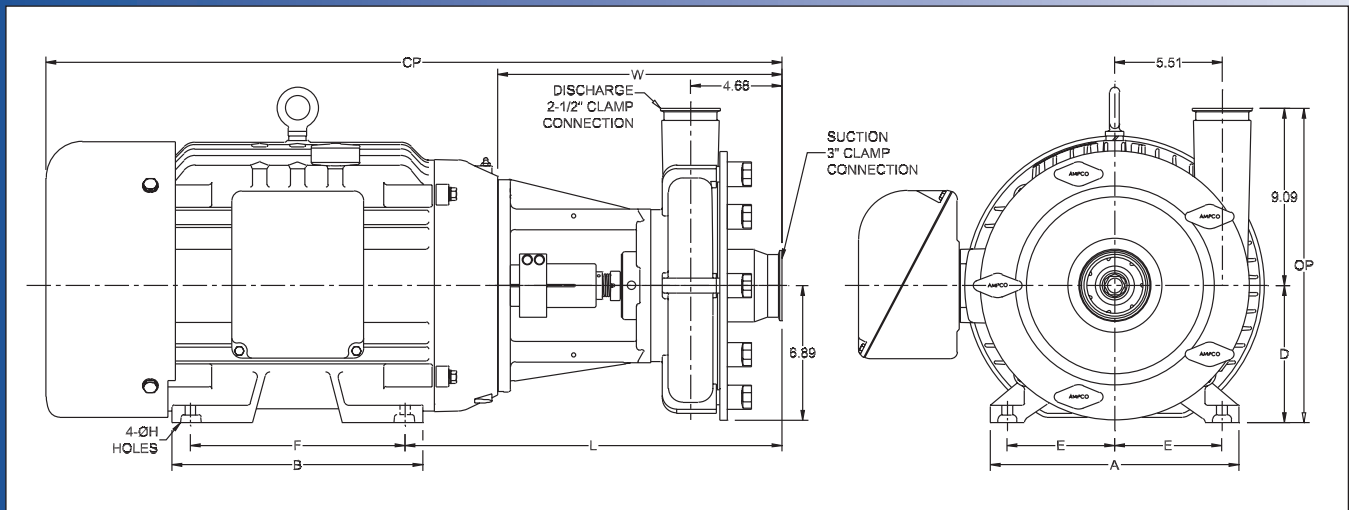

TEFC MOTOR			DIMENSIONS IN INCHES (For Reference Only)										APPROX WEIGHT (LBS)
HP	RPM	FRAME	A (typ)	B (typ)	D	E	F	ØH	L	W	CP	OP	
5	1750	184TC	8-5/8	6-1/2	4-1/2	3-3/4	5-1/2	13/32	18.08	14.58	30.07	13.59	199
7-1/2	1750	213TC	9-1/2	8	5-1/4	4-1/4	5-1/2	13/32	18.83	14.58	31.65	14.34	249
10	1750	215TC	9-1/2	8	5-1/4	4-1/4	7	13/32	18.83	14.58	32.78	15.17	259
15	1750	254TC	11-1/2	11-1/2	6-1/4	5	8-1/4	17/32	19.33	14.58	33.96	15.34	371
20	1750	256TC	11-1/2	11-1/2	6-1/4	5	10	17/32	19.33	14.58	36.05	15.34	394
25	3500	284TSC	12-3/4	12-3/4	7	5-1/2	9-1/2	17/32	19.33	14.58	37.71	16.09	483
30	3500	286TSC	12-3/4	12-3/4	7	5-1/2	11	17/32	19.33	14.58	37.71	16.09	505
40	3500	324TSC	14-1/2	14	8	6-1/4	10-1/2	21/32	20.46	15.21	40.21	17.09	619
50	3500	326TSC	14-1/2	14	8	6-1/4	12	21/32	20.46	15.21	40.21	17.09	728

## MATERIAL SPECIFICATIONS

PART NAME	STAINLESS STEEL
Casing, Cover & Impeller	316L Stainless
Stub Shaft	316L Stainless
Adapter	304 Stainless



**CSI**

417.831.1411  
csidesigns.com





MODEL LD-V551 3X2½  
 MODEL LD-V552 3X2½

# Ampco Centrifugal Pumps

Curves show approximate characteristics based on clear 68° water. Rated point is guaranteed.

LD-Series pumps have standard stainless steel adapters and silicon carbide vs. carbon internal seals and carbon vs. ceramic external seals.

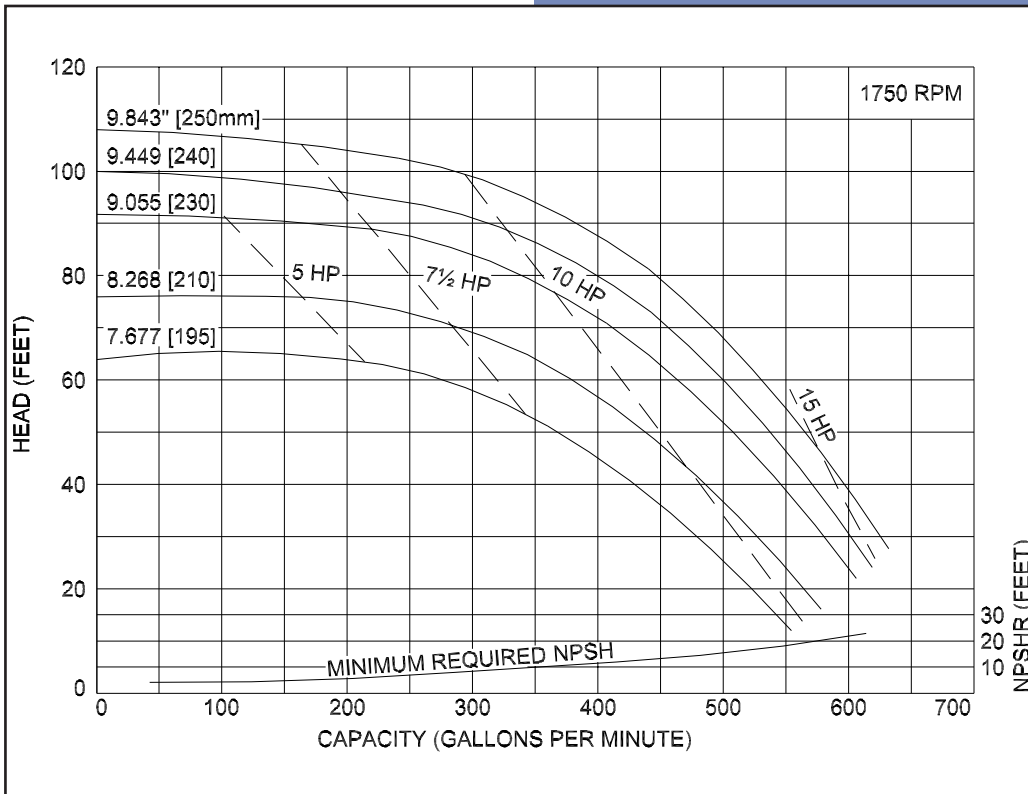
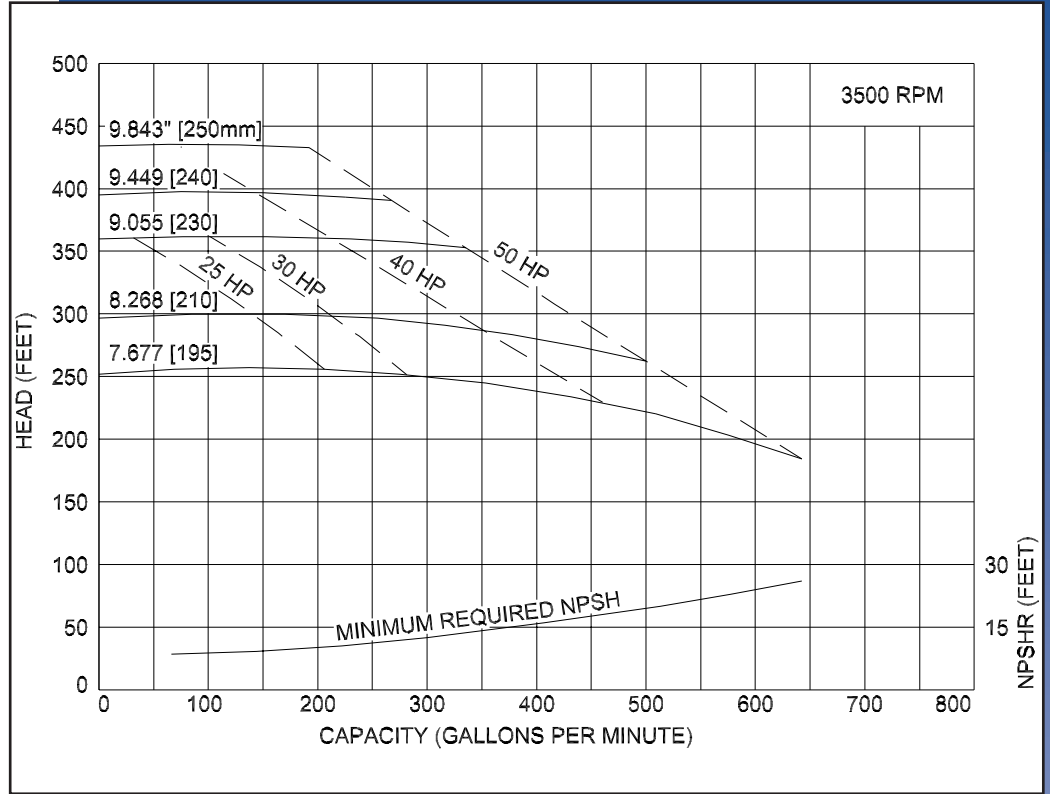

LD pumps are in conformance with 3A sanitary standards for centrifugal and positive rotary pumps for milk and milk products, Number 02-09.

LD-Series pumps have a standard 32RA (150 grit) finish, on all product contact surfaces.

**Ampco  
 Pumps  
 Company**



**CSI**  
 417.831.1411  
 csidesigns.com



# Ampco Centrifugal Pumps

DATA SHEET

MODEL LD-X051 4X4

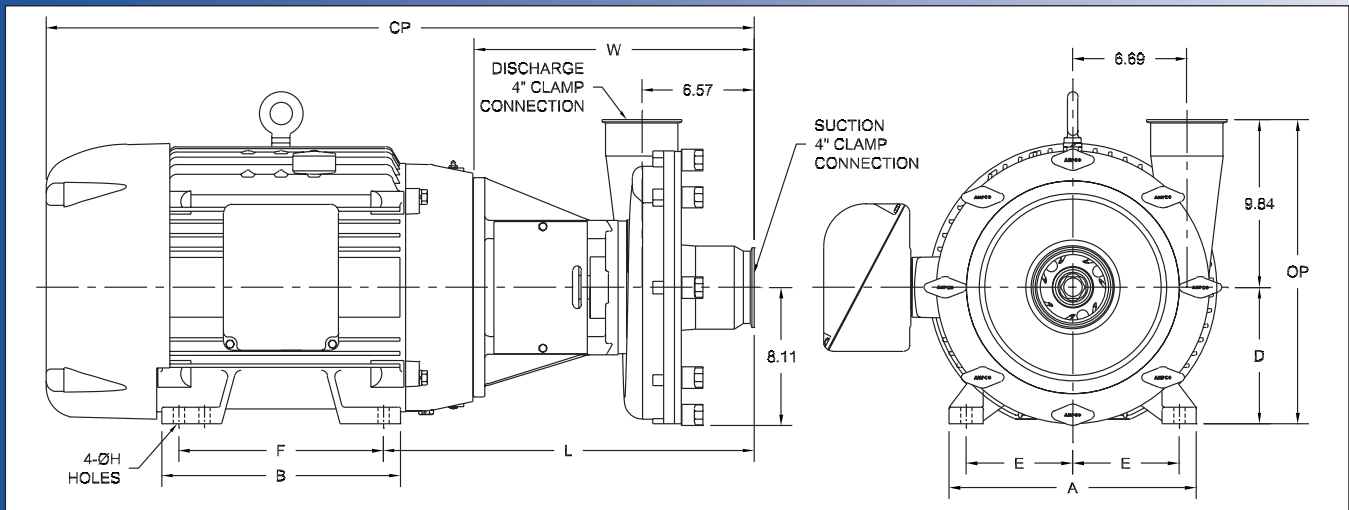
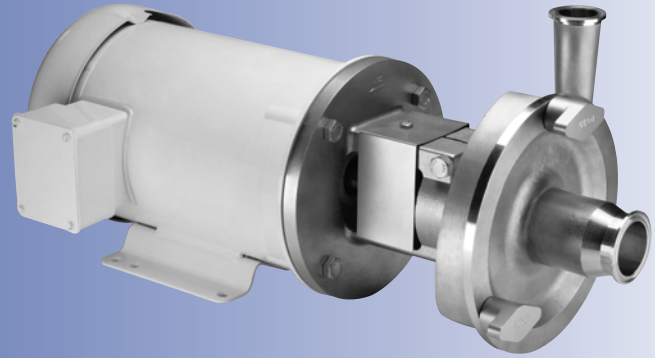

TEFC MOTOR			DIMENSIONS IN INCHES (For Reference Only)										APPROX WEIGHT (LBS)
HP	RPM	FRAME	A (typ)	B (typ)	D	E	F	ØH	L	W	CP	OP	
7-1/2	1750	213TC	9-1/2	8	5-1/4	4-1/4	5-1/2	13/32	20.09	15.84	31.10	15.09	300
10	1750	215TC	9-1/2	8	5-1/4	4-1/4	7	13/32	20.09	15.84	32.23	15.09	310
15	1750	254TC	11-1/2	11-1/2	6-1/4	5	8-1/4	17/32	20.59	15.84	33.41	16.09	424
20	1750	256TC	11-1/2	11-1/2	6-1/4	5	10	17/32	20.59	15.84	35.50	16.09	445
25	1750	284TC	12-3/4	12-3/4	7	5-1/2	9-1/2	17/32	20.59	15.84	37.18	16.84	578

## MATERIAL SPECIFICATIONS

PART NAME	STAINLESS STEEL
Casing, Cover & Impeller	316L Stainless
Stub Shaft	316L Stainless
Adapter	304 Stainless



**CSI**  
417.831.1411  
csidesigns.com



# Ampco Centrifugal Pumps

MODEL LD-X051 4X4

Curves show approximate characteristics based on clear 68° water.  
Rated point is guaranteed.

LD-Series pumps have standard stainless steel adapters and silicon carbide vs. carbon seals.

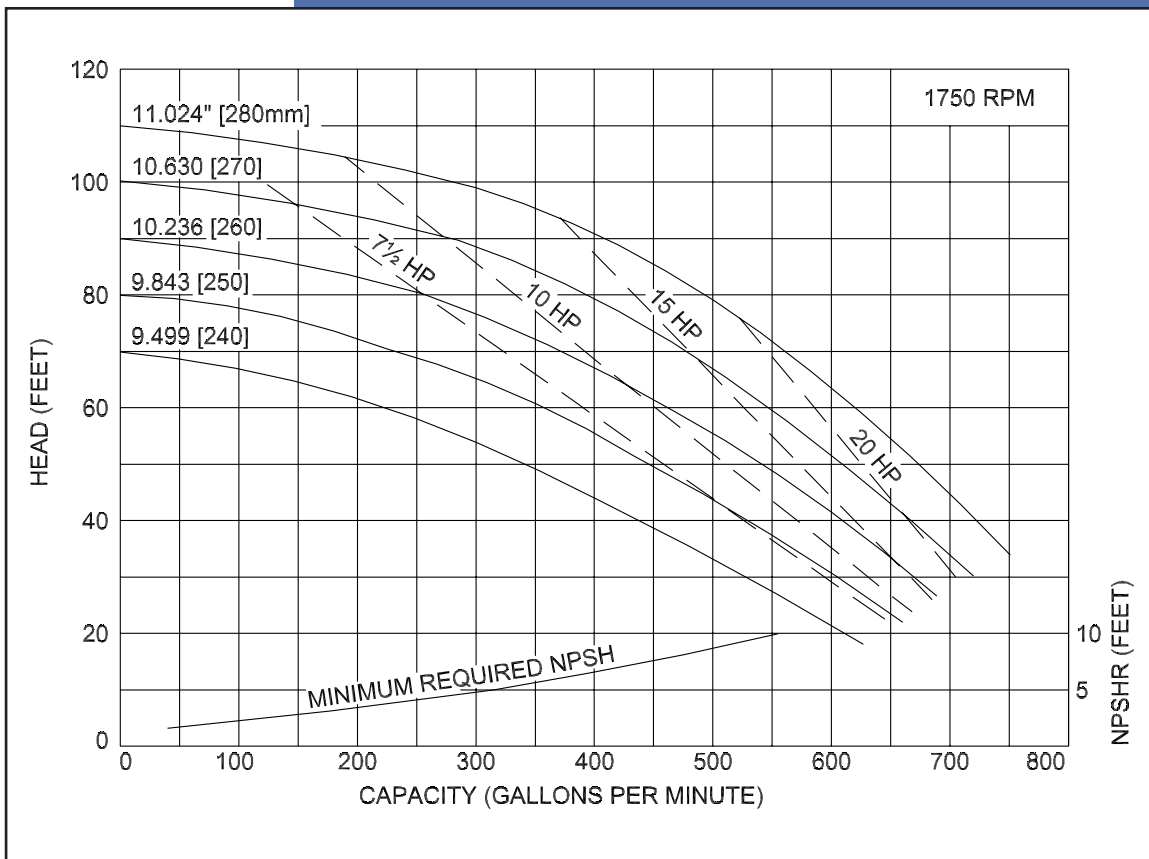

LD pumps are in conformance with 3A sanitary standards for centrifugal and positive rotary pumps for milk and milk products, Number 02-10.

LD-Series pumps have a standard 32RA (150 grit) finish, on all product contact surfaces.



**CSI** 417.831.1411 • [csidesigns.com](http://csidesigns.com)

LD-X051 4X4 01/07

# Ampco Centrifugal Pumps

DATA SHEET

MODEL LD-X151 4X4

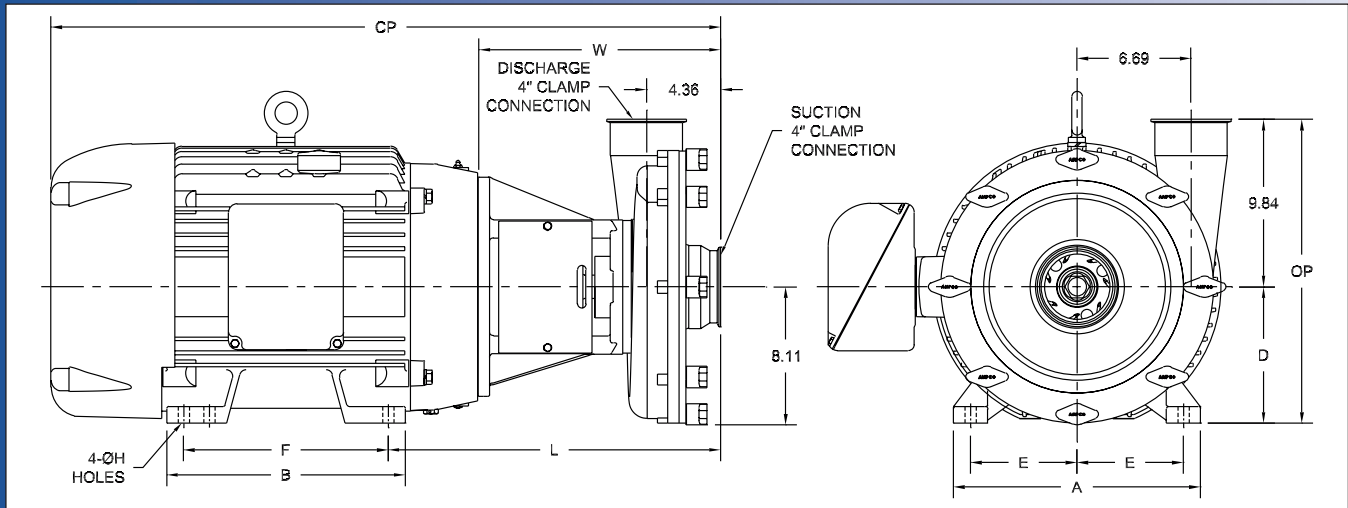
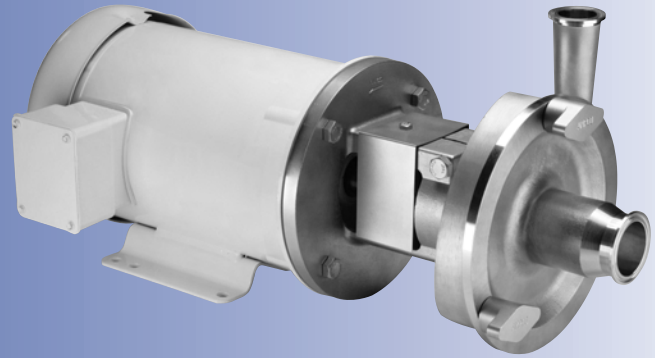

TEFC MOTOR			DIMENSIONS IN INCHES (For Reference Only)										APPROX WEIGHT (LBS)
HP	RPM	FRAME	A (typ)	B (typ)	D	E	F	ØH	L	W	CP	OP	
10	1750	215TC	9-1/2	8	5-1/4	4-1/4	7	11/32	17.87	13.62	30.01	15.09	310
15	1750	254TC	11-1/2	11-1/2	6-1/4	5	8-1/4	11/32	18.37	13.62	31.19	16.09	424
20	1750	256TC	11-1/2	11-1/2	6-1/4	5	10	13/32	18.37	13.62	33.28	16.09	445
25	1750	284TC	12-3/4	12-3/4	7	5-1/2	9-1/2	17/32	18.37	13.62	34.96	16.84	578
30	1750	286TC	12-3/4	12-3/4	7	5-1/2	11	17/32	18.37	13.62	34.96	16.84	589
40	1750	324TC	14-1/2	14	8	6-1/4	10-1/2	21/32	19.50	14.25	39.39	17.84	778

## MATERIAL SPECIFICATIONS

PART NAME	STAINLESS STEEL
Casing, Cover & Impeller	316L Stainless
Stub Shaft	316L Stainless
Adapter	304 Stainless



**CSI**  
417.831.1411  
csidesigns.com



# Ampco Centrifugal Pumps

MODEL LD-X151 4X4

Curves show approximate characteristics based on clear 68° water.  
Rated point is guaranteed.

LD-Series pumps have standard stainless steel adapters and silicon carbide vs. carbon seals.

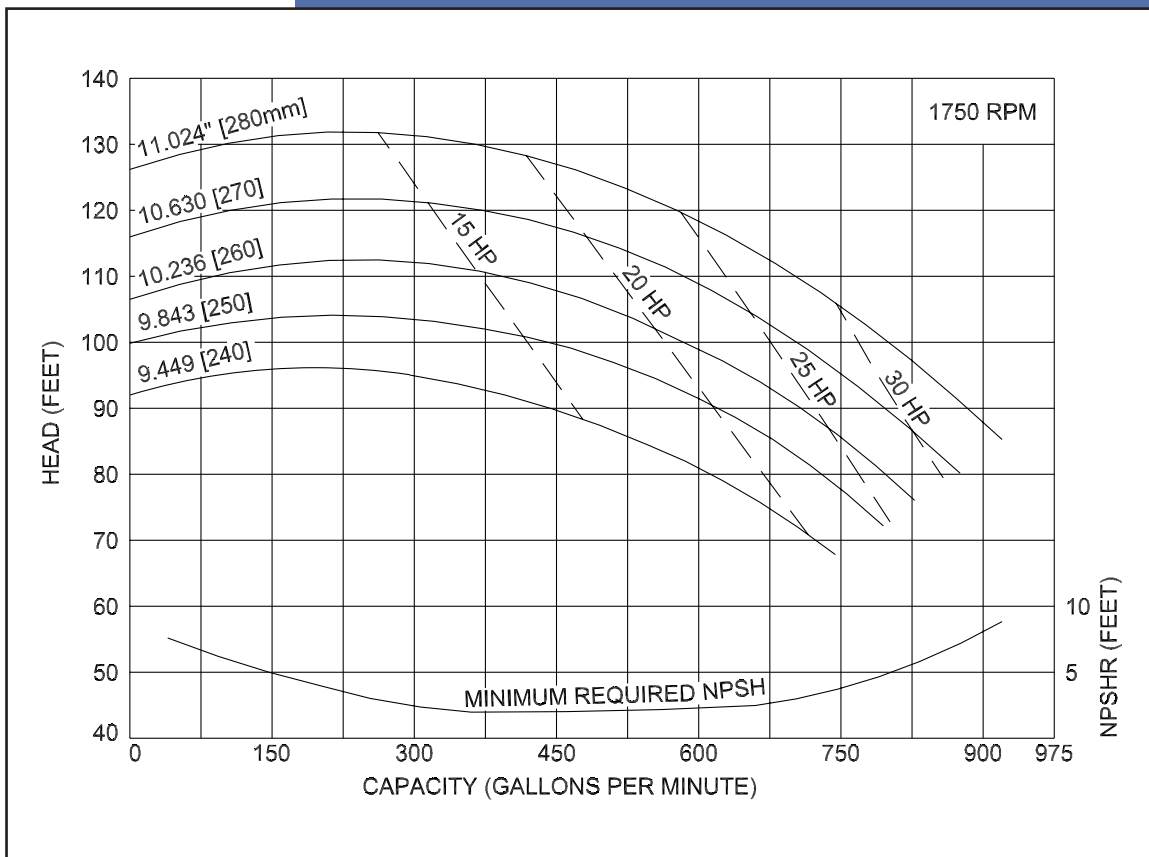

LD pumps are in conformance with 3A sanitary standards for centrifugal and positive rotary pumps for milk and milk products, Number 02-10.

LD-Series pumps have a standard 32RA (150 grit) finish, on all product contact surfaces.



**CSI**

417.831.1411 • [csidesigns.com](http://csidesigns.com)

# Ampco Centrifugal Pumps

DATA SHEET

MODEL LD-X161 4X4

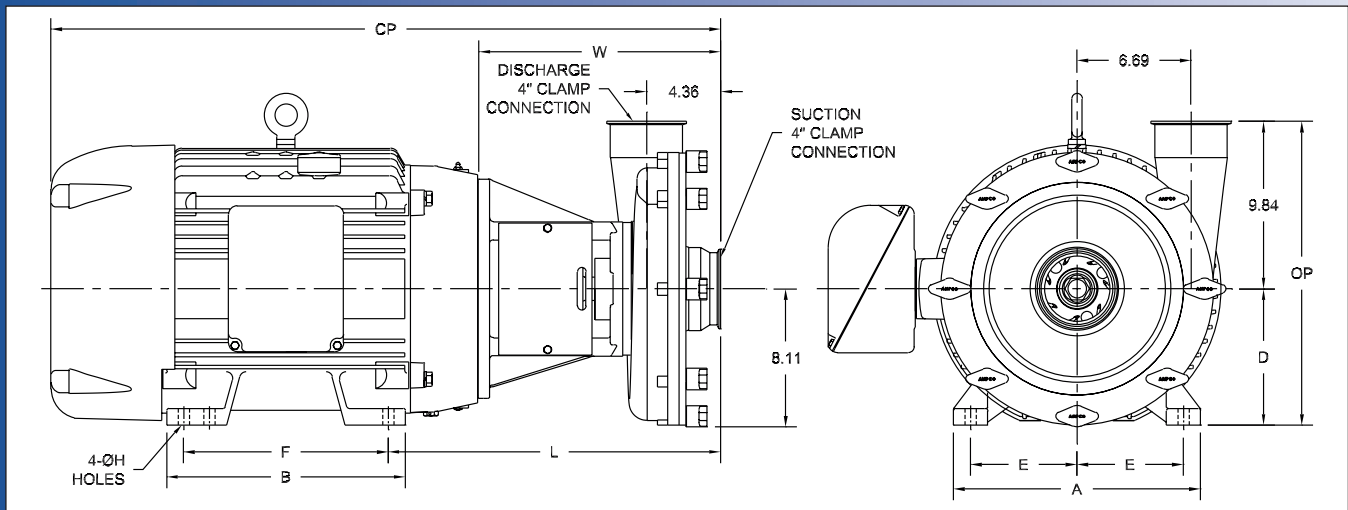
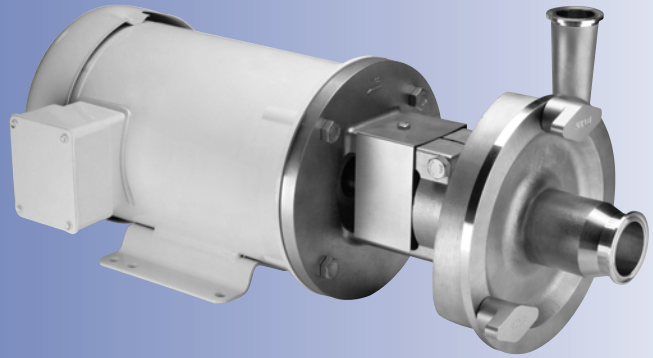

TEFC MOTOR			DIMENSIONS IN INCHES (For Reference Only)										APPROX WEIGHT (LBS)
HP	RPM	FRAME	A (typ)	B (typ)	D	E	F	ØH	L	W	CP	OP	
15	1750	254TC	11-1/2	11-1/2	6-1/4	5	8-1/4	11/32	18.37	13.62	31.19	16.09	426
20	1750	256TC	11-1/2	11-1/2	6-1/4	5	10	13/32	18.37	13.62	33.28	16.09	447
25	1750	284TC	12-3/4	12-3/4	7	5-1/2	9-1/2	17/32	18.37	13.62	34.96	16.84	580
30	1750	286TC	12-3/4	12-3/4	7	5-1/2	11	17/32	18.37	13.62	34.96	16.84	591
40	1750	324TC	14-1/2	14	8	6-1/4	10-1/2	21/32	19.50	14.25	39.39	17.84	780
50	1750	326TC	14-1/2	14	8	6-1/4	12	21/32	19.50	14.25	39.39	17.84	765

## MATERIAL SPECIFICATIONS

PART NAME	STAINLESS STEEL
Casing, Cover & Impeller	316L Stainless
Stub Shaft	316L Stainless
Adapter	304 Stainless



**CSI**  
417.831.1411  
csidesigns.com



# Ampco Centrifugal Pumps

MODEL LD-X161 4X4

Curves show approximate characteristics based on clear 68° water.  
Rated point is guaranteed.

LD-Series pumps have standard stainless steel adapters and silicon carbide vs. carbon seals.

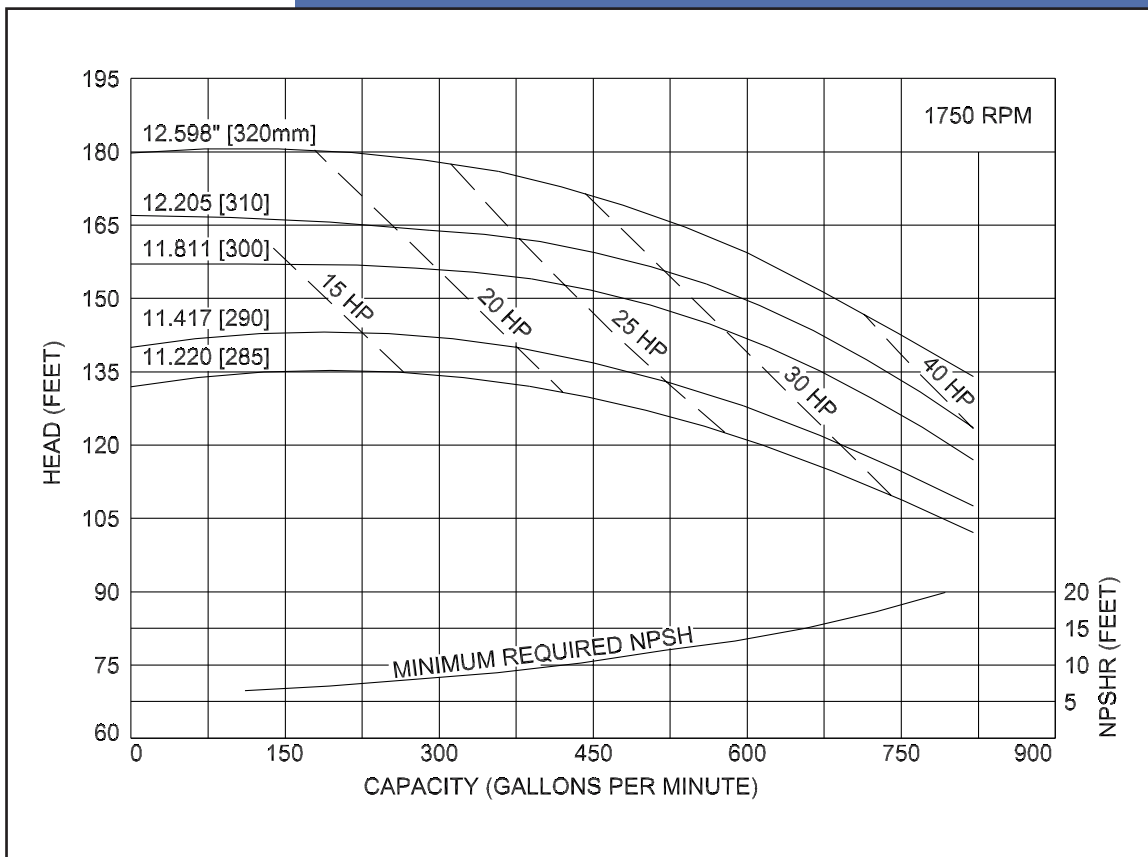

LD pumps are in conformance with 3A sanitary standards for centrifugal and positive rotary pumps for milk and milk products, Number 02-10.

LD-Series pumps have a standard 32RA (150 grit) finish, on all product contact surfaces.



**CSI**

417.831.1411  
csidesigns.com