

Ampco Centrifugal Pumps

DATA SHEET

Model CB+ 114 1½ x 1 ½

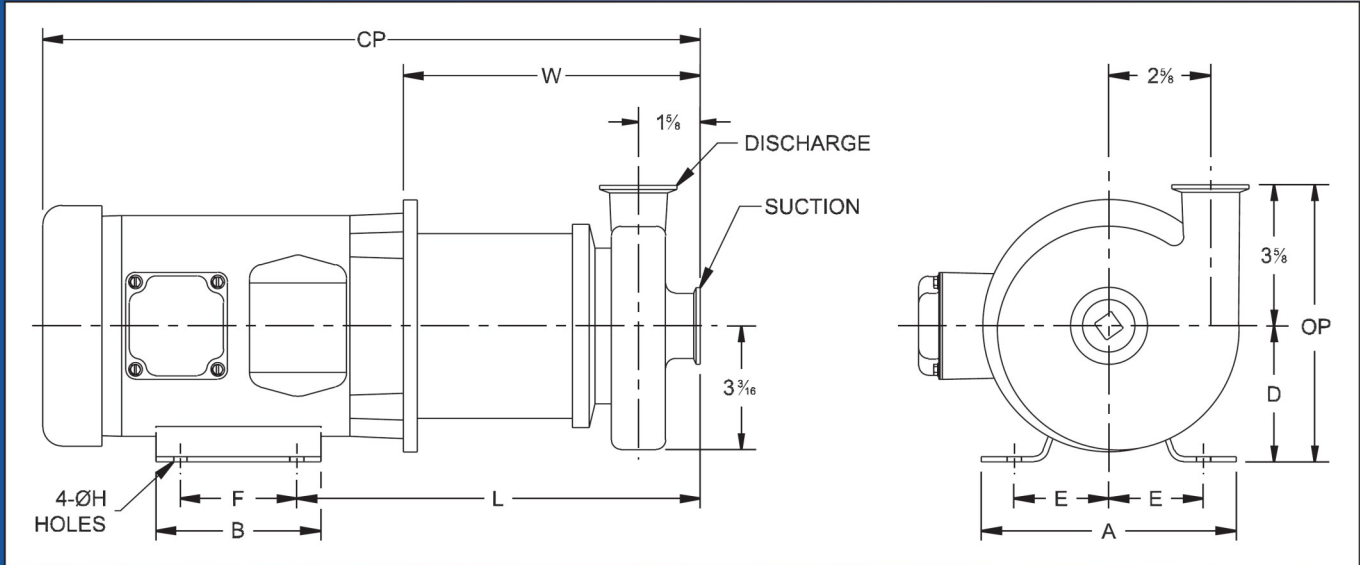
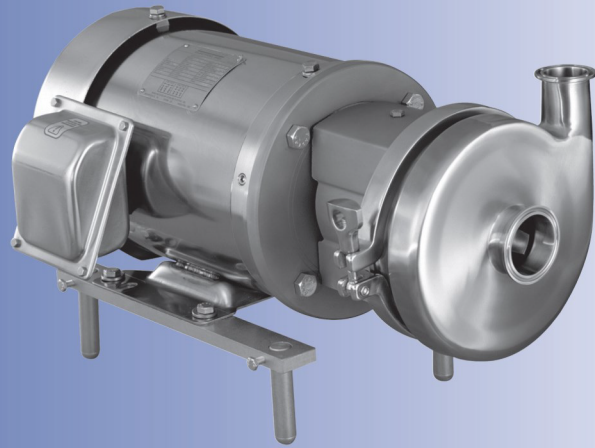

TEFC MOTOR			DIMENSIONS IN INCHES (For Reference Only)										APPROX WEIGHT (LBS)
HP	RPM	FRAME	A (typ)	B (typ)	D	E	F	ØH	L	W	CP	OP	
1/4	1750	56C	6-9/16	4-1/4	3-1/2	2-7/16	3	7/16	10-7/16	7-11/16	16-15/16	7-1/8	20
1/2	1750	56C	6-9/16	4-1/4	3-1/2	2-7/16	3	7/16	10-7/16	7-11/16	16-15/16	7-1/8	35
1/2	3500	56C	6-9/16	4-1/4	3-1/2	2-7/16	3	7/16	10-7/16	7-11/16	16-15/16	7-1/8	36
3/4	3500	56C	6-9/16	4-1/4	3-1/2	2-7/16	3	7/16	10-7/16	7-11/16	16-15/16	7-1/8	42
1	3500	56C	6-9/16	4-1/4	3-1/2	2-7/16	3	7/16	10-7/16	7-11/16	16-15/16	7-1/8	44
1-1/2	3500	56C	6-9/16	4-1/4	3-1/2	2-7/16	3	7/16	10-7/16	7-11/16	17-15/16	7-1/8	59
1-1/2	3500	143TC	6-1/2	6	3-1/2	2-3/4	5	11/32	10-7/16	7-11/16	18-15/16	7-1/8	59
2	3500	56C	6-9/16	4-1/4	3-1/2	2-7/16	3	7/16	10-7/16	7-11/16	17-15/16	7-1/8	73
2	3500	145TC	6-1/2	6	3-1/2	2-3/4	5	11/32	10-7/16	7-11/16	18-15/16	7-1/8	66
3	3500	145TC	6-1/2	6	3-1/2	2-3/4	5	11/32	10-7/16	7-11/16	18-15/16	7-1/8	75
5	3500	184TC	8-5/8	6-1/2	4-1/12	3-3/4	5-1/2	13/32	11-13/16	8-5/16	23-7/16	8-1/8	98

MATERIAL SPECIFICATIONS

PART NAME	STAINLESS STEEL
Casing	316L Stainless
Backplate, Impeller, Stub Shaft	316L Stainless
Adapter	304 Stainless

Ampco Centrifugal Pumps

Model CB+ 114 1½ x 1½

Curves show approximate characteristics
based on clear 68° water.
Rated point is guaranteed.

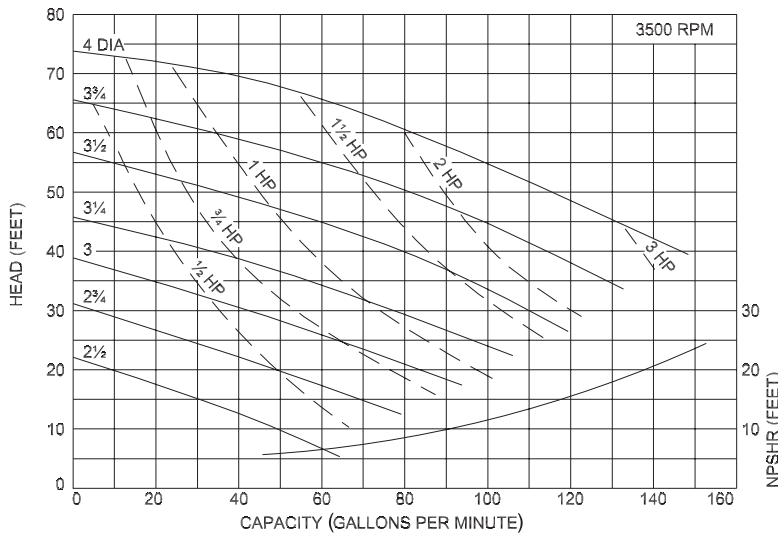

CB+ Series pumps have standard stainless steel adapters and utilize an internal seal.

CB+ Series pumps have a standard 32RA (150 grit) finish, on all product contact surfaces.

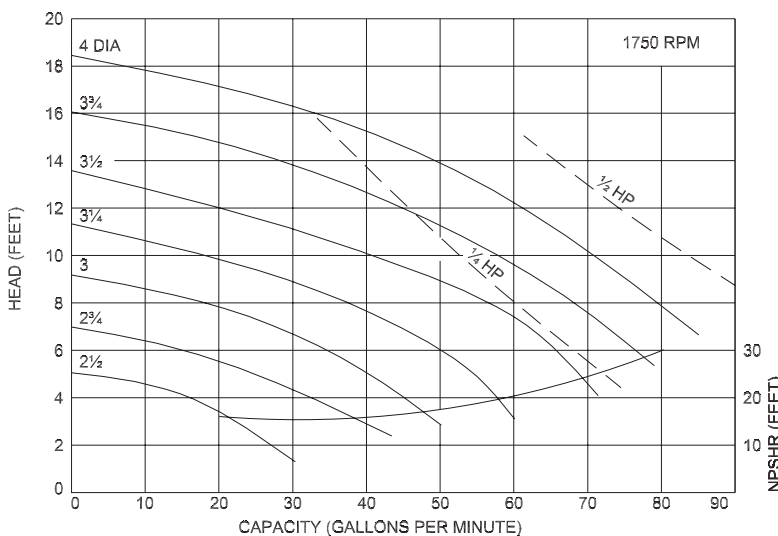
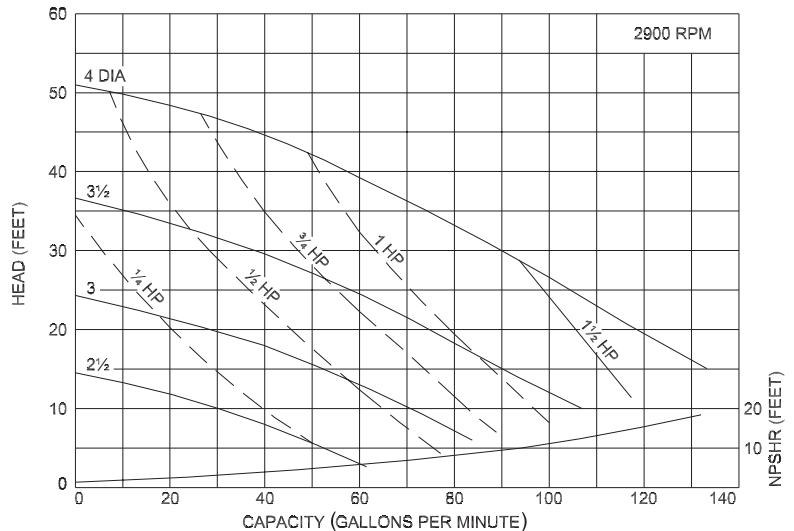

Ampco Pumps Company

2045 West Mill Road
Glendale, Wisconsin 53209
PHONE (414) 643-1852
FAX (414) 643-4452

Ampco Centrifugal Pumps

DATA SHEET

Model CB+ 214 2x1½

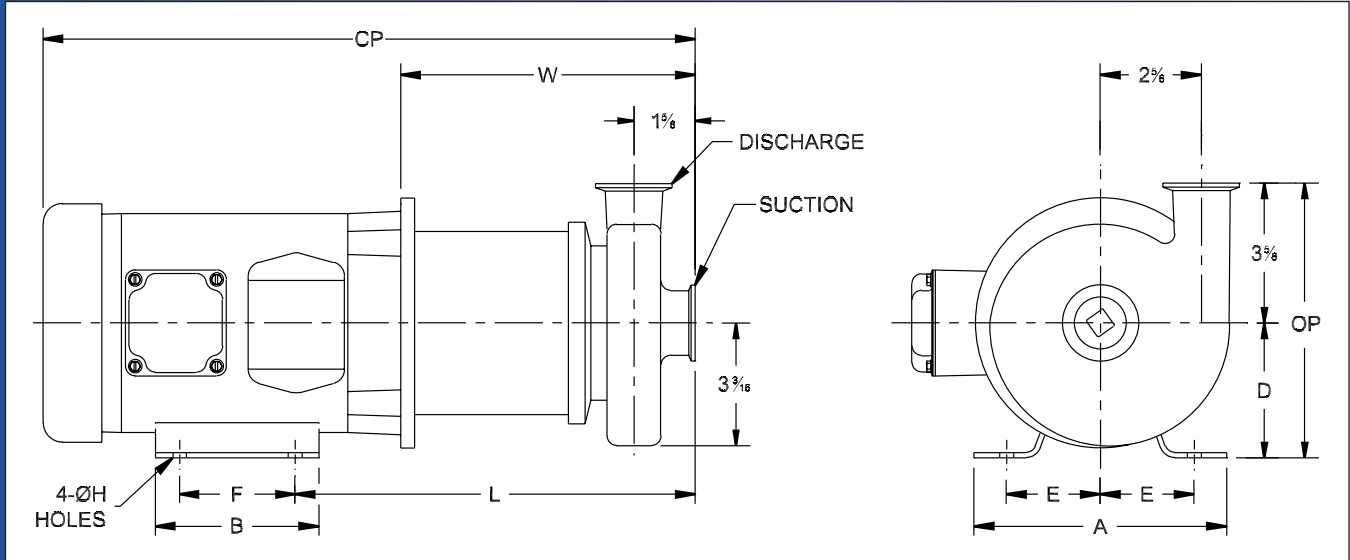
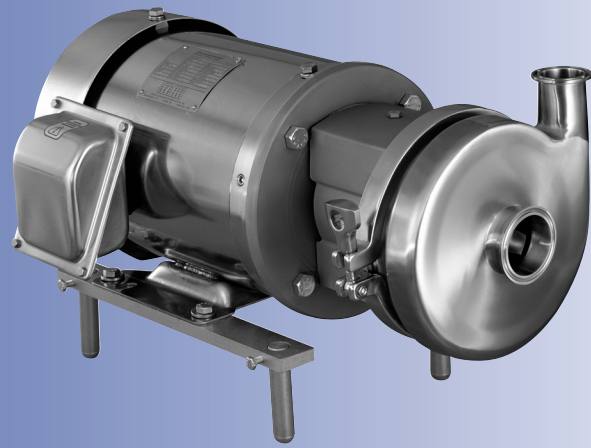

TEFC MOTOR			DIMENSIONS IN INCHES (For Reference Only)										APPROX WEIGHT (LBS)
HP	RPM	FRAME	A (typ)	B (typ)	D	E	F	ØH	L	W	CP	OP	
1/4	1750	56C	6-9/16	4-1/4	3-1/2	2-7/16	3	7/16	10-7/16	7-11/16	16-15/16	7-1/8	20
1/2	1750	56C	6-9/16	4-1/4	3-1/2	2-7/16	3	7/16	10-7/16	7-11/16	16-15/16	7-1/8	20
1/2	1750	56C	6-9/16	4-1/4	3-1/2	2-7/16	3	7/16	10-7/16	7-11/16	16-15/16	7-1/8	41
3/4	3500	56C	6-9/16	4-1/4	3-1/2	2-7/16	3	7/16	10-7/16	7-11/16	16-15/16	7-1/8	42
1	3500	56C	6-9/16	4-1/4	3-1/2	2-7/16	3	7/16	10-7/16	7-11/16	16-15/16	7-1/8	44
1-1/2	3500	56C	6-9/16	4-1/4	3-1/2	2-7/16	3	7/16	10-7/16	7-11/16	17-15/16	7-1/8	59
1-1/2	3500	143TC	6-1/2	6	3-1/2	2-3/4	5	11/32	10-7/16	7-11/16	18-15/16	7-1/8	59
2	3500	56C	6-9/16	4-1/4	3-1/2	2-7/16	3	7/16	10-7/16	7-11/16	17-15/16	7-1/8	73
2	3500	145TC	6-1/2	6	3-1/2	2-3/4	5	11/32	10-7/16	7-11/16	18-15/16	7-1/8	66
3	3500	145TC	6-1/2	6	3-1/2	2-3/4	5	11/32	10-7/16	7-11/16	18-15/16	7-1/8	75
5	3500	184TC	8-5/8	6-1/2	4-1/2	3-3/4	5-1/2	13/32	11-13/16	8-5/16	23-7/16	8-1/8	98

MATERIAL SPECIFICATIONS

PART NAME	STAINLESS STEEL
Casing	316L Stainless
Backplate, Impeller, Stub Shaft	316L Stainless
Adapter	304 Stainless

Ampco Centrifugal Pumps

Model CB+ 214 2 x 1½

Curves show approximate characteristics
based on clear 68° water.
Rated point is guaranteed.

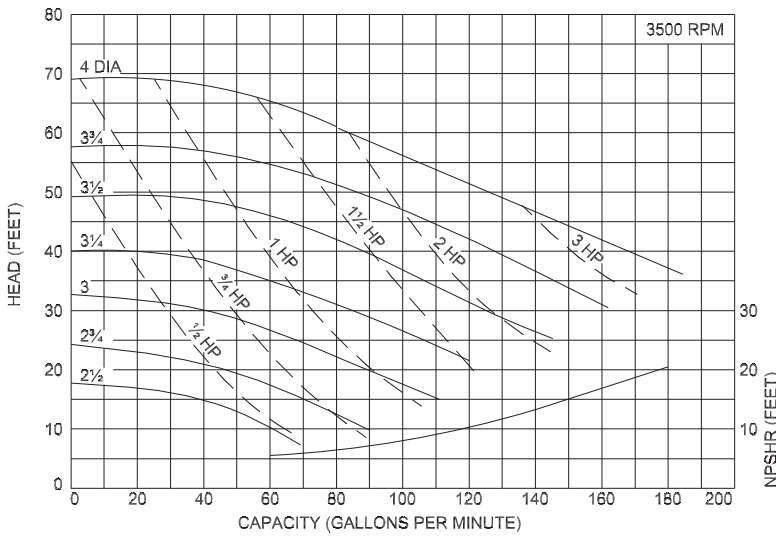

CB+ Series pumps have standard stainless steel adapters and utilize an internal seal.

CB+ Series pumps have a standard 32RA (150 grit) finish, on all product contact surfaces.

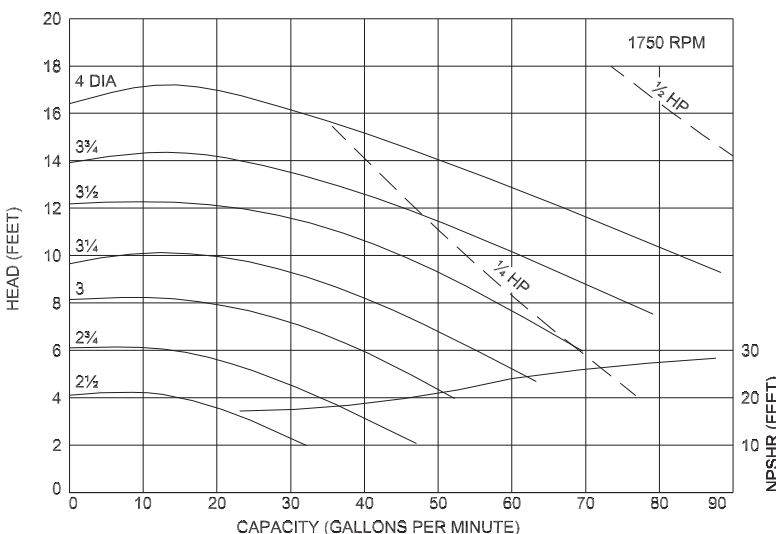
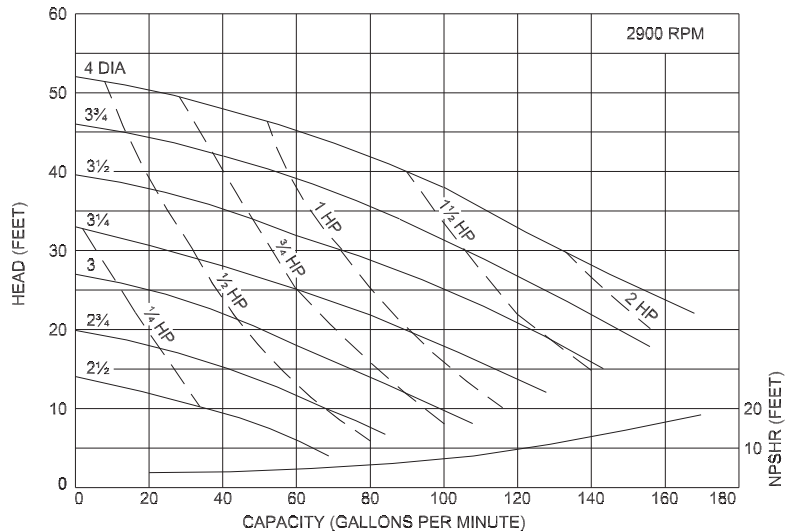

Ampco Pumps Company

2045 West Mill Road
Glendale, Wisconsin 53209
PHONE (414) 643-1852
FAX (414) 643-4452

Ampco Centrifugal Pumps

DATA SHEET

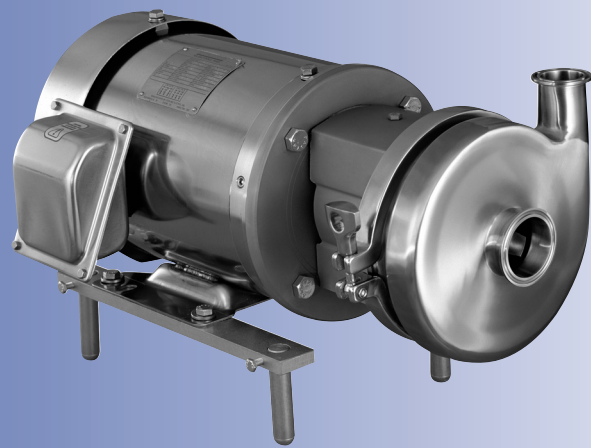

Model CB+ 216 2 x 1½

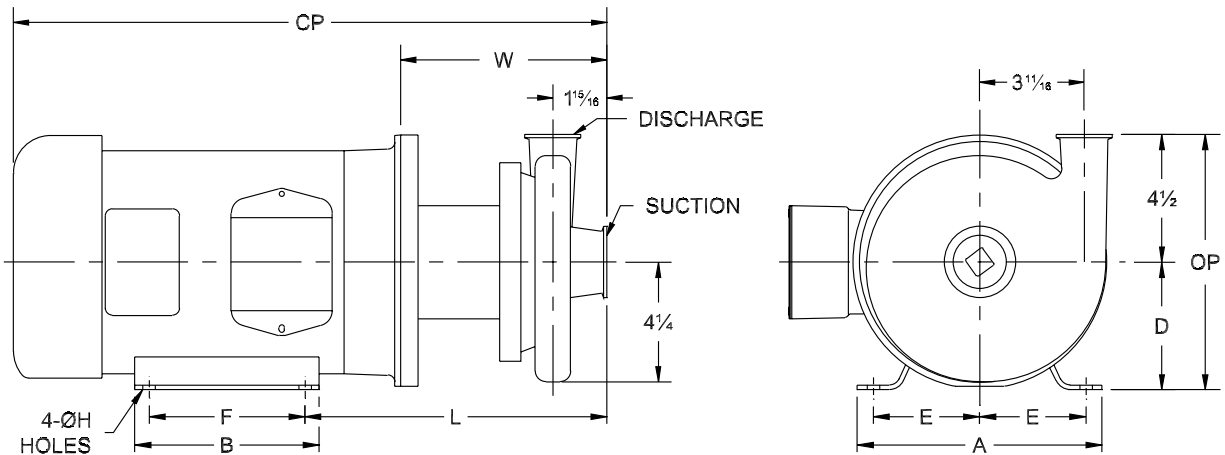

TEFC MOTOR			DIMENSIONS IN INCHES (For Reference Only)										APPROX WEIGHT (LBS)
HP	RPM	FRAME	A (typ)	B (typ)	D	E	F	ØH	L	W	CP	OP	
1/2	1750	56C	6-9/16	4-1/4	3-1/2	2-7/16	3	7/16	10-11/16	7-15/16	17-3/16	8	49
3/4	1750	56C	6-9/16	4-1/4	3-1/2	2-7/16	3	7/16	10-11/16	7-15/16	17-3/16	8	53
1	1750	56C	6-9/16	4-1/4	3-1/2	2-7/16	3	7/16	10-11/16	7-15/16	17-3/16	8	58
1-1/2	1750	56C	6-9/16	4-1/4	3-1/2	2-7/16	3	7/16	10-11/16	7-15/16	17-3/16	8	62
1-1/2	1750	145TC	6-1/2	6	3-1/2	2-3/4	5	11/32	10-11/16	7-15/16	19-3/16	8	72
2	1750	145TC	6-1/2	6	3-1/2	2-3/4	5	11/32	10-11/16	7-15/16	19-3/16	8	75
3	1750	182TC	8-5/8	6-1/2	4-1/2	3-3/4	4-1/2	13/32	12-1/16	8-9/16	22-5/16	9	104
3	3500	145TC	6-1/2	6	3-1/2	2-3/4	5	11/32	10-11/16	7-15/16	19-3/16	8	83
5	3500	184TC	8-5/8	6-1/2	4-1/2	3-3/4	5-1/2	13/32	12-1/16	8-9/16	23-11/16	9	106
7-1/2	3500	184TC	8-5/8	6-1/2	4-1/2	3-3/4	5-1/2	13/32	12-15/16	8-9/16	23-11/16	9	124
7-1/2	3500	213TC	9-1/2	8	5-1/4	4-1/4	5-1/2	13/32	13-15/16	9-11/16	24-15/16	9-3/4	128
10	3500	215TC	9-1/2	8	5-1/4	4-1/4	7	13/32	13-15/16	9-11/16	26-11/16	9-3/4	161
15	3500	215TC	9-1/2	8	5-1/4	4-1/4	7	13/32	13-15/16	9-11/16	26-11/16	9-3/4	201
20	3500	256TC	11-1/2	11-1/2	6-1/4	5	10	17/32	15-1/16	10-5/16	30-1/16	10-3/4	308

MATERIAL SPECIFICATIONS

PART NAME	STAINLESS STEEL
Casing	316L Stainless
Backplate, Impeller, Stub Shaft	316L Stainless
Adapter	304 Stainless

Ampco Centrifugal Pumps

Model CB+ 216 2 x 1½

Curves show approximate characteristics
based on clear 68° water.
Rated point is guaranteed.

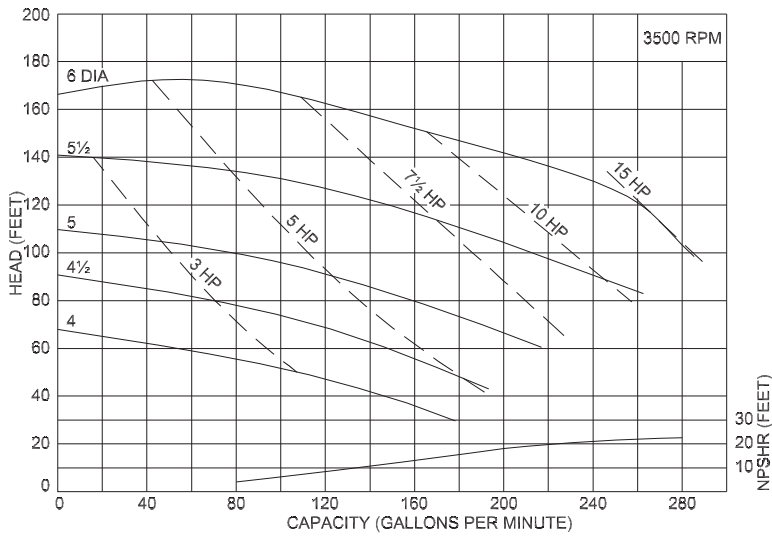

CB+ Series pumps have standard stainless steel adapters and utilize an internal seal.

CB+ Series pumps have a standard 32RA (150 grit) finish, on all product contact surfaces.

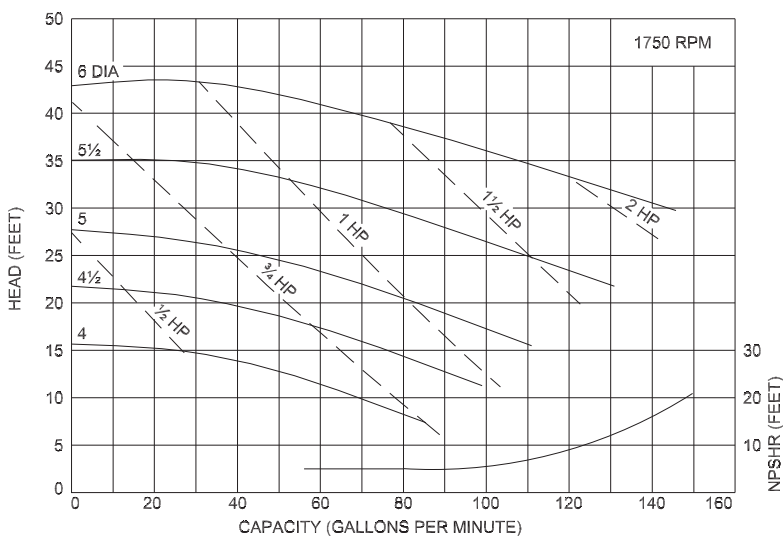
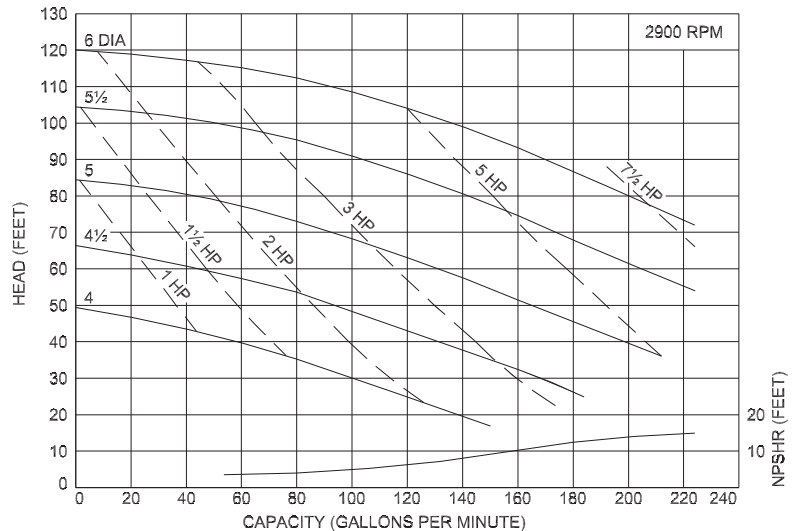

Ampco Pumps Company

2045 West Mill Road
Glendale, Wisconsin 53209
PHONE (414) 643-1852
FAX (414) 643-4452

Ampco Centrifugal Pumps

DATA SHEET

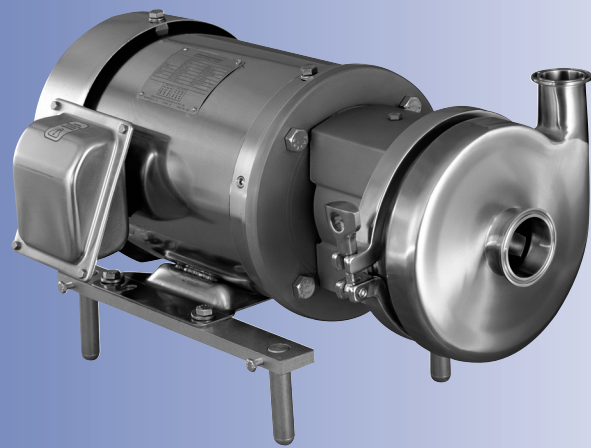

Model CB+ 316 2½ x 1½

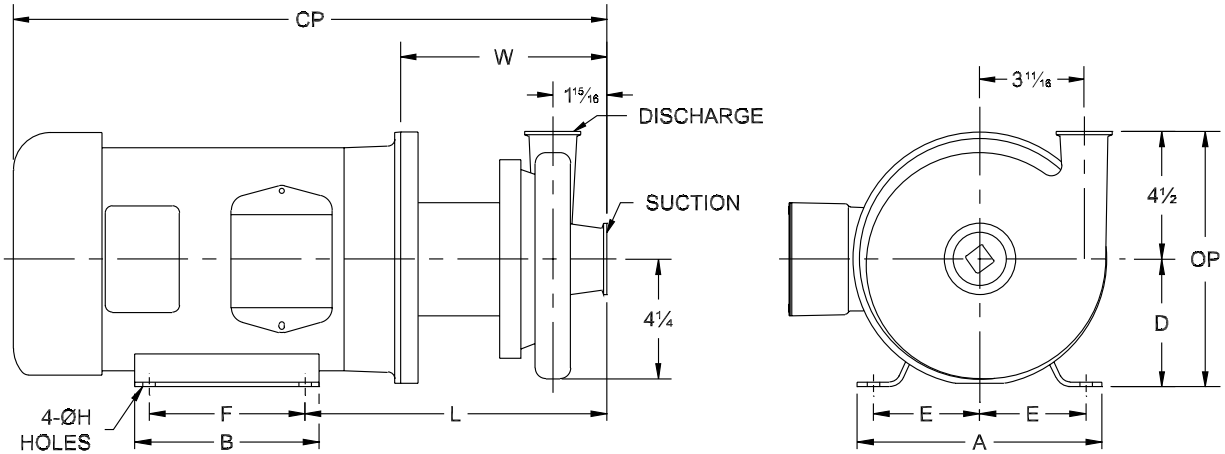

TEFC MOTOR			DIMENSIONS IN INCHES (For Reference Only)										APPROX WEIGHT (LBS)
HP	RPM	FRAME	A (typ)	B (typ)	D	E	F	ØH	L	W	CP	OP	
1/2	1750	56C	6-9/16	4-1/4	3-1/2	2-7/16	3	7/16	10-11/16	7-15/16	17-3/16	8	49
3/4	1750	56C	6-9/16	4-1/4	3-1/2	2-7/16	3	7/16	10-11/16	7-15/16	17-3/16	8	53
1	1750	56C	6-9/16	4-1/4	3-1/2	2-7/16	3	7/16	10-11/16	7-15/16	17-3/16	8	58
1-1/2	1750	56C	6-9/16	4-1/4	3-1/2	2-7/16	3	7/16	10-11/16	7-15/16	17-3/16	8	62
1-1/2	1750	145TC	6-1/2	6	3-1/2	2-3/4	5	11/32	10-11/16	7-15/16	19-3/16	8	72
2	1750	145TC	6-1/2	6	3-1/2	2-3/4	5	11/32	10-11/16	7-15/16	19-3/16	8	75
3	1750	182TC	8-5/8	6-1/2	4-1/2	3-3/4	4-1/2	13/32	12-1/16	8-9/16	22-5/16	9	104
3	3500	145TC	6-1/2	6	3-1/2	2-3/4	5	11/32	10-11/16	7-15/16	19-3/16	8	83
5	3500	184TC	8-5/8	6-1/2	4-1/2	3-3/4	5-1/2	13/32	12-1/16	8-9/16	23-11/16	9	106
7-1/2	3500	184TC	8-5/8	6-1/2	4-1/2	3-3/4	5-1/2	13/32	12-15/16	8-9/16	23-11/16	9	124
7-1/2	3500	213TC	9-1/2	8	5-1/4	4-1/4	5-1/2	13/32	13-15/16	9-11/16	24-15/16	9-3/4	128
10	3500	215TC	9-1/2	8	5-1/4	4-1/4	7	13/32	13-15/16	9-11/16	26-11/16	9-3/4	161
15	3500	215TC	9-1/2	8	5-1/4	4-1/4	7	13/32	13-15/16	9-11/16	26-11/16	9-3/4	201
20	3500	256TC	11-1/2	11-1/2	6-1/4	5	10	17/32	15-1/16	10-5/16	30-1/16	10-3/4	308

MATERIAL SPECIFICATIONS

PART NAME	STAINLESS STEEL
Casing	316L Stainless
Backplate, Impeller, Stub Shaft	316L Stainless
Adapter	304 Stainless

Ampco Centrifugal Pumps

Model CB+ 316 2½ x1½

Curves show approximate characteristics
based on clear 68° water.
Rated point is guaranteed.

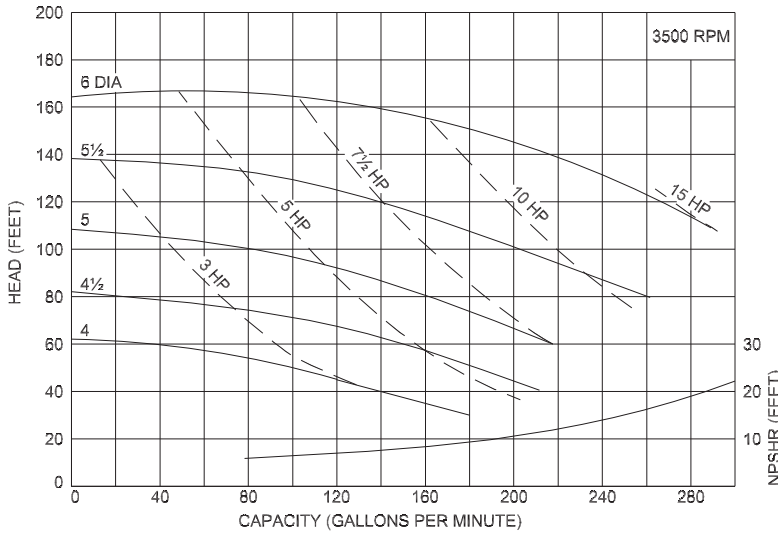

CB+ Series pumps have standard stainless steel adapters and utilize an internal seal.

CB+ Series pumps have a standard 32RA (150 grit) finish, on all product contact surfaces.

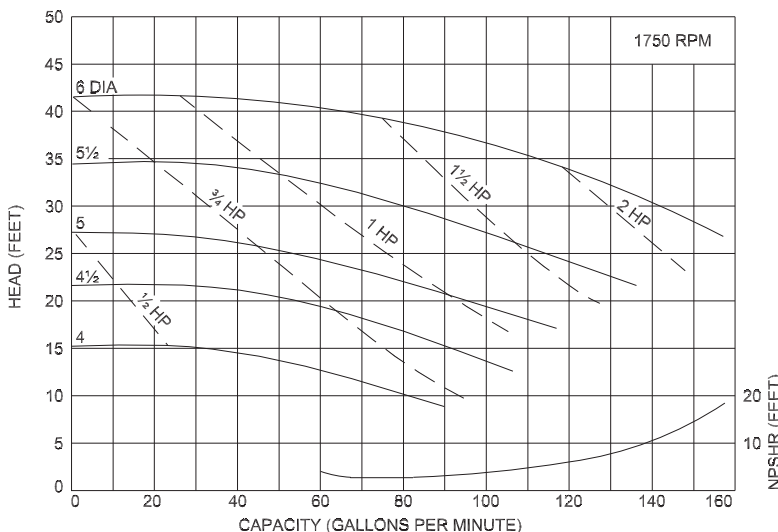

Ampco Pumps Company

2045 West Mill Road
Glendale, Wisconsin 53209
PHONE (414) 643-1852
FAX (414) 643-4452

Ampco Centrifugal Pumps

DATA SHEET

Model CB+ 218 2 x 1½

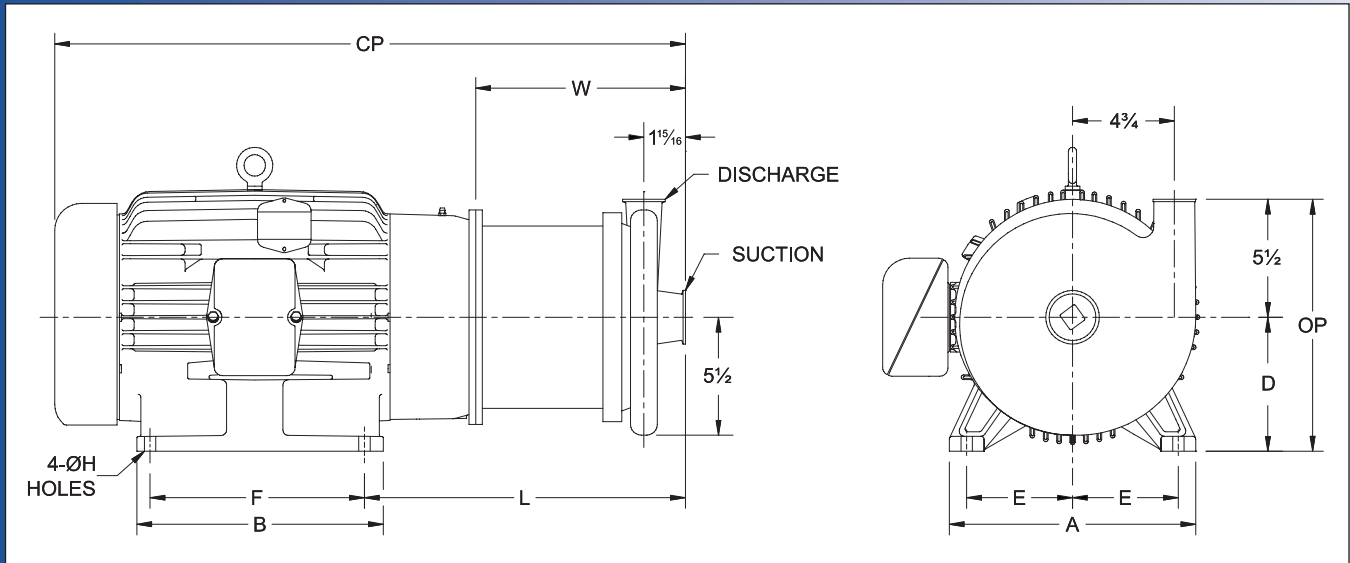
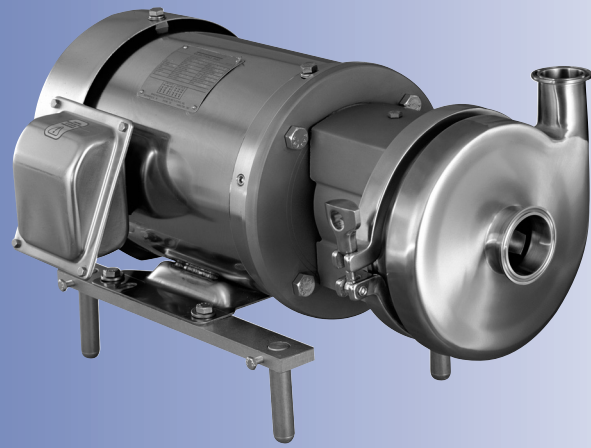

TEFC MOTOR			DIMENSIONS IN INCHES (For Reference Only)										APPROX WEIGHT (LBS)
HP	RPM	FRAME	A (typ)	B (typ)	D	E	F	ØH	L	W	CP	OP	
1-1/2	1750	145TC	6-1/2	6	3-1/2	2-3/4	5	11/32	10-15/16	8-3/16	19-7/16	9	88
2	1750	145TC	6-1/2	6	3-1/2	2-3/4	5	11/32	10-15/16	8-3/16	19-7/16	9	91
3	1750	182TC	8-5/8	6-1/2	4-1/2	3-3/4	4-1/2	13/32	12-5/16	8-13/16	22-9/16	10	121
5	1750	184TC	8-5/8	6-1/2	4-1/2	3-3/4	5-1/2	13/32	12-5/16	8-13/16	23-15/16	10	128
7-1/2	1750	213TC	9-1/2	8	5-1/4	4-1/4	5-1/2	13/32	13-7/16	9-3/16	24-7/16	10-3/4	182
5	3500	184TC	8-5/8	6-1/2	4-1/2	3-3/4	5-1/2	13/32	12-5/16	8-13/16	23-15/16	10	123
7-1/2	3500	184TC	8-5/8	6-1/2	4-1/2	3-3/4	5-1/2	13/32	12-5/16	8-13/16	23-15/16	10	141
7-1/2	3500	213TC	9-1/2	8	5-1/4	4-1/4	5-1/2	13/32	13-7/16	9-3/16	24-7/16	10-3/4	145
10	3500	215TC	9-1/2	8	5-1/4	4-1/4	7	13/32	13-7/16	9-3/16	26-3/16	10-3/4	178
15	3500	215TC	9-1/2	8	5-1/4	4-1/4	7	13/32	13-7/16	9-3/16	26-3/16	10-3/4	218
20	3500	256TC	11-1/2	11-1/2	6-1/4	5	10	17/32	14-13/16	10-1/16	30-7/16	11-3/4	326
25	3500	284TSC	12-3/4	12-3/4	7	5-1/2	9-1/2	17/32	15-7/16	10-11/16	34-3/8	12-1/2	418
30	3500	286TSC	12-3/4	12-3/4	7	5-1/2	11	17/32	15-7/16	10-11/16	34-3/8	12-1/2	440

MATERIAL SPECIFICATIONS

PART NAME	STAINLESS STEEL
Casing	316L Stainless
Backplate, Impeller, Stub Shaft	316L Stainless
Adapter	304 Stainless

Ampco Centrifugal Pumps

Model CB+ 218 2 x1½

Curves show approximate characteristics
based on clear 68° water.
Rated point is guaranteed.

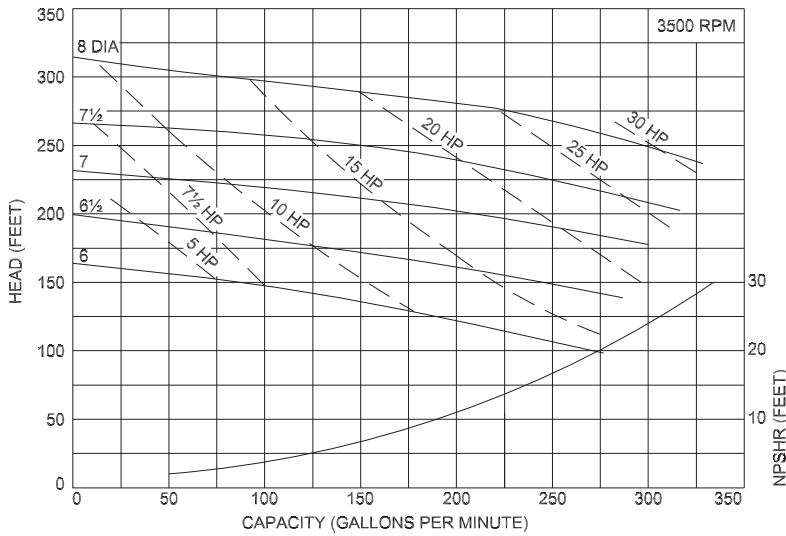

CB+ Series pumps have standard stainless steel adapters and utilize an internal seal.

CB+ Series pumps have a standard 32RA (150 grit) finish, on all product contact surfaces.

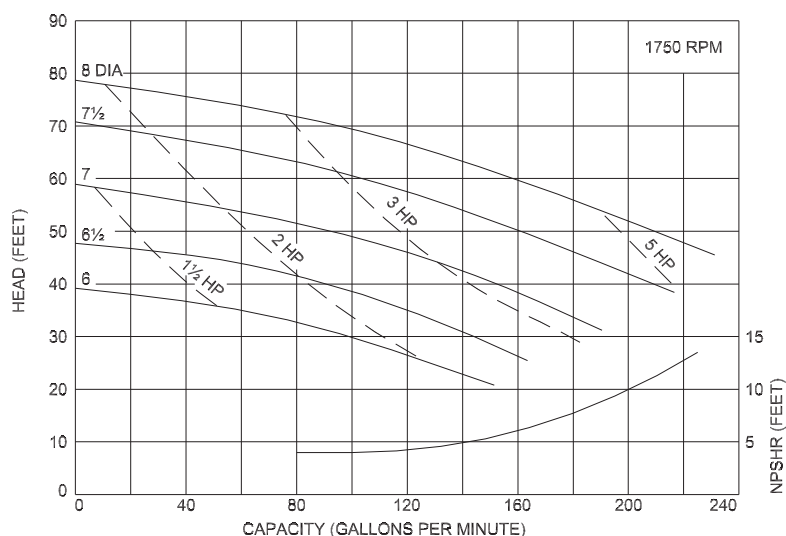
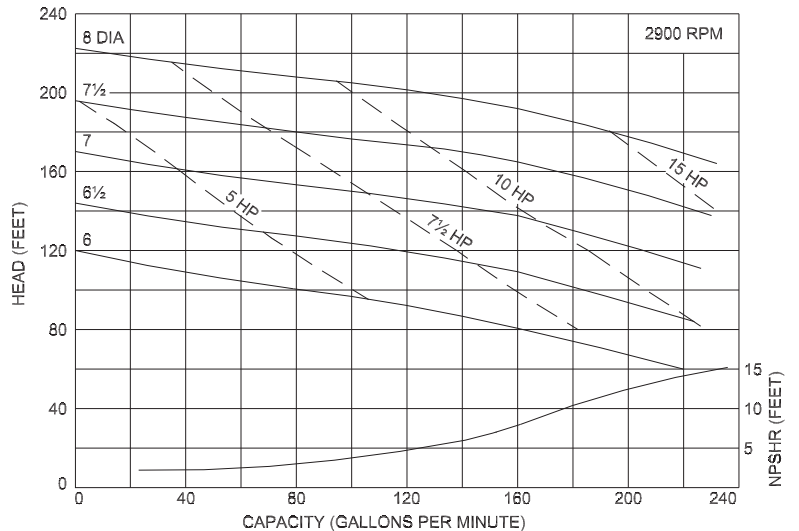

Ampco Pumps Company

2045 West Mill Road
Glendale, Wisconsin 53209
PHONE (414) 643-1852
FAX (414) 643-4452

Ampco Centrifugal Pumps

DATA SHEET

Model CB+ 318

3x1½

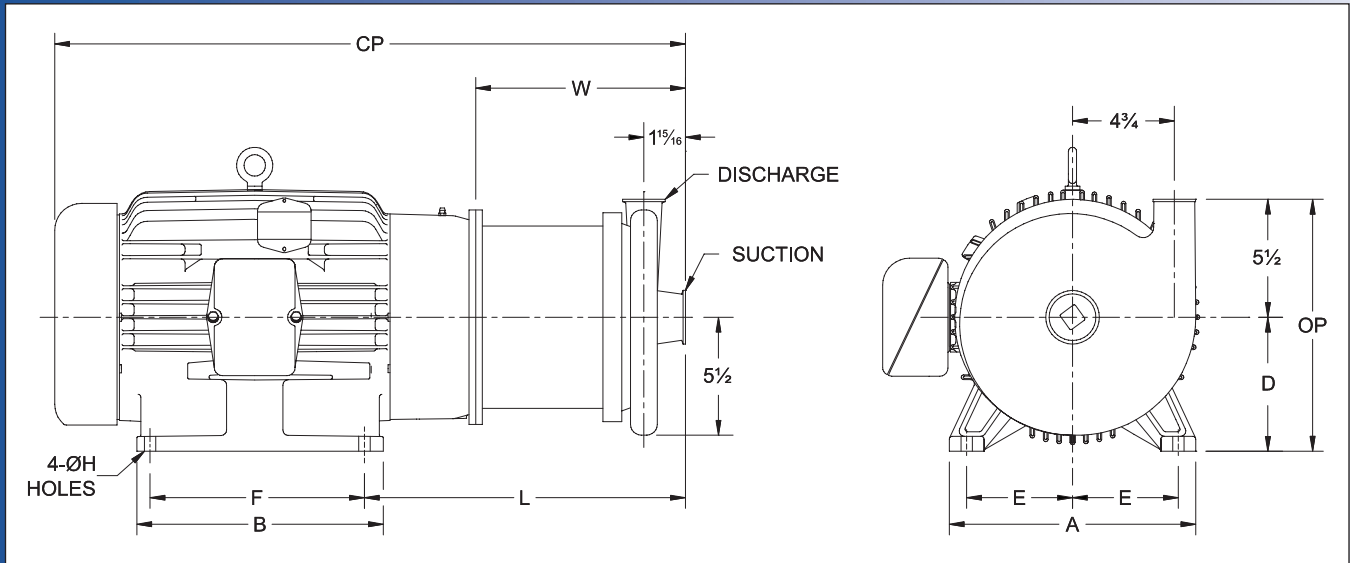
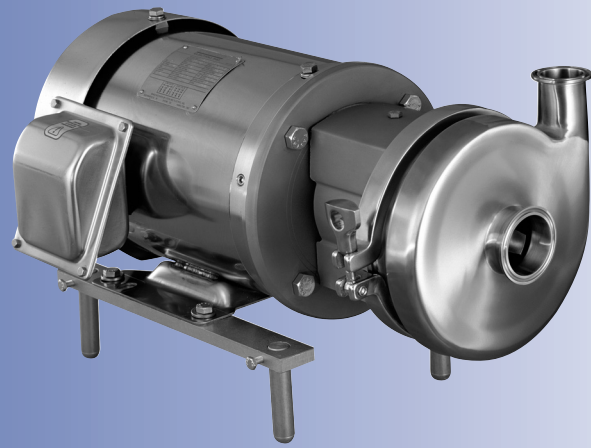

TEFC MOTOR			DIMENSIONS IN INCHES (For Reference Only)										APPROX WEIGHT (LBS)
HP	RPM	FRAME	A (typ)	B (typ)	D	E	F	ØH	L	W	CP	OP	
1-1/2	1750	145TC	6-1/2	6	3-1/2	2-3/4	5	11/32	10-15/16	8-3/16	19-7/16	9	88
2	1750	145TC	6-1/2	6	3-1/2	2-3/4	5	11/32	10-15/16	8-3/16	19-7/16	9	91
3	1750	182TC	8-5/8	6-1/2	4-1/2	3-3/4	4-1/2	13/32	12-5/16	8-13/16	22-9/16	10	121
5	1750	184TC	8-5/8	6-1/2	4-1/2	3-3/4	5-1/2	13/32	12-5/16	8-13/16	23-15/16	10	128
7-1/2	1750	213TC	9-1/2	8	5-1/4	4-1/4	5-1/2	13/32	13-7/16	9-3/16	24-7/16	10-3/4	182
5	3500	184TC	8-5/8	6-1/2	4-1/2	3-3/4	5-1/2	13/32	12-5/16	8-13/16	23-15/16	10	123
7-1/2	3500	184TC	8-5/8	6-1/2	4-1/2	3-3/4	5-1/2	13/32	12-5/16	8-13/16	23-15/16	10	141
7-1/2	3500	213TC	9-1/2	8	5-1/4	4-1/4	5-1/2	13/32	13-7/16	9-3/16	24-7/16	10-3/4	145
10	3500	215TC	9-1/2	8	5-1/4	4-1/4	7	13/32	13-7/16	9-3/16	26-3/16	10-3/4	178
15	3500	215TC	9-1/2	8	5-1/4	4-1/4	7	13/32	13-7/16	9-3/16	26-3/16	10-3/4	218
20	3500	256TC	11-1/2	11-1/2	6-1/4	5	10	17/32	14-13/16	10-1/16	30-7/16	11-3/4	326
25	3500	284TSC	12-3/4	12-3/4	7	5-1/2	9-1/2	17/32	15-7/16	10-11/16	34-3/8	12-1/2	418
30	3500	286TSC	12-3/4	12-3/4	7	5-1/2	11	17/32	15-7/16	10-11/16	34-3/8	12-1/2	440

MATERIAL SPECIFICATIONS

PART NAME	STAINLESS STEEL
Casing	316L Stainless
Backplate, Impeller, Stub Shaft	316L Stainless
Adapter	304 Stainless

Ampco Centrifugal Pumps

Model CB+ 318 3 x 1½

Curves show approximate characteristics
based on clear 68° water.
Rated point is guaranteed.

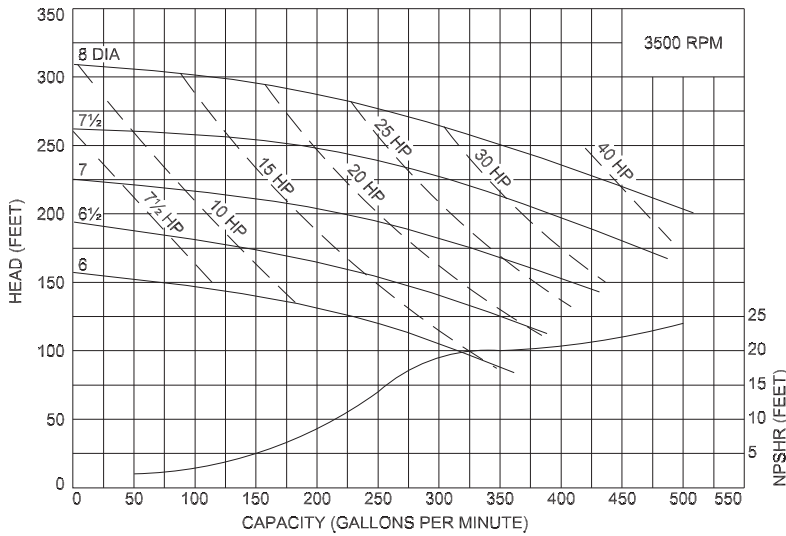

CB+ Series pumps have standard stainless steel adapters and utilize an internal seal.

CB+ Series pumps have a standard 32RA (150 grit) finish, on all product contact surfaces.

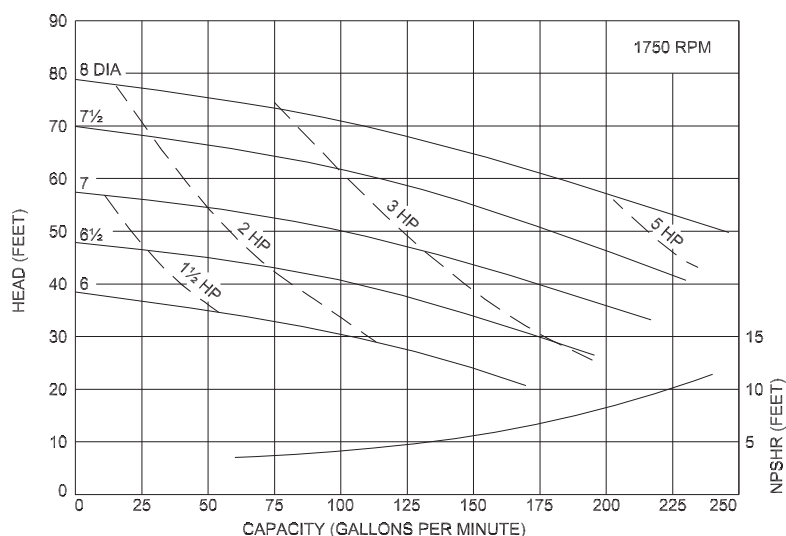
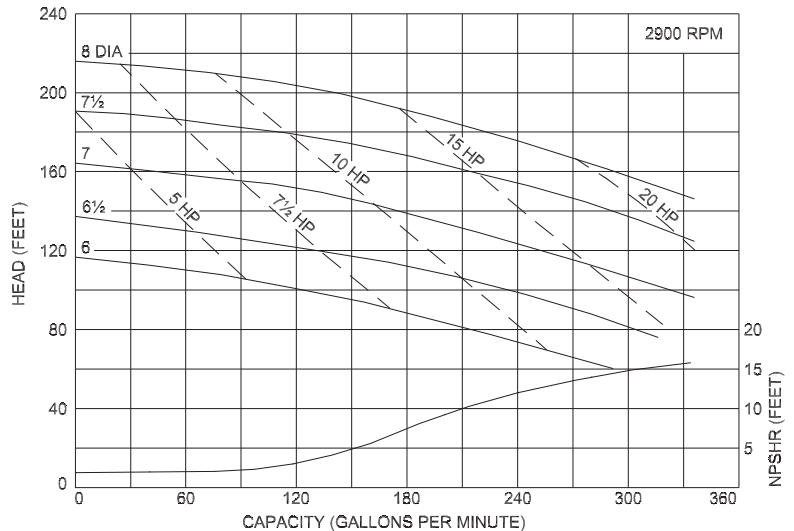

Ampco Pumps Company

2045 West Mill Road
Glendale, Wisconsin 53209
PHONE (414) 643-1852
FAX (414) 643-4452

Ampco Centrifugal Pumps

DATA SHEET

Model CB+ 328 3x2

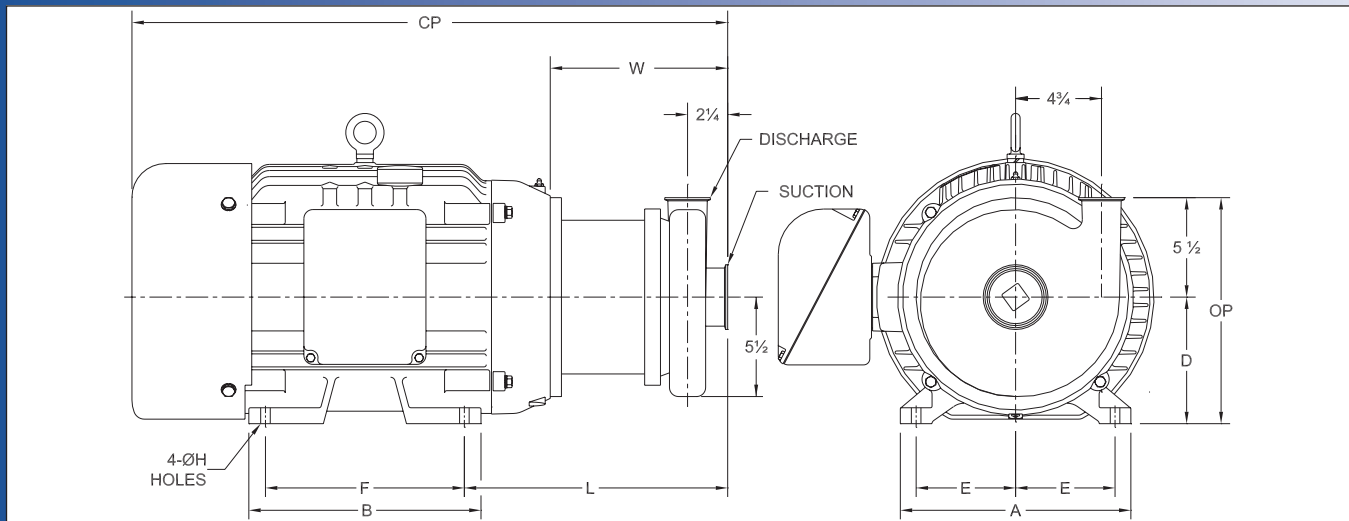
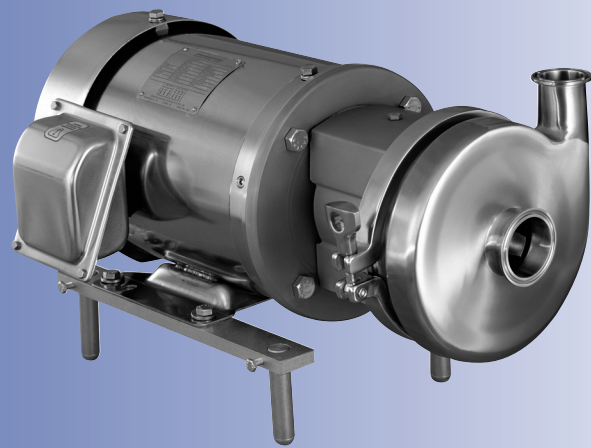

TEFC MOTOR			DIMENSIONS IN INCHES (For Reference Only)										APPROX WEIGHT (LBS)
HP	RPM	FRAME	A (typ)	B (typ)	D	E	F	ØH	L	W	CP	OP	
2	1750	145TC	6-1/2	6	3-1/2	2-3/4	5	11/32	11-9/16	8-13/16	19-7/16	9	97
3	1750	182TC	8-5/8	6-1/2	4-1/2	3-3/4	4-1/2	13/32	12-15/16	9-7/16	22-9/16	10	124
5	1750	184TC	8-5/8	6-1/2	4-1/2	3-3/4	5-1/2	13/32	12-15/16	9-7/16	23-15/16	10	131
7-1/2	1750	213TC	9-1/2	8	5-1/4	4-1/4	5-1/2	13/32	14-1/16	9-13/16	24-7/16	10-3/4	183
10	1750	215TC	9-1/2	8	5-1/4	4-1/4	7	13/32	14-1/16	9-13/16	26-3/16	10-3/4	193
5	3500	184TC	8-5/8	6-1/2	4-1/2	3-3/4	5-1/2	13/32	12-15/16	9-7/16	23-15/16	10	126
7-1/2	3500	184TC	8-5/8	6-1/2	4-1/2	3-3/4	5-1/2	13/32	12-15/16	9-7/16	23-15/16	10	144
7-1/2	3500	213TC	9-1/2	8	5-1/4	4-1/4	5-1/2	13/32	14-1/16	9-13/16	24-7/16	10-3/4	146
10	3500	215TC	9-1/2	8	5-1/4	4-1/4	7	13/32	14-1/16	9-13/16	26-3/16	10-3/4	179
15	3500	215TC	9-1/2	8	5-1/4	4-1/4	7	13/32	14-1/16	9-13/16	26-3/16	10-3/4	219
20	3500	256TC	11-1/2	11-1/2	6-1/4	5	10	17/32	15-7/16	10-11/16	28-5/16	11-3/4	328
25	3500	284TSC	12-3/4	12-3/4	7	5-1/2	9-1/2	17/32	16-1/16	11-5/16	31-1/16	12-1/2	420
30	3500	286TSC	12-3/4	12-3/4	7	5-1/2	11	17/32	16-1/16	11-5/16	34-7/16	12-1/2	442
40	3500	324TSC	14-1/2	14	8	6-1/4	10-1/2	21/32	17-1/8	11-7/8	34-3/8	13-1/2	549
50	3500	326TSC	14-1/2	14	8	6-1/4	12	21/32	17-1/8	11-7/8	36	13-1/2	651

MATERIAL SPECIFICATIONS

PART NAME	STAINLESS STEEL
Casing	316L Stainless
Backplate, Impeller, Stub Shaft	316L Stainless
Adapter	304 Stainless

Ampco Centrifugal Pumps

Model CB+ 328 3x2

Curves show approximate characteristics
based on clear 68° water.
Rated point is guaranteed.

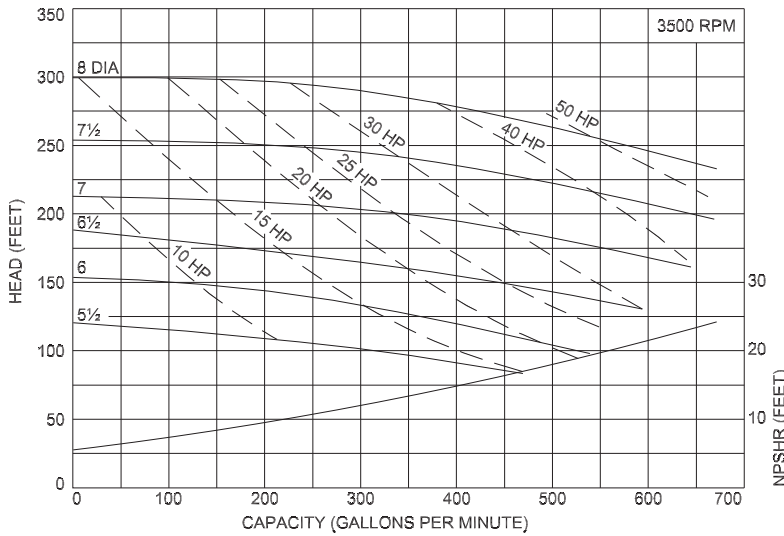

CB+ Series pumps have standard stainless steel adapters and utilize an internal seal.

CB+ Series pumps have a standard 32RA (150 grit) finish, on all product contact surfaces.

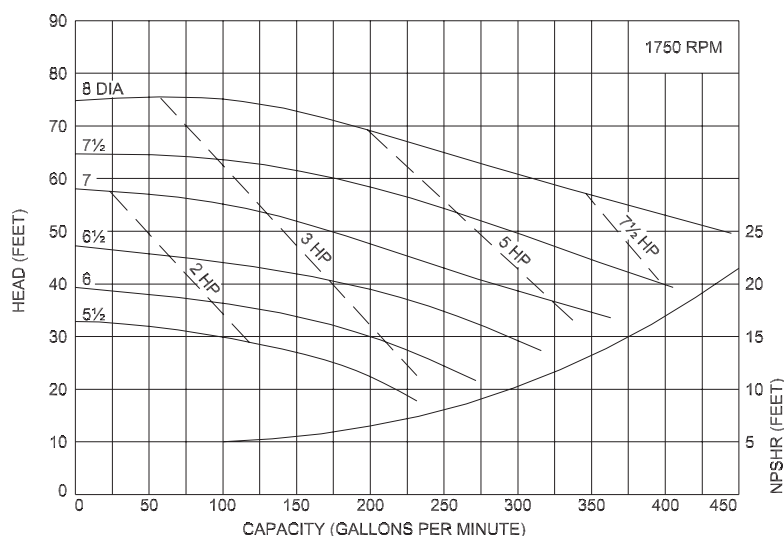
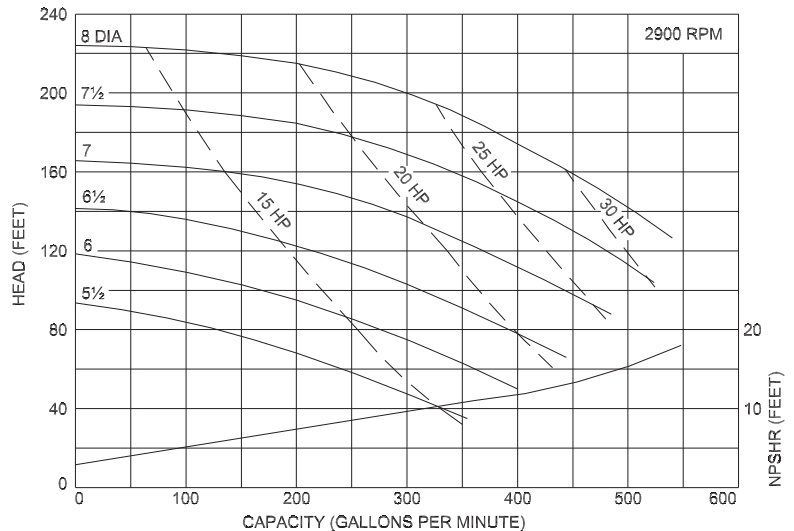

Ampco Pumps Company

2045 West Mill Road
Glendale, Wisconsin 53209
PHONE (414) 643-1852
FAX (414) 643-4452

Ampco Centrifugal Pumps

DATA SHEET

Model CB+ 428 4x2

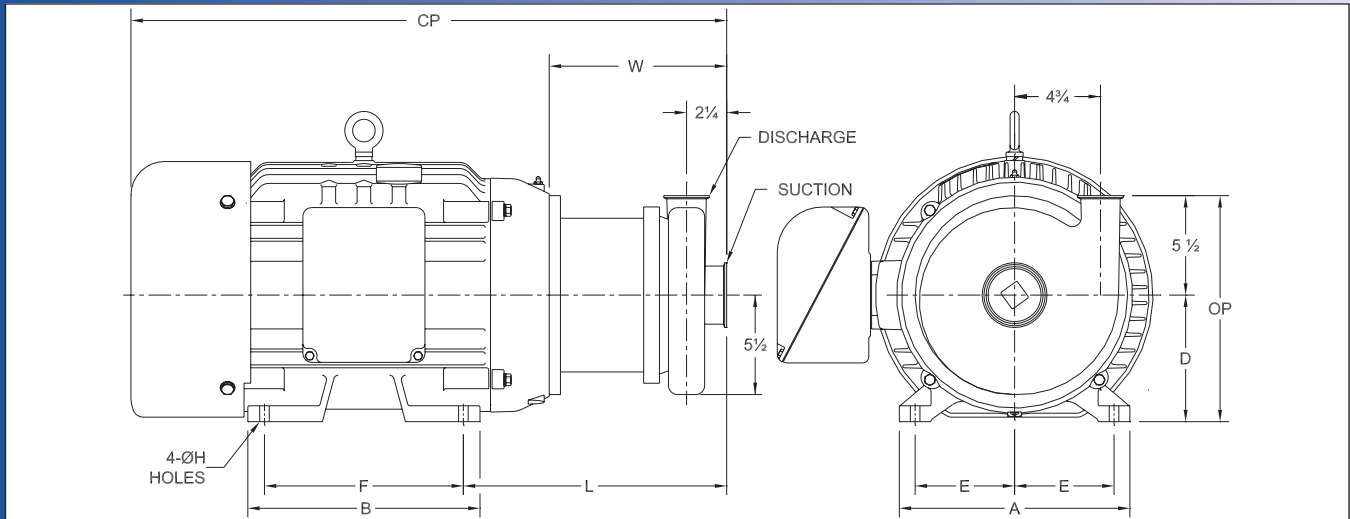
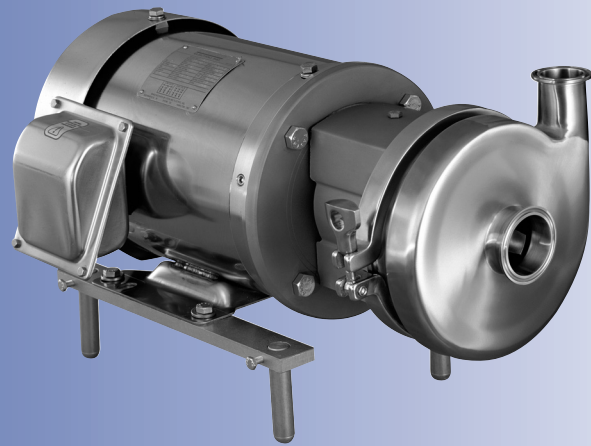

TEFC MOTOR			DIMENSIONS IN INCHES (For Reference Only)										APPROX WEIGHT (LBS)
HP	RPM	FRAME	A (typ)	B (typ)	D	E	F	ØH	L	W	CP	OP	
2	1750	145TC	6-1/2	6	3-1/2	2-3/4	5	11/32	11-9/16	8-13/16	19-7/16	9	97
3	1750	182TC	8-5/8	6-1/2	4-1/2	3-3/4	4-1/2	13/32	12-15/16	9-7/16	22-9/16	10	124
5	1750	184TC	8-5/8	6-1/2	4-1/2	3-3/4	5-1/2	13/32	12-15/16	9-7/16	23-15/16	10	131
7-1/2	1750	213TC	9-1/2	8	5-1/4	4-1/4	5-1/2	13/32	14-1/16	9-13/16	24-7/16	10-3/4	183
10	1750	215TC	9-1/2	8	5-1/4	4-1/4	7	13/32	14-1/16	9-13/16	26-3/16	10-3/4	193
5	3500	184TC	8-5/8	6-1/2	4-1/2	3-3/4	5-1/2	13/32	12-15/16	9-7/16	23-15/16	10	126
7-1/2	3500	184TC	8-5/8	6-1/2	4-1/2	3-3/4	5-1/2	13/32	12-15/16	9-7/16	23-15/16	10	144
7-1/2	3500	213TC	9-1/2	8	5-1/4	4-1/4	5-1/2	13/32	14-1/16	9-13/16	24-7/16	10-3/4	146
10	3500	215TC	9-1/2	8	5-1/4	4-1/4	7	13/32	14-1/16	9-13/16	26-3/16	10-3/4	179
15	3500	215TC	9-1/2	8	5-1/4	4-1/4	7	13/32	14-1/16	9-13/16	26-3/16	10-3/4	219
20	3500	256TC	11-1/2	11-1/2	6-1/4	5	10	17/32	15-7/16	10-11/16	28-5/16	11-3/4	328
25	3500	284TSC	12-3/4	12-3/4	7	5-1/2	9-1/2	17/32	16-1/16	11-5/16	31-1/16	12-1/2	420
30	3500	286TSC	12-3/4	12-3/4	7	5-1/2	11	17/32	16-1/16	11-5/16	34-7/16	12-1/2	442
40	3500	324TSC	14-1/2	14	8	6-1/4	10-1/2	21/32	17-1/8	11-7/8	34-3/8	13-1/2	549
50	3500	326TSC	14-1/2	14	8	6-1/4	12	21/32	17-1/8	11-7/8	36	13-1/2	651

MATERIAL SPECIFICATIONS

PART NAME	STAINLESS STEEL
Casing	316L Stainless
Backplate, Impeller, Stub Shaft	316L Stainless
Adapter	304 Stainless

Ampco Centrifugal Pumps

Model CB+ 428 4x2

Curves show approximate characteristics
based on clear 68° water.
Rated point is guaranteed.

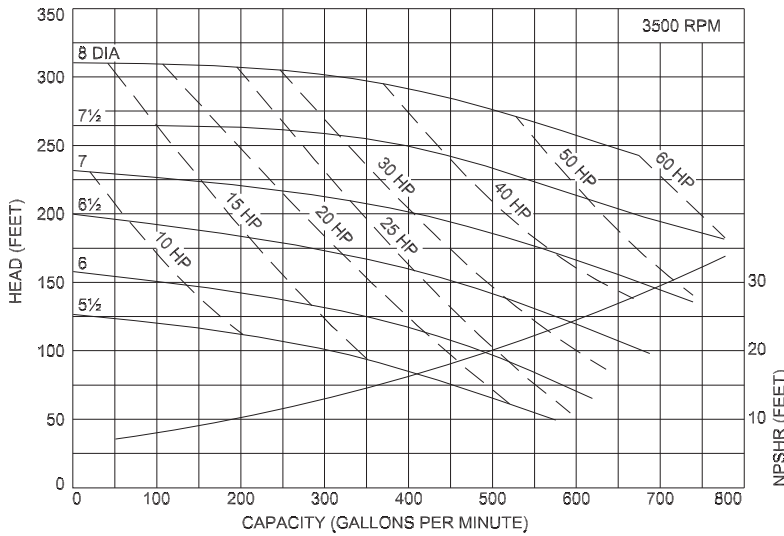

CB+ Series pumps have standard stainless steel adapters and utilize an internal seal.

CB+ Series pumps have a standard 32RA (150 grit) finish, on all product contact surfaces.

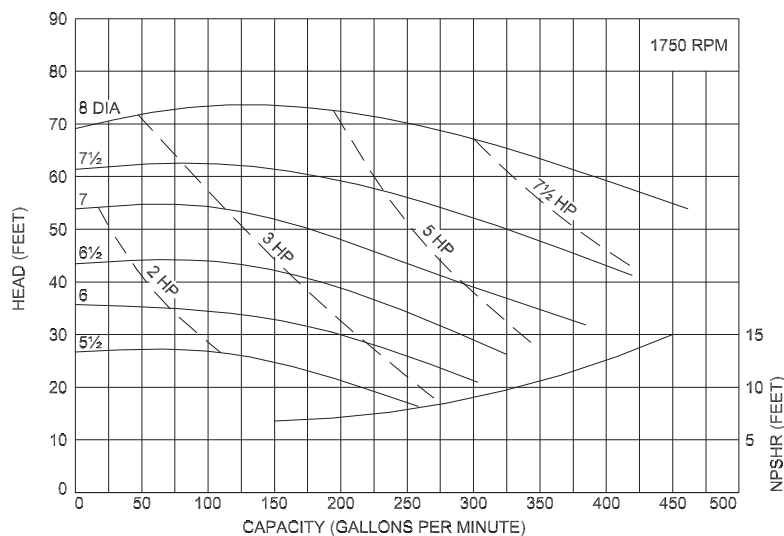
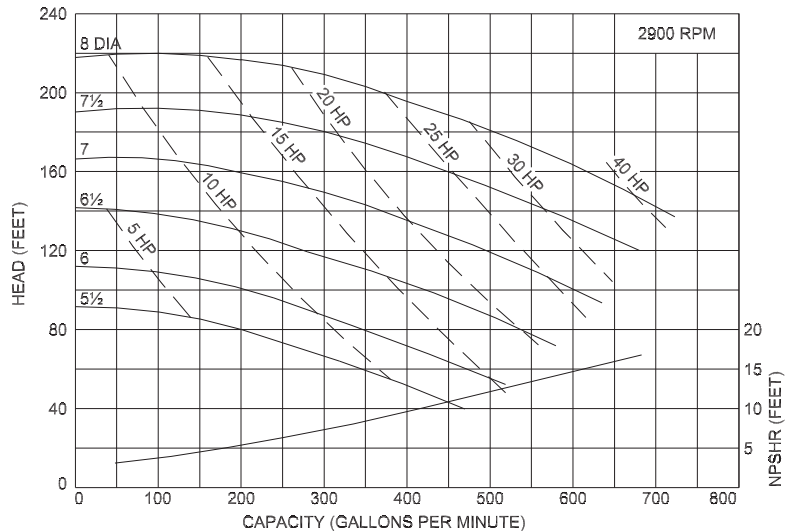

Ampco Pumps Company

2045 West Mill Road
Glendale, Wisconsin 53209
PHONE (414) 643-1852
FAX (414) 643-4452

Ampco Centrifugal Pumps

DATA SHEET

Model CB+ 4410 4x4

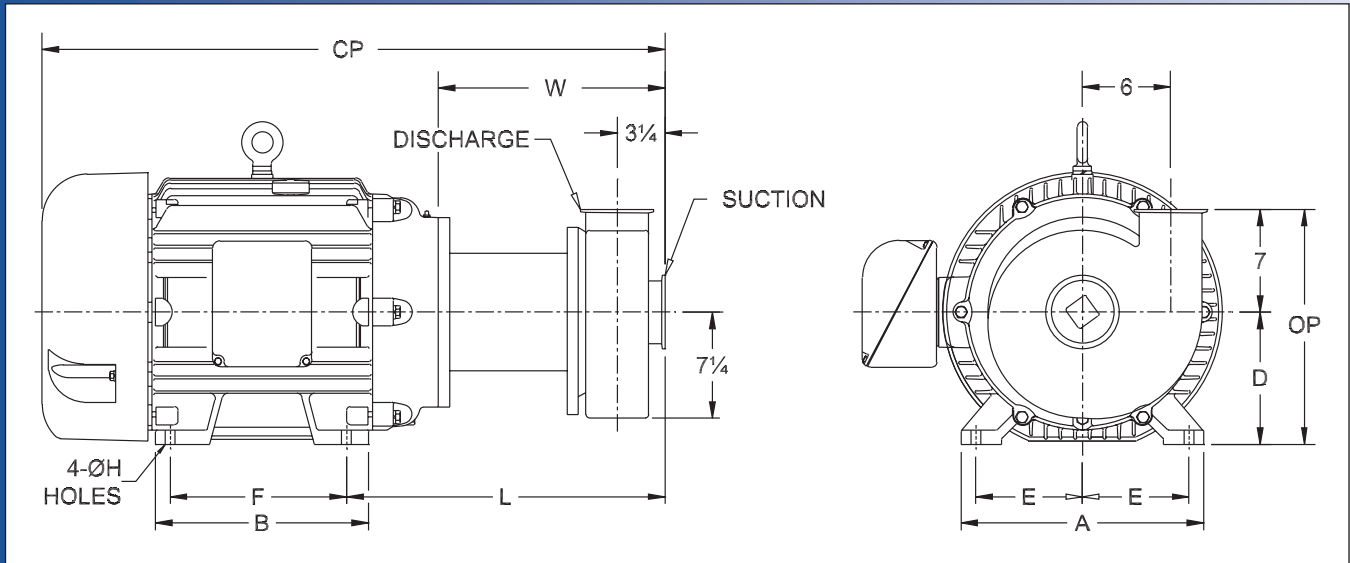
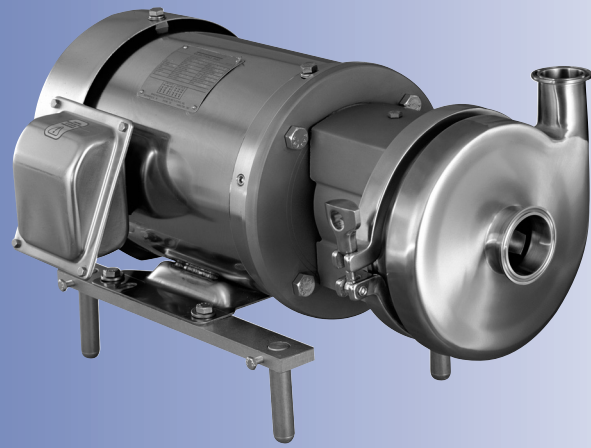

TEFC MOTOR			DIMENSIONS IN INCHES (For Reference Only)										APPROX WEIGHT (LBS)
HP	RPM	FRAME	A (typ)	B (typ)	D	E	F	ØH	L	W	CP	OP	
7-1/2	1750	213TC	9-1/2	8	5-1/4	4-1/4	5-1/2	13/32	17-1/4	13	28-1/4	12-1/4	230
10	1750	215TC	9-1/2	8	5-1/4	4-13/4	7	13/32	17-1/4	13	30	12-1/4	240
15	1750	254TC	11-1/2	11-1/2	6-1/4	5	8-1/4	17/32	17-3/4	13	30-5/8	13-1/4	358
20	1750	256TC	11-1/2	11-1/2	6-1/4	5	10	17/32	17-3/4	13	32-3/4	13-1/4	381
25	1750	284TC	12-3/4	12-3/4	7	5-1/2	9-1/2	17/32	18-3/8	13-5/8	36-7/16	14	514
30	1750	286TC	12-3/4	12-3/4	7	5-1/2	11	17/32	18-3/8	13-5/8	36-7/16	14	525
20	3500	256TC	11-1/2	11-1/2	6-1/4	5	10	17/32	17-3/4	13	32-3/4	13-1/4	375
25	3500	284TSC	12-3/4	12-3/4	7	5-1/2	9-1/2	17/32	18-3/8	13-5/8	36-7/16	14	474
30	3500	286TSC	12-3/4	12-3/4	7	5-1/2	11	17/32	18-3/8	13-5/8	36-7/16	14	496
40	3500	324TSC	14-1/2	14	8	6-1/4	10-1/2	21/32	20-5/8	15-3/8	38-3/16	15	617
50	3500	326TSC	14-1/2	14	8	6-1/4	12	21/32	20-5/8	15-3/8	38-3/16	15	726
60	3500	364TSC	16-1/2	14-1/2	9	7	11-1/4	21/32	21-1/4	15-3/8	40-7/16	16	867
75	3500	365TSC	16-1/2	14-1/2	9	7	12-1/4	21/32	21-1/4	15-3/8	40-7/16	16	893

MATERIAL SPECIFICATIONS

PART NAME	STAINLESS STEEL
Casing	316L Stainless
Backplate, Impeller, Stub Shaft	316L Stainless
Adapter	304 Stainless

Ampco Centrifugal Pumps

Model CB+ 4410 4x4

Curves show approximate characteristics
based on clear 68° water.
Rated point is guaranteed.

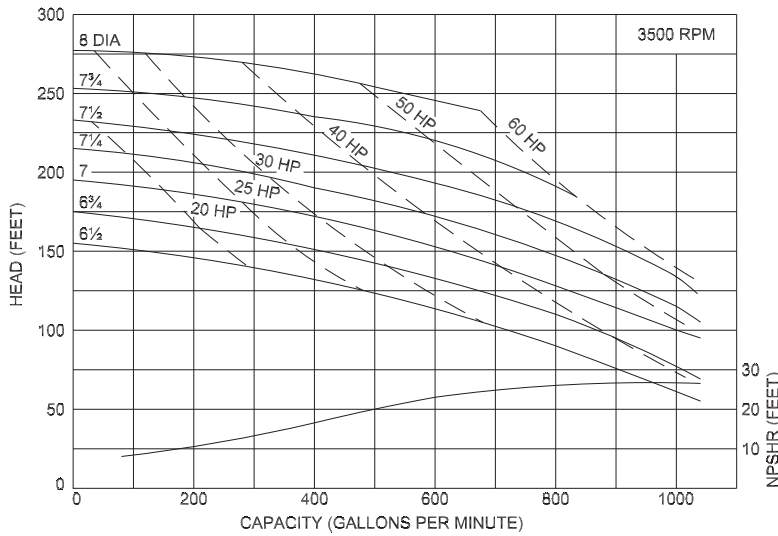

CB+ Series pumps have standard stainless steel adapters and utilize an internal seal.

CB+ Series pumps have a standard 32RA (150 grit) finish, on all product contact surfaces.

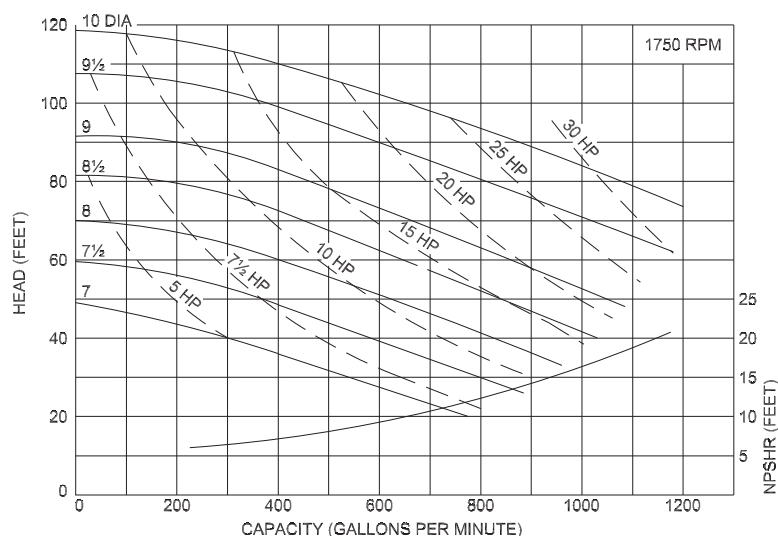
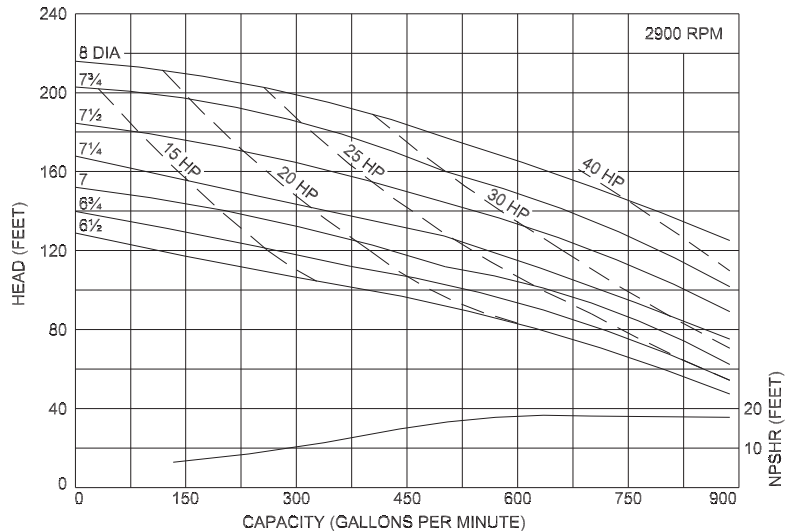

Ampco Pumps Company

2045 West Mill Road
Glendale, Wisconsin 53209
PHONE (414) 643-1852
FAX (414) 643-4452

Ampco Centrifugal Pumps

DATA SHEET

Model CB+ 6410 6x4

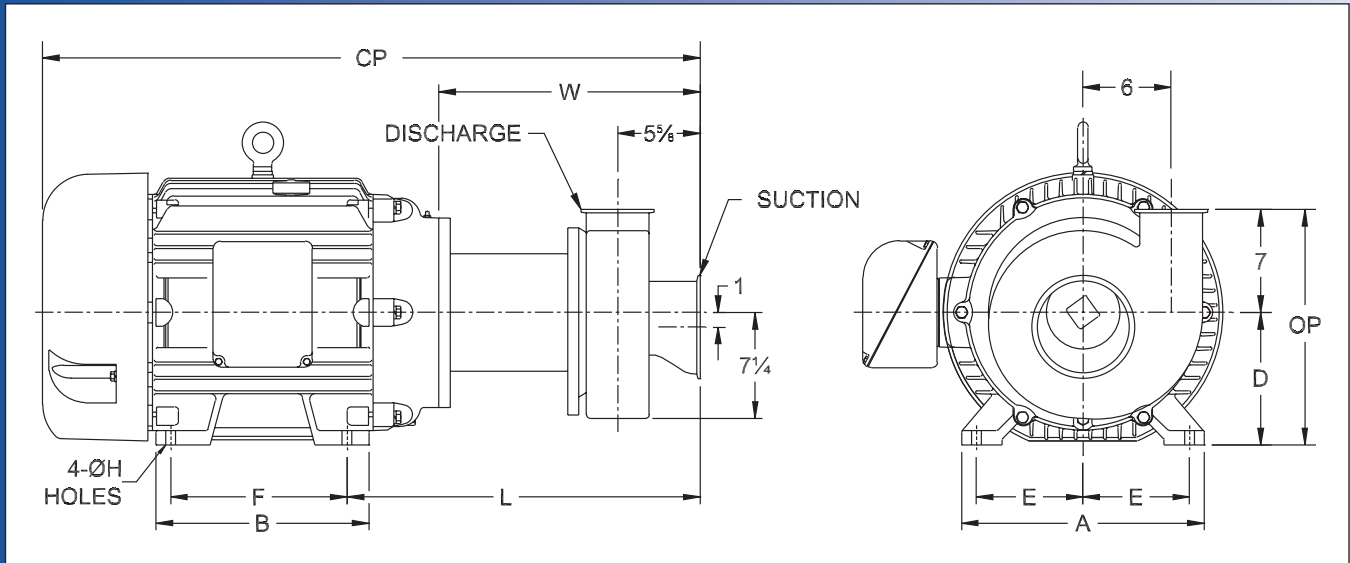
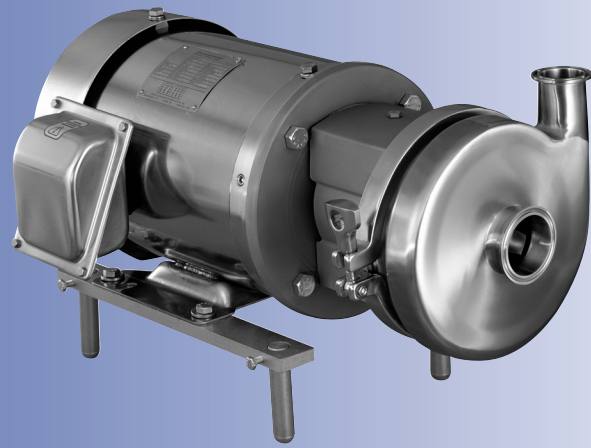

TEFC MOTOR			DIMENSIONS IN INCHES (For Reference Only)										APPROX WEIGHT (LBS)
HP	RPM	FRAME	A (typ)	B (typ)	D	E	F	ØH	L	W	CP	OP	
7-1/2	1750	213TC	9-1/2	8	5-1/4	4-1/4	5-1/2	13/32	19-5/8	15-3/8	30-5/8	12-1/4	230
10	1750	215TC	9-1/2	8	5-1/4	4-1/4	7	13/32	19-5/8	15-3/8	32-3/8	12-1/4	240
15	1750	254TC	11-1/2	11-1/2	6-1/4	5	8-1/4	17/32	19-5/8	15-3/8	33	13-1/4	358
20	1750	256TC	11-1/2	11-1/2	6-1/4	5	10	17/32	19-5/8	15-3/8	35-1/8	13-1/4	381
25	1750	284TC	12-3/4	12-3/4	7	5-1/2	9-1/2	17/32	19-5/8	16	38-13/16	14	514
30	1750	286TC	12-3/4	12-3/4	7	5-1/2	11	17/32	19-5/8	16	38-13/16	14	525
20	3500	256TC	11-1/2	11-1/2	6-1/4	5	10	17/32	19-5/8	15-3/8	35-1/8	13-1/4	375
25	3500	284TSC	12-3/4	12-3/4	7	5-1/2	9-1/2	17/32	19-5/8	16	38-13/16	14	474
30	3500	286TSC	12-3/4	12-3/4	7	5-1/2	11	17/32	19-5/8	16	38-13/16	14	496
40	3500	324TSC	14-1/2	14	8	6-1/4	10-1/2	21/32	19-5/8	17-3/4	40-9/16	15	617
50	3500	326TSC	14-1/2	14	8	6-1/4	12	21/32	19-5/8	17-3/4	40-9/16	15	726
60	3500	364TSC	16-1/2	14-1/2	9	7	11-1/4	21/32	19-5/8	17-3/4	42-13/16	16	867
75	3500	365TSC	16-1/2	14-1/2	9	7	12-1/4	21/32	19-5/8	17-3/4	42-13/16	16	893

MATERIAL SPECIFICATIONS

PART NAME	STAINLESS STEEL
Casing	316L Stainless
Backplate, Impeller, Stub Shaft	316L Stainless
Adapter	304 Stainless

Ampco Centrifugal Pumps

Model CB+ 6410 6x4

Curves show approximate characteristics
based on clear 68° water.
Rated point is guaranteed.

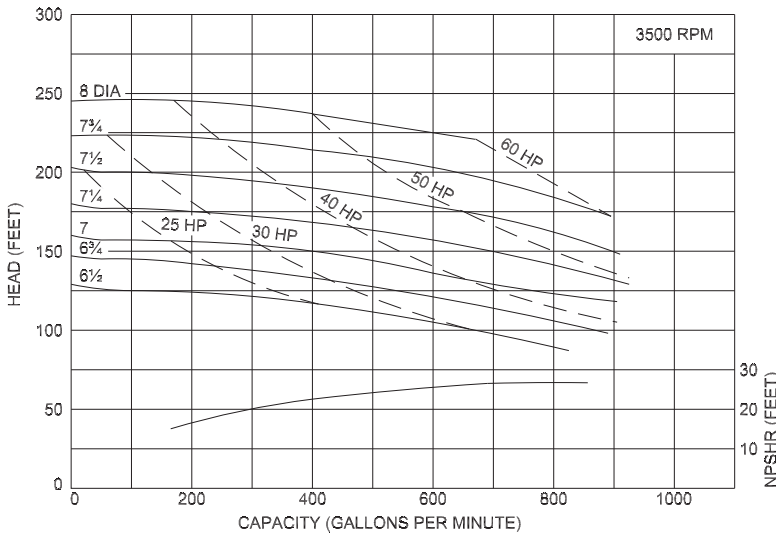

CB+ Series pumps have standard stainless steel adapters and utilize an internal seal.

CB+ Series pumps have a standard 32RA (150 grit) finish, on all product contact surfaces.

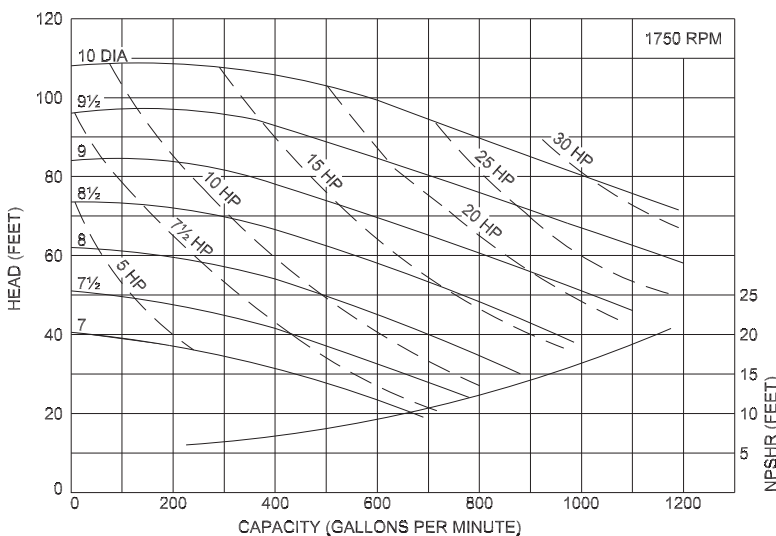
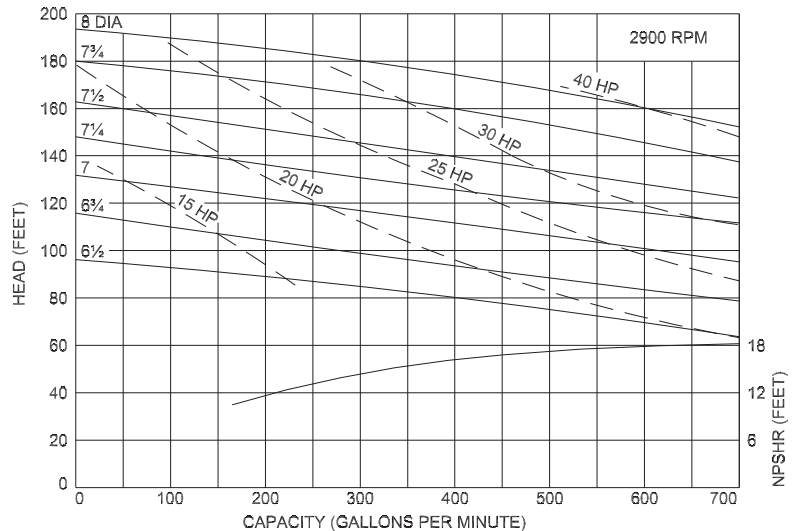

Ampco Pumps Company

2045 West Mill Road
Glendale, Wisconsin 53209
PHONE (414) 643-1852
FAX (414) 643-4452