



Aseptomag® Valve Technology – Order Code

T.VIS® Control top

T.VIS® control top

The T.VIS® control top is an optimal system for controlling and monitoring GEA Aseptomag® valves.

This is available in several variants depending on the valve type, tasks and user convenience.

Common features of all T.VIS® variants are:

- Flexible modular system for optimum variant configuration for the particular task (e.g. type of interface module, number of solenoid valves, etc.)
- Characteristic design
- High Protection class (min. IP66, optional IP67 or IP69k)
- Ease of cleaning without dead zones, whatever the installation orientation
- Clear visualization of the valve status via a light dome visible 360°, which is illuminated by colored LEDs
- Low energy consumption
- Ease of handling
- Maintenance-free electronic modules
- Many special options, e.g.:
 - Air throttles
 - Cable connections, etc.

For maintenance work on the valve, the control tops can be removed from the valve actuator by loosening two bolts on the clamp, without electrical or pneumatic connections having to be disconnected.

T.VIS® concept – for valves with pneumatic actuator



T.VIS® M-15 – control top with manual sensor setting

- For open/close position feedback and actuator control
- Proven sensor technology
- Modules and solenoid valves can be retrofitted



T.VIS® A-15 – control top with automatic set-up

- For open/close position feedback and actuator control
- Automatic set-up
- Semi-automatic setup

Function

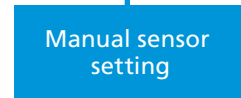
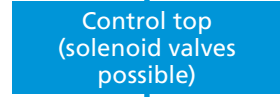

Product



Available interface

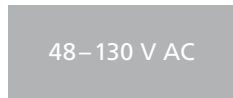

Available for

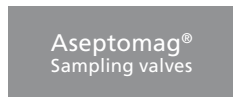

Concept

The T.VIS® M-15 is equipped with manually adjustable sensors and a modular system of options, all of which form the basics of the T.VIS® feedback technology. This means it is optimally adapted to the basic requirements of the process system.

With proven sensor technology, it offers the advantages of the modern T.VIS® series in an inexpensive manner.

Standard variant



- 1 Pneumatic block
- 2 24 V DC interface module
- 3 Sensors
- 4 Solenoid valves
- 5 LED lighting
- 6 Central compressed air connection with replaceable filter
- 7 Cable gland

Features

Flexible modular system
Use of proven sensor technology
Quick and easy adjustment of the sensors
Valve status indication by LED
Various communication standards available
Components can be upgraded/converted subsequently
Filter protects solenoid valves
High-quality pneumatic fittings
Exchangeable compressed air connection
Supply and exhaust air throttles can be fitted
Standard protection class IP66

Structure

The T.VIS® M-15 is characterized by proven sensor technology. The basic equipment of the control top comprises of the 24 V DC interface module with two sensors for feedback of the valve position and up to three solenoid valves, which can be installed subsequently, if necessary.

In the interface types with AC (alternating current), DeviceNet and AS-Interface, an adapter module is connected ahead of the standard interface module, and can also be retrofitted or converted.

A replaceable filter in the supply air connection protects the solenoid valves.

Position detection

Inductive sensor system – The valve positions are detected using two manually adjustable sensors.

Setting

Mechanical – The sensors are calibrated mechanically using the positioning spindles, which are subsequently secured to prevent self-adjustment.

Visualization

LED display:

- green
- yellow





Technical data of the standard version		
Position detection	Sensors	
Housing material	PA 12/L	
Ambient temperature	-20 to 60 °C	
Air supply	Pressure range	2 to 8 bar
	Standard	acc. to ISO 8573-1:2010
	Solid content	Quality class 6
	Water content	Quality class 4
	Oil content	Quality class 3
Dimensions of air connections	Metric 6/4 mm, inch 6.35/4.31 mm (¼")	
Protection class	IP66 (powerful water jet)	
Sound pressure level via exhaust air throttle	Max. 72 dB	
Visualization	LED (green, yellow)	

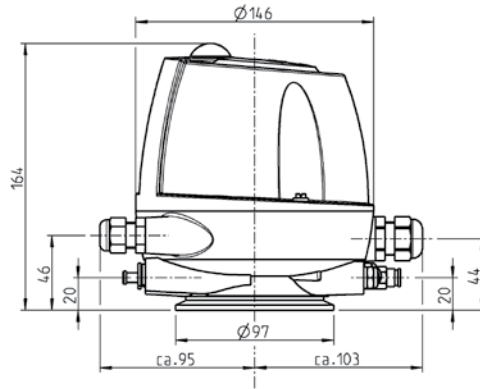

Type of interface	24 V DC, 3-wire, PNP 24 V DC, 3-wire, NPN	48 – 130 V AC
Supply		
Operating voltage	24 V DC (+20 %, -12.5 %)	48 – 130 V AC
No-load current	≤ 40 mA	≤ 51 mA
Maximum current consumption	285 mA	185 mA
Polarity reversal protection	Yes	Yes
Inputs		
Activation voltage	21 – 28.8 V = high; < 16 V = low	48 – 130 V = high*; < 30 V = low > 1.5 mA = high*; < 0.4 mA = low
Current consumption per input	≤ 35 mA	≤ 3 mA
Activation "PV Y1"	Direct PV activation	Electronic input
Activation "PV Y2"	Direct PV activation	Electronic input
Activation "PV Y3"	Direct PV activation	Electronic input
Outputs		
Connection type	24 V DC (PNP/NPN with changeover function)	
Maximum current carrying capacity per feedback output	50 mA	≤ 100 mA
Voltage drop on the outputs	≤ 3 V	≤ 5 V
Feedback "start position"	Electronic outputs	Electronic outputs
Feedback "end position"	Electronic outputs	Electronic outputs
Feedback "seat lift position"	Electronic outputs	Electronic outputs

* Leakage currents can arise if PLC modules with electronic outputs are used. If the leakage currents are more than 1.5 mA, it is essential to use a load resistor in parallel with the interface module. Recommendation: 15 kΩ/2 W



Technical data of the standard version		
Position detection	Sensors	
Housing material	PA 12/L	
Ambient temperature	-20 to 60 °C	
Air supply	Pressure range	2 to 8 bar
	Standard	acc. to ISO 8573-1:2010
	Solid content	Quality class 6
	Water content	Quality class 4
	Oil content	Quality class 3
Dimensions of air connections	Metric 6/4 mm, inch 6.35/4.31 mm (¼")	
Protection class	IP66 (powerful water jet)	
Sound pressure level via exhaust air throttle	Max. 72 dB	
Visualization	LED (green, yellow)	

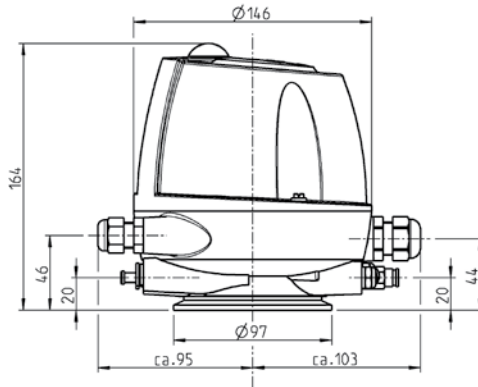

Type of interface	AS-Interface bus	DeviceNet
Supply		
Operating voltage	25.0–31.6 V DC	21–26 V DC
No-load current	≤ 62 mA	≤ 58 mA (at 24 V DC)
Maximum current consumption	225 mA	235 mA
Polarity reversal protection	Yes	Yes
Specification	AS-i V3.0 (max. 62 slaves with master V3.0)	ODVA-compliant
Additional information	IO.ID.ID2-code: 7.A.E	EDS file: F1022_R4.eds
Conformity	AS-i association	ODVA
Inputs		
Feedback "start position"	Data bit DI 0	Data bit I-0
Feedback "end position"	Data bit DI 1	Data bit I-1
Feedback "seat lift position" (ext. NI)	Data bit DI 2	Data bit I-2
Collective fault		Data bit I-7
Outputs		
Activation "PV Y1"	Data bit DO 0	Data bit O-0
Activation "PV Y2"	Data bit DO 1	Data bit O-1
Activation "PV Y3"	Data bit DO 2	Data bit O-2

Concept

The T.VIS® A-15 is equipped with a high-precision path measuring system. This automatic open/close position recognition is available on any valve from GEA, along with a T.VIS® feedback system.

Development has focussed on the requirements and necessities of our customers from the fluid-processing industry. In addition to safe control and monitoring of all functions of the process valves in breweries, dairies, plants for manufacturing fruit juices as well as pharmaceuticals, the T.VIS® A-15 offers significant advantages that are directly reflected in lower total cost of ownership.

Standard variant

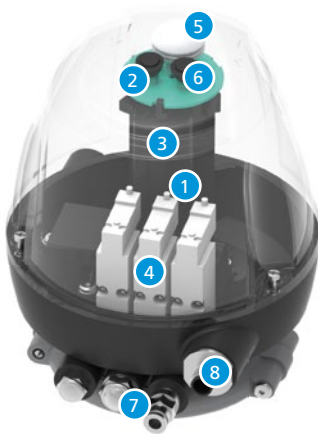

- 1 Pneumatic block
- 2 Control unit
- 3 Path measuring system
- 4 Solenoid valves
- 5 LED lighting
- 6 2 push buttons
- 7 Central compressed air connection with replaceable filter
- 8 M12 plug connection

Features

Quick, automatic initialization
Tamper-proof setting of tolerances
Reduced energy consumption
Reduction in operating costs
Valve status display by LED
Basic LED colors can be selected specifically for the customer
Filter protects solenoid valves
High-quality pneumatic fittings
Exchangeable compressed air connection
Supply and exhaust air throttles can be fitted
LEFF® function
Semi-automatic setup
Standard protection class IP66

Structure

The T.VIS® A-15 is equipped with a precise path measuring system for detecting its position.

The necessary wiring for control and feedback is performed, depending on the requirements, via the M12 plug connections accessible from the outside or through direct wiring and cable glands.

The control top can be opened for this.

Operation and configuration of the T.VIS® A-15 takes place either by the two push buttons on the cap or, with the cap removed, via the buttons below. The push buttons are secured electronically against inadvertent or incorrect operation, while in operating mode.

A replaceable filter, in the supply air connection, protects the solenoid valves.

Position detection

Path measuring system – the valve position is registered by means of a highly modern path measuring system.

Setting

Automatic – following unlocking, simply pressing the two buttons on the cap of the T.VIS® A-15 starts the initialization process which runs fully automatically. There is no need to open the control top for this purpose, resulting in particularly quick, easy and safe commissioning of the control top (on average < 1 minute).

Immediately following the set-up, it is possible to set the open/close position tolerances and signal attenuation in the parameter menu.

LEFF® function

LEFF® (Low Emission Flip Flop) is available in double-seat valves for each lifted and monitored valve disc. The function describes modulation of the valve disc during the lifting process to reduce the consumption of cleaning agent.

Semi-automatic setup

As a new feature, our control top T.VIS® A-15 has the option of semi-automatic setup that permits uncomplicated exchange in the current process.

For more information about the semi-automatic setup, refer to the end of this section.

Visualization

LED display:

- Green
- Yellow
- Red



Protection class IP66

The programmable color change allows the display of colors yellow and green to be swapped over.

Service mode

Activation of the main stroke which may be required in Aseptomag® valves with open non-actuated position for valve maintenance is performed using the service mode which can be activated by the buttons. At the same time, all feedbacks are stopped (warning to the system control). Furthermore, input signals from the control room are not implemented by the T.VIS®, in order to protect the employee.



Technical data of the standard version		
Position detection	Path measuring system	
Housing material	PA 12/L	
Ambient temperature	-20 to 60 °C	
Air supply	Pressure range	2 to 8 bar
	Standard	acc. to ISO 8573-1:2010
	Solid content	Quality class 6*
	Water content	Quality class 4
	Oil content	Quality class 3
Dimensions of air connections	Metric 6/4 mm, inch 6.35/4.31 mm (¼")	
Protection class	IP66 (powerful water jet)	
Sound pressure level via exhaust air throttle	Max. 72 dB	
Visualization	LED (green, yellow, red)	

* Recommended

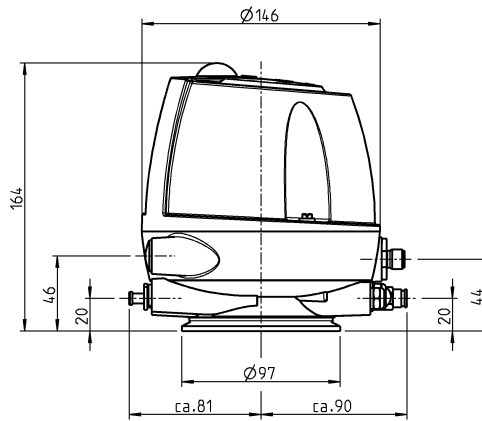

Type of interface	24 V DC, 3-wire, PNP	AS-Interface bus
Supply		
Operating voltage	24 V DC (+20 %, -12.5 %)	26.5–31.0 V DC
No-load current	≤ 25 mA	≤ 25 mA
Maximum current consumption	265 mA	65 mA*
Polarity reversal protection	Yes	Yes
Specification		AS-i V3.0 (max. 62 slaves)
Additional information		IO.ID.ID2-code: 7.A.E.
Conformity		AS-i association

Inputs		
Connection type	24 V DC (PNP)	
Short circuit-proof	Yes	
Overload-proof	Yes	
Maximum current carrying capacity per feedback output	100 mA	
Voltage drop on the outputs	≤ 1 V	
Feedback "start position"	Electronic output	Data bit DI 0
Feedback "end position"	Electronic output	Data bit DI 1
Feedback "seat lift position"	Electronic output	Data bit DI 2

Outputs		
Activation voltage	> 13 V = high; < 6 V = low	
Current consumption per input	< 10 mA	
Activation "PV Y1"	Electronic input	Data bit DO 0
Activation "PV Y2"	Electronic input	Data bit DO 1
Activation "PV Y3"	Electronic input	Data bit DO 2

* This value is valid only with an activated solenoid valve.

Switch bars and adapters

The following components are required for installation of a control and feedback system on an Aseptomag® valve pig retention cylinder.

If a complete control and feedback system is ordered, switch bar 221-589.87 or 221-589.88 is already included.

Valve type	Control top		
	T.VIS® M-15	T.VIS® A-15	
Aseptomag®	Switch bar/add-on parts		
Single-seat valves AF, AV, AVBS, GD, UV	Switch bar	221-589.87	221-589.88
	Mounting kit	0984.00038	0984.00038
Mixproof valves ADV, AXV, DK, DKBS, DDK, DT, LV	Switch bar	221-589.87	221-589.88
	Mounting kit	0984.00038	0984.00038



Switch bar 221-589.87 for T.VIS® M-15



Switch bar 221-589.88 for T.VIS® A-15

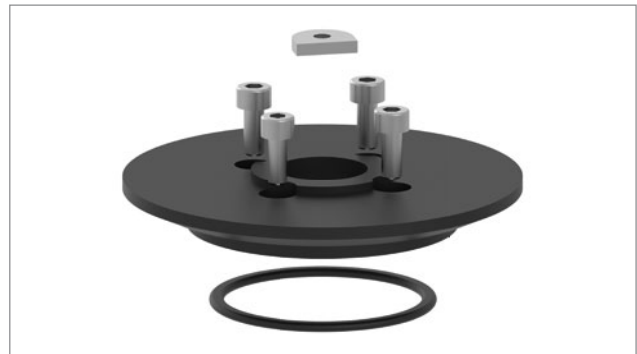

Mounting kit 0984.00038 for T.VIS® M-15 / A-15



Installation on a valve

The installation of a T.VIS® on an Aseptomag® valve is achieved by using a mounting kit. The following procedure has to be executed:

- 1 Place adaptor plate with o-ring on the pneumatic actuator and tighten it with the four bolts.
- 2 Mount switch bar on piston rod and tighten it with a wrench.
- 3 Place control top on the adaptor plate and tighten the two together by using the clamp.

With Aseptomag® valves all air tubes are connected externally. By orienting the control top, it must be considered that the air tubes are free of kinks and as short as possible.

Logic NOT-element

T.VIS® A-15 and T.VIS® M-15 control tops can optionally be equipped with a logic NOT-element. It simplifies wiring with optionally available automatic air support of the spring chamber in the actuator in order to increase the locking force of the valve, thus ensuring that it remains closed even at high product pressures, for example.

The logic NOT-element is linked to the solenoid valve Y1 (main stroke) of the particular control top and automatically channels the air supply to the spring side of the actuator as soon as solenoid valve Y1 for the main stroke is deactivated.

The pneumatic operating method of the logic NOT-element means there is no additional control complexity. In order for the logic NOT-element to be used, it is necessary for the installed actuator to be equipped with an air connection on the spring side.

To order a control top with logic NOT-element, select the following option in the order code under “control top type”:

- V – 1 solenoid valve and a NOT-element

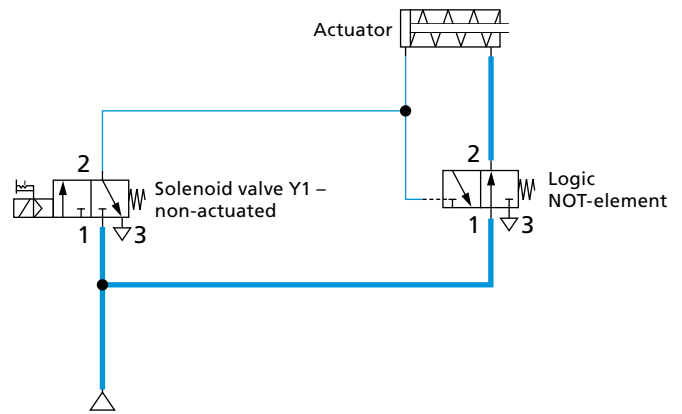

When the solenoid valve is closed, the logic NOT-element automatically directs the supporting air supply to the spring side of the actuator.

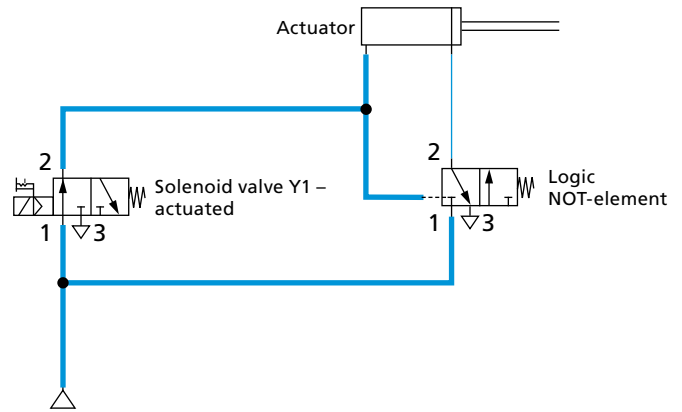

Activating the solenoid valve also activates the logic NOT-element pneumatically. The spring chamber is opened to the atmosphere and depressurized, causing the main stroke to take place.

LEFF® function

LEFF® stands for Low Emission Flip Flop. The function describes modulation of the valve disc during the lifting procedure which is monitored by the path measuring system and the electronics of the T.VIS® A-15, and works independently from the process run times and product pressures.

The LEFF® function is automatically integrated in the T.VIS® A-15 and in double-seat valves it only uses the feedback units provided as standard, without needing any special components. The straightforward configuration using two push buttons on the T.VIS® cap allows the LEFF® function to be activated separately at any time during set-up for the valve or double disc. To allow the LEFF® function to be used with the double disc, it is necessary to have the optional external proximity switch.

Modulation of the valve disc during lifting makes it possible to reduce cleaning agent consumption and/or discharge into the drains by more than 90% compared to the conventional lifting method, thereby drastically reducing operating costs. Even compared to modulation controlled in the PLC, the T.VIS® A-15 offers markedly lower CIP losses per cycle because of the significantly shorter data pathways, as well as the ability to register disc movement sooner internally because of the measuring system. Savings in the range from 30% to 80% are possible. However, these values are highly dependent on the process parameters, the level of contamination as well as the cleaning pressure and flow rate, as a result of which each CIP situation must be considered on a case-by-case basis.

Features
No complicated programming required in the PLC
No additional system technology required
Independent from process run times and product pressures
Automatic monitoring of the lift functions
Significant cost reduction (CIP medium losses, waste water costs, etc.)

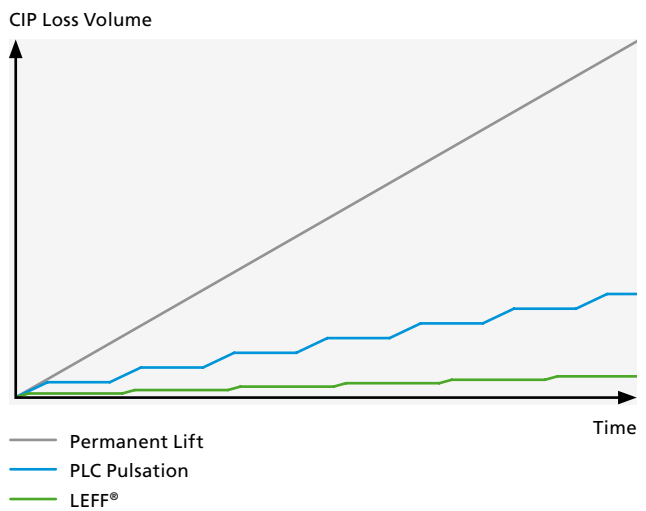

Semi-automatic setup



By means of the semi-automatic setup, a control top can be replaced without interrupting the current process.

For this, an employee only needs to perform the simple configuration once on site: in the version in protection class IP66 with two push buttons on the T.VIS® cap, and for the optional protection classes IP67 and IP69k with the cap removed right with the two buttons below.

For the semi-automatic set-up, the control top initially only learns the position of the valve disc on the non-actuated position and then remains until the valve is actuated in the scope of a running process. Only then will the end position of the valve be stored. The process thus does not need to be stopped!

The semi-automatic set-up is integrated into the T.VIS® A-15 as standard and does not require any additional hardware.

Connection Screw Fitting

	Order code for air connection		In conjunction with screw fitting or plug	Use	Matching connection socket		
	Metric	Inch			Option	Item no.	Designation
	M		M20×1,5 cable gland	T.VIS® M-15 T.VIS® A-15	-	-	-
	E		Pg 13.5 cable gland	SES	-	-	-
		Z	0.5" NPT cable gland	T.VIS® M-15 T.VIS® A-15	-	-	-
		N	Pg 13.5 cable gland	SES	-	-	-
	A	S	M20×1.5 cable gland with connection box on cable 1 m	T.VIS® M-15 (AS-i)	-	-	-
	L	U	2-pin M12 plug (A-coded)	T.VIS® M-15 (AS-i)	/22	508-963	5-pin M12-connection socket (A-coded)
					/81	508-027	AS-i connection box on cable 1 m with 5-pin M12 connection socket (A-coded)
					/82	508-028	AS-i connection box on cable 2 m with 5-pin M12 connection socket (A-coded)
	D	K	5-pin M12 plug (A-coded)	T.VIS® M-15 (DeviceNet)	/22	508-963	5-pin M12-connection socket (A-coded)
			5-pin M12 plug (B-coded)	T.VIS® M-15 (DeviceNet)		508-964	5-pin M12-connection socket (B-coded)
	J	P	5-pin M12 plug (A-coded)	T.VIS® M-15 (24 V DC) T.VIS® M-15 (48–130 V AC)	/22	508-963	5-pin M12-connection socket (A-coded)
				T.VIS® A-15 (24 V DC) T.VIS® A-15 (AS-i) T.VIS® A-15 (DeviceNet)			
				T.VIS® P-15			
			5-pin M12 plug (B-coded)	T.VIS® P-15		508-964	5-pin M12-connection socket (B-coded)
	H	I	8-pin M12 plug (A-coded)	T.VIS® M-15 (24 V DC) T.VIS® M-15 (48–130 V AC)	/22	508-061	8-pin M12-connection socket (A-coded)
				T.VIS® A-15 (24 V DC)			
		B	Brad Harrison 0.5" NPT 5-pin plug	T.VIS® M-15 (24 V DC) T.VIS® M-15 (48–130 V AC)	-	-	-

24 V (PNP/NPN)

In 24 V parallel wiring digital signals are exchanged between a terminal unit and generally the corresponding input and output modules of a PLC. In this case, it is necessary to have a separate wire for each signal, usually in the form of a multi-core cable.

PNP (current-supplying) indicates signal transfer against reference potential L₋.

NPN (current-drawing) indicates signal transfer against reference potential L₊.

BUS AS-Interface



AS-Interface (Actuator-Sensor Interface) is a standard in fieldbus communication that was developed for connecting actuators and sensors. This is to replace parallel wiring used in the past. The AS-Interface has been an international standard acc. to EN 50295 and IEC 62026-2 since 1999. AS-i products are certified by the AS International Association, thereby ensuring that equipment from different manufacturers will work together in the same system. The transmission medium is an unshielded, two-core yellow cable which also carries the electrical power supply (24 – 30 V direct current voltage) for the communication electronics and the slaves. A maximum of 62 slaves can be used per AS-i master. The slaves are addressed manually using a manual addressing unit or automatically by the master. The maximum length of the AS-i cable is 100 m, although by using repeaters it is possible to extend the entire length up to 400 m.

DeviceNet bus

DeviceNet is a CAN-based fieldbus that is chiefly used in automation engineering. DeviceNet was developed by Allen-Bradley (part of Rockwell Automation) and later transferred to the ODVA (Open DeviceNet Vendor Association) as an open standard. DeviceNet is chiefly used in the USA and, to a certain extent, Asia. A maximum of 64 network nodes can be used per fieldbus segment. The nodes address is set either using dial or DIP switches on the device, or can be configured using the bus on the basis of software. The maximum length of the DeviceNet cable depends on the selected cable type and baud rate, although it cannot exceed 500 m.

48–130 V AC

This is also parallel wiring but with alternating current voltage signals that are processed in the control top using a wide-band I/O module. This communication technology is chiefly used in the United States and Canada with 110 V, although it can also be encountered in southern Europe with 48 V.

IP Protection Classes

The IP protection classes inform about the scope at which the housing of an electrical device is protected against percolation of foreign bodies (first number) and moisture (second number).

The protected systems are assigned IP-codes. The index figures represent common error options against which the system is protected. The code starts with the letters IP for "International Protection".

Meaning of the index numbers

1. Index*	Protection from foreign bodies
6	Dust-tight
2. Index*	Protection from moisture
6	Protection from powerful water jet
7	Protection from temporary immersion
9k	Protection from water at high-pressure spray down/ high pressure steam jet cleaning

* Further indices and more precise explanations can be found in the corresponding standard.

If an index number is not stated, it is replaced by the letter x (e.g. IPx6)

For the 2nd index figure (protection from moisture), the following applies:

- The protection class IPx6 includes all indices of protection class below.
- **This does not apply to the higher protection class IPx7.** If this protection class is to include a lower protection class, this is indicated by a combination of index figures (e.g. IP67/69k).

The TVIS® control top designs of the M-15, A-15 and P-15 comply with the requirements of protection class IP66 (DIN EN 60529) as standard. Designs in the stronger protection classes IP67 or IP69k (both DIN EN 60529) are also available.



We live our values.

Excellence • Passion • Integrity • Responsibility • GEA-versity

GEA Group is a global engineering company with multi-billion euro sales and operations in more than 50 countries. Founded in 1881, the company is one of the largest providers of innovative equipment and process technology. GEA Group is listed in the STOXX® Europe 600 Index.

GEA Switzerland

GEA Aseptomag AG

Industrie Neuhof 28

3422 Kirchberg, Switzerland

Tel +41 34 4262929

Fax +41 34 4262928

flowcomponents@gea.com

gea.com