

Recommended Barriers

Recommended Barriers for Use with Burkert's Intrinsically Safe Solenoid Valves

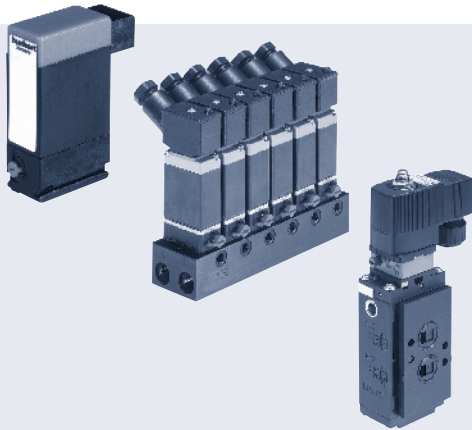

Picture showing 3 examples of intrinsically safe valve systems

- EXi solenoid valve solutions
- PTB EEx ia IIC T5 and T6 approved for Europe
- FM IS / I, II, III / ABCDEFG approved for USA

DTS 1000082649 EN Version: B Status: RL (released | freigegeben | validé) printed: 26.03.2021

Burkert offers a wide range of intrinsically safe solutions for use in hazardous areas. For the power supply of these products an approved barrier is required. This data sheet gives you an overview of approved solutions.

Applications

- Chemical industry
- Pharmaceutical processing equipment
- Industrial waste water treatment
- Oil and gas industry

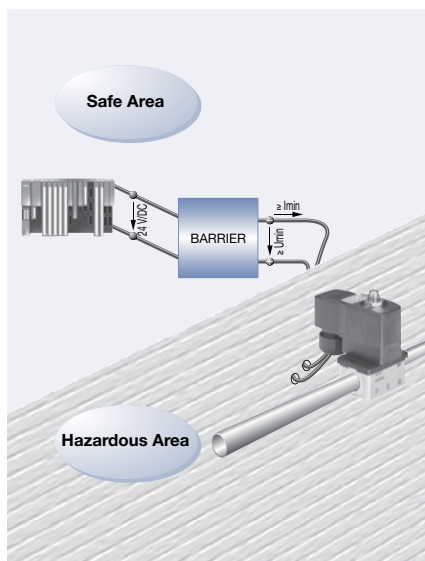

Recommended Barriers

List of approved barriers

Following barriers are tested for use with our EExi valves in Zone 1

Supplier	Type	Max. Resistance at 55°C
Bartec	Modex 07-7311-93M6/P060	144 Ω
	19-100.2801/1010	163 Ω
CEAG	SB-0728	100 Ω
	SB-1728	100 Ω
	6/915-7	70 Ω
	7/915-7	70 Ω
	2/915-7	70 Ω
	4/915-7	70 Ω
	5/915-7	70 Ω
	LB 2112	154 Ω
FB 2112	154 Ω	
Hima	F3328 (Characteristics A or C)	140 Ω
H & B	V17132-55	273 Ω
	V17332-61	200 Ω
MTL	728	140 Ω
	4021	154 Ω
	4728	110 Ω
	7028+	108 Ω
	7028-	108 Ω
	4025	93 Ω
	5025	68 Ω
	8215-DO-IS	195 Ω
P & F	KFD2-SD-Ex1.48	97 Ω
	KFD2-SL-Ex1.48	97 Ω
	KFD2-SD-Ex1.48.90A	97 Ω
	KFD2-SL-Ex1.48.90A	97 Ω
	Z 728	140 Ω
	Z 828	140 Ω
	Z 728.CL	140 Ω
	Z 828.CL	140 Ω
	KSD2-BO-Ex	173 Ω
	RSD-BO-Ex4	106 Ω
	VAA-2EA-G5-N/V1-Ex	203 Ω
	EGA-041-3	120 Ω
ED2-VD-Ex.2.1835	160 Ω	
Phoenix Contact	PI/Ex-SD/22/45-C	191 Ω
Steel	9351/10-16-10	163 Ω
	9151/10-16-10	193 Ω
	9475/12-04-21	144 Ω
	9475/12-04-31	82 Ω
	9475/12-08-51	54 Ω
	9651/40-16-10	233 Ω
	9001/01-280-100-10	138 Ω
	9001/01-252-100-14	182 Ω
Turck	MC 72-41Ex-T	157 Ω
	MC 72-43Ex-T	157 Ω

Please contact your Burkert representative if your preferred barrier is not on this list.

Technical data – coil AC10 EExi

Approved to:
PTB EEx ia IIC T6, T5
FM IS / I, II, III / ABCDEFG

Values for switching function	at 68°F	at 131°F
Min. switching current (≥ 14.5 PSI)	29 mA	29 mA
Nominal resistance coil	310 Ω	360 Ω
Minimum terminal voltage	9.0 V	10.4 V

Example of max. allowable combinations acc. to certificate of conformity	
U _i	28 V
I _i	120 mA
P _i	1.1 W
T amb max.	140°F ^(T6) 167°F ^(T5)

Coil used in following
Burkert valves:

- 0590 EExi
- 0590 NAMUR EExi
- 6013 EExi
- 6014 EExi
- 6518 EExi
- 6519 EExi
- 6519 NAMUR EExi

Technical data – coil AC21 EExi

Approved to:
PTB EEx ia IIC T6, T5
FM IS / I, II, III / ABCDEFG

Values for switching function	at 68°F	at 131°F
Min. switching current (≥ 14.5 PSI)	29 mA	29 mA
Nominal resistance coil	320 Ω	360 Ω
Minimum terminal voltage	9.3 V	10.4 V

Example of max. allowable combinations acc. to certificate of conformity	
U _i	28 V
I _i	120 mA
P _i /T amb max (block assembly)	0.7 W / 122°F ^(T6)
P _i /T amb max (block assembly)	0.9 W / 140°F ^(T5)
P _i /T amb max (single mounting)	0.9 W / 131°F ^(T6)
P _i /T amb max (single mounting)	0.9 W / 158°F ^(T5)

Coil used in following
Burkert valves:

- 0450 EExi
- 5470 M EExi
- 5470 NAMUR EExi
- 6106 EExi
- 6516 EExi
- 6517 EExi
- 8640 EExi*

(*if used with 0450 EExi and 5470 M EExi)

Technical data – coil AC6104 EExi

Approved to:
PTB EEx ia IIC T6, T5
FM IS / I, II, III / ABCDEFG

Values for switching function	at 68°F	at 131°F
Min. switching current (≥ 14.5 PSI)	29 mA	29 mA
Nominal resistance coil	320 Ω	360 Ω
Minimum terminal voltage	9.3 V	10.4 V

Example of max. allowable combinations acc. to certificate of conformity	
U _i	28 V
I _i	120 mA
P _i /T amb max (block assembly)	0.5 W / 104°F ^(T6)
P _i /T amb max (block assembly)	0.6 W / 122°F ^(T5)
P _i /T amb max (single mounting)	0.5 W / 122°F ^(T6)
P _i /T amb max (single mounting)	0.7 W / 140°F ^(T5)

Coil used in following
Burkert valves:

- 6104 EExi
- 6510 EExi
- 6511 EExi

DTS 1000082649 EN Version: B Status: RL (released | freigegeben | validé) printed: 26.03.2021

Recommended Barriers

DTS 1000082649 EN Version: B Status: RL (released | freigegeben | validé) printed: 26.03.2021

In case of special application conditions,
please consult for advice.

We reserve the right to make technical
changes without notice.

0602/2_US-en