



3/2-way or 2 x 3/2-way solenoid valve for pneumatic applications

- Compact design
- Second connection for shut-off function
- Low power consumption
- Fast switching times



Product variants described in the data sheet may differ from the product presentation and description.

Can be combined with

- 
Type 8640 ▶
Modular valve island for pneumatics
- 
Type 8644 ▶
Remote Process Actuation Control System AirLINE
- 
Type MKRS ▶
Redundancy valve block for safety related shut-off function
- 
Type 8647 ▶
AirLINE SP – electro-pneumatic automation system
- 
Type 2505 ▶
10 mm socket for Bürkert small solenoid valves

Type description

Type 6524 consists of a pilot flipper solenoid valve Type 6144 and a pneumatic seat valve. The flipper action system allows the switching of high pressures combined with low power consumption and short switching times. All the valves are equipped with manual override as standard. The 2 x 3/2-way valve variant is a combination of two pilot flipper solenoid valves Type 6144 and one pneumatic seat valve. The valve is also available with a second connection (press-fit cable), which makes a safe shut-off function possible.

DTS 1000021454 EN Version: P Status: RL (released | freigegeben | valide) printed: 16.05.2022

Table of contents

1. General technical data	3
2. Circuit functions	4
3. Dimensions	5
3.1. Standard version 3/2 way	5
3.2. Standard version 2 x 3/2 way	5
3.3. Second connection for shut-off function 3/2 way	6
3.4. Second connection for shut-off function 2 x 3/2 way	6
4. Product design and assembly	7
4.1. Product assembly	7
Standard version 3/2 way	7
Standard version 2 x 3/2 way	7
4.2. Distinguishing features valve revisions	8
5. Ordering information	8
5.1. Bürkert eShop – Easy ordering and quick delivery	8
5.2. Bürkert product filter	9
5.3. Ordering chart standard version	9
5.4. Ordering chart second connection shut-off function	10
5.5. Ordering chart accessories	10

1. General technical data

Circuit functions	3/2 way valve	2 × 3/2 way valve
Product properties		
Dimensions	Detailed information can be found in chapter “3. Dimensions” on page 5.	
Material		
Seal	FKM, NBR and PUR	
Body	PPS, PA	
Weight	20 g	40 g
Manual override	Standard	
Orifice	DN 4.0	
Pneumatic module	With plug-in coupling, Ø 6 mm, Ø ¼“	
Circuit function	C and D Detailed information can be found in chapter “2. Circuit functions” on page 4.	
Performance data		
Nominal operating mode	Continuous operation (100 % ED)	
Switching frequency	Approx. 1000 c.p.m.	
Switching time ^{1.)}	Opening: < 10 ms Closing: < 10 ms	
Electrical data		
Operating voltage	24 V DC ^{2.)}	
Nominal power	0.8 W	2 × 0.8 W
Voltage tolerance	± 10 %	
Medium data		
Operating medium	Lubricated, oil-free, dry compressed air, neutral gases (5 µm filter recommended)	
Medium temperature	- 10 °C...+50 °C	
Process/Port connection & communication		
Electrical connection	Rectangular plug with 2 pins, raster 5.08 mm	Rectangular plug with 3, pins raster 2.54 mm
Approvals and certificates		
Degree of protection	IP40 with rectangular plug	
Protection class	3 acc. to VDE 0580	
Environment and installation		
Installation position	As required, preferably with actuator upright	
Mounting	With 2 screws M2 x 20	With 2 screws M2 x 28
Ambient temperature	- 10 °C...+55 °C	

1.) Measurement acc. to ISO 12238

2.) 10 % residual ripple allowed

2. Circuit functions

Circuit functions	Description
	Type: C, solenoid valve 3/2 way Servo-controlled, with manual mode Normally closed
	Type: C, solenoid valve 2 x 3/2 way Servo-controlled, with manual mode Normally closed
	Type: C, solenoid valve 3/2 way Servo-controlled Normally closed
	Type: C, solenoid valve 3/2 way Servo-controlled Normally closed
	Type: D, solenoid valve 3/2 way Servo-controlled, with manual mode Normally open
	Type: D, solenoid valve 3/2 way Servo-controlled Normally open

3. Dimensions

3.1. Standard version 3/2 way

Note:

- For Type 6524, 3/2 way, a standardisation of the pneumatic flange pattern has been made.
- There is a difference in the versions of the flange patterns. The external dimensions remain identical.
- Dimensions in mm

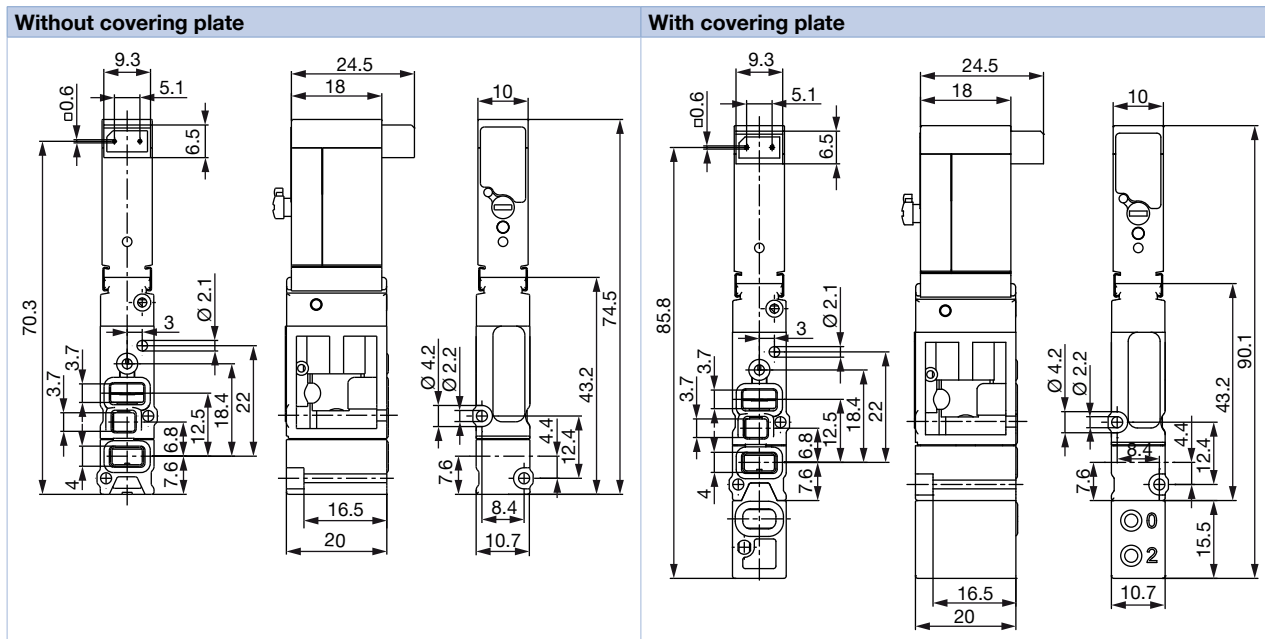

3.2. Standard version 2 x 3/2 way

Note:

Dimensions in mm

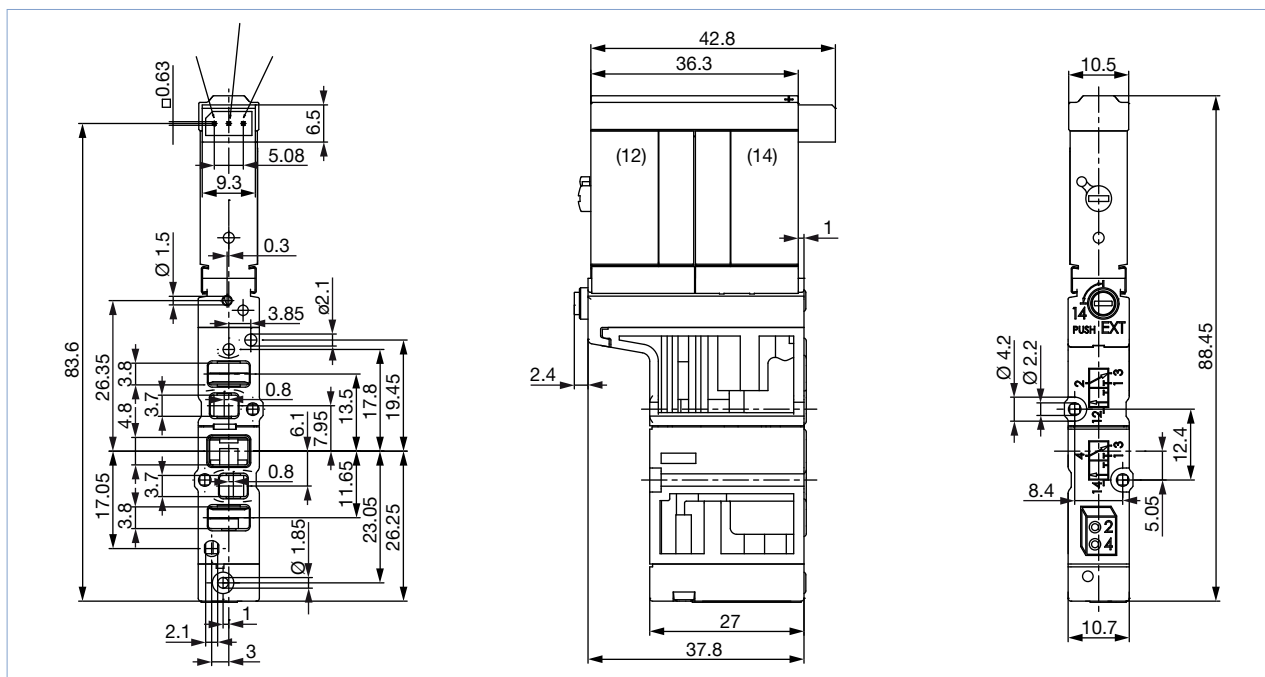

DTS 1000021454 EN Version: P Status: RL (released | freigegeben | valide) printed: 16.05.2022

3.3. Second connection for shut-off function 3/2 way

Note:

- For Type 6524, 3/2 way, a standardisation of the pneumatic flange pattern has been made.
- There is a difference in the versions of the flange patterns. The external dimensions remain identical.
- Dimensions in mm

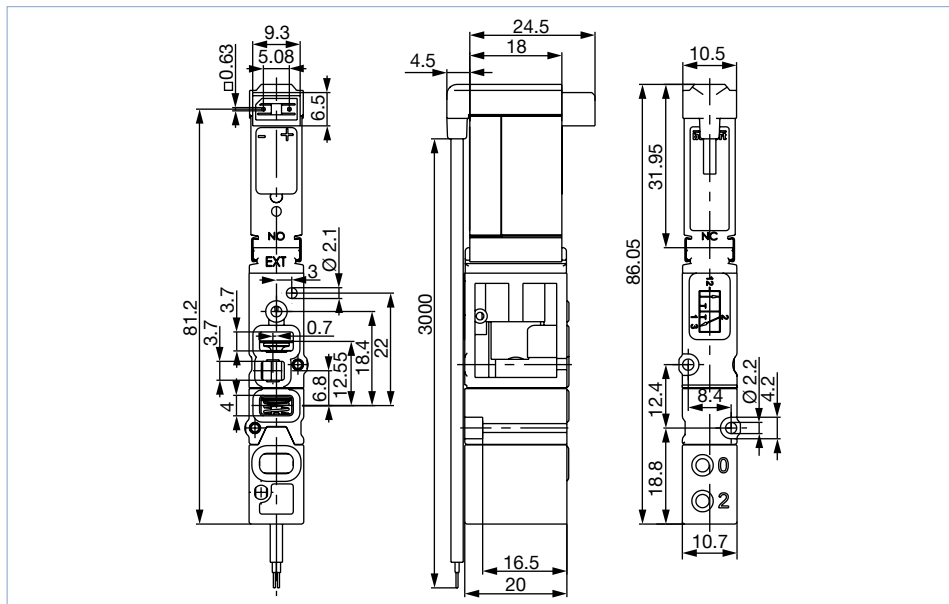

3.4. Second connection for shut-off function 2 x 3/2 way

Note:

Dimensions in mm

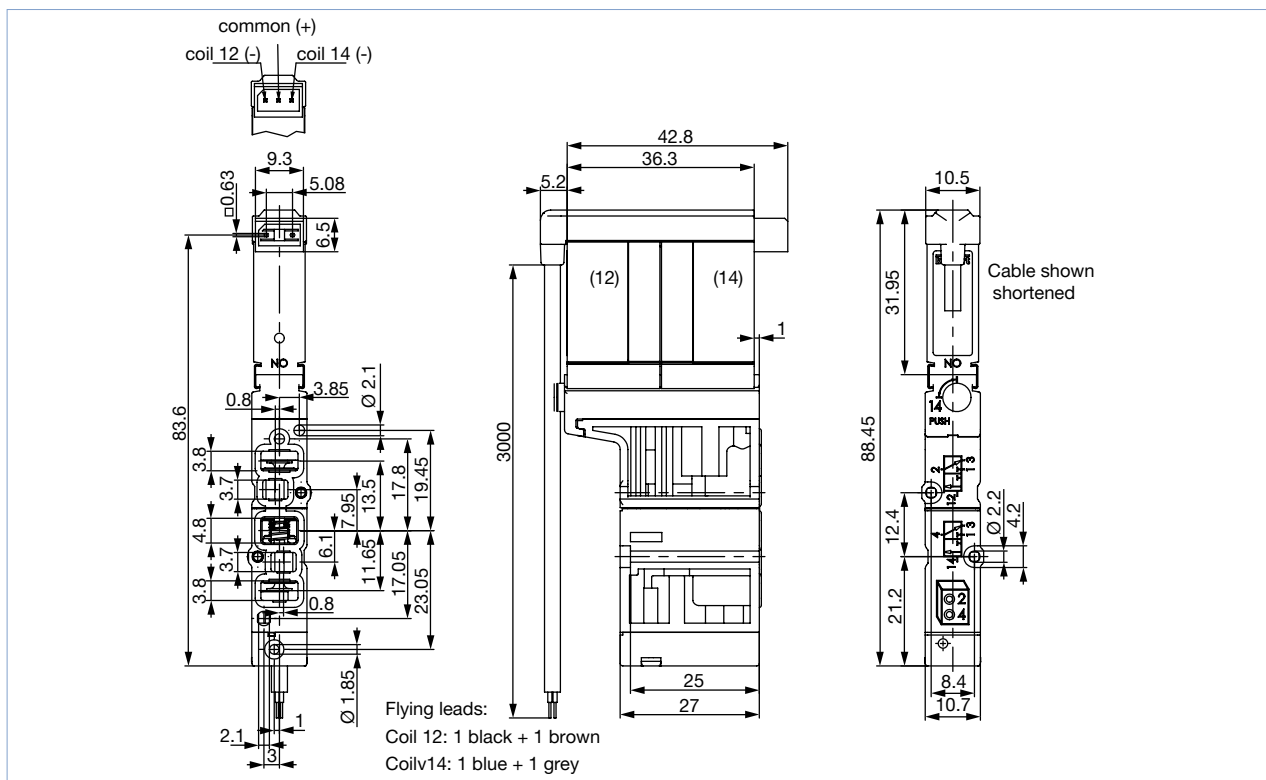

DTS 1000021454 EN Version: P Status: RL (released | freigegeben | valide) printed: 16.05.2022

4. Product design and assembly

4.1. Product assembly

Standard version 3/2 way

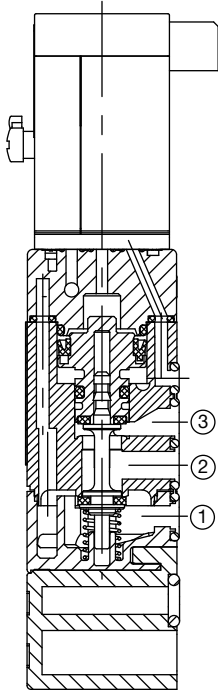
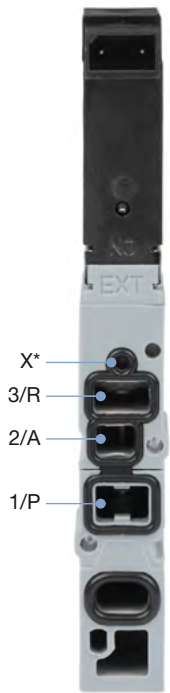
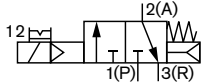
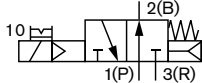
Sectional drawing Pilot control Type 6144	Connection overview	Circuit function
		<p>C</p>  <p>D</p> 

Standard version 2 x 3/2 way

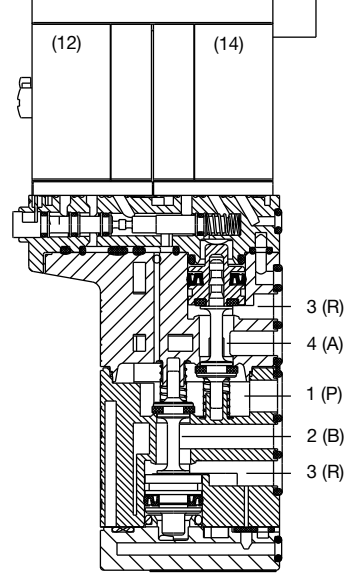
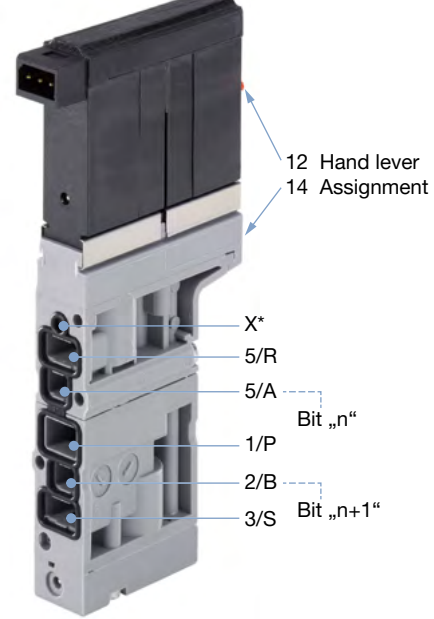
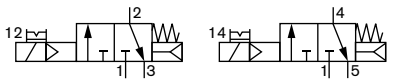
Sectional drawing	Connection overview	Circuit function
		<p>C 2 x 3/2 way valve</p> 

4.2. Distinguishing features valve revisions

Note:

- For type 6524, 3/2-way, the pneumatic flange pattern has been standardised.
- There is a difference in the versions of the flange patterns (Rev. 1/Rev. 2). The external dimensions remain identical.
- Before the pneumatic installation, the compatibility with the present valve terminal must be checked (see operating instructions of the corresponding valve terminal).

The valve revisions can be distinguished by the following features:

Valves 6524	Valve REV. 1	Valve REV. 2
Article no.	Distinguishing by Article no. see "5. Ordering information" on page 8	
Visual distinction	<p>REV. 1 Single valves Type 6524 and Type 6525 with flange interface „FM14“</p> <p>Different size of the channels</p> <p>REV. 2 Single valves Type 6524 and Type 6525 with flange interface „FM20“</p>	
Information label	There is a corresponding information label on the relevant valve which indicates that the valve has been overhauled. This information label must be removed before assembly.	
Compatibility with the pneumatic modules of the island by means of the working ports	<p>black parallel</p>	<p>blue wavy</p>

5. Ordering information

5.1. Bürkert eShop – Easy ordering and quick delivery



Bürkert eShop – Easy ordering and fast delivery

You want to find your desired Bürkert product or spare part quickly and order directly? Our online shop is available for you 24/7. Sign up and enjoy all the benefits.

Order online now

DTS 1000021454 EN Version: P Status: RL (released | freigegeben | validé) printed: 16.05.2022

5.2. Bürkert product filter



Bürkert product filter – Get quickly to the right product



You want to select products comfortably based on your technical requirements? Use the Bürkert product filter and find suitable articles for your application quickly and easily.

[Try out our product filter](#)

5.3. Ordering chart standard version

Hinweis:

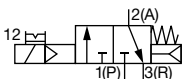
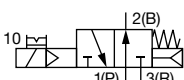
- For Type 6524, 3/2 way, a standardisation of the pneumatic flange pattern has been made.
- There is a difference in the versions of the flange patterns (Rev. 1/Rev. 2). The external dimensions remain identical.
- Before the pneumatic installation, the compatibility with the present valve island must be checked (see operating instructions of the corresponding valve island).

Circuit function	Orifice [mm]	Q _{Nn} value air [l/min] ^{1.)}	Pressure range [bar] ^{2.)}	Voltage/ Frequency [V/Hz]	Integrat- ed power savings electronics	Article no.	
						Ventile REV. 1	Ventile REV. 2
3/2 way							
C, solenoid valve 3/2 way Servo-controlled, with manual mode Normally closed 	4	300	Vac....10 ^{3.)}	24 V DC ^{4.)}	–	20029915	20029923
			1...10	24 V DC ^{4.)}	–	20029913	20029921
			2.5...10	24 V DC ^{4.)}	–	20029910	20029918
D, solenoid valve 3/2 way Servo-controlled, with manual mode Normally open 	4	300	2.5...10	24 V DC ^{4.)}	–	20029911	20029919
2 x 3/2 way							
C, solenoid valve 2 x 3/2 way Servo-controlled, with manual mode Normally closed 	4	300	1...10 ^{3.)}	24 V DC ^{4.)}	Yes ^{5.)}	186259	
			2.5...10	24 V DC ^{4.)}	Yes ^{5.)}	186260	
			2.5...10	24 V DC ^{4.)}	No	204710	

1.) Measured at +20 °C, 6 bar pressure at valve inlet and 1 bar pressure difference

2.) Measured as overpressure to the atmospheric pressure

3.) Version with auxiliary pilot air

4.) 10 % residual ripple allowed

5.) Applicable on valve island Type 8640, AirLINE system Type 8644 or valve blocks

6.) The valve article number can no longer be ordered. Please order superior set.

5.4. Ordering chart second connection shut-off function

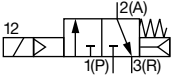
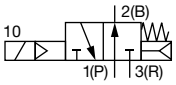
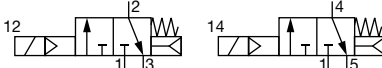
Circuit function	Orifice	Q _{Nn} value air	Pressure range	Voltage/ Frequency	Integrat- ed power savings electronics	Article no.	
	[mm]	[l/min] ^{1.)}	[bar] ^{2.)}	[V/Hz]			
3/2 way, without manual override							
C, solenoid valve 3/2 way Servo-controlled Normally closed 	4	300	Vac...10 ^{3.)}	24 V DC ^{4.)}	–	on request	on request
			1...10	24 V DC ^{4.)}	–	on request	on request
			2.5...10	24 V DC ^{4.)}	–	20029916 ☒ (285545) ^{6.)}	20029924 ☒ (20013136) ^{6.)}
D, solenoid valve 3/2 way Servo-controlled Normally open 	4	300	2.5...10	24 V DC ^{4.)}	–	on request	on request
2 x 3/2 way, without manual override							
C, solenoid valve 3/2 way Servo-controlled Normally closed 	4	300	1...10 ^{3.)}	24 V DC ^{4.)}	Yes ^{5.)}	on request	
			2.5...10	24 V DC ^{4.)}	Yes ^{5.)}	285547 ☒	
			2.5...10	24 V DC ^{4.)}	No	300818 ☒	

1.) Measured at +20 °C, 6 bar pressure at valve inlet and 1 bar pressure difference

2.) Measured as overpressure to the atmospheric pressure

3.) Version with auxiliary pilot air

4.) 10 % residual ripple allowed

5.) Applicable on valve island Type 8640, AirLINE system Type 8644 or valve blocks

6.) The valve article number can no longer be ordered. Please order superior set.

5.5. Ordering chart accessories

Accessories	Version	Features	Article no.
Rectangular cable plug for Type 6524 single valve	Raster 5.08 mm	With 3 m cable, 2-pins	133486 ☒
		With 300 mm flying leads, 2-pins	644068 ☒
		With 2 single contacts	644067 ☒
Covering plate for 5/2 way valve position	Complete	For 1 unused valve position	650373 ☒
Covering plate for 2 x 3/2 way valve position		For 1 unused valve position	661092 ☒
Set of profile seal 2x 3/2-way	For REV. 1/2	12 seals	20016305 ☒
Set of profile seal 3/2-way	For REV. 1	12 seals	20024333 ☒
Set of profile seal 3/2-way	For REV. 2	12 seals	20024336 ☒

Bürkert – Close to You

For up-to-date addresses
please visit us at
www.burkert.com

DTS 1000021454 EN Version: P Status: RL (released | freigegeben | validé) printed: 16.05.2022

