

Dependable Service for Tank and Kettle Applications

762 Tank and Kettle Valves

PD 66364 US1 2001-10

Application

This air-operated tank outlet valve features the positive action of either a short-stroke or long-stroke actuator. The 762 valve is ideal for high volume, sanitary liquid processing applications. It's heavy-duty construction and precision-molded bonnet gaskets ensure positive alignment under severe operating conditions. The 762 valve has a sanitary and flexible design allowing it to be used in a wide range of applications.

Working principle

The valve is remote-controlled by means of compressed air. It has few and simple moveable parts which results in a very reliable valve.

Standard design

The 762 series valves are designed to deliver years of reliable performance. Rugged and long-lasting plastic stem bushings eliminate metal-to-metal galling. The stems are threaded to the actuator shaft, eliminating the coupling between the stem and the actuator, thereby ensuring proper alignment. The valve stem design requires only a single o-ring seal. And bushings at each end of the actuator cylinder support stem also ensure perfect alignment. The 762 series features a heavy-duty bonnet and body ferrule design that will stand up to years of pounding from hydraulic shock. Standard 32Ra finish on the ID.

Other valves in the same basic design:

- Tank and Kettle valves, type 262

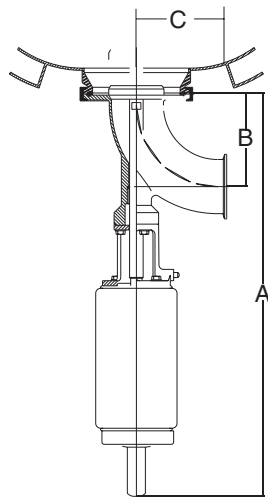
Actuator function

- Pneumatic closing, spring opening (NO).
- Pneumatic opening, spring closing (NC).
- Pneumatic opening and closing (A/A),
- Actuator for intermediate position of the valve plug as option

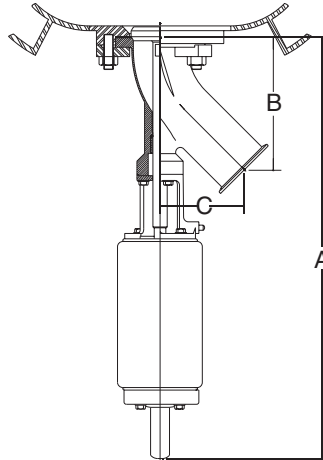


Fig. 1. 762 Kettle valve.

Dimensions



Clamp Mount
(762-31 Shown)



Flange Mount
(762-33 Shown)

Elbow Kettle Valves (Clamp Mount)

Valve Size (Tube OD)	762-21 & 762-31 90° Elbow						762-35 45° Elbow					
	A*		B		C		A*		B		C	
	in	mm	in	mm	in	mm	in	mm	in	mm	in	mm
2-inch	21	22.5	3.69	94.0	3.50	89.0	21	533.0	5.6	129.0	3.13	79.0
2½-inch	21.69	551.0	4.44	113.0	4.25	108.0	21.69	551.0	5.94	151.0	3.88	98.0
3-inch	22.19	564.0	5.19	132.0	5	127.0	22.19	564.0	7	178.0	450	114.0
4-inch	23.75	603.0	6.00	175.0	6.50	175.0	23.75	603.0	9.38	238.0	6	152.0

* For Control Housing, add 3/4" (19mm) to dimension A.
1" (25.4mm) clearance required for removal.

Elbow Kettle Valves (Flange Mount)

Valve Size (Tube OD)	762-29 90° Elbow						762-33 45° Elbow					
	A*		B		C		A*		B		C	
	in	mm	in	mm	in	mm	in	mm	in	mm	in	mm
2-inch	21.00	533.00	3.69	94.00	3.50	89.00	21.00	533.00	5.06	129.00	3.13	79.00
2½-inch	21.69	551.00	4.44	113.00	4.25	108.00	21.69	551.00	5.94	151.00	3.88	98.00
3-inch	22.19	568.00	5.19	132.00	5.00	127.00	22.38	568.00	7.00	178.00	450	114.00
4-inch	23.75	603.00	6.88	175.00	6.50	175.00	23.75	603.00	9.38	238.00	6.50	165.00

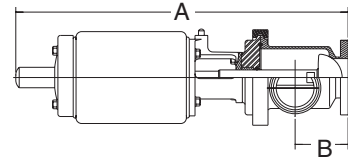
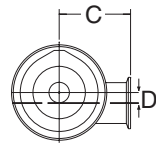
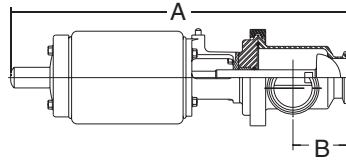
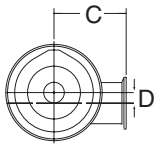
* For Control Housing, add 3/4" (19mm) to dimension A.
1" (25.4mm) clearance required for removal.

Elbow Kettle Valves are normally-closed, air-to-open — spring-to-close.

Note! Extreme caution should be used when welding ferrules or flanges to kettles to prevent distortion.

Dimensions

Tee Type and Cross Body Tangential Outlet Valves



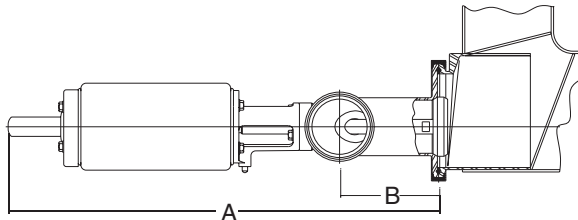
Valves with Tri-Clamp Inlet
 762-47, Right Hand Outlet 90° (shown)
 762-48, Left Hand Outlet 90°
 762-51, Cross Body

Valves with Flanged Inlet
 762-49, Right Hand Outlet 90° (shown)
 762-50, Left Hand Outlet 90°
 762-52, Cross Body

Note! To determine whether a valve is right or left hand outlet, view valve from actuator end.

Valve Size (Tube OD)	A				B		C		D	
	Short Stroke		Long Stroke		in	mm	in	mm	in	mm
	in	mm	in	mm						
2-inch	16.31	414.00	20.25	514.00	2.63	67.00	3.50	89.00	0.50	13.00
2½-inch	17.00	432.00	21.00	533.00	3.06	78.00	3.50	89.00	0.75	19.00
3-inch	17.56	446.00	21.56	548.00	3.38	89.00	3.75	95.00	0.75	19.00
4-inch	NA	NA	34.56	878.00	6.25	159.00	6.25	159.00	0.50	113.00

*Control Housing: add 3/4" (19mm) to dimension A.
 1" (25.4mm) clearance required for removal.



90° Elbow, Offset Front
 Outlet Valves
 No. 762-57, Right Hand (shown)
 No. 762-58, Left Hand
 (Outlet is horizontal)

Valve Size (Tube OD)	C		D	
	in	mm	in	mm
2-inch	21.00	533.00	3.69	94.00
2½-inch	21.69	551.00	4.44	113.00
3-inch	22.38	568.00	5.19	132.00
4-inch	23.75	603.00	6.88	175.00

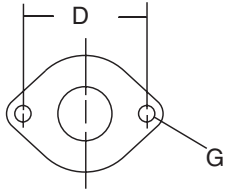
*Control Housing: add 3/4" (19mm) to dimension A.
 1" (25.4mm) clearance required for removal.

Note! To determine whether a valve is right or left hand outlet,
 view valve from actuator end.

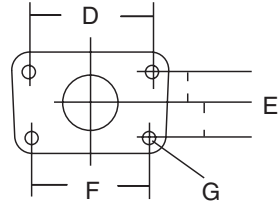
Note! Extreme caution should be used when welding ferrules or
 flanges to tanks to prevent distortion.

Dimensions

Flange Bolt Hole



2 hole flange
for 2" (51mm) valves



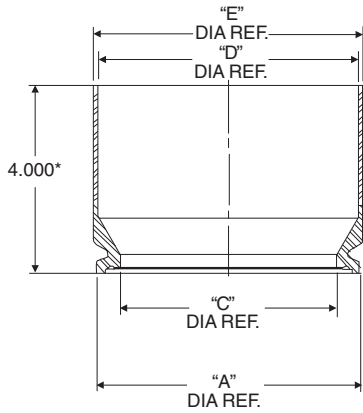
4 hole flange for
2½" (63.5mm), 3" (76mm)
and 4" (102mm) valves

Valve Size (Tube OD)	D		E		E1		F		G	
	in	mm	in	mm	in	mm	in	mm	in	mm
2-inch	4.25	108.00	NA	NA	NA	NA	NA	NA	0.50	14.00
2½-inch	5.25	133.50	1.31	33.50	1.50	38.00	5.00	127.00	0.56	14.00
3-inch	6.63	168.00	1.74	44.50	1.75	44.50	5.63	143.00	0.69	14.00
4-inch	8.63	219.00	2.94	75.00	2.94	75.00	7.50	190.50	0.81	17.50

Ferrule Part Numbers

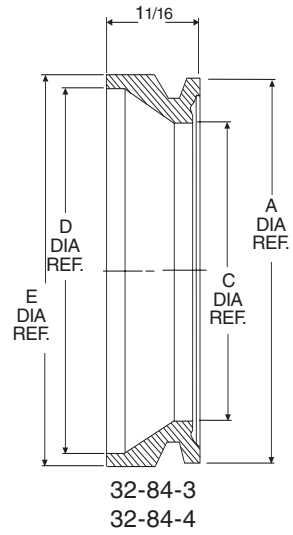
Valve Model	Ferrule	Valve Only-Less Ferrule
762-21-Size	32-82-3	762-20-2" & 2.5"
	32-82-4	762-20-3" & 4"
762-31-Size	32-84-3	762-20-2" & 2.5"
	32-84-4	762-20-3" & 4"
762-29-Size	32-121	762-28-2" & 2.5" & 3"
	32-180	762-28-4"
762-57-Size	32-154	762-55-2" & 2.5"
	32-595	762-55-3" & 4"
762-58-Size	32-154	762-56-2" & 2.5"
	32-595	762-56-3" & 4"
762-35-Size	32-84-3	762-24-2" & 2.5"
	32-84-4	762-24-3" & 4"
762-33-Size	32-121	762-32-2" & 2.5" & 3"
	32-180	762-32-4"

Dimensions
Tank Pods for Kettle Valves



*4" length is standard. Other lengths available per customer requirement.

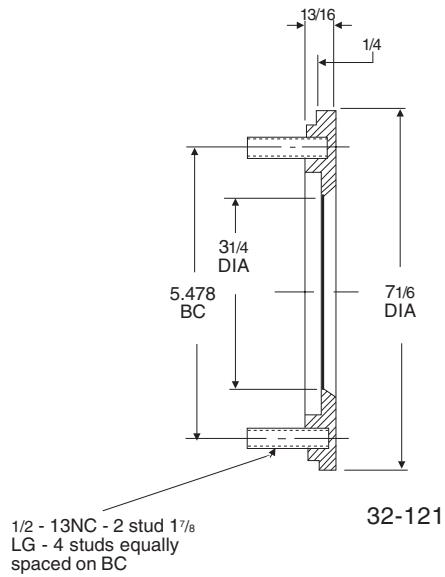
32-82-3
32-82-4



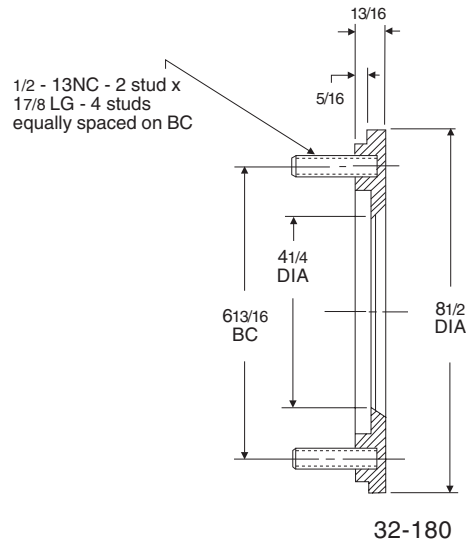
32-84-3
32-84-4

Sizes 32-82 and 32-84

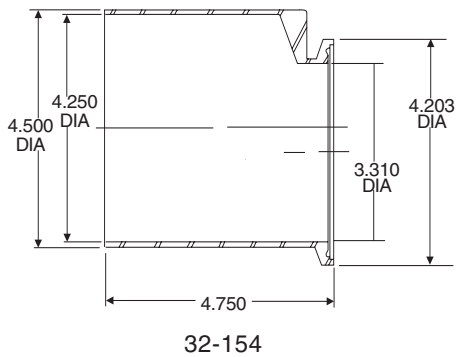
Valve Size	A in	C in	D in	E in
3-inch	4.20	3.31	4.25	4.50
4-inch	5.87	4.84	5.78	6.00



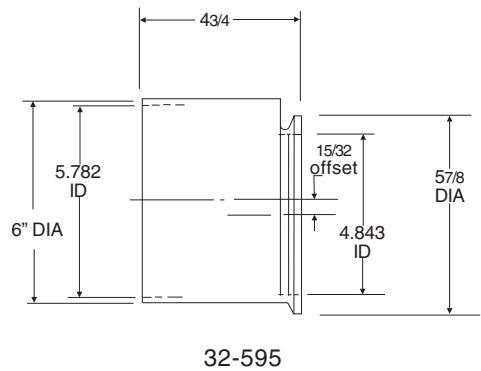
32-121



32-180



32-154



32-595

Actuators

Type 20 (Normally-Closed)

Shut-off valve holding pressures (Standard)**

Short Stroke Actuator (Standard*)				Long Stroke Actuator (Standard*)		
Size	Elastomer	"TR"	Stroke Length	Elastomer	"TR"	Stroke Length
2-inch	90 psi	90 psi	1"	90 psi	90 psi	2"
2½-inch	55 psi	55 psi	1"	60 psi	55 psi	2"
3-inch	40 psi	40 psi	1"	32 psi	25 psi	2"
4-inch	65 psi	65 psi	2"	45 psi	40 psi	4"

* 4½" diameter actuator is standard on the 1"-3" valves. A 6" diameter actuator is supplied with the 4" valve. The 6" diameter actuator is available, as a heavy duty option, for the 3" valve.

** On a standard actuator it takes 30 psi to offset the spring force when fully extended and 60 psi to fully compress the spring.

Type 20 (Normally-Closed)

Optional "HP" high pressure actuator. (6" diameter actuator)

Short Stroke Actuator (Standard*)				Long Stroke Actuator (Standard*)		
Size	Elastomer	"TR"	Stroke Length	Elastomer	"TR"	Stroke Length
2½-inch	90 psi	80 psi	1"	120 psi	110 psi	2"
3-inch	70 psi	60 psi	1"	80 psi	70 psi	2"

Actuator Air Supply Specifications

See chart below for minimum air pressure requirements. Maximum air pressure is 100 psi (normal). Air volume required is identified by the length of the stroke.

Valve Size	Stroke (in.)	Volume (cu. in.)
1½ - 3-inch short stroke	1	14.80
1½ - 3-inch long stroke	2	29.50
4-inch short stroke HP	2	50.00
4-inch long stroke HP	4	95.00

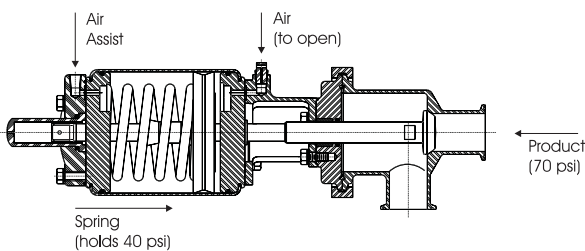
Lubricated air is not required. Filtered air and a pressure regulator valve are required.

Additional Holding Pressure

Additional air supply must be relieved when product pressure is not present. Failure to do so will result in pressure damage to the seat. When using additional air loading it should exceed the minimum required by no more that 3 to 5 psig.

Example: A customer has an application for a 3" valve that is required to hold 70 psi product pressure with an elastomer (Buna). The valve without an air assist will hold 40 psi. An additional holding force to overcome 30 psi (70 psi-40 psi) is needed. Since the ratio is 5:10 (air-to-product pressure ratio) a 15 psi air assist is needed.

Note! Since it takes 60 psi to fully stroke the valve without air assist, it will take 75 psi to open the example. (60 psi+15 psi)



Valve Size	Air to Product Pressure Ratio	Max Recommended Air Assist	Max. Product Holding Pressure
1-inch	1:10	10	200
1½-inch	1:10	5	200
2-inch	2:10	10	150
2½-inch	3:10	20	100
3-inch	5:10	35	100
4-inch HP	4:10	25	100

Technical data

Max. product pressure depends on valve specifications and size
(contact Alfa Laval)
Temperature range: 200° F to 284° F (EPDM)
Air pressure 60-80 PSI

Materials

Product wetted steel parts Stainless steel AISI 316L
Finish 32 Ra Standard
Other steel parts Stainless steel AISI 304
Plug stem Buna bonded or “TR” PTFE replaceable
Product wetted seals Buna
Process connections Tri-Clamp®

Options

Equipment

- Process connections, weld, bevel seat
- Control and indication (Control Top or *ThinkTop*®)
- High pressure actuator for 2½” and 3” size
- Three Position Actuator (80)
- 20 Ra or 15 Ra ID surface finish
- Long stroke actuator (Standard on kettle valve)

Material grades

- Industrial finish
- Plug stem materials of EPDM, SFY, or PTFE
- O-rings and seals of EPDM or SFY (Flouroelastomer)

Ordering

Please state the following when ordering:

- Size
- Connections
- Valve body combination
- Actuator function, NC, NO or A/A
- Options

PD 66364 US1 2001-10

The information contained herein is correct at the time of issue, but may be subject to change without prior notice.

How to contact Alfa Laval
Contact details for all countries
are continually updated on our website.
Please visit www.alfalaval.com to
access the information direct.

