

Type 8652 AirLINE

Modular valve island for pneumatics



Operating Instructions

We reserve the right to make technical changes without notice.

© Bürkert Werke GmbH & Co. KG, 2017 - 2024

Operating Instructions 2405/20_EUen_00810541 / Original DE

Valve island AirLINE Type 8652

CONTENTS

1	OPERATING INSTRUCTIONS	6
1.1	Symbols.....	6
1.2	Definition of terms.....	7
2	INTENDED USE	8
3	BASIC SAFETY INSTRUCTIONS	9
4	GENERAL NOTES.....	11
4.1	Contact address.....	11
4.2	Warranty	11
4.3	Information on the Internet.....	11
5	PRODUCT DESCRIPTION.....	12
5.1	Product structure	14
5.2	External safety-related shutdown of valves.....	17
6	TECHNICAL DATA	18
6.1	Standards and directives.....	18
6.2	Operating conditions	18
6.3	Pneumatic data	18
6.4	General electrical data.....	19
6.5	Electrical data of electronic module with digital inputs	20
6.6	Pneumatic slide valve type 6534.....	21
6.7	Circuit function (CF).....	22
6.8	Standard type label (example).....	23
6.9	Type label UL (example).....	23
6.10	Industrial Ethernet specifications.....	24
6.11	Specifications PROFIBUS DPV1	25
6.12	CC-Link specifications.....	26
7	INSTALLATION OF THE VALVE ISLAND IN THE CONTROL CABINET.....	27
7.1	Installation on the control cabinet floor or the control cabinet wall with AirLINE Quick.....	28
7.2	Standard rail installation	31
8	ELECTRICAL CONNECTION.....	33
8.1	Cabling of bÜS networks	33
8.2	Fieldbus gateway ME43.....	33
8.3	24 V supply voltage for pneumatic valves	37
8.4	Electronic module with digital inputs.....	38
8.5	Electrical connection assignment	39
8.6	Valves type 6534 for safety-related shutdown, variant SIA	40
8.7	Modular safety-related shutdown	42
9	PNEUMATIC CONNECTION.....	44
9.1	Assignment of the pneumatic ports.....	44
9.2	Pneumatic connection assignment.....	46
10	INTEGRATION INTO THE CONTROL ENVIRONMENT.....	47
10.1	Start-up files and description of the process data and parameters.....	47
10.2	PLC compatibility	47
10.3	Commissioning a PROFINET device with Siemens TIA Portal	49
10.4	Commissioning a PROFIBUS DPV1 device with Siemens TIA Portal.....	52
10.5	Commissioning an EtherNet/IP device with Rockwell Logix Designer	55

	10.6	Bit-wise composition of the inputs and outputs	69
	10.7	Advanced gateway functionalities	69
11		CONFIGURATION WITH WEB SERVER	70
	11.1	Establishing a connection to the web server.....	70
	11.2	Logging onto the web server.....	71
	11.3	Passwords.....	71
	11.4	Finding the device.....	71
	11.5	Disabling web server access with Bürkert Communicator	72
	11.6	Information in the web server.....	72
	11.7	Setting options in the web server	72
	11.8	Industrial communication of web server.....	73
12		CONFIGURATION WITH FIELDBUS GATEWAY	74
	12.1	Operating the fieldbus gateway	74
	12.2	Selecting the protocol.....	74
	12.3	Enter PROFIBUS address or CC-Link address	75
	12.4	Converting compatibility mode	75
	12.5	Valve configuration.....	75
	12.6	Configure pressure sensor(s)	75
	12.7	Display: contrast, brightness, installation position, language	76
	12.8	Configuration provider.....	76
	12.9	Error diagnostics.....	76
	12.10	Restarting the valve island	76
	12.11	Factory reset	76
	12.12	Reset the switching cycle counters	77
	12.13	Replacing devices (config clients)	77
13		MENU STRUCTURE FIELDBUS GATEWAY.....	78
14		FIELDBUS GATEWAY DISPLAY ELEMENTS	80
	14.1	LEDs for indicating the network connection to Industrial Ethernet.....	80
	14.2	LED for displaying the device status	81
	14.3	Displays	82
15		BÜRKERT COMMUNICATOR BASICS	84
	15.1	User levels.....	85
	15.2	Connecting the device to the Bürkert Communicator	86
16		CONFIGURATION WITH BÜRKERT COMMUNICATOR.....	87
	16.1	Base valve island settings	87
	16.2	Base Industrial Communicator settings.....	87
	16.3	Base settings CANopen/büS.....	89
	16.4	Active pressure sensor	89
	16.5	Disable or enable module supply monitoring	89
	16.6	Change “error” report status	89
	16.7	Reset device to factory settings.....	89
	16.8	Restart device	89
	16.9	Switch time monitoring of actuators	90
	16.10	Disabling access to web server	90
	16.11	Using Extension Modules (EM)	90
17		BÜRKERT COMMUNICATOR MENU STRUCTURE	93
18		START-UP	98
	18.1	Safety instructions	98

18.2	Commissioning via manual override	98
18.3	Identification of the valve positions	99
19	DISPLAY ELECTRONIC MODULE	100
20	COMBINE VALVE ISLAND WITH EXTERNAL DI MODULES.....	103
20.1	Assign position feedback sensor source in the automation software	103
20.2	Assign position feedback sensor source in Bürkert Communicator.....	103
20.3	Network configuration in the Bürkert Communicator	104
20.4	Show errors from bÜS partners on the display.....	108
20.5	Configure external DI modules using a wizard	109
21	SWITCH TIME MONITORING FUNCTION	110
21.1	What exactly is being measured?	110
21.2	Settings for the actuator switching time.....	110
21.3	Start switching time measurement	111
21.4	Error messages for the function of the switching time monitoring	112
22	MICRO SD CARD	113
22.1	Display of memory operation on the fieldbusgateway.....	114
23	BACKUP BATTERY.....	115
24	REPLACING SPARE PARTS.....	116
24.1	Connection module with compressed air supply	116
24.2	Connection module with pressure sensor	118
24.3	Electronic module	120
24.4	Pneumatic valves.....	121
25	REPLACE THE ME43 FIELDBUS GATEWAY	125
26	BASIC VARIANT: RETROFITTING ELECTRONIC MODULE	126
26.1	Mounting an electronic module on the valve island.....	126
26.2	Configuring the electronic module.....	126
27	MAINTENANCE, TROUBLESHOOTING.....	128
27.1	Safety instructions	128
27.2	Replace filter for auxiliary pilot air.....	128
27.3	Troubleshooting	129
27.4	Error messages on the LC display of the electronic modules	130
27.5	Description of the error code	131
28	DISASSEMBLY	135
28.1	Safety instructions	135
29	ACCESSORIES	136
30	PACKAGING AND TRANSPORT	139
31	STORAGE	139
32	ENVIRONMENTALLY FRIENDLY DISPOSAL	139

1 OPERATING INSTRUCTIONS

The operating instructions describe the entire life cycle of the device.

→ Keep these instructions ready to hand at the operation site.

Important safety information!

- ▶ Carefully read these instructions.
- ▶ Observe in particular the safety instructions, intended use and operating conditions.
- ▶ Persons who work on the device must read and understand these instructions.

1.1 Symbols



DANGER

Warns of an immediate danger.

- ▶ Failure to observe will result in death or serious injuries.



WARNING

Warns of a potentially hazardous situation.

- ▶ Failure to observe these instructions may result in serious injuries or death.



CAUTION

Warns of a potential danger.

- ▶ Failure to observe may result in moderate or minor injuries.

CAUTION

Warns of damage.

- ▶ Failure to observe may result in damage to the device or the system.



Indicates important additional information, tips and recommendations.



Refers to information in these operating instructions or in other documentation.

- ▶ Designates instructions to avoid danger.
- Designates a procedure which you must carry out.
- ✓ Designates a result.

MENU Symbol for software interface texts.

1.2 Definition of terms

Term	In these instructions stands for
Actuator, process valve	Pneumatic consumer controlled by the valve island
büS	Bürkert system bus; a communication bus developed by Bürkert, based on the CANopen protocol
EVS	External valve voltage shut-off Valves can be de-energised irrespective of the control signals from the bus master. This safety shutdown can be applied to individual valves, valve units or the entire valve block.
Device, valve island	Valve island AirLINE Type 8652
SIA variant	Variant for safety-related shut-off (see “EVS”)
Pneumatic valve, pilot valve	Pneumatic slide valve that can be integrated into the valve block



Information on cabling büS networks can be found in the " *Cabling Guide for büS / EDIP* ".
You can find the " *Cabling Guide for büS / EDIP* " in the "Operating Instructions" area for type 8652 on the Bürkert homepage country.burkert.com.

2 INTENDED USE

The AirLINE type 8652 valve island is designed to control and record the switching states of pneumatically operated process valves.

- ▶ Use the device only as intended. Non-intended use of the device may be dangerous to people, nearby equipment and the environment.
- ▶ In the potentially explosive atmosphere, only use devices that are approved for this purpose. These devices are identified by a separate “Ex” type label. When used in potentially explosive atmospheres, always observe the details on the separate Ex type label and the supplementary Ex instructions included in the scope of delivery.
- ▶ Prerequisites for safe and trouble-free operation are correct transportation, correct storage, installation, start-up, operation and maintenance.
- ▶ To use the device, observe the permitted data, operating conditions and application conditions. These specifications can be found in the contract documents, the operating instructions and on the type label.
- ▶ Use the device only in conjunction with third-party devices and components recommended or approved by Bürkert.
- ▶ In the outdoor area, make sure that the device is installed in a control cabinet with at least a degree of protection IP 65.
- ▶ In the interior, ensure that the device is installed in a control cabinet with at least a degree of protection IP 20.
- ▶ Do not place the device under mechanical stress, e.g. by placing objects on it or standing on it.
- ▶ Use the device only when it is in perfect condition.



The valve island is intended exclusively for use in the industrial sector.

The valve island is only permitted in applications where there is a danger to life and limb if the SIA and EVS functions provided for this purpose are used with appropriate, approved equipment (safety relays, etc.).

3 BASIC SAFETY INSTRUCTIONS

These safety instructions do not take into account any unforeseen circumstances or events that occur during installation, operation and maintenance. The operator is responsible for observing the location-specific safety regulations, also with reference to personnel.



Risk of injury from high pressure and uncontrolled movement of the actuators.

- ▶ Secure the actuators against shifting before working on the device or plant.
- ▶ Switch off the pressure before working on the device or plant. Vent or empty the lines.

Risk of injury from electric shock.

- ▶ Switch off the power supply before working on the device or system. Secure it against reactivation.
- ▶ Observe any applicable accident prevention and safety regulations for electrical devices.

Risk of burns from hot device parts.

- ▶ Keep the device away from highly flammable substances and media.

Risk of injury due to improper installation, maintenance or operation.

- ▶ Only trained technicians may perform installation and maintenance work.
- ▶ Only trained personnel may operate the device.
- ▶ Perform installation work and maintenance work using suitable tools only.

Risk of injury due to unintentional activation of the device and system and uncontrolled restart.

- ▶ Secure the device and system against unintentional activation.
- ▶ Ensure that the system starts up in a controlled manner only.

Risk of injury due to heavy device.

During transportation or installation work, a heavy device may fall down and cause injuries.

- ▶ Heavy equipment must only be transported, assembled and disassembled with the help of a second person.
- ▶ Use suitable tools.

General hazardous situations.

To prevent injuries, observe the following:

- ▶ Install the device according to the regulations applicable in the respective country.
- ▶ Do not feed any aggressive or combustible media into the media connections of the device.
- ▶ Do not feed any liquids into the device's media connections.
- ▶ Following interruption of the process, ensure that the process is restarted in a controlled manner. Observe the sequence:
 1. Apply electrical supply.
 2. Apply pneumatic supply (in case of external pressure supply, first the external auxiliary pilot air [X / 12/14], then the medium pressure [P / 1]).
- ▶ Do not modify the device.
- ▶ Do not mechanically load the device.
- ▶ Observe the general rules of technical equipment.

CAUTION

Electrostatically sensitive components and assemblies.

The device contains electronic components that are susceptible to the effects of electrostatic discharging (ESD). Components that come into contact with electrostatically charged persons or objects are at risk. In the worst case scenario, these components will be destroyed immediately or fail after start-up.

- ▶ Meet the requirements specified by EN 61340-5-1 to minimise or avoid the possibility of damage caused by a sudden electrostatic discharge.
- ▶ Do not touch electronic components when the supply voltage is connected.

4 GENERAL NOTES

4.1 Contact address

Germany

Bürkert Fluid Control Systems
Sales Centre
Christian-Bürkert-Straße 13–17
D-74653 Ingelfingen
Tel. +49 (0) 7940 - 10 91 111
Fax +49 (0) 7940 - 10 91 448
Email: info@burkert.com

International

The contact addresses can be found on the back pages of the printed Quickstart.

They are also available online at: country.burkert.com

4.2 Warranty

A precondition for the warranty is that the device is used as intended in consideration of the specified operating conditions.

4.3 Information on the Internet

Operating instructions and data sheets for the Bürkert products can be found on the Internet at:

country.burkert.com

5 PRODUCT DESCRIPTION

Thanks to its compact and modular structure with regard to pneumatic and electrical interfaces, the AirLINE type 8652 valve island is suitable for solving diverse and complex control tasks.

The structure of the valve island is optimised for use in control cabinets. The AirLINE Quick adapter plate is already part of the valve island in the basic configuration (Basic variant). With AirLINE Quick, the valve island can be placed on an opening in the control cabinet floor or the control cabinet wall. Alternatively, it can also be installed on the rear wall of the control cabinet using a standard rail.

In the maximum expansion stage, the valve island enables the use of up to 48 valve functions. A clear operating concept and a clear display concept help with installation and maintenance work. The supply manifold is made of aluminium and provides the necessary stability. Both the fluidic elements such as pneumatic slide valves and the electronic modules are attached to it.

Electrical connection occurs via the ME43 fieldbus gateway, thereby allowing the use of a wide range of fieldbus protocols.

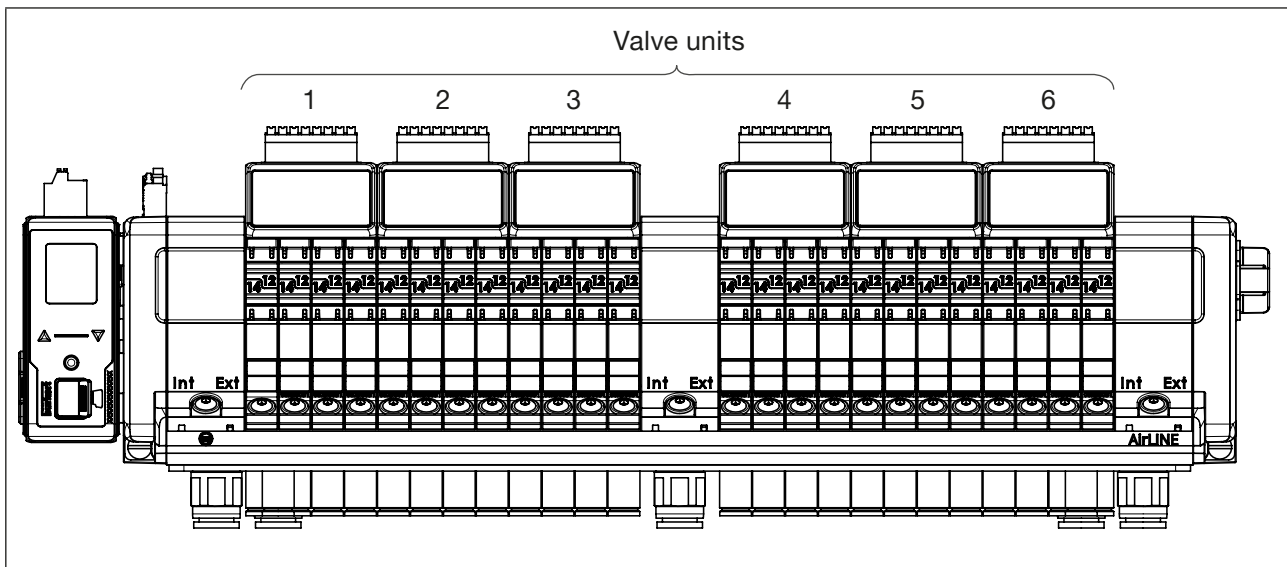

Figure 1: Maximum extension of valve island Type 8652: 6 valve units with a maximum of 8 valve functions per unit

Basic variant

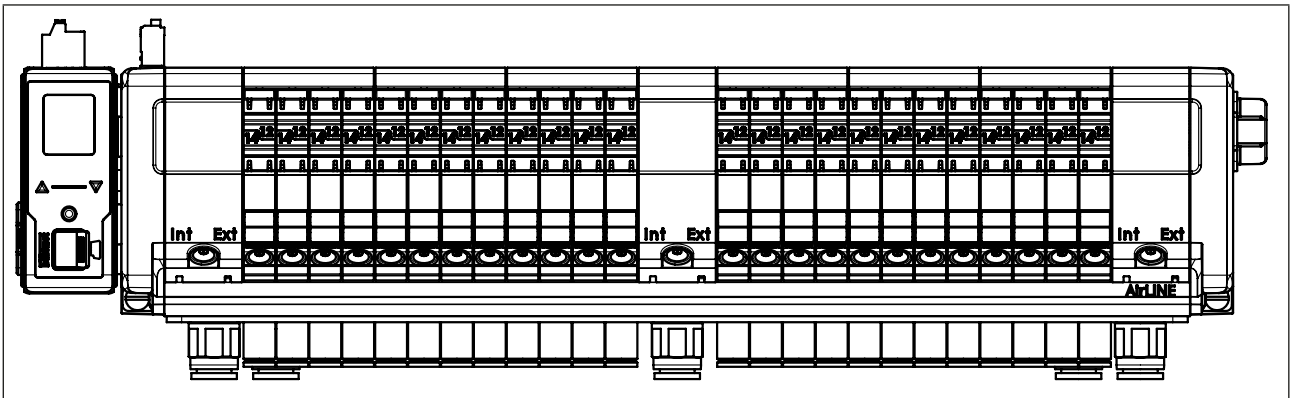

Figure 2: Example of a valve island type 8652 Basic variant

The Basic variant is the basic version of the modular valve island. This variant is designed for standard control and automation technology tasks. The Basic variant has no electronic modules and no digital inputs.

5.1 Product structure

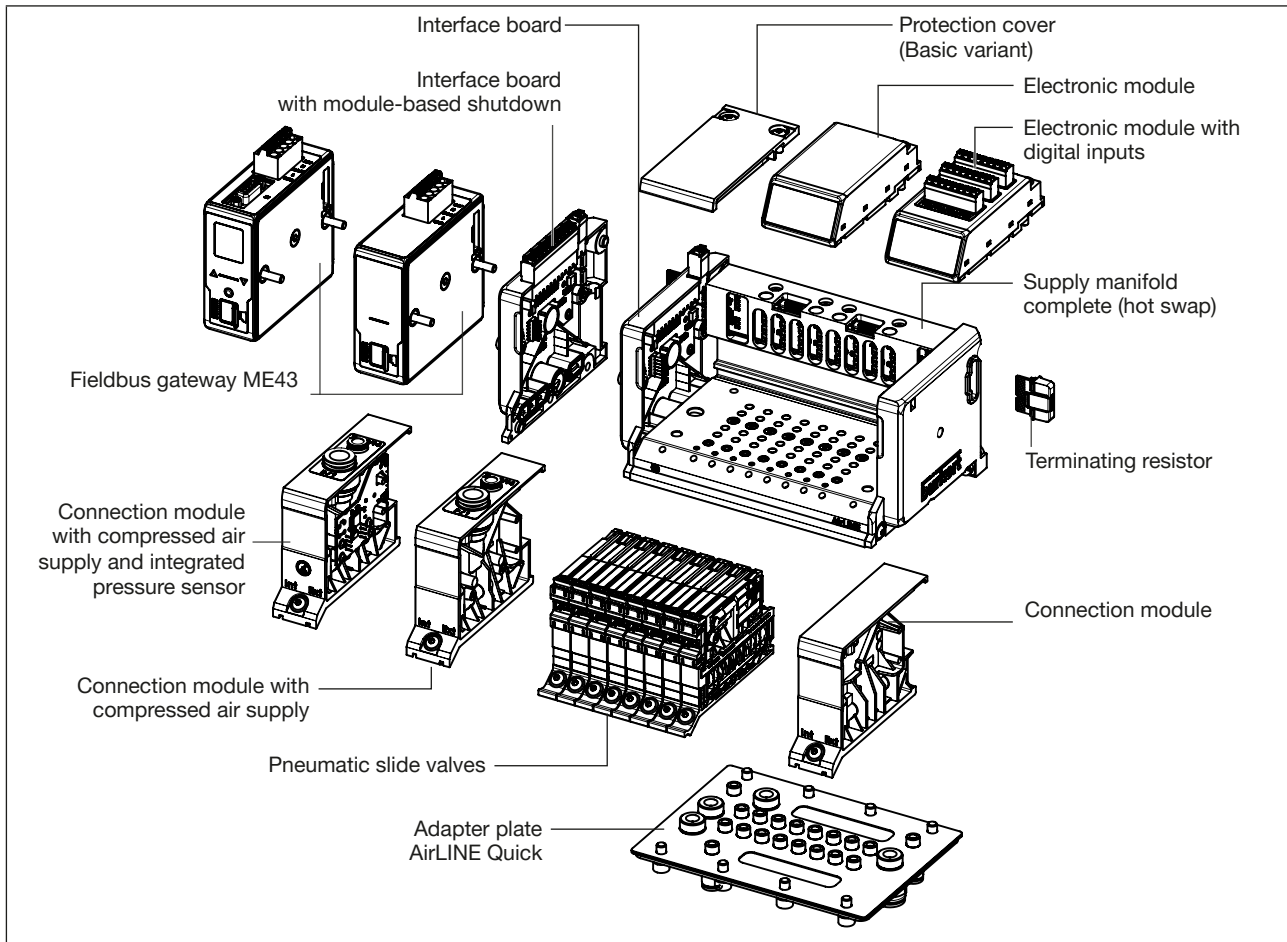

Figure 3: Structure of the valve island type 8652

5.1.1 Fieldbus gateway ME43

Electrical connection occurs via ME43 fieldbus gateway, thereby allowing the use of a wide range of fieldbus protocols. The gateway serves as a fieldbus converter between bus / CANopen and Industrial Ethernet, PROFIBUS DPV1 or CC-Link.

5.1.2 Interface board

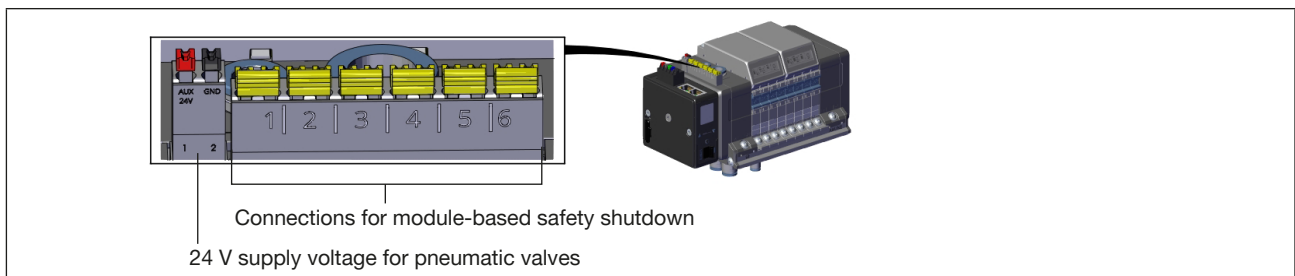

Figure 4: Connections for EVS on the interface board

The interface board has a 2-pole spring-loaded terminal to which the supply voltage for the pneumatic slide valves is connected. This allows the voltage for all pneumatic slide valves of the valve island to be shut down irrespective of the communication to the superordinate controller (PLC). If the voltage is shut down or interrupted, the message “EVS active” appears on all valve island displays.

Interface board with module-based shutdown

The 12-pole spring-loaded terminal is bridged upon delivery. If the bridge is removed, module-based safety shutdown can be performed by means of a connection to a safety relay. All 4 valve slots of a valve unit (see [“Figure 1” on page 12](#)) can therefore be shut down without impacting on further functions of the valve island. If the voltage is shut down or interrupted, the message “EVS active” appears on the display of the respective valve unit.

5.1.3 Connection module

The connection module is used to internally distribute the pilot pressure to the pilot valves. The position of a seal in the connection module can be used to switch to internal or external pilot pressure supply.

Connection module with compressed air supply

Connection modules with a compressed air supply enable the additional compressed air supply of medium pressure and pilot pressure.

Connection module with compressed air supply and integrated pressure sensor

This variant of the connection module is equipped with an integrated pressure sensor. The pressure sensor monitors the medium pressure of the unit and reports the current pressure to the controller. The current medium pressure can be indicated on the valve unit displays.

Minimum values and maximum values for the issuance of warning and error alerts can be specified with the web server (for PROFINET, EtherNet/IP or Modbus TCP) or the software Bürkert Communicator.

5.1.4 Protection cover

In the Basic variant, the protective cover replaces the electronic modules. Protective covers are without display and without digital inputs. They protect the electrical contacts of the backplane from dirt and damage.

5.1.5 Electronic module

The electronics module shows the status of the valves on an LC display.

Electronic module with digital inputs

The digital inputs are used to supply electrical power to the position feedback sensors. The position feedback sensors can be used to show error messages, maintenance intervals or other information on the device status on the LC display of the electronics module.

Standard position feedback sensors (3-wire sensors and 2-wire sensors as well as mechanical limit switches) can be connected to the digital inputs.

Depending on the position feedback sensor used, the following data can be output:

Possible data	3-wire sensors	2-wire sensors	Mech. Limit switches
Position feedback sensor activated	X	X	X
Position feedback sensor not activated	X	X	X
Short circuit	X	–	–
Wire break	–	X	–

Examples of usable position feedback sensors

3-wire sensors:

Bürkert type 8697 (3-wire)

2-wire sensors:

Bürkert type 8697 (2-wire)

Mechanical limit switch:

Bürkert type 8697 (micro switch)

5.1.6 Pneumatic slide valves type 6534

The functioning of the pneumatic slide valves is based on a soft-sealing slide principle. The individual technical values and the various circuit functions of the pneumatic slide valves are described on the data sheet for the valve island type 8652 (see country.burkert.com).

Pneumatic slide valves type 6534 are equipped with manual override. The manual override works without voltage being applied to the valve island and allows manual valve switching (see chapter "18.2").

The standard manual override is spring return and latching. By using the additional element "Manual override locking", the function of the manual override is restricted (purely tentative or blocked).

SIA variant (for safety-related shutdown)

Valves Type 6534 "SIA variant" are equipped with additional connection terminals. The circuit of a valve can therefore be interrupted by an external switch. Manual override is not required for these valve variants.

5.1.7 Supply manifold

The supply manifold is used for the pneumatic supply of the individual valves. The supply manifold is available with and without check valves. By using P shutoff (hot swap), individual valves can be exchanged during operation. The check valves in the ventilation ducts prevent the actuators from being switched unintentionally (e.g. due to uncontrolled pressure peaks).

The supply manifold is designed so that the valve island can be used on the standard rail or directly on the control cabinet floor or the control cabinet wall as AirLINE Quick.

5.1.8 Adapter plate AirLINE Quick

The adapter plate AirLINE Quick in stainless steel enables, for example, the use of the valve island in hygienic applications without great installation effort. The adapter plate allows simple and safe installation in the control cabinet floor or the control cabinet wall.

When the valve island is installed correctly in the control cabinet base or control cabinet wall as specified in chapter "7.1" on page 28, degree of protection IP65 is achieved at the interface between adapter plate AirLINE Quick and the control cabinet.

5.1.9 Terminating resistor

When delivered, each valve island type 8652 contains 1 terminating resistor (see "Figure 3"). If several valve islands are connected in a line, only the last device within this line may contain a terminating resistor. The terminating resistors of the other devices must be removed by pulling them off to the right of the device.

5.2 External safety-related shutdown of valves

There are several ways to de-energise valves irrespective of the control signals from the bus master.

- **Single valves only**

Pneumatic slide valves Type 6534 “SIA variant” are equipped with additional connection terminals. The circuit of a valve can therefore be interrupted by an external switch. An external shutdown of the valves is not shown on the associated display. Shutdown takes place via the connection terminal of the valve regardless of the state of the valve island.

- **All the valves of a valve unit (module-based safety shutdown):**

If the interface board is additionally equipped with a 12-pole spring-loaded terminal, module-based safety shutdown is possible.

The spring-loaded terminal is bridged upon delivery. If the bridge is removed, all 4 valve slots of a valve unit can be shut down by means of a connection to a safety relay without impacting on further functions of the valve island.

If a valve unit is shut down, the message “EVS active” appears on the display of the valve unit.

- **All valves of the valve block:**

By shutting down the supply voltage of the valve block (via the 2-pole spring-loaded terminal), all valves are immediately de-energised (the energy contained in the energy packs of the valve block is negligible). The message “EVS active” is displayed on all displays of the valve island.

The latter two options have the advantage that the logic, display and diagnostics continue unaffected, thus remaining available.

6 TECHNICAL DATA

6.1 Standards and directives

The device complies with the relevant EU harmonisation legislation. In addition, the device also complies with the requirements of the laws of the United Kingdom.

The harmonised standards that have been applied for the conformity assessment procedure are listed in the current version of the EU Declaration of Conformity/UK Declaration of Conformity.

6.2 Operating conditions

Ambient temperature	-10...+55 °C
Storage temperature	-10...+60 °C
Altitude	For UL approved versions limited to max. 2000 m above sea level
Degree of protection	IP20

6.3 Pneumatic data

Control medium	Compressed air quality ISO 8573-1: 2010, class 7.4.4
Pressure range	See chapter “6.6”
Connections:	
Pressure port (P/1) Exhaust ports (S / 3, R / 5)	Plug-in coupling Ø 10 mm or Ø D3/8
Pressure port auxiliary pilot air (X / 12/14) ¹ Exhaust port auxiliary pilot air (R' / 82/84) ¹	Plug-in coupling Ø 6 mm or Ø D1/4
Working ports	

¹⁾ With the Basic variant, the equipment of the connections for auxiliary pilot air (X / 12/14 and R' / 82/84) can vary.

6.4 General electrical data

CAUTION

► Use safety extra-low voltage according to protection class III EN 61140, VDE 0140.

Nominal operating mode	Continuous operation (100% duty cycle)																
Operating voltage	24 V _{DC} ± 10%, residual ripple with fieldbus interface max. 1 V _{SS} ²																
Current consumption	<p>The current consumption depends on the configuration of the valve island.</p> <p>The total current for the fieldbus interface is calculated according to the formula:</p> $I_{tot} = I_{basic} + (n \times I_{valve}) + (m \times I_{feedback}) + (k \times I_{electr. mod.})$ <p>I_{tot} : Total current</p> <p>I_{basic} : Basic current depending on the fieldbus system</p> <table> <tr><td>PROFINET/PROFINET S2:</td><td>135 mA</td></tr> <tr><td>EtherNet/IP:</td><td>135 mA</td></tr> <tr><td>Modbus TCP:</td><td>135 mA</td></tr> <tr><td>EtherCAT:</td><td>135 mA</td></tr> <tr><td>CC-Link IE Field Basic:</td><td>135 mA</td></tr> <tr><td>PROFIBUS DPV1:</td><td>120 mA</td></tr> <tr><td>BüS /CANopen:</td><td>70 mA</td></tr> <tr><td>CC-Link:</td><td>120 mA</td></tr> </table> <p>n: Number of valves (max. 48 when using 24 double valves 2x3 / 2-way)</p> <p>I_{Valve} : Nominal current of the valve (30 mA)</p> <p>m: Number of position feedback sensors (max. 48)³</p> <p>$I_{feedback}$: Current consumption of position feedback sensor (max. 30 mA)</p> <p>k: Number of electronic modules (Max. 6)³</p> <p>$I_{electr. mod.}$: Current consumption of electronic modules ((21 mA)</p>	PROFINET/PROFINET S2:	135 mA	EtherNet/IP:	135 mA	Modbus TCP:	135 mA	EtherCAT:	135 mA	CC-Link IE Field Basic:	135 mA	PROFIBUS DPV1:	120 mA	BüS /CANopen:	70 mA	CC-Link:	120 mA
PROFINET/PROFINET S2:	135 mA																
EtherNet/IP:	135 mA																
Modbus TCP:	135 mA																
EtherCAT:	135 mA																
CC-Link IE Field Basic:	135 mA																
PROFIBUS DPV1:	120 mA																
BüS /CANopen:	70 mA																
CC-Link:	120 mA																

MAN 1000338074 EN Version: AF Status: RL (released | freigegeben) printed: 23.05.2024

2) UL approved versions must be supplied in one of the following ways:
 a. "Limited Energy Circuit" (LEC), according to UL / IEC61010-1
 b. "Limited Power Source" (LPS), according to UL / IEC60950
 c. SELV / PELV with UL-approved overcurrent protection, designed according to UL / IEC61010-1, Table 18
 d. NEC Class 2 power supply unit

3) Basic variant: Electronic modules and digital inputs are not included in the scope of delivery. When calculating the total current, enter the value "0" for the variables "m" and "k"

6.5 Electrical data of electronic module with digital inputs

Module properties	
Diagnosics	Wire break detection for 2-wire sensors Short circuit detection for 3-wire sensors
Safety	Protection against overvoltage
Electrical data	
Electrical connection (position feedback sensor)	2-wire sensors 3-wire sensors Mechanical limit switches
Input type	Type 1 and type 3 according to IEC 61132-2
Conductor cross-section	$\leq 1.5 \text{ mm}^2$
Max. Cable length	<30 m
Sensor supply (position feedback sensor)	
Current consumption	8 x max. 30 mA
Voltage	24 V \pm 10 %
Input current for $V_{ON} = \text{type } 24 \text{ V DC}$	Type 5.8 mA
Input impedance	> 3 k Ω
Switching threshold	$V_{OFF} = 0...5 \text{ V}$ $V_{ON} = 10...30 \text{ V}$
Electrical isolation	No

6.6 Pneumatic slide valve type 6534

Circuit function (CF)	2 x CFC ⁴ NC (normally closed) 2 x 3/2-way 2 x CFD NO (normally open) 2 x 3/2-way	CF H ⁴ 5/2-way monostable CFZ 5/2-way bistable	CFL ⁴ 5/3-way blocked CFM 5/3-way pressurised CFN 5/3-way vented
Flow rate Q_{Nn}	up to 310 l _N / min (for exact flow values for the different circuit functions, see data sheet)		
Medium pressure ⁵	0 ... 10 bar		
Control pressure ⁶	3 ... 10 bar		
Electr. Power before / after power reduction	2 x 0.7 W / 2 x 0.175 W	0.7 W/0.175 W	0.7 W/0.175 W
Current before / after power reduction	2 x 29 mA / 2 x ≤ 10 mA	29 mA / ≤ 10 mA	

- 4) Also available as the SIA variant (see chapter "8.6" on page 40)
- 5) For pressure values from vacuum to 3 bar, observe the pilot pressure diagram and set the supply of auxiliary pilot air to "external" (take chapter "9.1.1 External and internal auxiliary pilot air" on page 45 into consideration here).
- 6) For the "External auxiliary pilot air" variant, select the pilot pressure according to the pilot pressure diagram.

6.6.1 Control pressure diagram

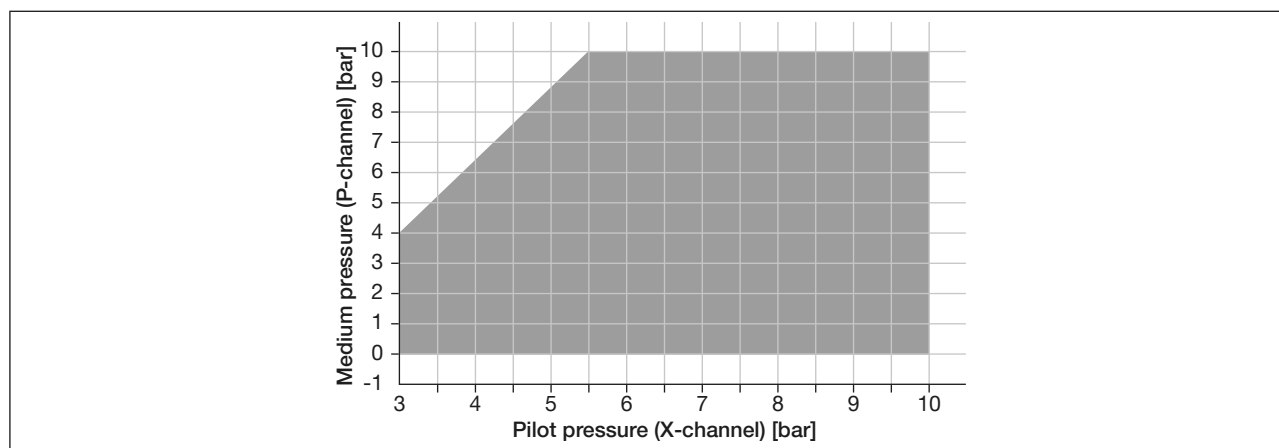

Figure 5: Control pressure diagram for pneumatic slide valve type 6534

6.7 Circuit function (CF)

Circuit function (CF)	Symbol according to ISO 1219-1	Description
2 x CFC ⁷		Outlet 2 and outlet 4 vented when idle.
2 x CFD		Outlet 2 and outlet 4 aerated when idle.
CF H ⁷		Pressure port 1 connected to outlet 2 when idle, outlet 4 vented.
CFZ		5/2-way valve bistable; Depending on the switch position, either output 2 is vented and output 4 is vented or output 2 is vented and output 4 is aerated.
CFZ *		For CFZ *: With regard to valves with circuit function Z*, the valve island software ensures that the newly installed valve adopts the switch setting of the original valve in the event that a valve is replaced (hot swap). For valves with circuit function Z*, manual override is disabled after the first electrical activation.
CFL ⁷		All connections blocked in the idle position.
CFM		In the idle position, output 2 and output 4 are pressurised.
CFN		Outlet 2 and outlet 4 vented when idle.

⁷⁾ Type 6534 variant SIA (variant for safety-related shutdown)
The type 6534 valves can optionally be equipped with a second electrical connection (connection terminal). Safety-related shut-off is therefore possible for each channel individually. The valve variants are without manual override. See also chapter "8.6" on page 40

6.8 Standard type label (example)

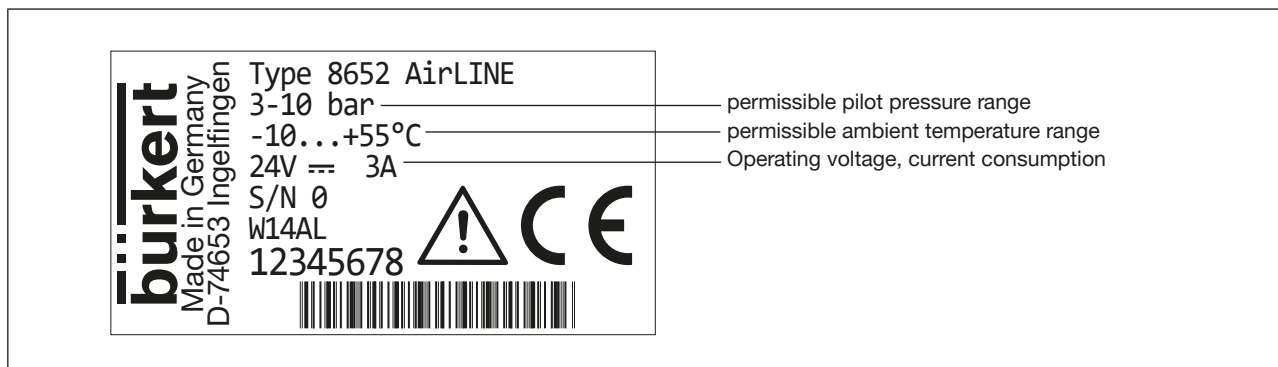

Figure 6: Type label standard valve island type 8652

6.9 Type label UL (example)

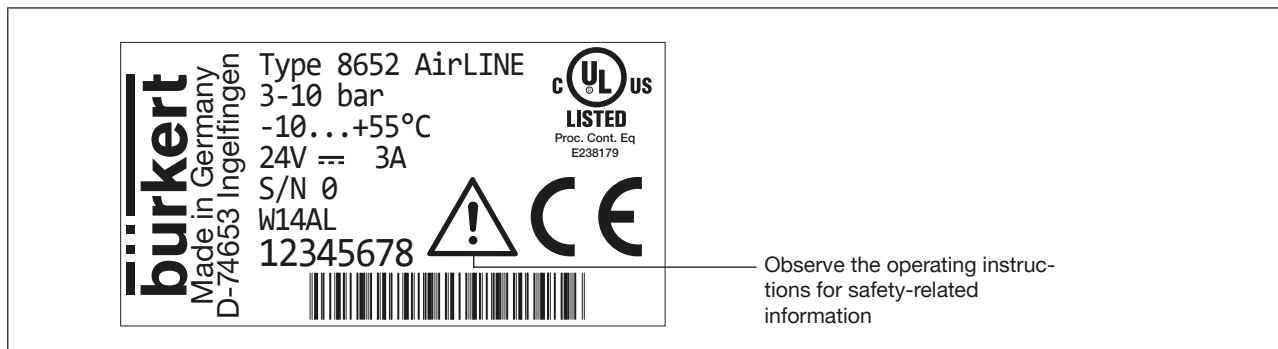

Figure 7: Type label UL valve island type 8652

6.10 Industrial Ethernet specifications

6.10.1 PROFINET/PROFINET S2

Topology recognition	LLDP, SNMP V1, MIB2, Physical Device
Minimum cycle time	10 ms
IRT	not supported
MRP media redundancy	MRP client is supported
Other supported functions	DCP, VLAN Priority Tagging, Shared Device
Transmission speed	100 Mbit/s
Data transport layer	Ethernet II, IEEE 802.3
PROFINET IO specification	V2.42
Application Relations (AR)	<p>PROFINET: The device can simultaneously process up to 2 IO ARs, 1 Supervisor AR, and 1 Supervisor DA AR.</p> <p>PROFINET S2: The device can simultaneously establish one connection to the primary and one connection to the backup.</p>

6.10.2 EtherNet/IP

Pre-defined standard objects	<p>Identity Object (0x01)</p> <p>Message Router Object (0x02)</p> <p>Assembly Object (0x04)</p> <p>Connection Manager (0x06)</p> <p>DLR Object (0x47)</p> <p>QoS Object (0x48)</p> <p>TCP/IP Interface Object (0xF5)</p> <p>Ethernet Link Object (0xF6)</p>
DHCP	supported
BOOTP	supported
Transmission speed	10 and 100 MBit/s
Duplex modes	Half duplex, full duplex, auto-negotiation
MDI modes	MDI, MDI-X, Auto-MDI-X
Data transport layer	Ethernet II, IEEE 802.3
Address Conflict Detection (ACD)	supported
DLR (ring topology)	supported
CIP reset service	Identity Object Reset Service Type 0 and Type 1

6.10.3 Modbus TCP

Modbus function codes	1, 3, 6, 15, 16
Transmission speed	10 and 100 MBit/s
Data transport layer	Ethernet II, IEEE 802.3

6.10.4 EtherCAT



Ethernet interface X1, X2	X1: EtherCAT IN X2: EtherCAT OUT
Acyclic communication (CoE)	SDO
Type	Complex Slave
FMMUs	8
Sync Managers	4
Transmission speed	100 Mbit/s
Data transport layer	Ethernet II, IEEE 802.3

EtherCAT® is a registered trademark and patented technology, licensed by Beckhoff Automation GmbH, Germany

6.10.5 CC-Link IE Field Basic

Number of occupied stations	1...16
Acyclic communication	SLMP Server
Data transport layer	Ethernet II, IEEE 802.3, 100 MBit/s
CC-Link interface	Cyclic data 61450 (UDP) Discovery and SLMP Server 61451 (UDP) SLMP Communication 20000 (UDP)

6.11 Specifications PROFIBUS DPV1

Acyclic communication	DPV1 Class 1 Read/Write DPV1 Class 2 Read / Write / Data Transport
Transmission speed	fixed values from 9.6 kbit / s to 12 Mbit / s Autodetect mode is supported

6.12 CC-Link specifications

CC-Link version 2.0	
Number of stations	Up to 4 occupied stations
Extended cycles	1
Input data	32 bytes (RWw)
Output data	32 bytes (RWr)
Transmission speeds	156 kbit / s, 625 kbit / s, 2500 kbit / s, 5 Mbit / s, 10 Mbit / s
CC-Link version 1.1	
Number of stations	Up to 4 occupied stations
Input data	8 bytes (RWw) per occupied station
Output data	8 bytes (RWr) per occupied station
Transmission speeds	156 kbit / s, 625 kbit / s, 2500 kbit / s, 5 Mbit / s, 10 Mbit / s

7 INSTALLATION OF THE VALVE ISLAND IN THE CONTROL CABINET

WARNING

Risk of injury due to improper installation.

- ▶ Only trained technicians may perform installation work.
- ▶ Perform installation work using suitable tools only.

CAUTION

Risk of injury due to heavy device.

During transportation or installation work, a heavy device may fall down and cause injuries.

- ▶ Heavy equipment must only be transported, assembled and disassembled with the help of a second person.
- ▶ Use suitable tools.

 The AirLINE type 8652 valve island is supplied as a fully assembled device. Modifications are only permitted to be carried out by Bürkert.

The valves are excluded from this and may be exchanged by the user for valves of the same variant.

There are 2 options for placing the valve island in the control cabinet:

1. On the control cabinet floor or the control cabinet wall with AirLINE Quick

The AirLINE Quick adapter plate is a standard part of the valve island. The AirLINE Quick adapter plate enables the valve island to be positioned on a cutout on the control cabinet floor or on the control cabinet wall. This means that the pneumatic connection of the valve island can be made outside the control cabinet.

When the valve island is installed correctly in the control cabinet base or control cabinet wall as specified in chapter “7.1” on page 28, degree of protection IP65 is achieved at the interface between adapter plate AirLINE Quick and the control cabinet.

2. On the rear wall of the control cabinet with a standard rail

The valve island is mounted on the rear wall of the control cabinet using a standard rail.

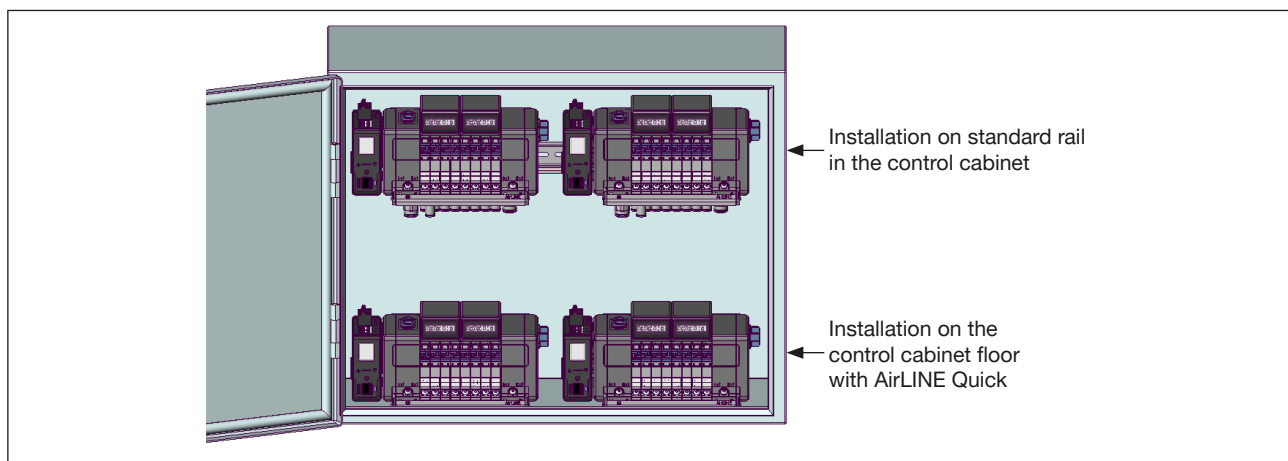

Figure 8: Options for placing the valve island in the control cabinet

7.1 Installation on the control cabinet floor or the control cabinet wall with AirLINE Quick

WARNING

Danger due to electromagnetic disruptions.

If the functional earth (FE) is not connected, then the requirements of the EMC protection are not met and malfunctions may occur on the unit.

- ▶ Connect the control cabinet housing to the functional earth (FE) using a short cable with a large cross-section.
- ▶ Only use shielded cables.

For installation with AirLINE Quick, a cutout must first be provided on the control cabinet floor or the control cabinet wall and holes for the fastening screws. The recess can be done with a laser or a punch (see “7.1.1 Dimensions of the flange pattern AirLINE Quick”).

CAUTION

The recess on the control cabinet must be burr-free so that the seal between the AirLINE Quick and the control cabinet is not damaged.

When measuring the excavation, note:

To be able to use the Hot-Swap function (valve replacement during operation), there must be a minimum distance from the front edge of the control cabinet when installing the valve island in the control cabinet (see “Figure 10”). The valves can only be pulled out of the valve island to the front if the minimum distance is observed.

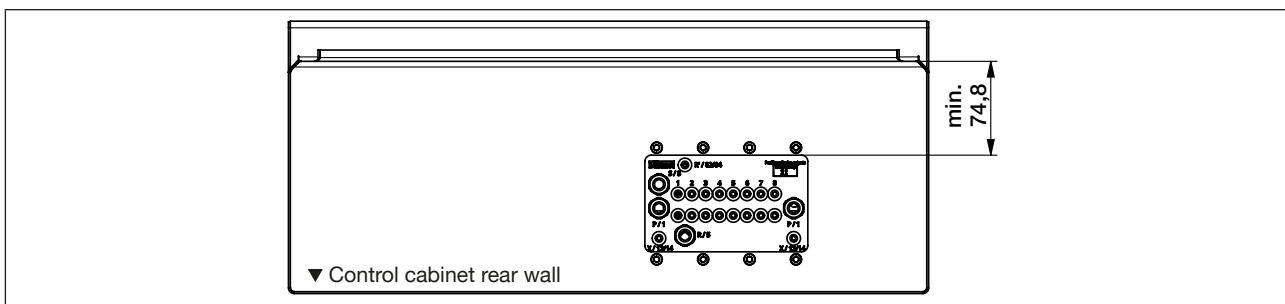

Figure 9: Make the cut-out in the control cabinet floor close to the rear wall of the control cabinet.

The minimum distances to the left, right, front and top depend on the position of the valve island in the control cabinet:

Position in the control cabinet	front	left	right	Top	Bottom
Installation on the control cabinet floor	60.5 mm	30 mm	50 mm	50 mm	–
Installation on the right of the control cabinet wall	60.5 mm	50 mm	–	50 mm	30 mm
Installation on the control cabinet wall on the left	60.5 mm	–	50 mm	30 mm	50 mm

Table 1: The minimum distances refer from the outer edge of the valve island to the inner edge of the control cabinet

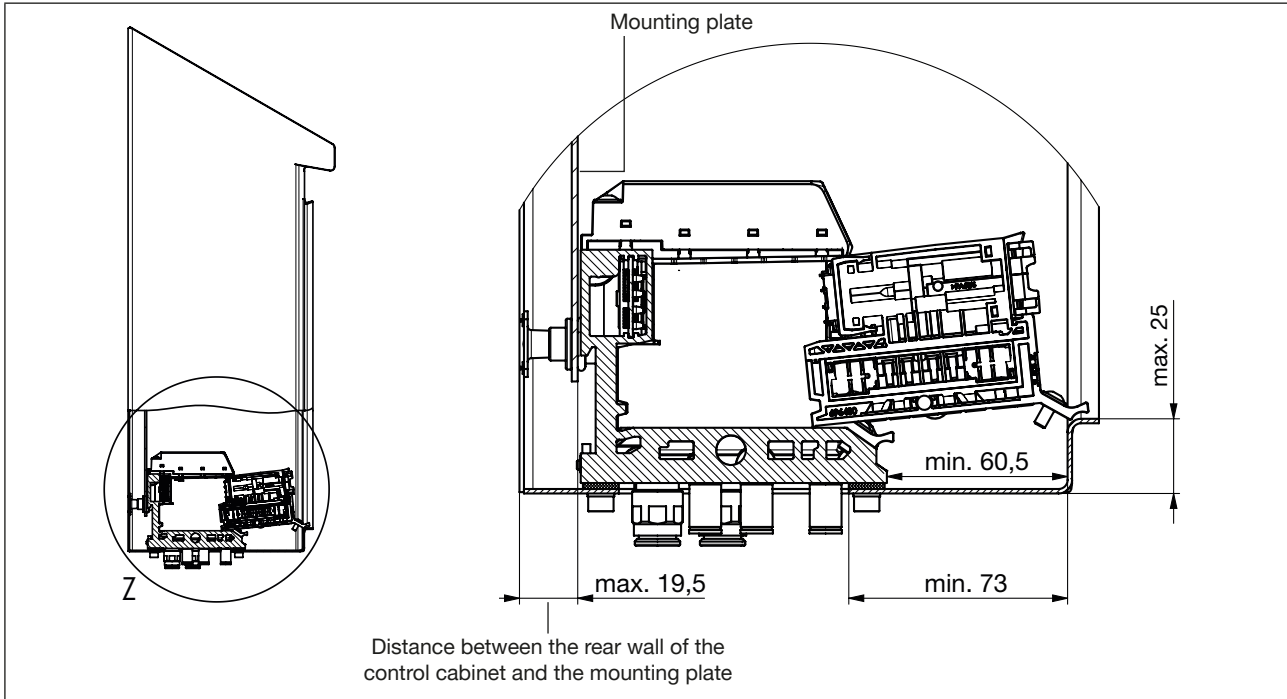

Figure 10: To be able to use the Hot-Swap function, there must be a minimum distance from the front edge of the control cabinet when installing the valve island in the control cabinet.

7.1.1 Dimensions of the flange pattern AirLINE Quick

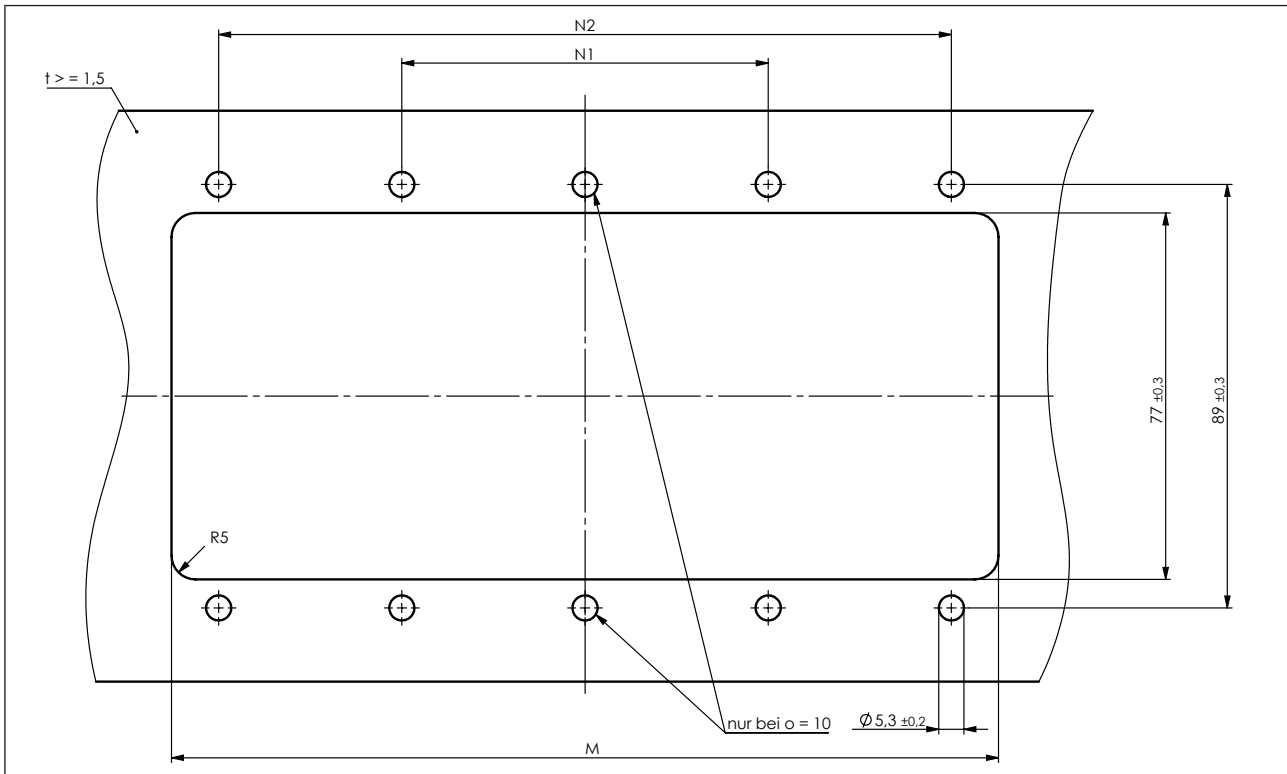

Figure 11: Flange pattern AirLINE Quick - for dimensions, see table 2

Number of valves	M [mm]	N1 [mm]	N2 [mm]	Number of holes
4	85.8 ±0.3	66 ±0.3	–	4
8	129.8 ±0.4	37 ±0.3	111 ±0.4	8
12	173.8 ±0.4	77 ±0.3	154 ±0.4	10
16	244 ±0.4	112 ±0.3	224 ±0.4	10
20	288 ±0.4	134 ±0.3	268 ±0.4	10
24	332.1 ±0.4	156 ±0.3	312 ±0.4	10

Table 2: Dimensions of the flange pattern AirLINE Quick

7.1.2 Install the valve island in the control cabinet

- Check whether the seal between the AirLINE Quick and the control cabinet is free of damage.
- Place the valve island in the control cabinet in the prepared recess.
- Fasten from the outside with M5x10 screws (tightening torque 2.5 Nm).

7.2 Standard rail installation

WARNING

Danger due to electromagnetic disruptions.

If the functional earth (FE) is not connected, then the requirements of the EMC protection are not met and malfunctions may occur on the unit.

- ▶ Connect the standard rail to the functional earth (FE) using a short cable with a large cross-section or a copper tape.
- ▶ Only use shielded cables.

The valve island must be freely accessible from above. Ensure good heat dissipation.

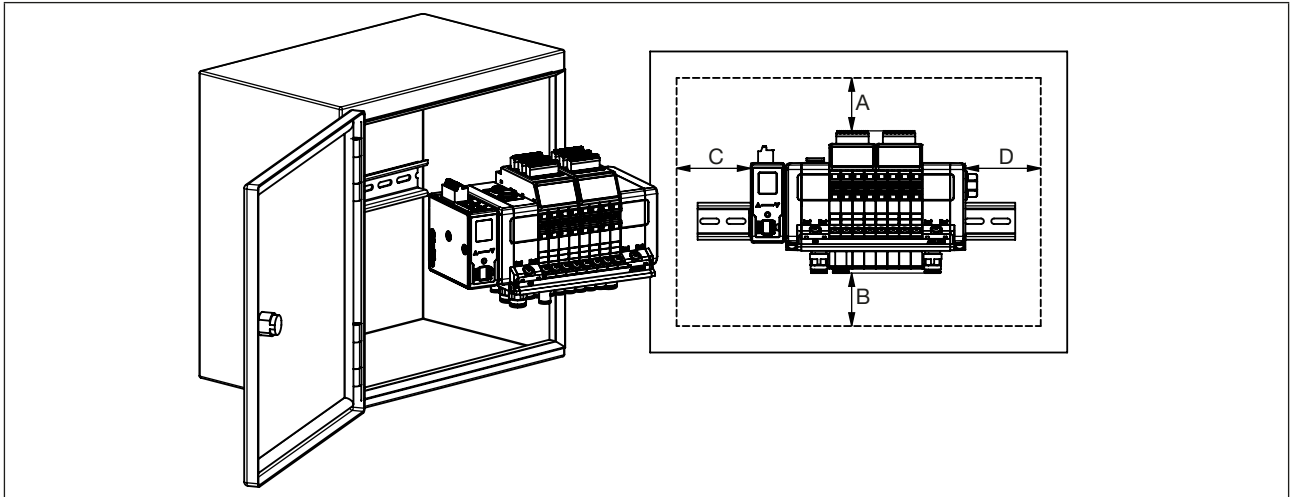

Figure 12: Recommended minimum clearances when installing on a standard rail in the control cabinet

Recommended minimum distances [mm]

	A	B	C	D
Standard	50	30	30	50
Basic variant	80			

- Install the standard rail firmly in the control cabinet.
- Establish a short, wide PE connection between the standard rail and the control cabinet.
- Hook the valve island onto the upper guide of the standard rail.
- Fasten the valve island to the standard rail with the two fastening screws (tightening torque 1.5 Nm).

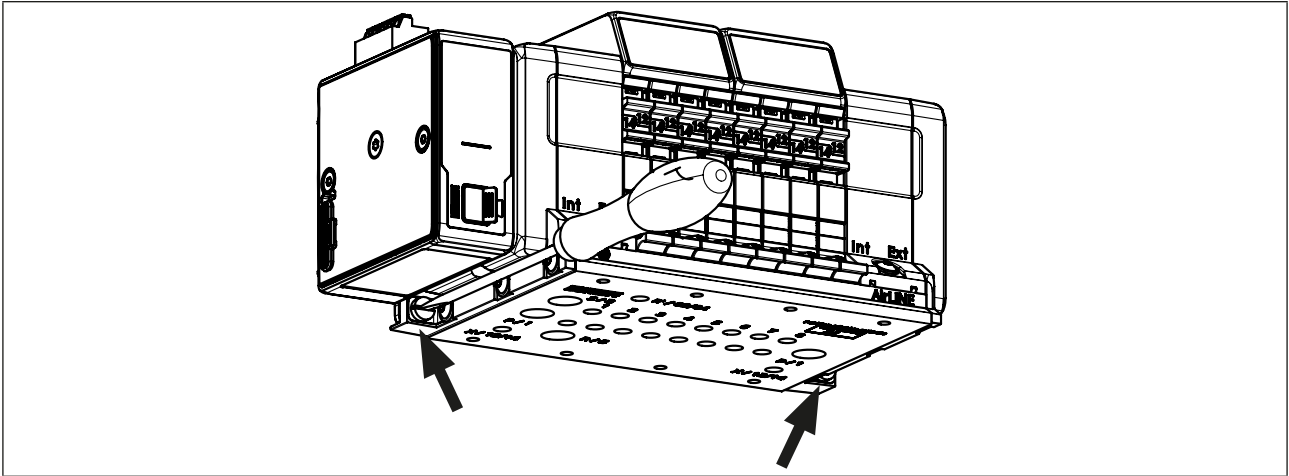

Figure 13: Fastening screws for valve island on standard rail

8 ELECTRICAL CONNECTION

CAUTION

Risk of injury from electric shock.

- ▶ Switch off the power supply before working on the device or system. Secure against reactivation.
- ▶ Observe any applicable accident prevention and safety regulations for electrical devices.

Risk of injury if the electrical connection is incorrect.

- ▶ Only trained specialists are allowed to make the electrical connection.
- ▶ Make the electrical connection only with a suitable tool.

8.1 Cabling of bÜS networks



Information on cabling bÜS networks can be found in the " *Cabling Guide for bÜS / EDIP* ". You will find the " *Cabling Guide for bÜS / EDIP* " in the "Operating Instructions" area for type 8652 on the Bürkert homepage country.burkert.com .

8.2 Fieldbus gateway ME43

8.2.1 Gateway with CANopen / bÜS interface

→ Connect 5-pin spring-loaded terminal according to the assignment.

Possible cable cross-section: $\leq 1.5 \text{ mm}^2$ (see also Chapter "29 Accessories")

Assignment 5-pin spring-loaded terminal		
Plug view	Terminal colour	Description
	Red	Supply voltage 24 V \equiv
	White	CAN_H (bÜS connection)
	Green	Shielding
	Blue	CAN_L (bÜS connection)
	Black	GND

Table 3: Assignment 5-pin spring-loaded terminal

8.2.2 Gateway with Industrial Ethernet interface

The following protocols are supported:

Industrial Ethernet device	PROFINET S2 device
<ul style="list-style-type: none"> • EtherCAT • EtherNet/IP • Modbus TCP • PROFINET • CC-Link IE Field Basic 	<ul style="list-style-type: none"> • PROFINET S2

→ Connect 5-pin spring-loaded terminal according to the assignment.
Possible cable cross-section: $\leq 1.5 \text{ mm}^2$ (see also Chapter “29 Accessories”)

→ Plug the Ethernet cables into the sockets of interfaces X1 and X2.
The interfaces X1 and X2 for RJ45 push-in connectors are equivalent.

Assignment 5-pin spring-loaded terminal		
Plug view	Terminal colour	Description
	Red	Supply voltage 24 V ---
	White	CAN_H (bùS connection) ⁸
	Green	Shielding
	Blue	CAN_L (bùS connection) ⁸
	Black	GND

Table 4: Assignment 5-pin spring-loaded terminal

Assignment interface X1 and X2		Pin	Plug configuration RJ45
	1	TX+	
	2	TX-	
	3	RX+	
	4	Not used	
	5		
	6	RX-	
	7	Not used	
	8		

Figure 14: Allocation of interfaces X1 (EtherCAT IN) and X2 (EtherCAT OUT); Connection to the fieldbus

MAN 1000338074 EN Version: AF Status: RL (released | freigegeben) printed: 23.05.2024

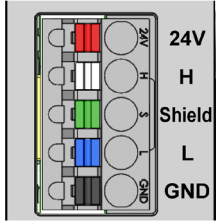
⁸⁾ Only occupied when using several Bürkert devices (EDIP) or in connection with the communicator.

8.2.3 Gateway with PROFIBUS DPV1 interface

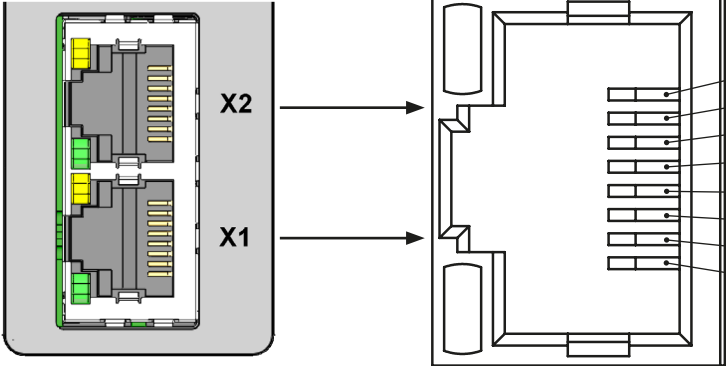
→ Connect 5-pin spring-loaded terminal according to the assignment.

Possible cable cross-section: $\leq 1.5 \text{ mm}^2$ (see also Chapter "29 Accessories")

→ Connection of a 9-pin D-Sub plug to the PROFIBUS DPV1 interface according to the assignment.

Assignment 5-pin spring-loaded terminal		
Plug view	Terminal colour	Description
	Red	Supply voltage 24 V ===
	White	CAN_H (büS connection) ⁹
	Green	Shielding
	Blue	CAN_L (büS connection) ⁹
	Black	GND

Table 5: Assignment 5-pin spring-loaded terminal

Allocation of push-in connector D-Sub, 9-pin				
D-Sub, 9-pin	Pin	Signal	Function	Connection
	1	Not used		
	2	Not used		
	3	RxD/TxD-P	Data line P (B conductor)	Duty
	4	CNTR-P	Repeater directional control	optional
	5	DGND	Weight	optional
	6	VP	+5 V	optional
	7	Not used		
	8	RxD/TxD-N	Data line N (A conductor)	Duty
	9	Not used		

Figure 15: PROFIBUS DPV1, assignment of D-Sub 9-pin push-in connector

MAN 1000338074 EN Version: AF Status: RL (released | freigegeben) printed: 23.05.2024

⁹ Only occupied when using several Bürkert devices (EDIP) or in connection with the communicator.

8.2.4 Gateway with CC-Link interface

- Connect 5-pin spring-loaded terminal according to the assignment.
Possible cable cross-section: $\leq 1.5 \text{ mm}^2$ (see also Chapter "29 Accessories")
- Connection of a D-sub 9-pin plug to the CC-Link - interface according to the assignment.

Assignment 5-pin spring-loaded terminal		
Plug view	Terminal colour	Description
	Red	Supply voltage 24 V $\overline{=}$
	White	CAN_H (bùS connection) ¹⁰
	Green	Shielding
	Blue	CAN_L (bùS connection) ¹⁰
	Black	GND

Table 6: Assignment 5-pin spring-loaded terminal

Allocation of push-in connector D-Sub, 9-pin				
D-Sub, 9-pin	Pin	Signal	Function	Connection
	1	Not used		
	2	Not used		
	3	DA	Data line A	Duty
	4	DG	Data ground	Duty
	5	Not used		
	6	Not used		
	7	Not used		
	8	DB	Data line B	Duty
	9	Not used		

Figure 16: CC-Link, pin assignment D-Sub 9-pin push-in connector

MAN 1000338074 EN Version: AF Status: RL (released | freigegeben) printed: 23.05.2024

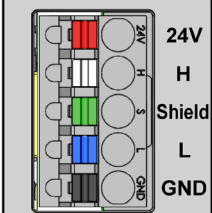
¹⁰⁾ Only occupied when using several Bürkert devices (EDIP) or in connection with the communicator.

8.3 24 V supply voltage for pneumatic valves

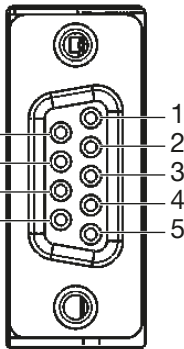
The interface board has a 2-pole spring-loaded terminal to which the supply voltage for the pneumatic valves is connected. This allows the voltage for all pneumatic valves of the valve island to be shut down irrespective of the communication to the superordinate controller (PLC).



	Terminal	Assignment
	1, red	AUX 24 V
	2, black	GND

Figure 17: Assignment of the 2-pole spring-loaded terminal

8.4 Electronic module with digital inputs

→  Switch off the supply voltage.

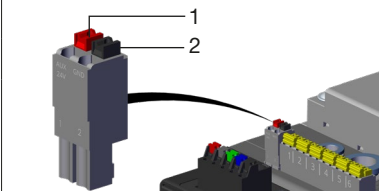
→ Connect the position feedback sensors to the electronics module according to the assignment.
Possible cable cross-section: $\leq 1.5 \text{ mm}^2$ Maximum cable length: $<30 \text{ m}$

The electrical supply to the position feedback sensors (24 V) is provided by the electronic module.

→ Limit the current consumption of position feedback sensors to 30 mA!

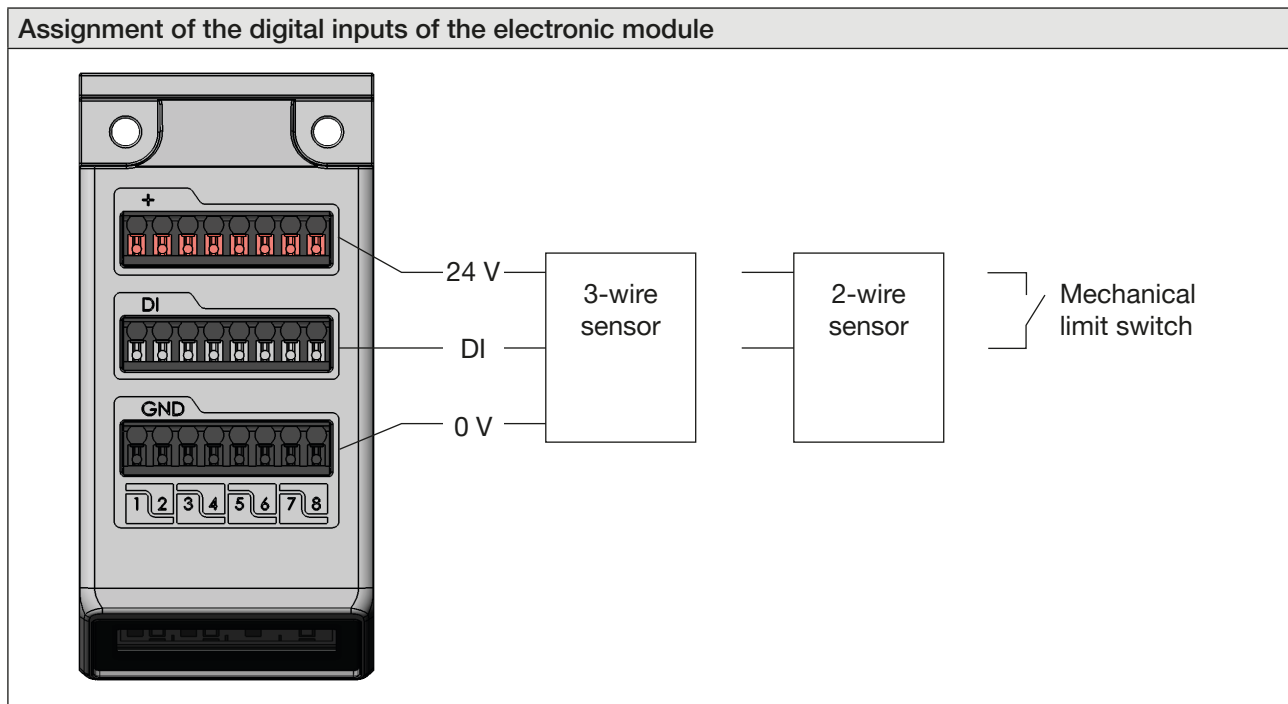

Figure 18: Assignment of the digital inputs of the electronic module

Standard position feedback sensors (3-wire sensors and 2-wire sensors as well as mechanical limit switches) can be used.

Depending on the position feedback sensor used, the following data can be output:

Possible data	3-wire sensors	2-wire sensors	Mech. Limit switches
Position feedback sensor activated	X	X	X
Position feedback sensor not activated	X	X	X
Short circuit	X	–	–
Wire break	–	X	–

8.5 Electrical connection assignment

8.5.1 Upper end position

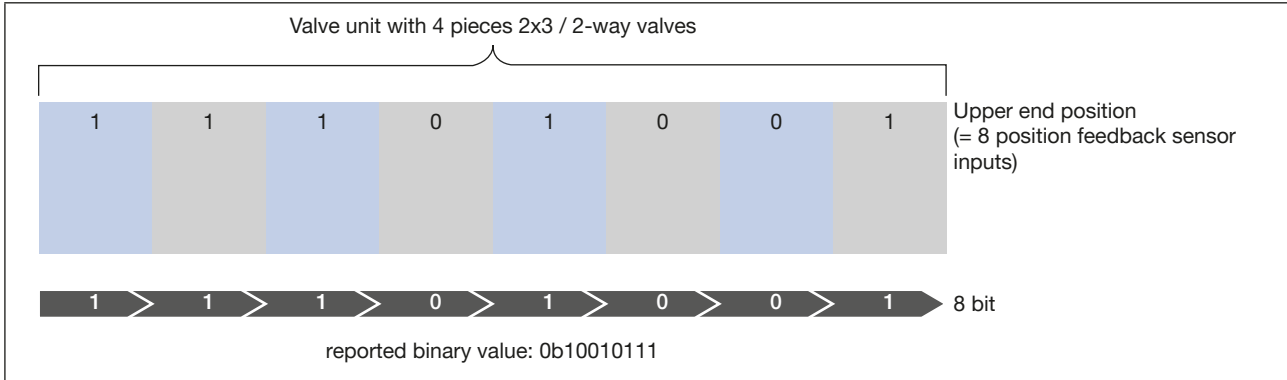

Figure 19: Example of upper end positions for a valve unit with 4 2x3 / 2-way valves

8.5.2 Lower end position

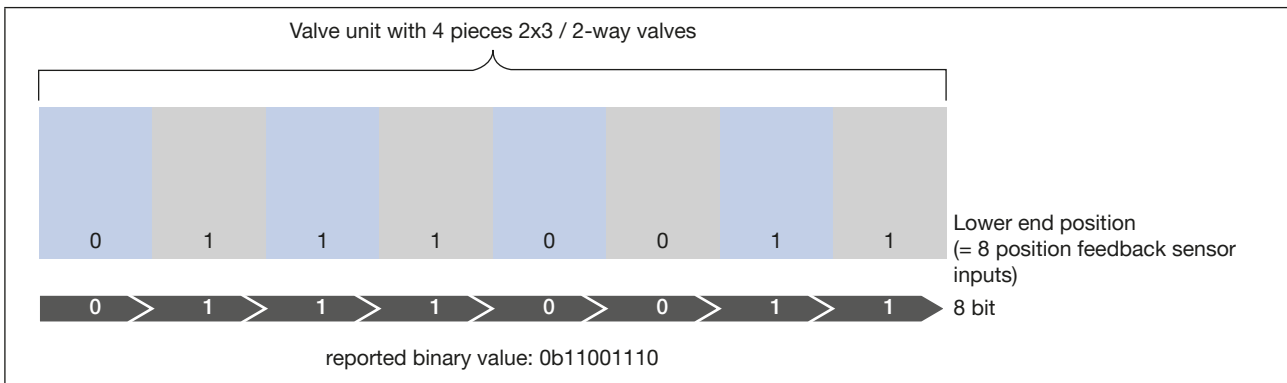

Figure 20: Example of lower end positions for a valve unit with 4 2x3 / 2-way valves

8.5.3 Changing end positions

Changing end positions only affect the 5/2-way valves, since 8 bits are sufficient for the transmission of all values for the entire valve unit. With the changing end position, the 8 inputs are used alternately for the upper and lower end positions (see "Figure 21").

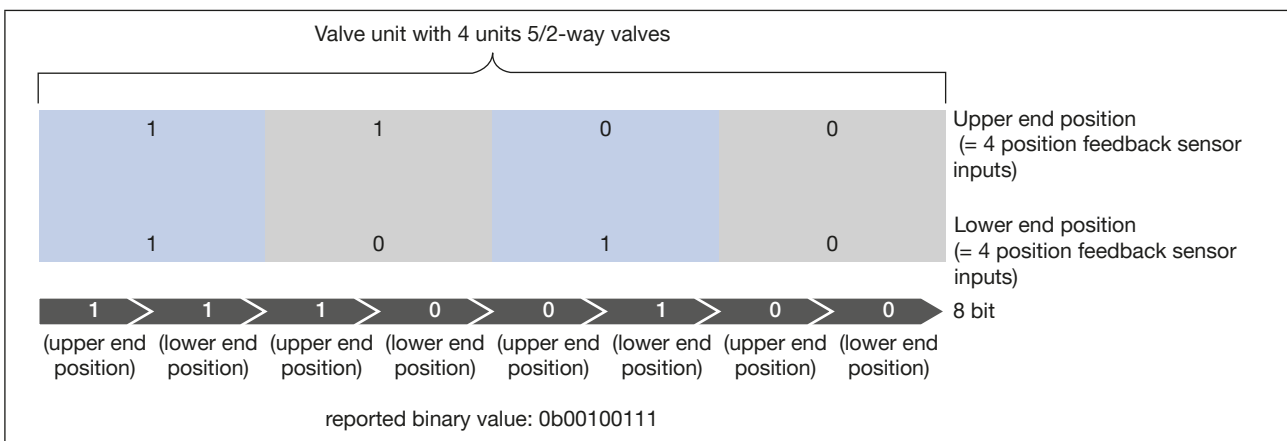

Figure 21: Example of changing end positions for a valve unit with 4 5/2-way valves

8.6 Valves type 6534 for safety-related shutdown, variant SIA

DANGER

Risk of injury due to unintentional movement of the actuators.

If the shut-off function is required to control safety-critical processes, hazardous movements of the actuators may be triggered when the switch-off function is faulty.

- ▶ Make sure the shut-off function is working properly before start-up.

WARNING

Risk of injury and property damage due to electrical faults.

If the connections for the safety-related shut-off are not connected correctly, there is a risk of injury due to uncontrolled behaviour of the plant.

- ▶ When using several SIA variant valves, connect each connection to an individual potential-free contact (mechanical switch or relay). **Never connect several contacts together under any circumstances!**
- ▶ Do not apply voltage to the connections (risk of damage to the valves).

Risk of injury due to sharp edges.

Sharp edges on the connection or on the contacts of the screw-type terminal can cause cuts.

- ▶ Wear suitable protective gloves.

Type 6534 valves for safety-related shut-off (SIA variant) are equipped with additional connection terminals. The circuit of a valve can therefore be interrupted by an external switch. Manual override is not required for these valve variants.

The technical data of the Type 6534 SIA variant valves corresponds to the data of the standard device.

To use the shut-off function, connect the connection to a potential-free contact (mechanical switch or relay).

The contact must be in the same control cabinet as the valve island; restrict the maximum cable length to 2 m.

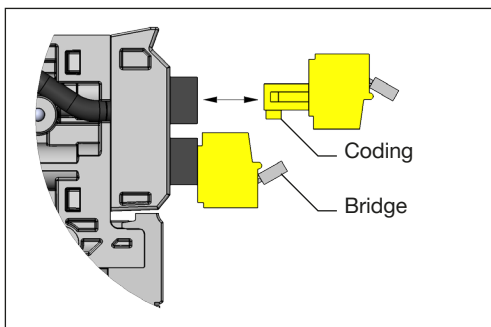

The yellow connection terminals are pluggable and can be removed to facilitate connection of a cable. With the exception of CF H, there are always 2 connection terminals. To avoid confusing the connections, the connection terminals are coded.

On delivery, the connection terminals are provided with a bridge to ensure the valve can be put into operation immediately. Remove the bridge before connecting a cable.

Connection terminals:	Pluggable screw-type terminal, 2-pole, coded wire cross-section (rigid or flexible) 0.14 mm ² ...1.5 mm ² (AWG 28...16)
Labelling connection terminals:	21 → connection terminal 2, pole 1 22 → connection terminal 2, pole 2 41 → connection terminal 4, pole 1 42 → connection terminal 4, pole 2
Required switching capacity of the contact:	0.5 A / 24 V DC

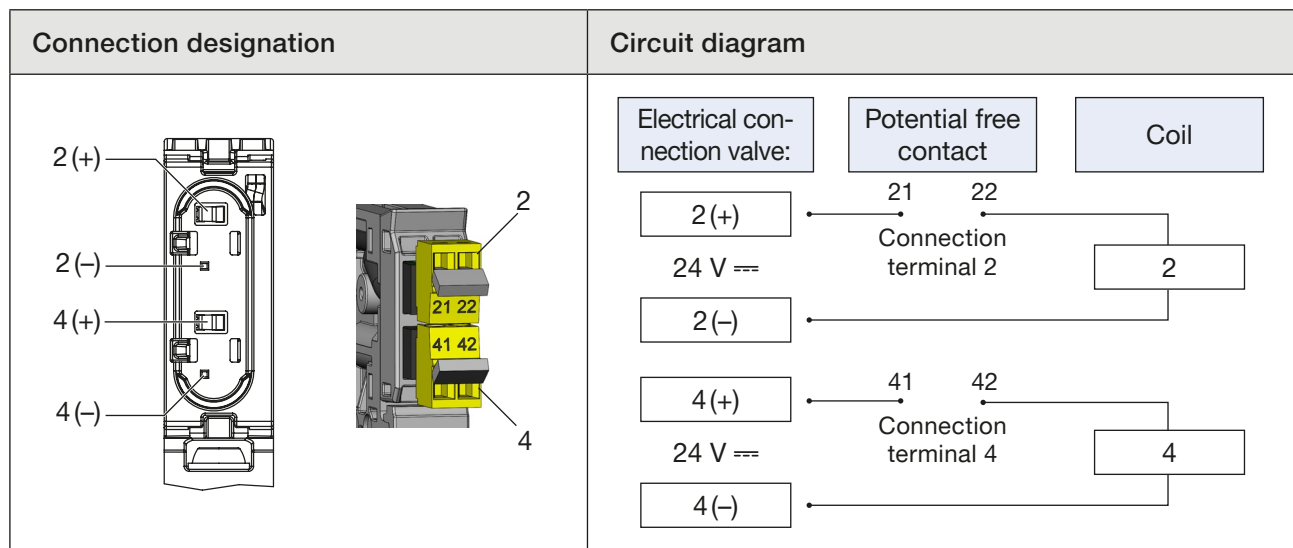

Figure 22: Connection designation and circuit diagram of all circuit functions available as variant SIA except for circuit function H (CF H see "Figure 23")

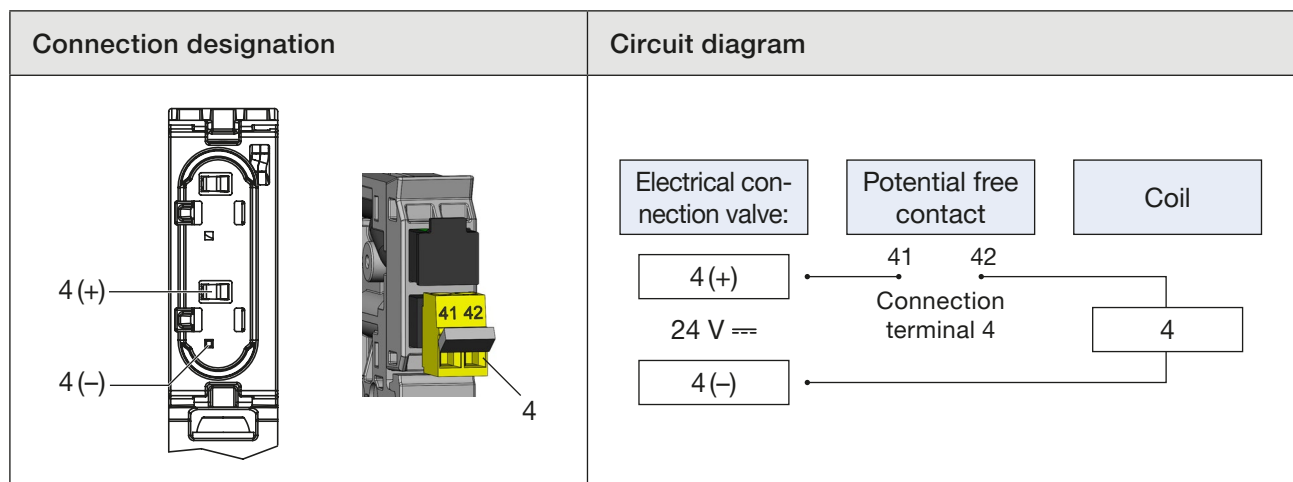

Figure 23: Connection designation and circuit diagram, variant SIA, circuit function H (CF H)

The labels 2 and 4 refer to the assignment to the respective working port.

8.7 Modular safety-related shutdown

! DANGER

Risk of injury due to unintentional movement of the actuators.

If the shutdown function "Module-based safety shutdown" is required to control safety-critical procedures, hazardous movements of the actuators may be triggered if the shutdown function is faulty.

- ▶ Make sure the shut-off function is working properly before start-up.

In spite of the activated shutdown function, actuators can be moved by manual override of the valves. If the shutdown function is used to control safety-critical procedures:

- ▶ Take suitable measures against unintentional actuation of the valves, e.g. by means of a lockable control cabinet or by blocking the manual overrides with the additional element "Locking HB" (see chapter "18.2.1 Additional element "Lock Manual Override"" on page 99).

! WARNING

Risk of injury and property damage due to electrical faults.

If the connections for module-based safety shutdown are not connected correctly, there is a risk of injury due to uncontrolled behaviour of the plant.

- ▶ If several valve units are to be shut down in a safe manner, connect each connection to an individual potential-free contact (mechanical switch or relay). **Never connect several contacts together under any circumstances!**
- ▶ Do not supply voltage to the connections for module-based safety shutdown (risk of damaging the valves).

Risk of injury due to sharp edges.

Sharp edges on the connection or on the contacts of the 12-pole spring-loaded terminal can cause cuts.

- ▶ Wear suitable protective gloves.

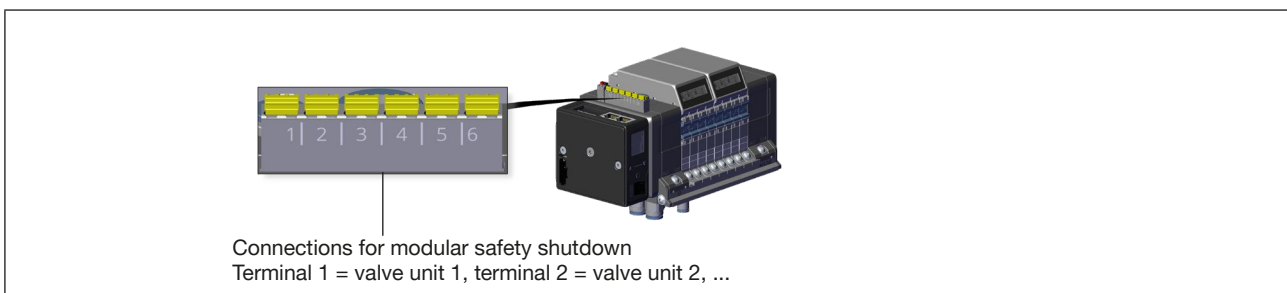

Figure 24: Port for module-based safety shutdown

The interface boards for module-based safety shutdown are additionally equipped with a 12-pole spring-loaded terminal. As a result, the electric circuit of a valve unit (4 pneumatic valves) can be interrupted by an external switch, e.g. to implement functions such as "Central system off" or to deactivate actuators group by group.

The interruption will immediately cause a single-pole interruption of the common supply to all valves of the valve unit (see "Figure 25").

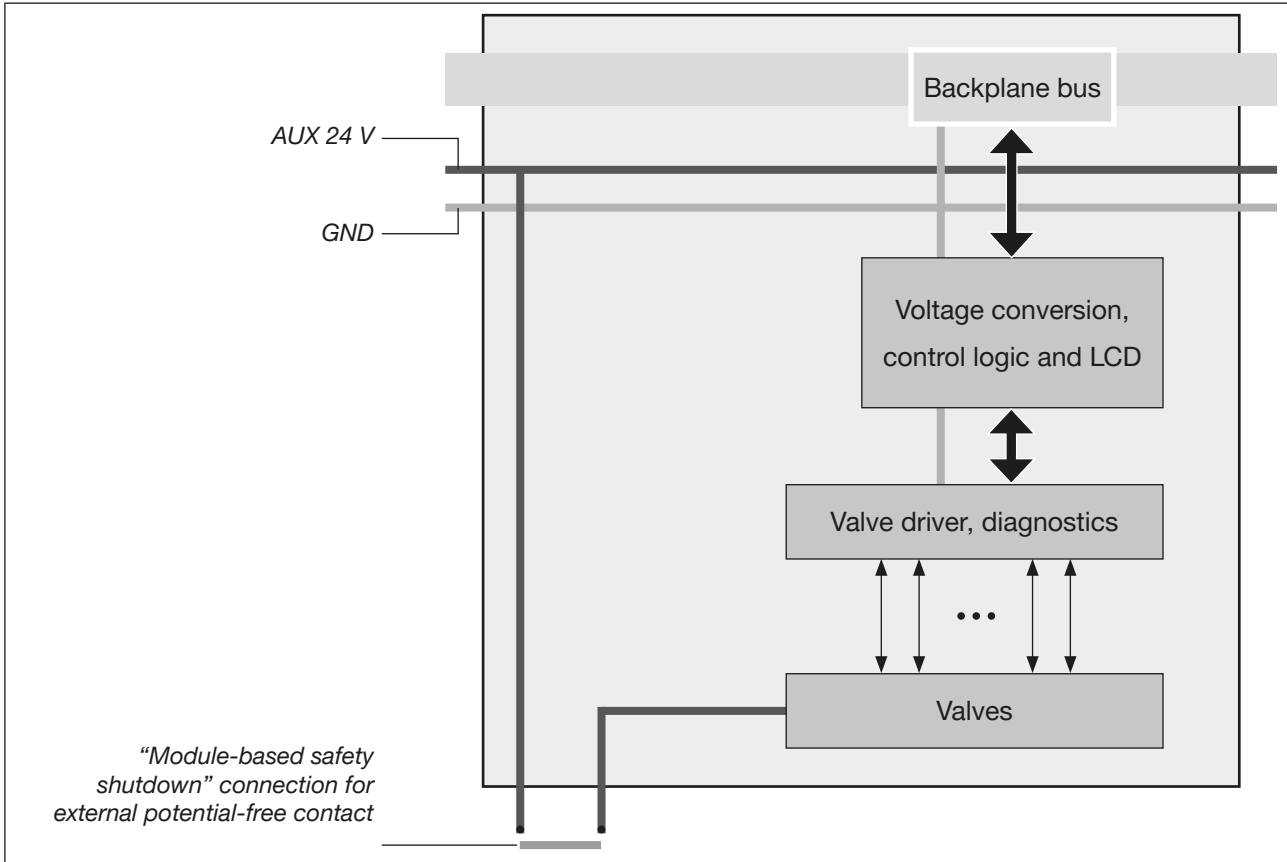

Figure 25: Schematic representation of a valve unit with shutdown function "Module-based safety shutdown"

To use the shut-off function, connect the connection to a potential-free contact (mechanical switch or relay). The contact must be in the same control cabinet as the valve island; restrict the maximum cable length to 2 m.

Connection	Pluggable screw-type terminal ¹¹ , 12-pole cable cross-section (rigid or flexible) 0.14 mm ² ...1.5 mm ² (AWG 26...16)
Required switching capacity of the contact	1.5 A / 24 V DC

¹¹⁾ On delivery, the spring-loaded terminal is provided with a bridge so that the electronic basic module can be put into operation immediately. Remove the bridge before connecting a cable.

9 PNEUMATIC CONNECTION

! DANGER

Risk of injury from high pressure.

- ▶ Secure the actuators against shifting before working on the device or plant.
- ▶ Switch off the pressure before working on the device or plant. Vent or empty the lines.

Risk of injury if the pneumatic connection is incorrect.

- ▶ Only trained specialists are allowed to make the pneumatic connection.
- ▶ Make the pneumatic connection only with a suitable tool.

! CAUTION

Danger due to loud noises.

- ▶ Seal unused connections with sealing plugs (e.g. for 5/2-way valves).

! Recommendation

- Only use Bürkert sealing plugs (see chapter “29 Accessories” on page 136). These sealing plugs are tested under laboratory conditions. If plugs from other manufacturers are used, the service life of the device may be limited.
- We recommend the use of original Bürkert accessories only (see chapter “29 Accessories” on page 136).

Synthetic hoses for pneumatics

When using hoses from other manufacturers, make sure the hose diameter remains within the tolerance of ± 0.1 mm.

9.1 Assignment of the pneumatic ports

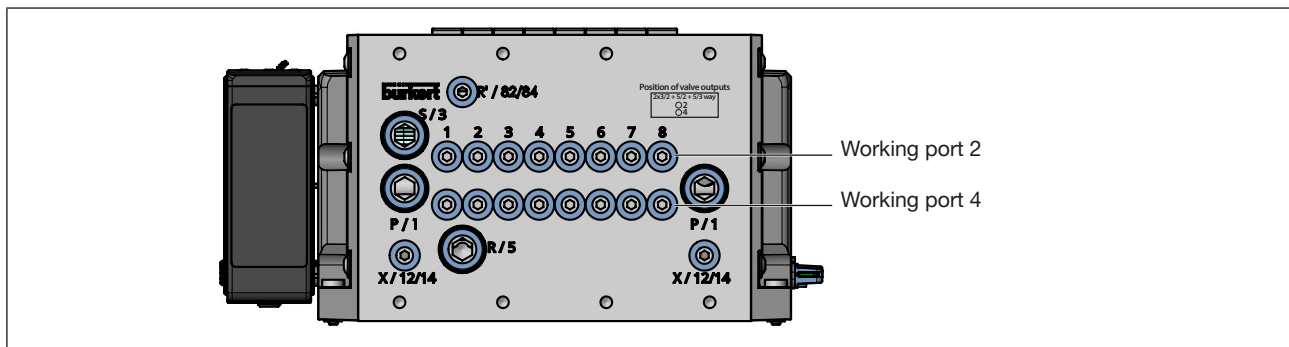

Figure 26: Pneumatic connections valve island

Connection	Assignment	
1...8	Valve slots	
P / 1	Pressure port	
S / 3	Exhaust ports	
R / 5		
R' / 82/84	Exhaust port for auxiliary pilot air	With the Basic variant, the equipment of the connections for auxiliary pilot air can vary.
X / 12/14	Pressure port for auxiliary pilot air	

Figure 27: Terminal assignment valve island

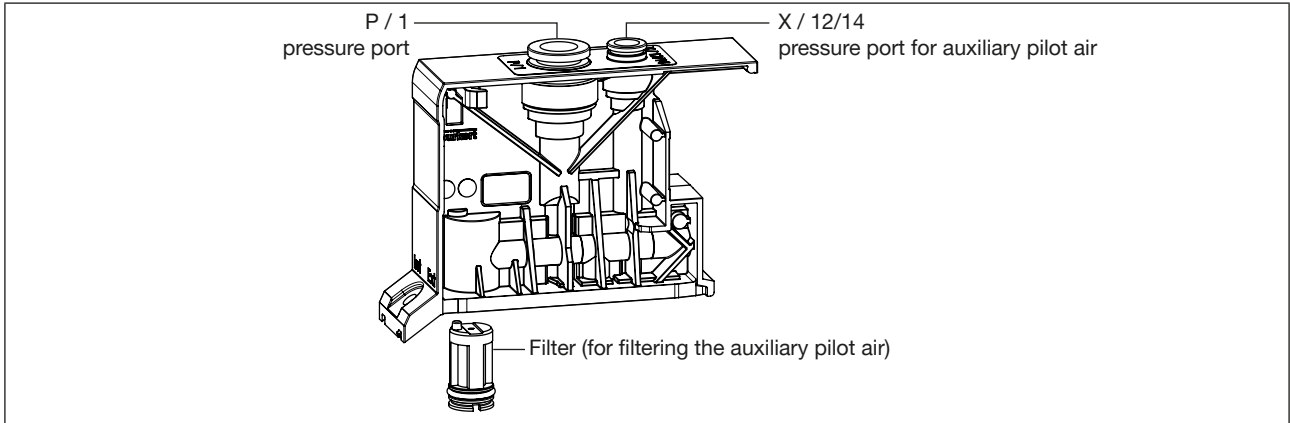

Figure 28: Pneumatic connections connection module

9.1.1 External and internal auxiliary pilot air

The seals of the connection module are already installed in the delivery state. Should it be necessary to change the supply of the auxiliary pilot air, this can be done by turning the seal. It is essential to observe the following note!

NOTE

Internal short circuit between the auxiliary pilot air and the pilot pressure.

To avoid an internal short circuit, the seals of the connection modules must be positioned the same (external or internal supply of auxiliary pilot air). Mixing the external or internal supply is not permitted.

► Never mix the external or internal supply.

! The X port always has to be connected for an external supply.

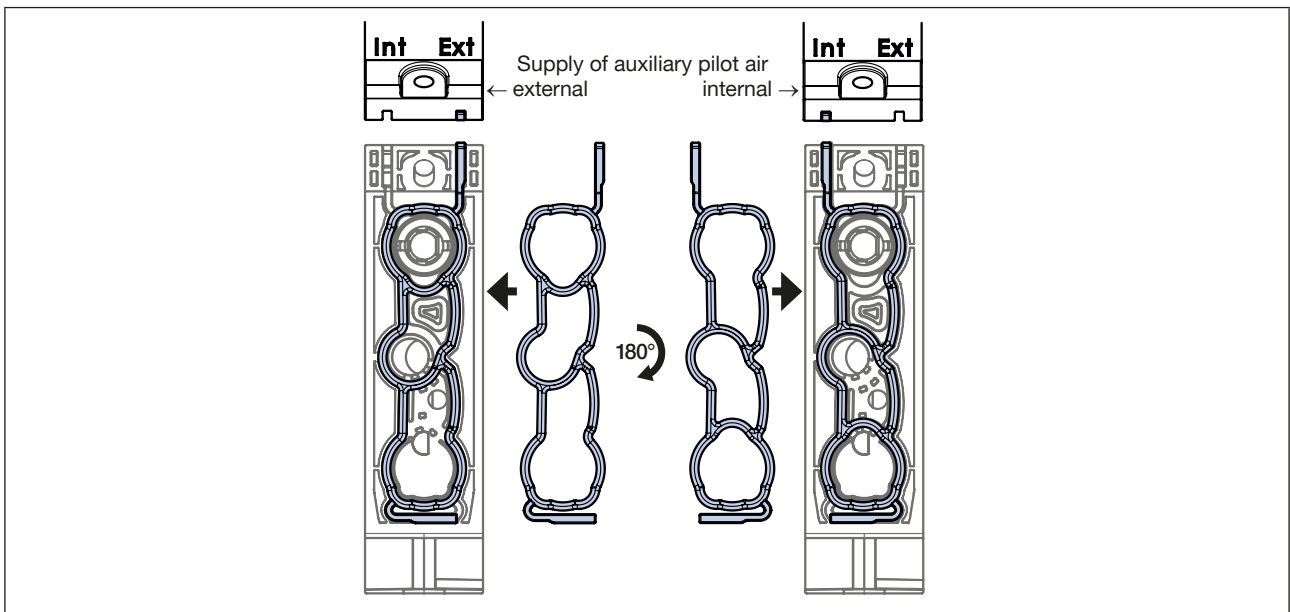

Figure 29: The valves are set to external or internal supply of auxiliary pilot air by turning (sliding over) the seal by 180°. The type of feed must always be the same within the valve island!

MAN 1000338074 EN Version: AF Status: RL (released | freigegeben) printed: 23.05.2024

9.2 Pneumatic connection assignment

Valve unit with 4 double valves

BM1_Valves							
Bit 0	Bit 1	Bit 2	Bit 3	Bit 4	Bit 5	Bit 6	Bit 7
Valve 1	Valve 2	Valve 3	Valve 4	Valve 5	Valve 6	Valve 7	Valve 8
Pneumatic connection							
2	4	2	4	2	4	2	4

Table 7: Example for the assignment of the bits for double valves

If there are single valves in a valve unit, the next bit is skipped after a single valve (see following example).

Valve unit with 2 single valves and 2 double valves

BM1_Valves					
2 single valves			2 double valves		
Bit 0	Bit 2	Bit 4	Bit 5	Bit 6	Bit 7
Valve 1	Valve 3	Valve 5	Valve 6	Valve 7	Valve 8
Pneumatic connection					
4	4	2	4	2	4

Table 8: Example for the assignment of the bits for 2 single valves and 2 double valves

9.2.1 Allocation of the valve outputs to the pneumatic connections of the valve island

Valve type	Pneumatic connection	
	Valve outlet	AirLINE Quick
2x3/2-way	Position of valve outputs 	
5/2-way		
5/3-way		

10 INTEGRATION INTO THE CONTROL ENVIRONMENT

10.1 Start-up files and description of the process data and parameters

The start-up files required by the project planning software are available on the Internet.



Download the start-up files from:

country.burkert.com → Type 8652 → Software → Device Description Files.zip

You will also find the descriptions of the start-up files in the zip file.

→ Use the latest start-up file from the "01_Standard" folder (exception: see Chapter "10.2").



The description of the CANopen standard objects can be found under:

country.burkert.com → Type 8652 → Operating instructions → "CANopen network configuration"

10.2 PLC compatibility

If new devices are to be operated with the start-up files of an older software version, e.g. because a replacement device is to be used in an existing automation system, this can be done without issue by converting the PLC compatibility.



The currently installed software is shown under **Maintenance** > **SW version** on the display of the fieldbus gateway.

Convert compatibility mode via the display of the fieldbus gateway:

["12.4 Converting compatibility mode" on page 75](#)

Convert the compatibility mode via the Bürkert Communicator:

["16.2.6 Converting compatibility mode" on page 88](#)

10.2.1 Compatibility mode and start-up files



Download the start-up files from:

country.burkert.com → Type 8652 → Software → Device Description Files.zip

In "Device Description Files.zip" there are sub-folders "01_Standard" and "02_Extension_Modules" in each fieldbus folder (see Chapter ["16.11 Using Extension Modules \(EM\)"](#)).

Please note the release notes in the respective folder in order to use the appropriate version of the start-up file.

10.2.2 Error alerts concerning PLC compatibility

Error code	Description	Troubleshooting
51/103	No or incorrect mapping file present.	<ul style="list-style-type: none"> If extension modules were used, perform the Extension module settings wizard again. General settings > Parameter > Extension module settings Use a separate gateway configuration if one has been created.
51/400	The master attempted to connect a faulty module/sub-module.	<ul style="list-style-type: none"> The version of the start-up file does not match the device (see chapters “10.2.1”). The controller settings do not match the device.

10.3 Commissioning a PROFINET device with Siemens TIA Portal

→ Import the start-up file into the hardware catalogue of the tool. The start-up files of version V2.0 were used in the illustrations shown.

ATTENTION! There are different commissioning files for PROFINET and PROFINET S2. The procedure for commissioning is the same for both file variants.

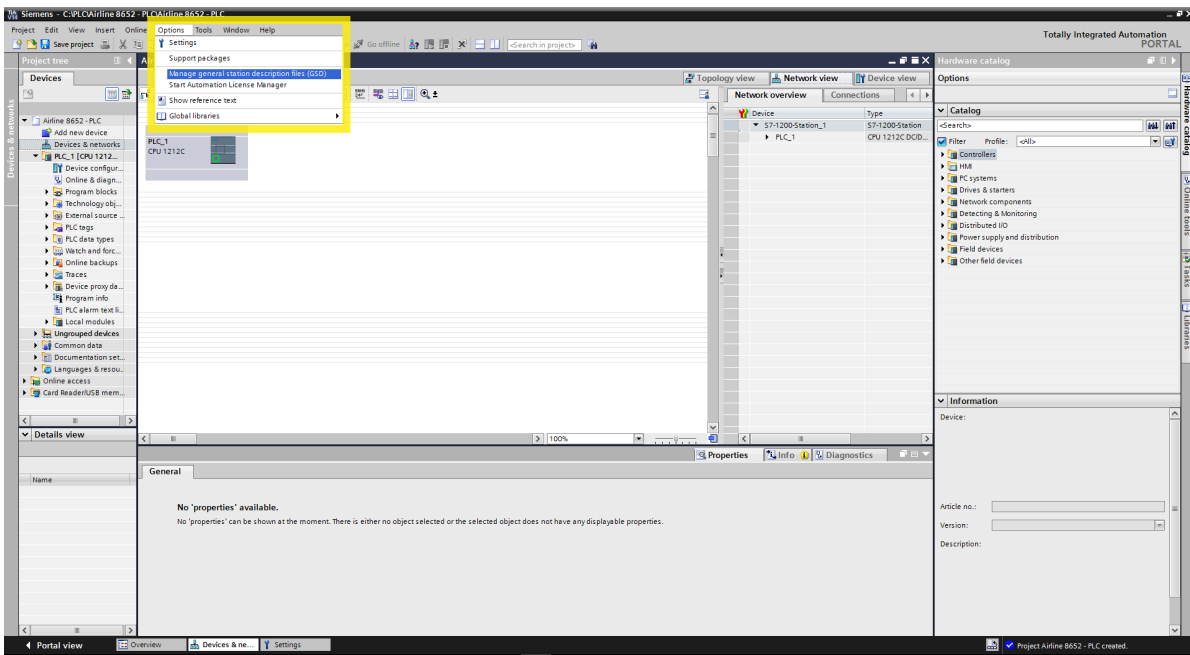

→ Select the device in the hardware catalogue and drag and drop it into the work area.

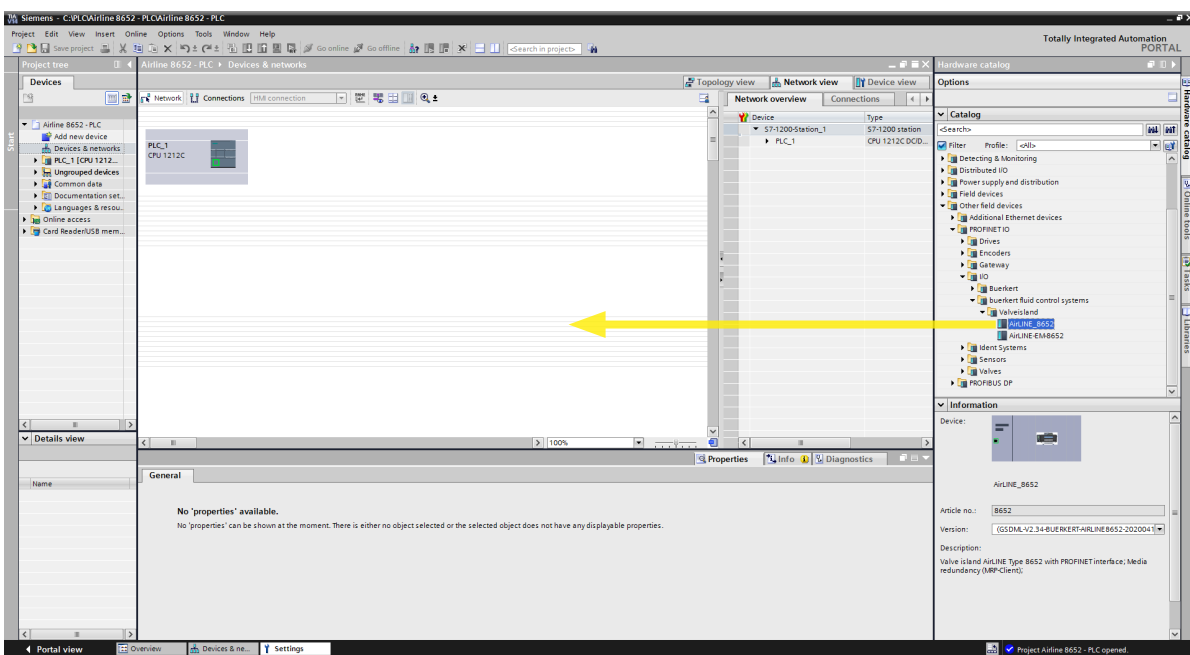

→ Assign a PROFINET interface to the device.

→ Double-click the device in the work area. This opens the device overview.

On the right, in the "Catalogue" menu, you will find the modules:

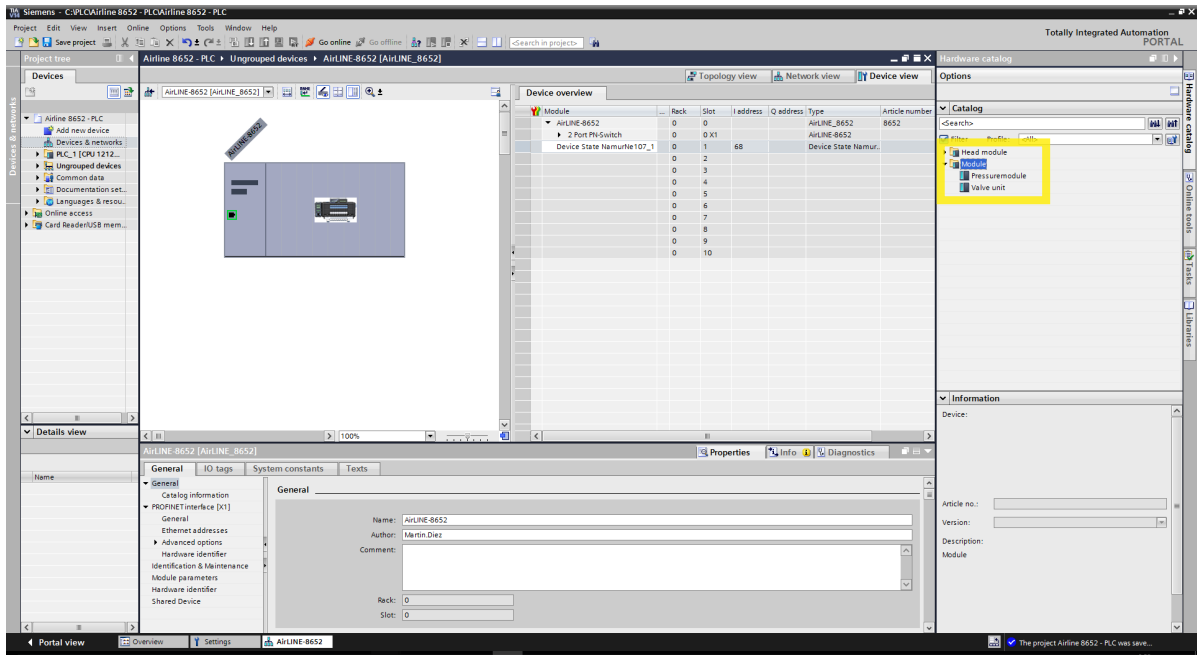

→ Assign the modules to the respective slot by double-clicking or by drag and drop. **Map the real structure of the valve island from left to right.** Pressure measuring modules* (if available) and valve units must be assigned.

In the screenshot below, the modules of a valve island with 1 pressure measurement module and 3 subsequent valve units are assigned to the slots as an example.

*) A connection module with an integrated pressure sensor is referred to as a "pressure measuring module".

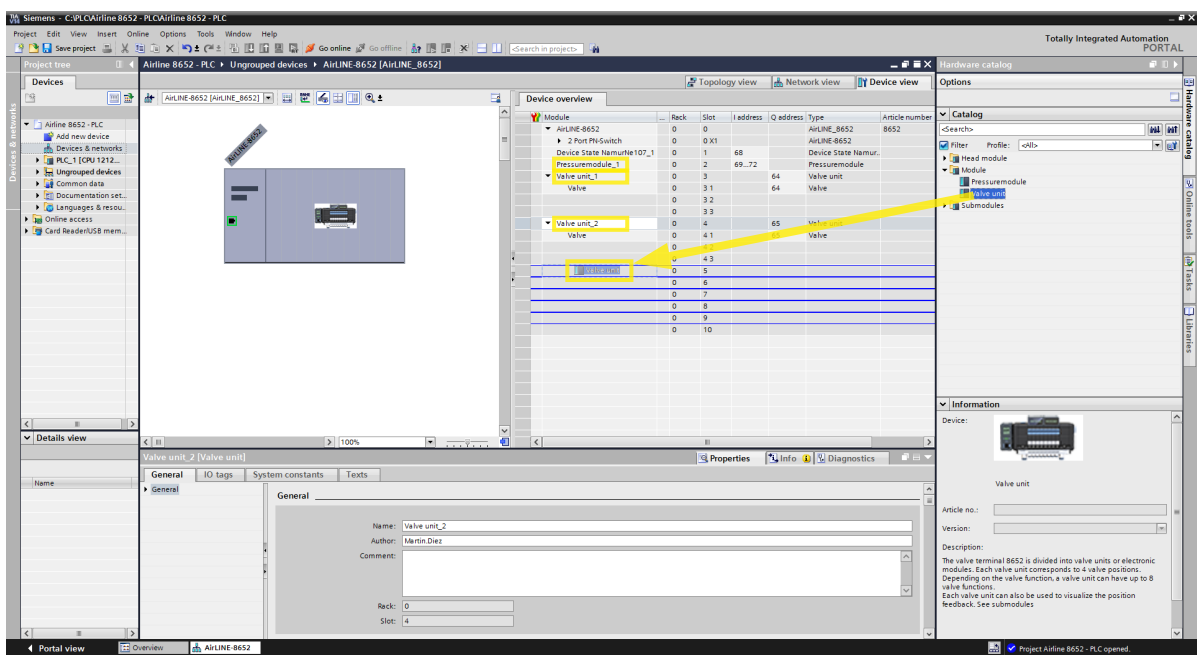
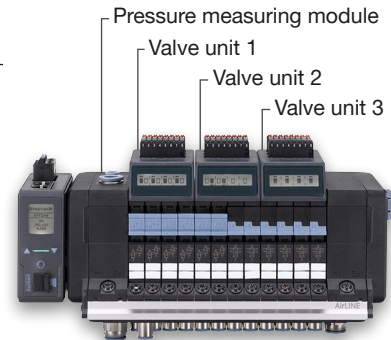

→ Then configure the position feedback sensor source for each valve unit.
To do this, drag the position feedback sensor used from the submodules to the corresponding position in the device overview.

In the device overview, Subslot 1 corresponds to the valve,
Subslot 2 to the position feedback sensor of the upper end position,
Subslot 3 to the position feedback sensor of the lower end position.

If no position feedback sensor is dragged into the device overview, the feedback sensor on the valve units is deactivated.



If “feedback alternating” is selected in Subslot 2, no feedback device should be configured in Subslot 3.

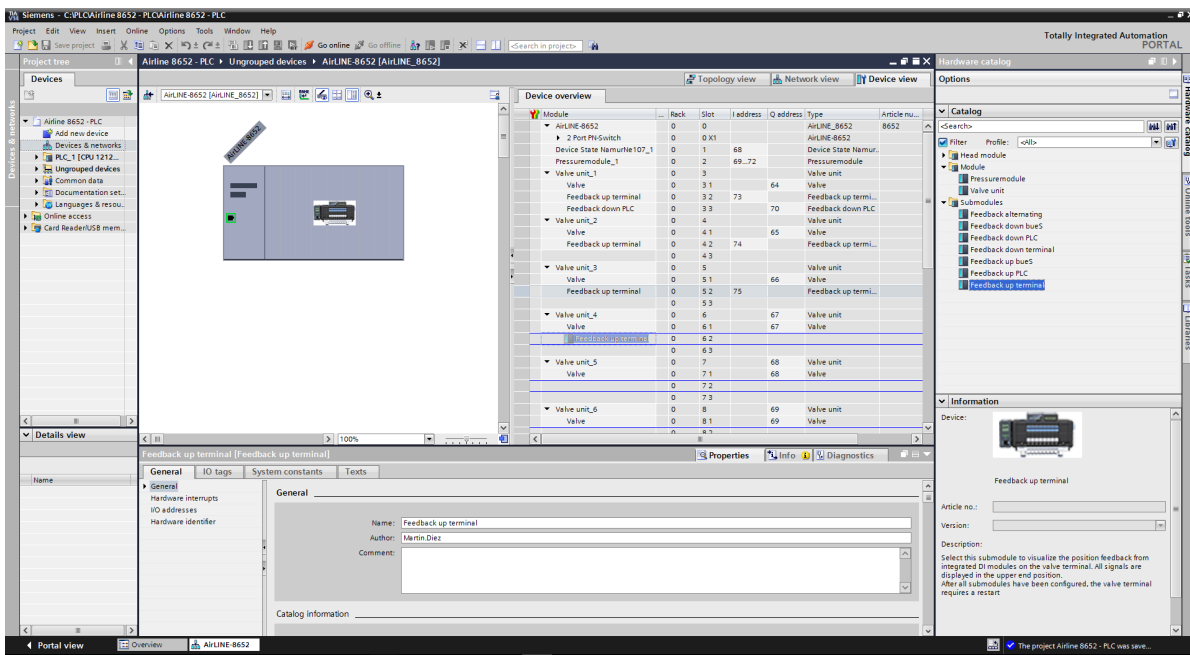

Figure 30: The example shows the real structure of a valve island with 1 pressure sensor and 6 connected valve units, including position feedback sensor sources.



To accept this setting, the valve island restarts at the time of the first connection to the controller.

10.4 Commissioning a PROFIBUS DPV1 device with Siemens TIA Portal

→ Import the start-up file into the hardware catalogue of the tool. The start-up files of version V2.0 were used in the illustrations shown.

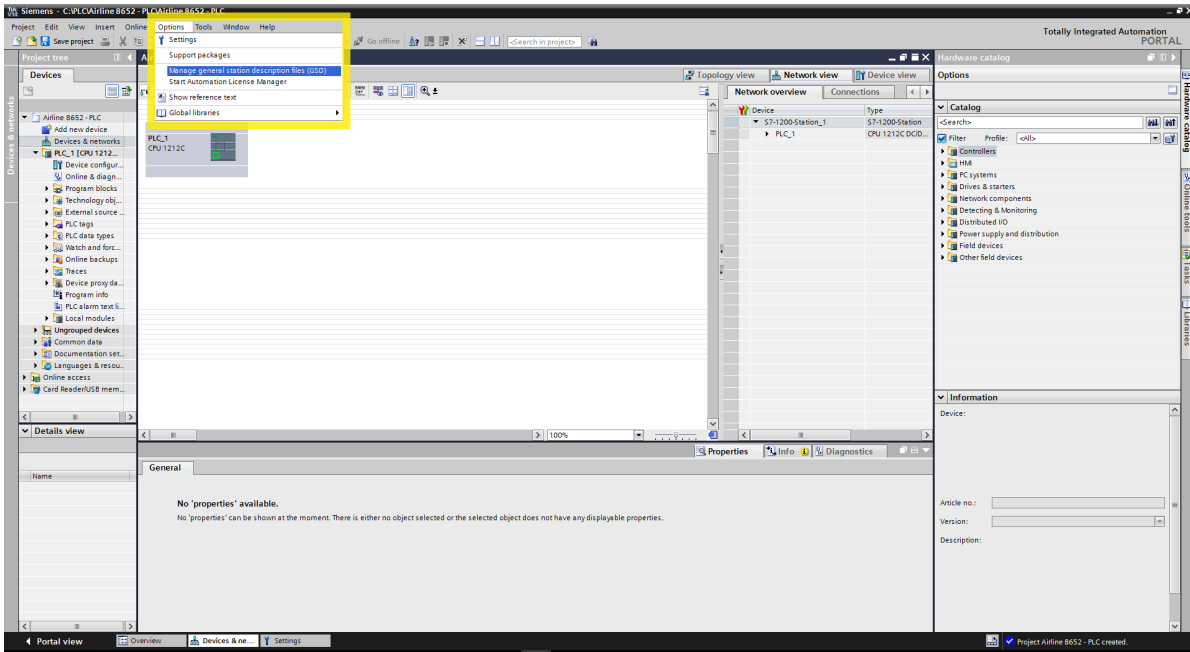

→ Select the device in the hardware catalogue and drag and drop it into the work area.

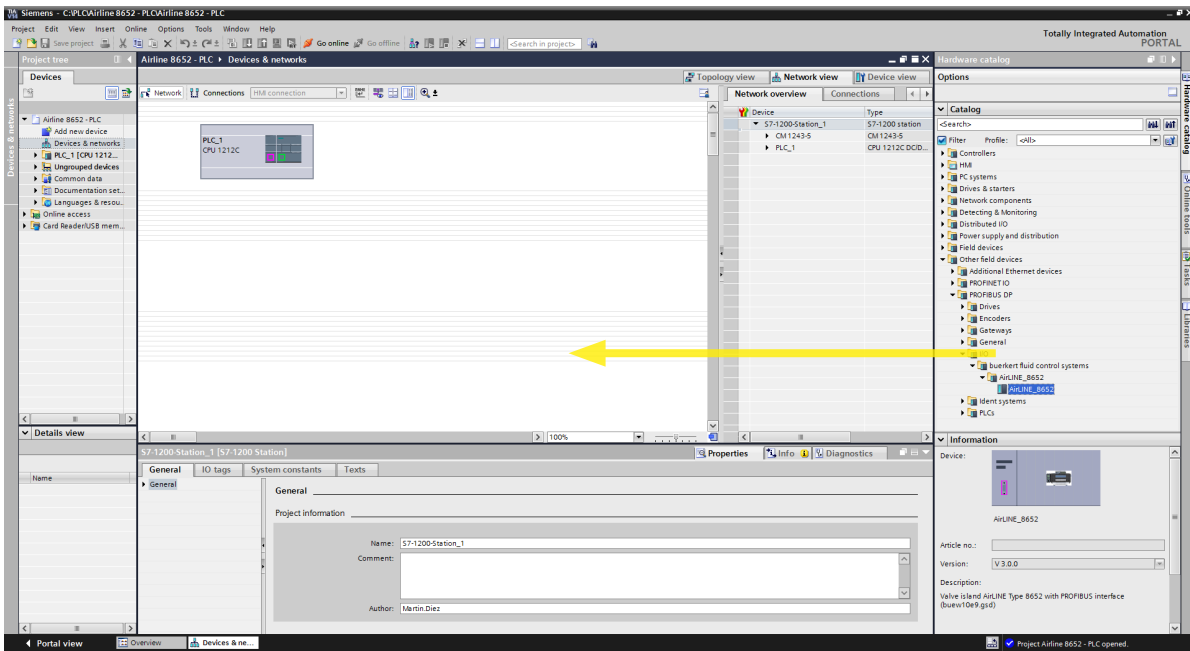

→ Assign a PROFIBUS DPV1 interface to the device.

→ Double-click the device in the work area. This opens the device overview.

On the right, in the "Catalogue" menu, you will find the modules:

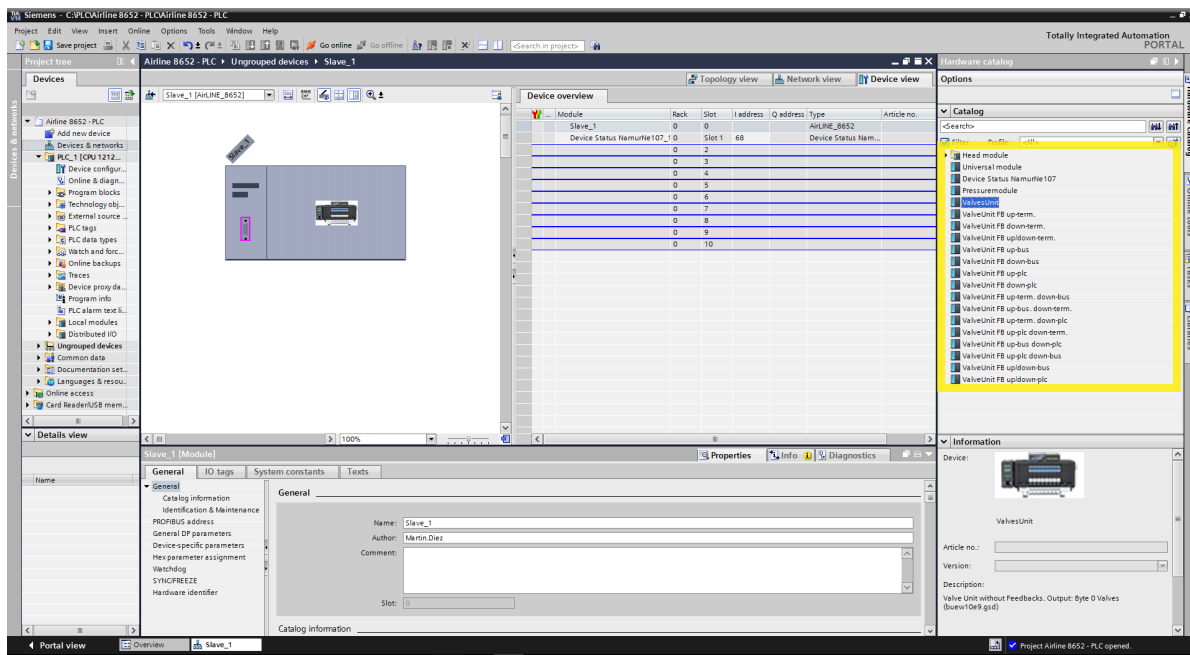

→ Assign the modules to the respective slot by double-clicking or by drag and drop. **Map the real structure of the valve island from left to right.** Pressure measuring modules (if present) and valve units must be assigned. A connection module with an integrated pressure sensor is referred to as a “pressure measurement module”.

Example for the assignment of the modules:

The valve island shown on the right has been configured in the following screenshot. From left to right, this valve island has 1 pressure measurement module (Pressure module_1) and 3 valve units.

In our example, the valve units are equipped with digital inputs. The digital inputs report the upper end position of the actuator, the lower end position is reported via the controller.

The “ValveUnit FB up-term. down-plc ” is therefore assigned to the corresponding slot for each valve unit (see also “Table 9”).

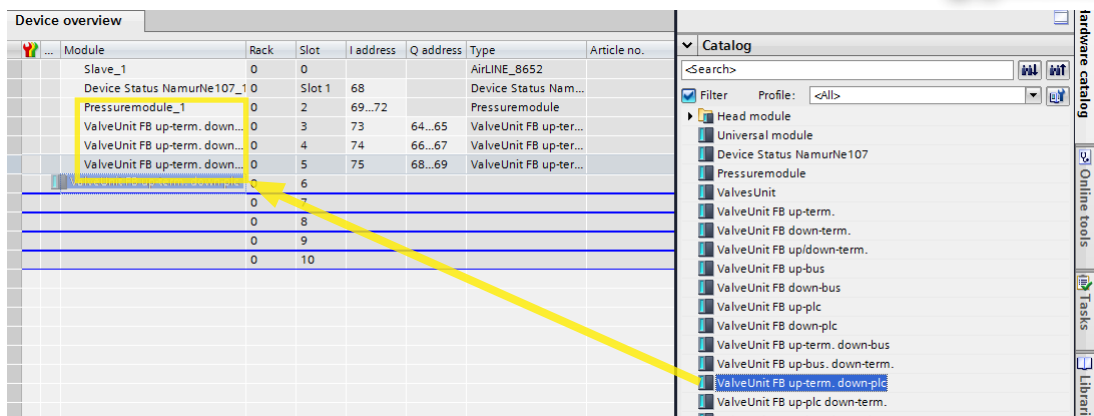
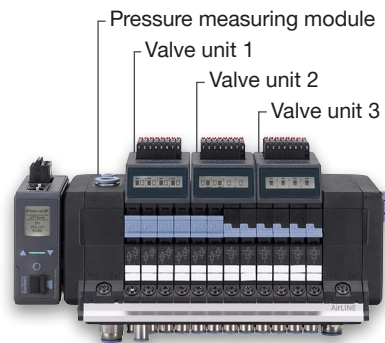

! To accept this setting, the valve island restarts at the time of the first connection to the controller.

MAN 1000338074 EN Version: AF Status: RL (released | freigegeben) printed: 23.05.2024

Module in the catalogue of the TIA Portal	Set position feedback sensor source
ValvesUnit	No position feedback sensor sources are set
ValveUnit FB up-term.	Upper end position: digital inputs valve island Lower end position: not used
ValveUnit FB down-term.	Lower end position: digital inputs valve island Upper end position: not used
ValveUnit FB up/down-term.	Upper / lower end position: digital inputs valve island (changing end position, single valve)
ValveUnit FB up-bus	Upper end position: via bÜS network Lower end position: not used
ValveUnit FB down-bus	Lower end position: via bÜS network Upper end position: not used
ValveUnit FB up-plc	Upper end position: via PLC Lower end position: not used
ValveUnit FB down-plc	Lower end position: via PLC Upper end position: not used
ValveUnit FB up-term. down bus	Upper end position: digital inputs valve island Lower end position: via bÜS network
ValveUnit FB up-bus down-term.	Upper end position: via bÜS network Lower end position: digital inputs valve island
ValveUnit FB up-term. down-plc	Upper end position: digital inputs valve island Lower end position: via PLC
ValveUnit FB up-plc down-term.	Upper end position: via PLC Lower end position: digital inputs valve island
ValveUnit FB up-bus down-plc	Upper end position: via bÜS network Lower end position: via PLC
ValveUnit FB up-plc down-bus	Upper end position: via PLC Lower end position: via bÜS network
ValveUnit FB up / down bus	Upper and lower end position: via the bÜS network
ValveUnit FB up/down-plc	Upper and lower end position: via PLC

Table 9: Modules for valve units in the catalogue of the TIA portal

10.5 Commissioning an EtherNet/IP device with Rockwell Logix Designer

To configure the Type 8652 valve island in Rockwell Studio 5000 Logix Designer, the add-on profile “AOP” is required. Alternatively, commissioning using the EDS file is also possible.

The AOP is already included in V35 and later versions of the Logix Designer software for the Rockwell Studio 5000 Logix Designer.



A zip file is available for earlier versions of Logix Designer under:
country.burkert.com → Type 8652 → Software → Add-On-Profile AOP

10.5.1 Commissioning with Add-On-Profile (AOP)

Offline settings

Configure the settings offline first, then connect the valve island to the controller.

The settings will be copied to the controller as soon as the valve island is connected to it.

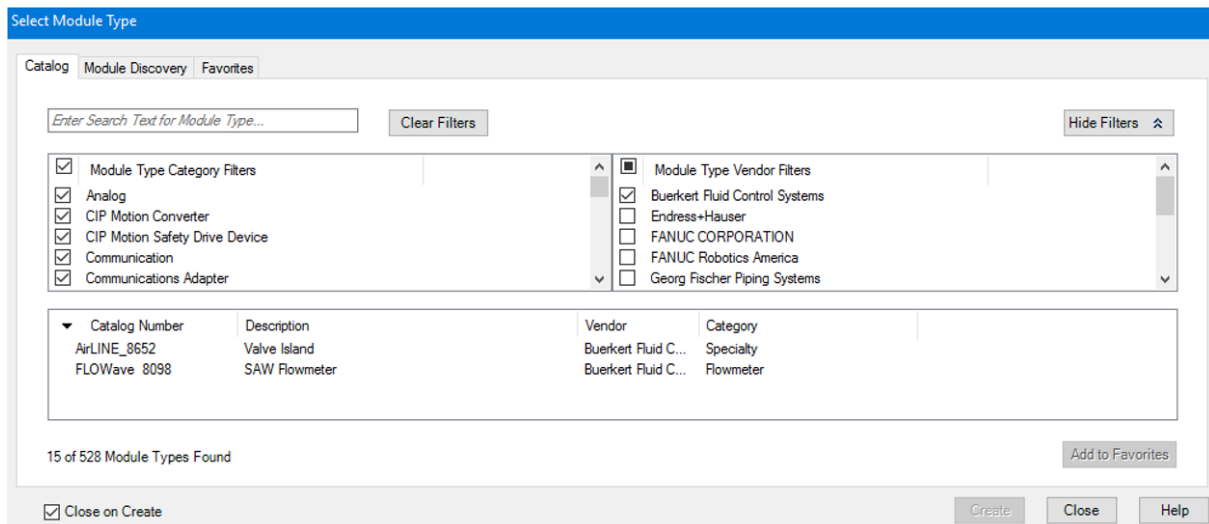

→ Select the device in the **Catalog** tab.

→ To simplify the search for the device: – select the filter “Buerkert Fluid Control Systems” or – enter the term “AirLINE” in the search field at the top left.

→ Confirm with **Create**. This opens the **New Module** window.

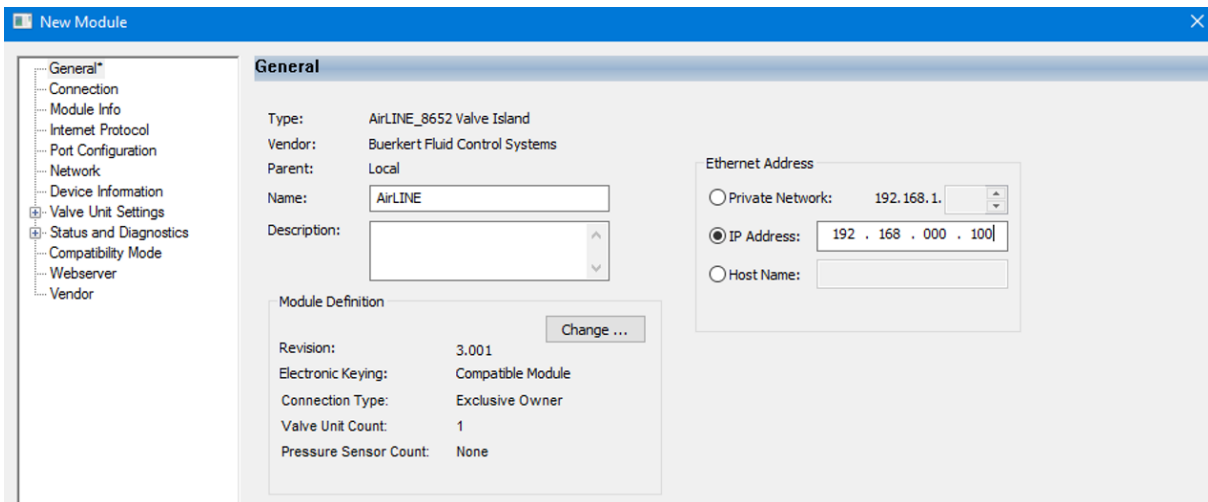

→ Enter **Name** and **IP Address** then click on **Change**.

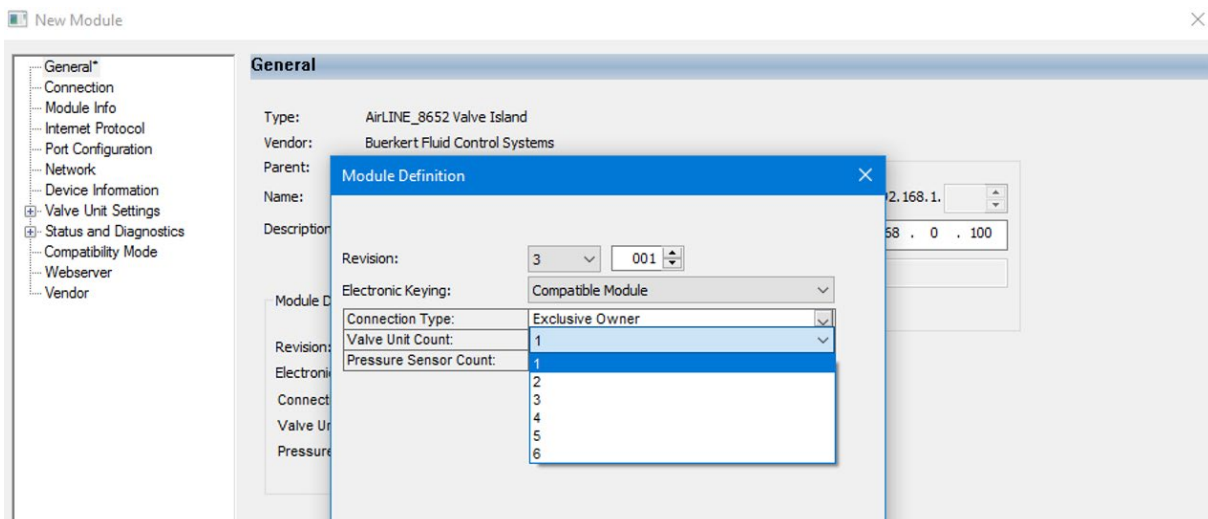

→ In the **Valve Unit Count** field, enter the number of available valve units.

→ In the **Pressure Sensor Count** field, enter the number of available pressure sensors.

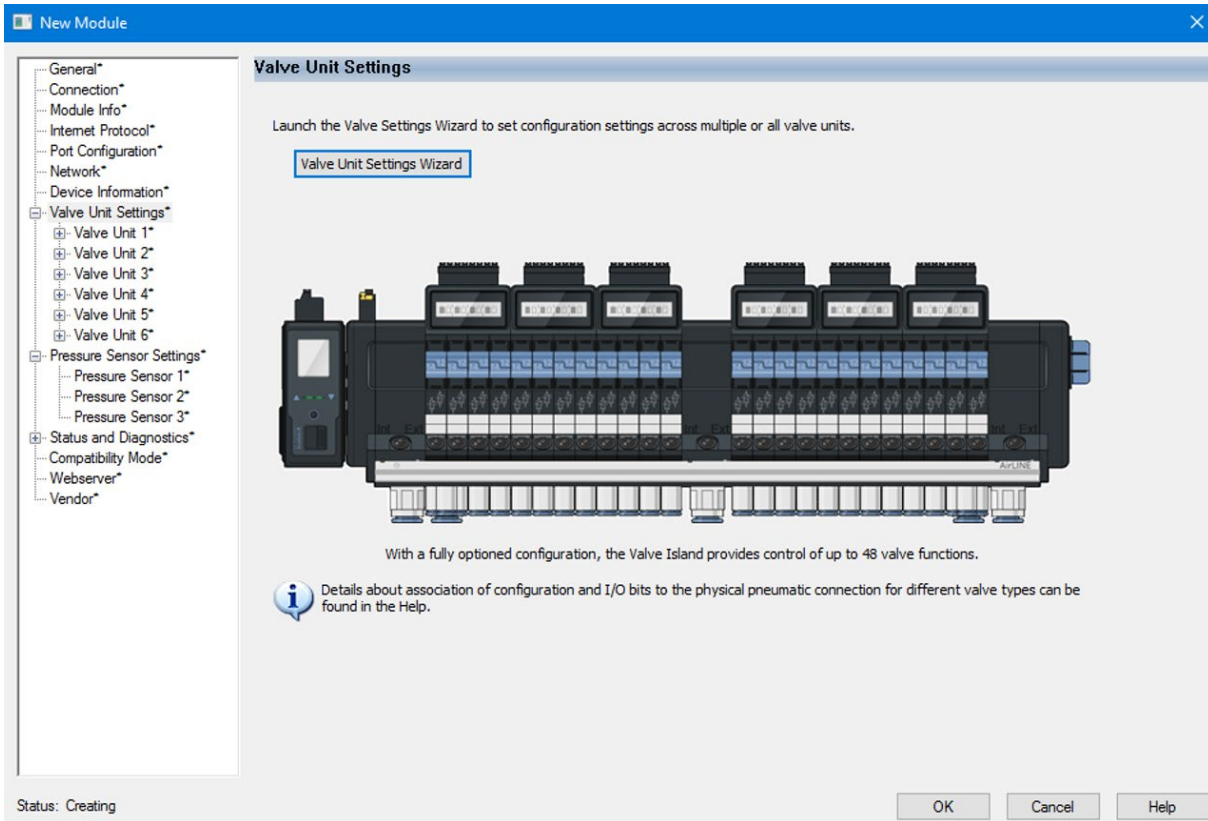

In the **Valve Unit Settings** and **Pressure Sensor Settings** fields, all settings will be used that have been copied when a connection was established with the valve island.

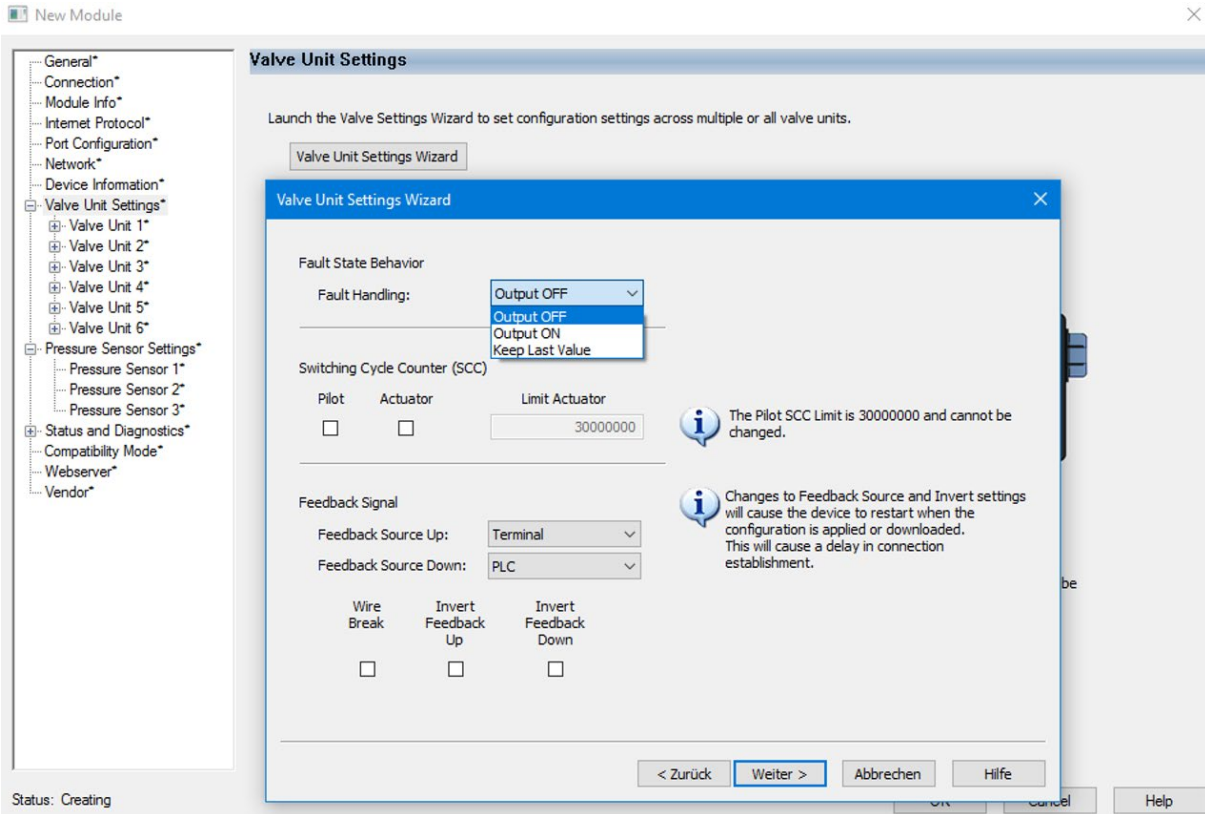

Settings such as error behaviour, switching cycle counter activation, and the position feedback sources setting can be set using the wizard and applied to multiple valve units.

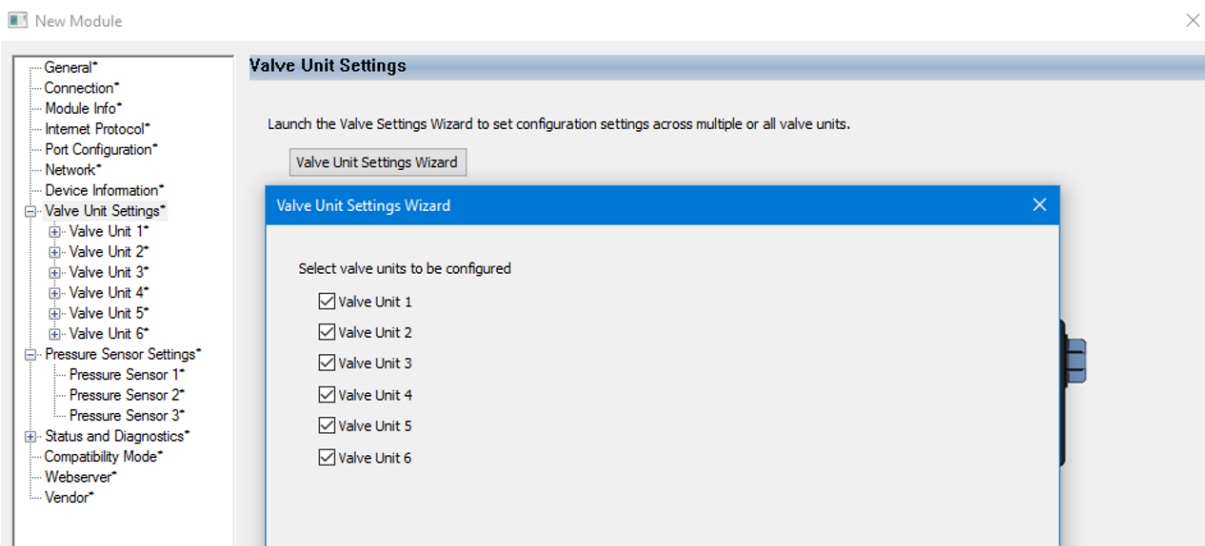

→ Then select the valve units for which the settings are to be used.

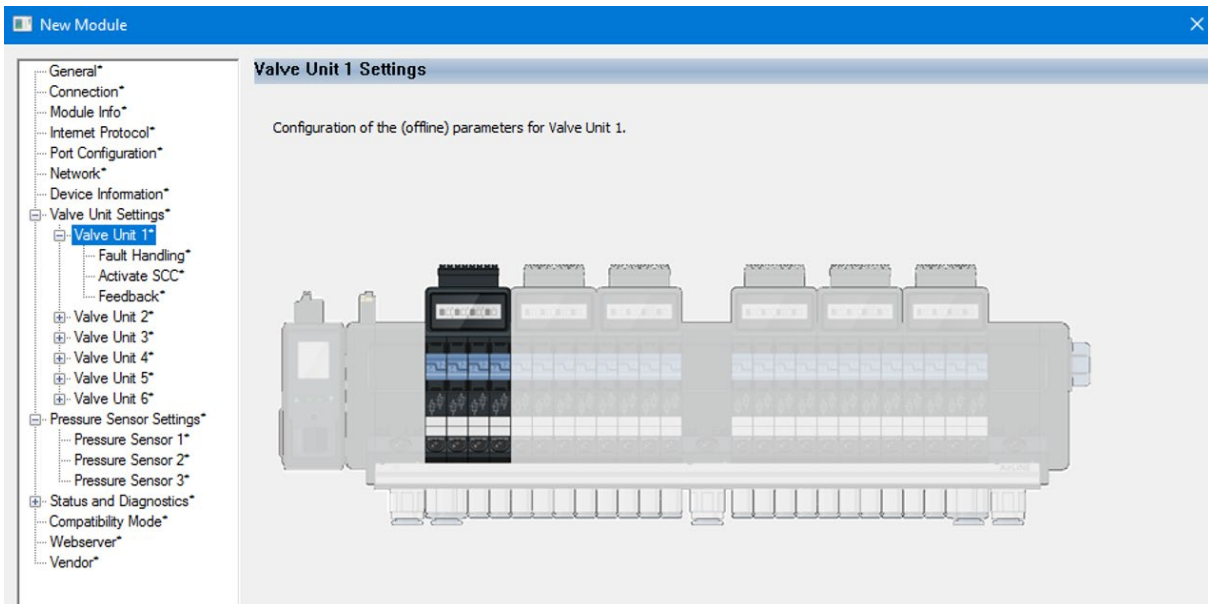

These settings can also be set separately for each unit and checked...

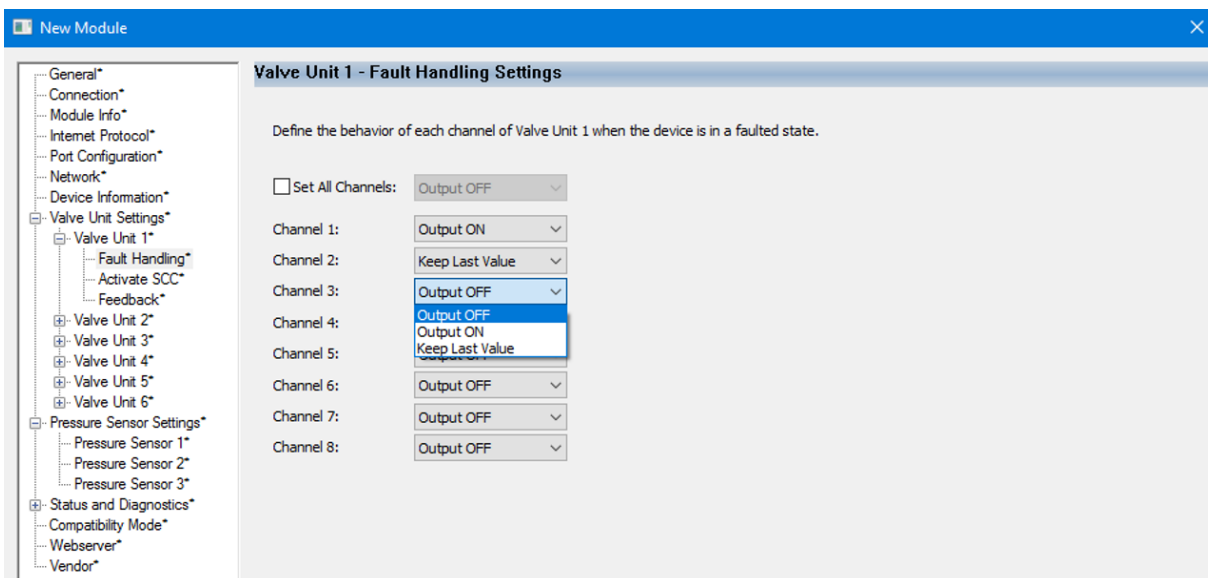

...and different settings can be set for each valve.

MAN 1000338074 EN Version: AF Status: RL (released | freigegeben) printed: 23.05.2024

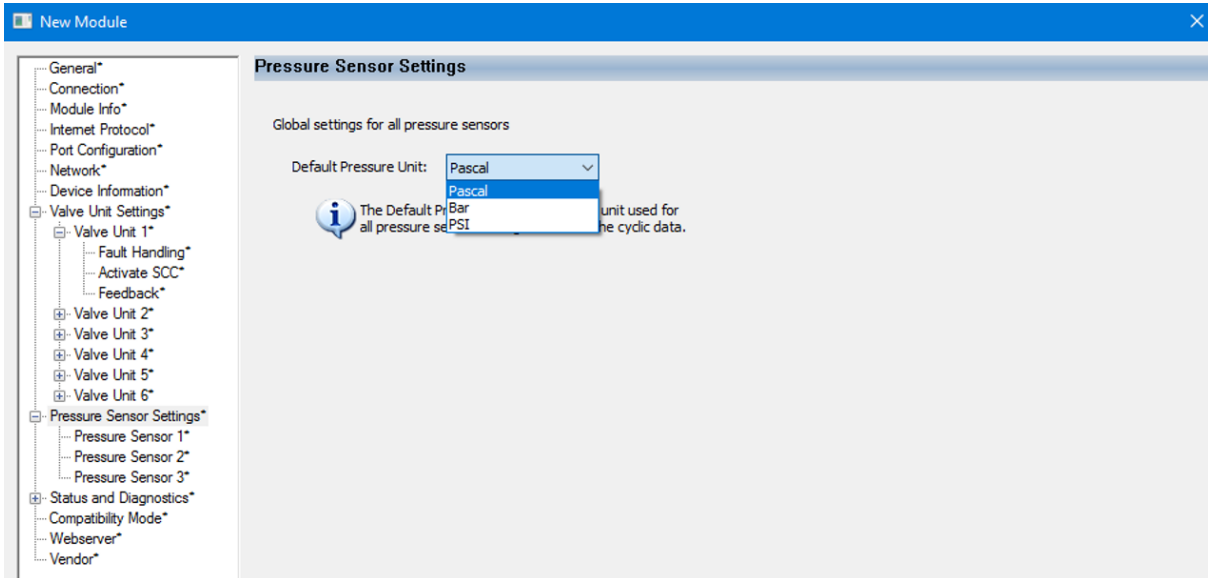

When pressure sensors are used, the units for the pressure value can be set. This setting applies to all pressure sensors, measured values and limit values.

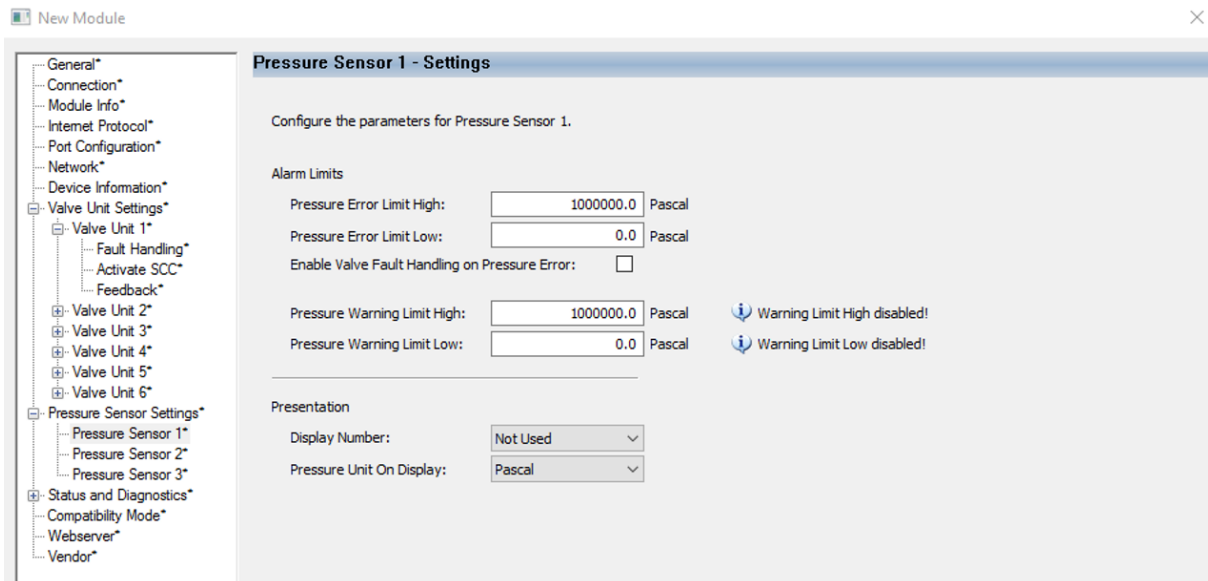

For each pressure sensor, the alarm limits for errors and warnings, the display of the pressure value on the display (of a valve unit), and the pressure value unit can now be set.

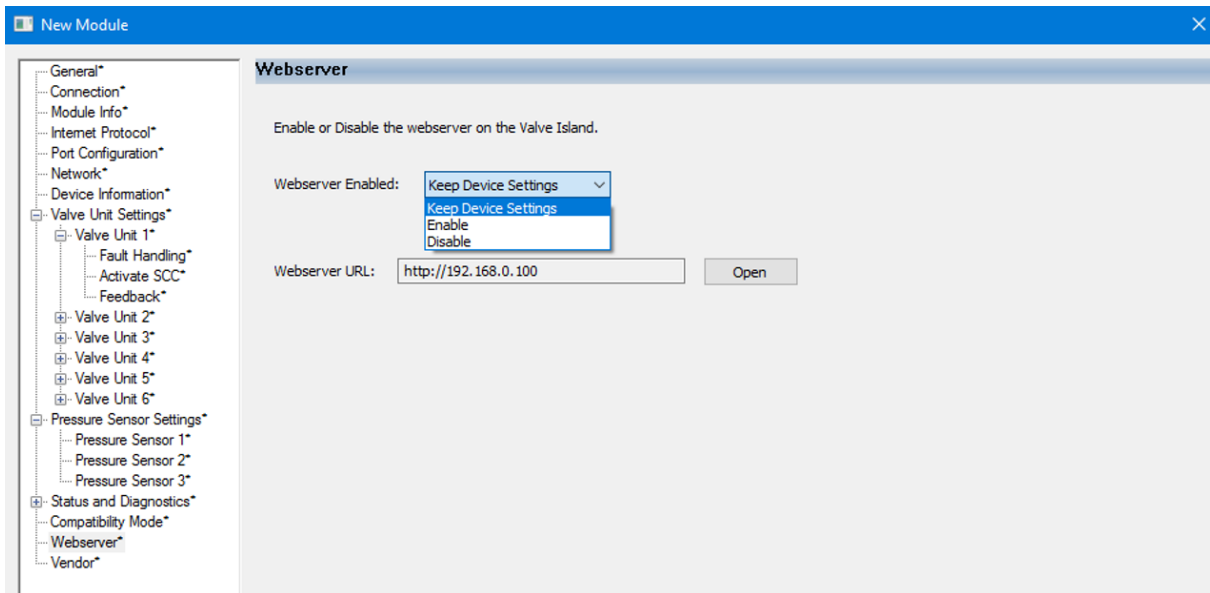

Finally, the accessibility of the web server can be configured. The web server can also be accessed directly from here.



To accept this setting, the valve island restarts at the time of the first connection to the controller.

Online information

Online information and writable values can only be changed on the device when the valve island is connected to the controller.

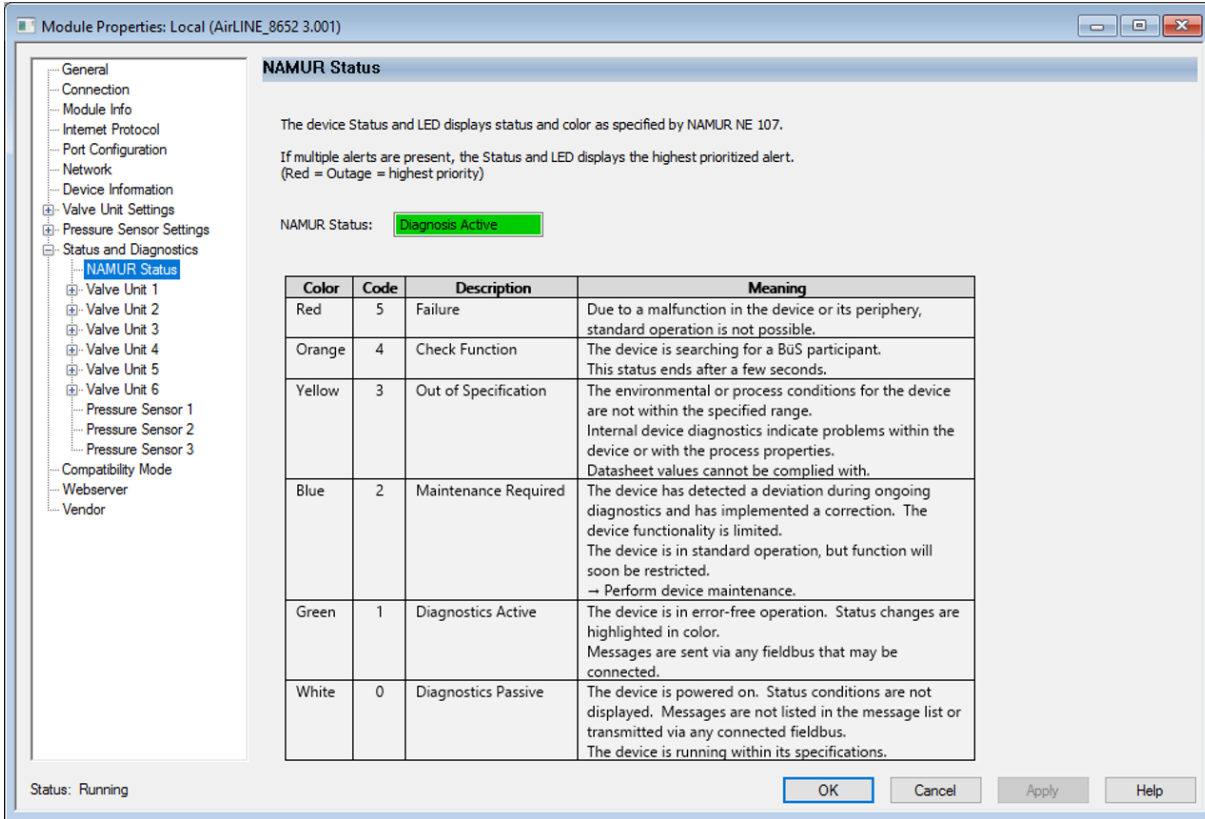

The current NAMUR status of the valve island is displayed and colour-coded.

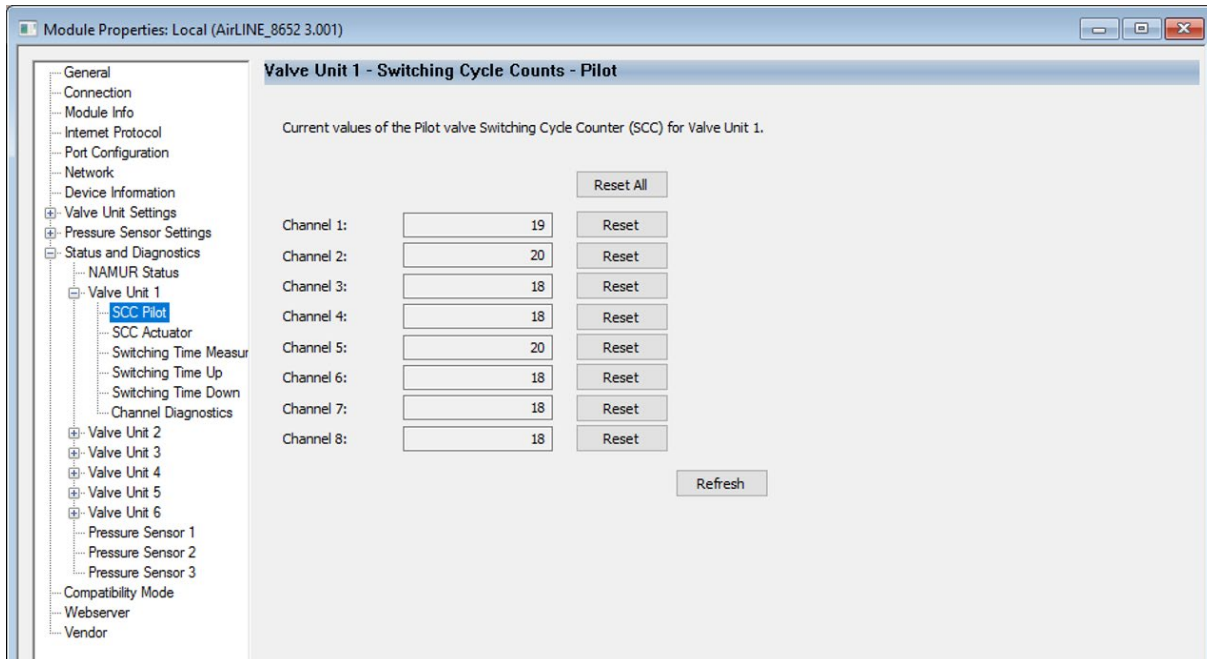

The current switching frequency of the pilot valves and actuators can be read and reset on a valve-by-valve or global basis when replacing valves.

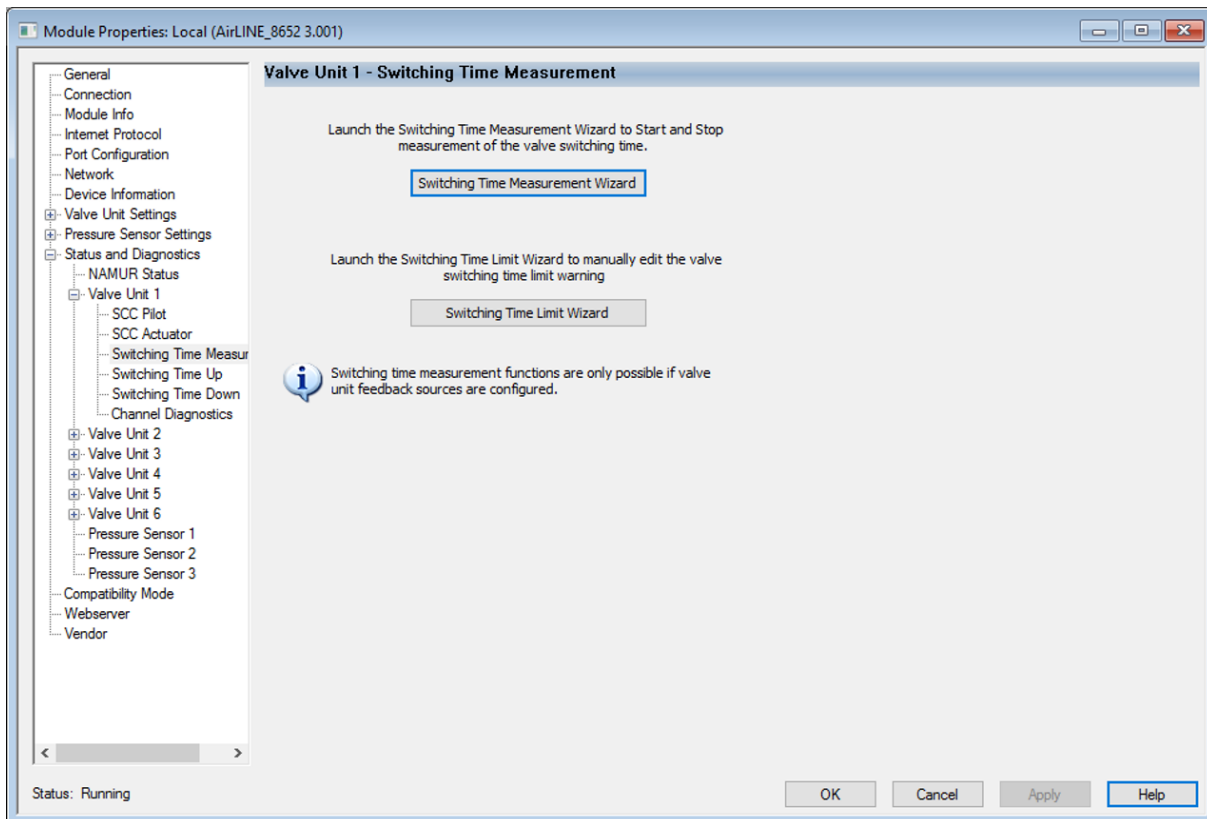

If position feedback indicators are present, the wizard can be started to initiate the switching time measurement or to enter the switching time limits; otherwise, the switches are greyed out. Detailed information about the wizards is displayed by clicking on the **Help** button.

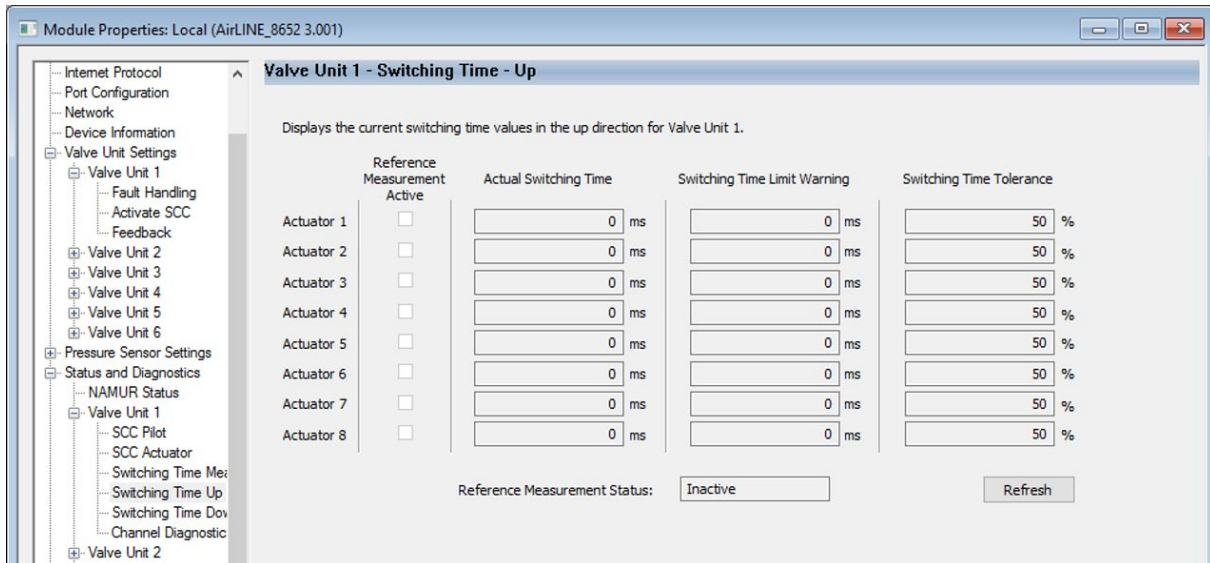

The current switching time and the switching time limits of each actuator can be displayed for the upper and lower position feedback indicators.

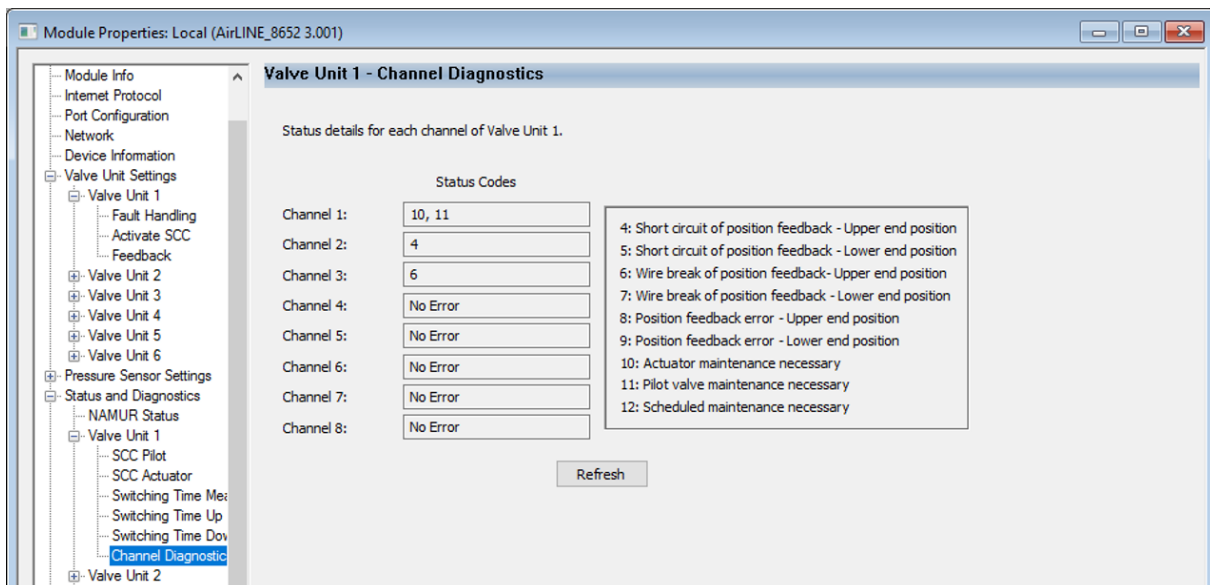

The diagnostics for each channel can be read, and the status code can be assigned to individual errors.

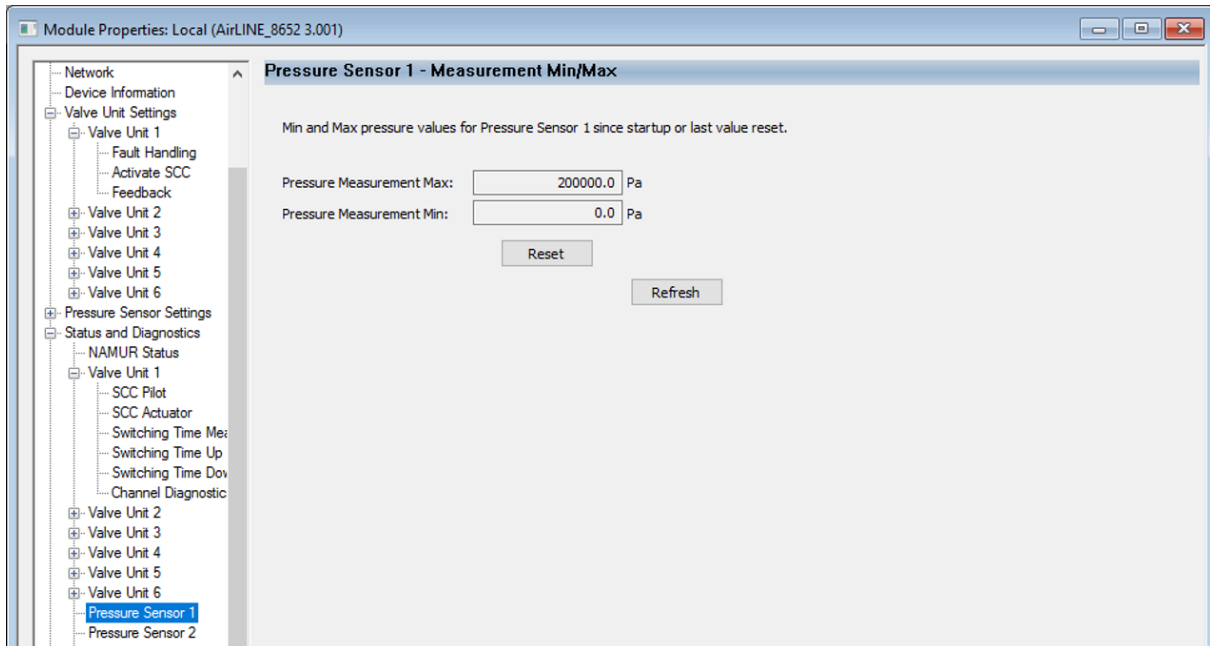

The measure minimum and maximum values of the pressure sensors are displayed in the stored pressure units and can be reset.



The revision of the connected valve island is shown here.

10.5.2 Commissioning with EDS file

→ Install EDS file. To do this, click on the **EDS Hardware Installation Tool** command in the **Tools** menu.

→ In the window that opens, click on **Register an EDS file.**

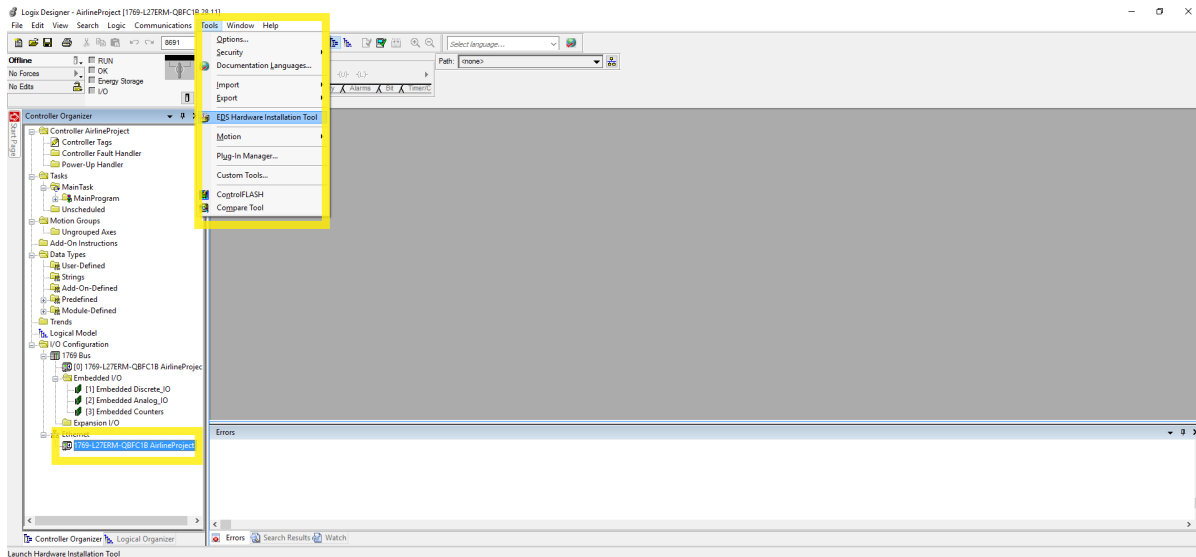

→ Right-click on **Ethernet** in the **Controller Organizer** window and select the **New Module** command. This opens the window **Select Module Type**.

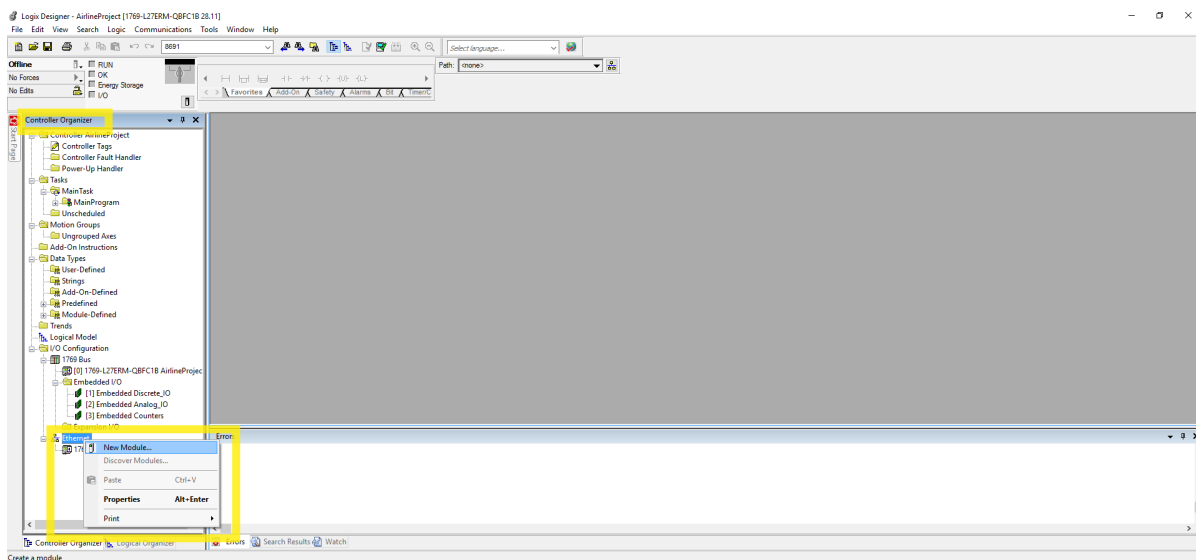

- Select the device in the **Catalogue** tab.
 - To simplify the search for the device:
 - select the filter "Buerkert Werke GmbH & Co. KG" or
 - enter the term "Airline" in the search field at the top left.
- Confirm with **Create**. This opens the **New Module** window.

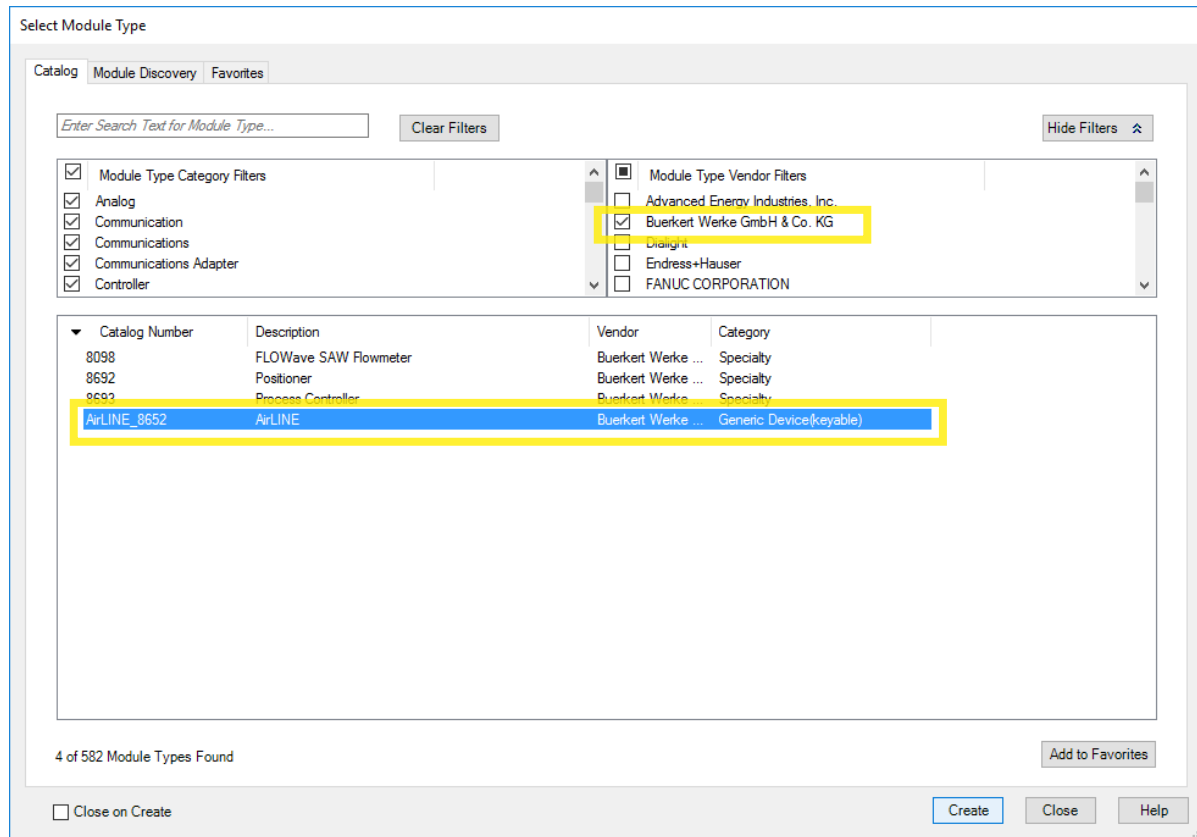

MAN 1000338074 EN Version: RL (released | freigegeben) printed: 23.05.2024

→ In the **New Module** window, choose the command **Change**. The **Module Definition** window opens.

→ Set the **Connections** in the **Module Definition** window:

- First the number of valve units used,
- then the number of pressure measurement modules * (if available).

The valve island shown on the right was configured in the following screenshots. This valve island has 3 valve units and 1 pressure measurement module.

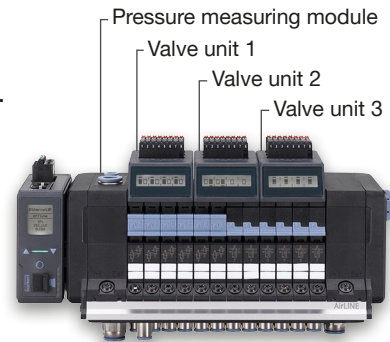

*) A connection module with an integrated pressure sensor is referred to as a "pressure measuring module".

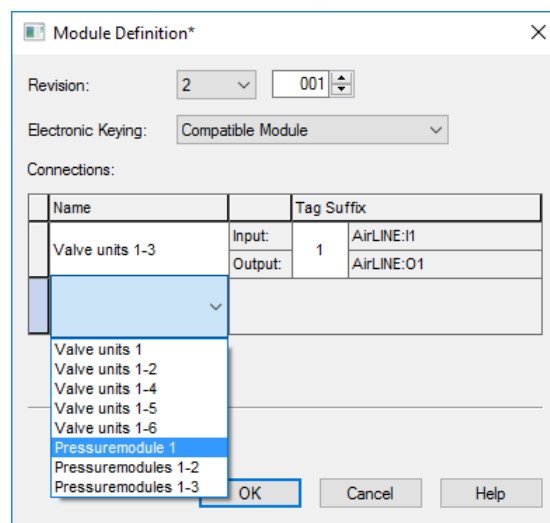
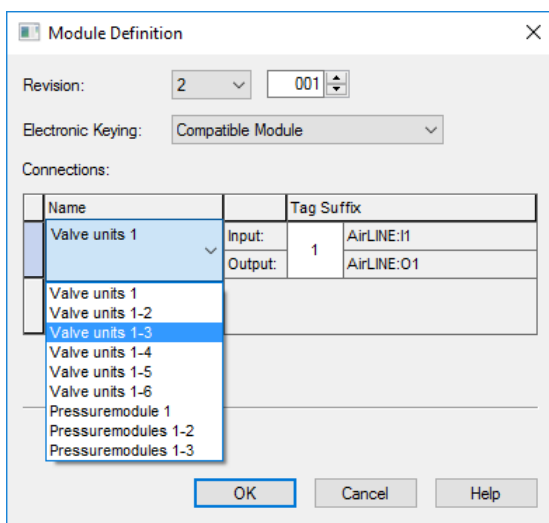

→ Confirm with **OK**.

→ The acyclic values of the valve island are displayed online in the **New Module** > **Parameters** window. The position feedback sensor source can also be set online here. The position feedback sensor source can also be set via the control program via acyclic access.

→ If the position feedback sensor source changes, restart the valve island.

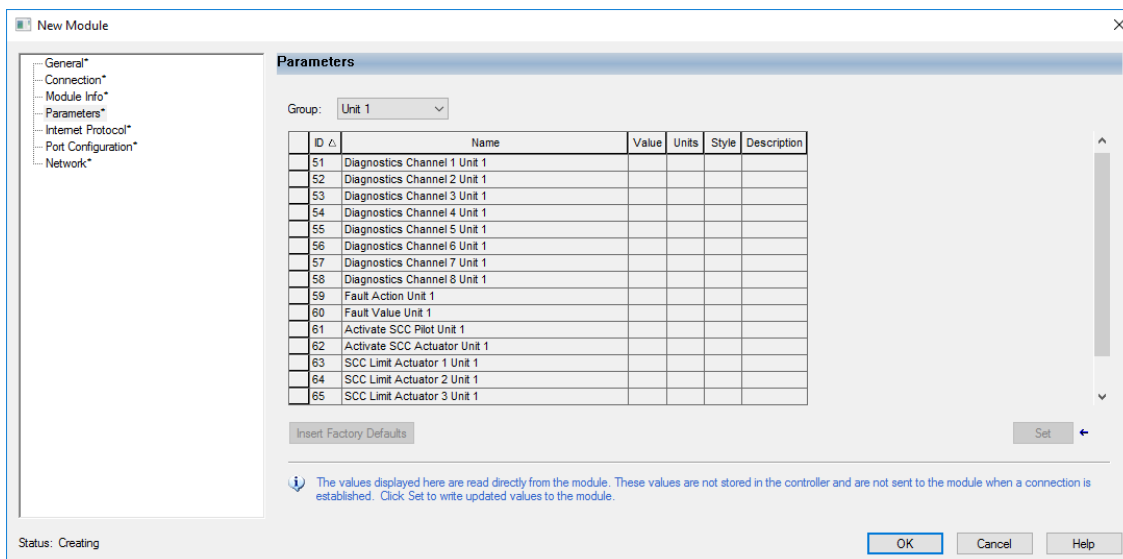

10.6 Bit-wise composition of the inputs and outputs

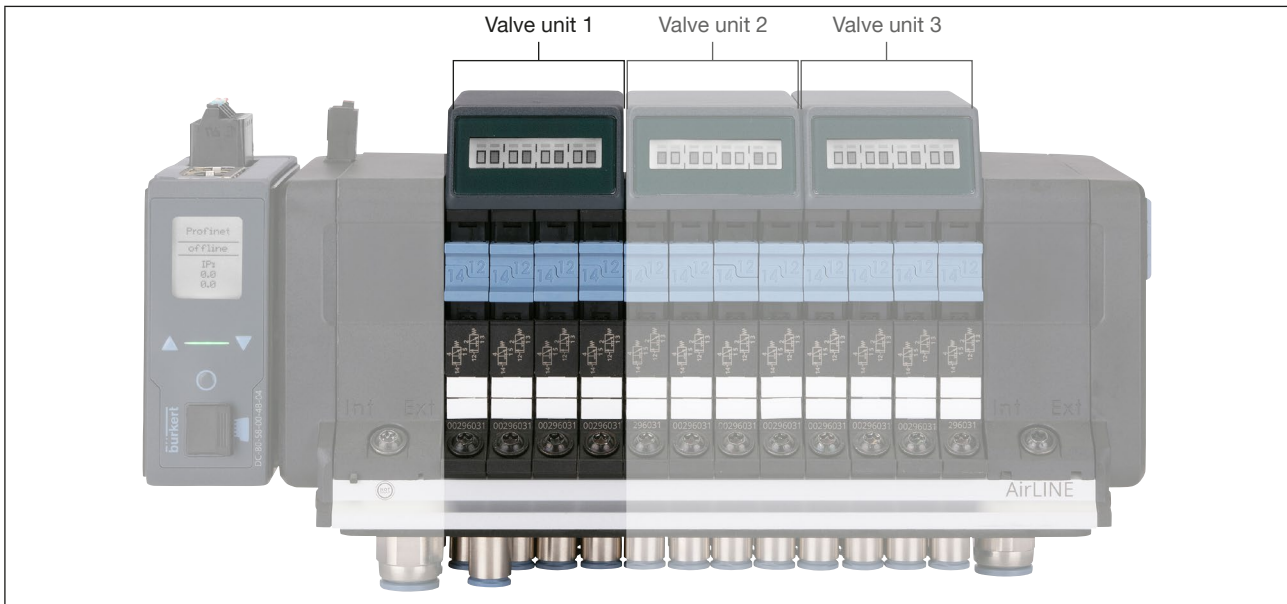

Figure 31: Valve units

The valve island is divided into valve units. A maximum of 8 valves (= 4 double valves!) are possible per unit. Depending on the configuration, each valve unit can have the following inputs and outputs (from the point of view of the PLC):

1 byte cyclic input	for feedback of upper end position via digital inputs, valve island or bÜS network
1 byte cyclic input	for feedback of the lower end position via digital inputs, valve island or bÜS network
1 byte cyclic output	for valves
1 byte cyclic output	for feedback upper end position via PLC
1 byte cyclic output	for feedback lower end position via PLC

The coding of the individual bits is always the same. Valve unit 1 is arranged on the left, valve unit 2 on the right, etc.

Further information can be found in the following chapters:

[“8.5 Electrical connection assignment”](#) on page 39

[“9.2 Pneumatic connection assignment”](#) on page 46

10.7 Advanced gateway functionalities



Information on:

Control mode (communication settings) and **Object Route Function** (access to other bÜS objects)

can be found at:

country.burkert.com → Type 8652 → Operating instructions → "Definition fieldbus"

11 CONFIGURATION WITH WEB SERVER

The valve island AirLINE Type 8652 has an integrated web server via which the device can be configured.

The web server can be used for the following protocols:

- PROFINET
- EtherNet/IP
- Modbus TCP

For access via web server, the device has a separate IP address.

11.1 Establishing a connection to the web server



Configuring multiple devices:

Because the devices have the same IP address upon delivery, there can only be 1 as yet unconfigured device in the network so that the device can be identified.

- ▶ Connect to the network and configure the devices individually in sequence.

→ Connect the PC to the device via a network cable.

→ Enter the IP address in the address line of the web browser.

With Ethernet/IP and Modbus TCP, the IP address of the device upon delivery is 192.168.0.100.

With PROFINET, the IP address is preset to 000.000.000.000. First, an IP address must be issued with a suitable tool, as otherwise there will be no connection to the web server. The IP address can be set with the display of the fieldbus gateway:

Parameters > Ind. Comm. > IP settings

If the IP address has been changed to an unknown value, the current IP address can be read in the Bürkert Communicator software or the display of the fieldbus gateway.

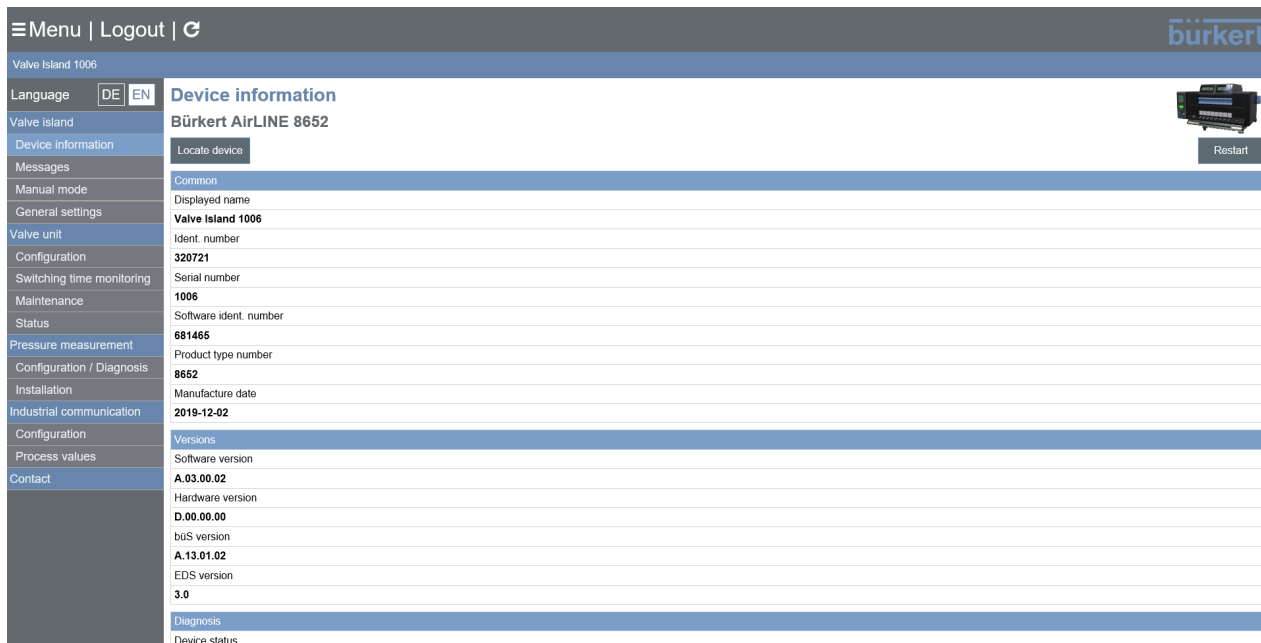

Figure 32: Web server view

11.2 Logging onto the web server

- On the home page, click on **Login** on the top left.
- Enter your user name and password: User name: **admin**
Password: **admin**
- Click on **Login**.

11.3 Passwords

CAUTION

Security risk due to standard passwords.

Unauthorised persons can log in to the web server and make changes to the system.

- ▶ Please change standard passwords.
- ▶ If the web server is not needed, disable access via Bürkert Communicator (see chapter [“16.10”](#) on page 90).

The following user names and passwords are active by default and are reactivated when the passwords are reset:

User name	admin	installer
Standard password	admin	admin

All user names have the same rights.

11.3.1 Change password

- Log in to the web server.
- Enter and confirm the new password in the menu **General settings**.

11.3.2 Reset passwords to factory settings

- Click on **Login**.
- On the bottom right of the login window, click on **Reset** passwords.

The device must be rebooted within 3 minutes so that the passwords can actually be reset. A restart can be triggered via the fieldbus gateway display, the Bürkert Communicator software or via a voltage reset.

11.4 Finding the device



In order to localise the currently selected device in the web server when using multiple devices, click the button **Locate device** in the “Device information” menu.

- ✓ The status LED of the selected fieldbus gateway flashes for a few seconds.

11.5 Disabling web server access with Bürkert Communicator

The web server is enabled upon delivery. Web server access can be disabled via the Bürkert Communicator software (see chapter [“16.10”](#) on page 90).

11.6 Information in the web server

11.6.1 Device information

Common	<ul style="list-style-type: none"> • Displayed name • Identification number of device • Device serial number • Software identification number • Product type number • Manufacture date
Versions	<ul style="list-style-type: none"> • Software version • Hardware version • bÜS version • EDS version
Diagnosis	Device status

11.6.2 Messages

Messages are shown in the order of type, time and message text.

11.7 Setting options in the web server

Configuration of the valve unit	<ul style="list-style-type: none"> • Valve configuration • Fault action • Fault state • Switching cycle counter • Position feedback sensor source • Display • Wire break detection active • Signal inversion
Switching time monitoring	For information, see chapter “21 Switch time monitoring function” on page 110
Maintenance	<ul style="list-style-type: none"> • Channel maintenance • Reset switching cycle counter of pneumatic slide valve • Reset switching cycle counter of actuators • Set the date for routine maintenance

Status of the valve unit	
Pressure measurement configuration	<ul style="list-style-type: none"> • Alarm limits • Pressure indicators on internal displays • Cyclical output of pressure value
Pressure measurement diagnostics	Display of the measured values: <ul style="list-style-type: none"> • Current pressure • Maximum pressure • Minimum pressure
Installation of pressure measurement	Enabling/disabling pressure sensors

11.8 Industrial communication of web server

Configuration	<ul style="list-style-type: none"> • Protocol • IP settings
Information	<ul style="list-style-type: none"> • Protocol • Communication status • Temporary IP address • MAC address
Indication of process values	Process name Process value

12 CONFIGURATION WITH FIELDBUS GATEWAY

If the fieldbus gateway is equipped with display and operating elements, settings can be made via the fieldbus gateway.

Basic variant

By pressing one of the two arrow keys, the display shows the valve status (see also chapter “14.3.2” on page 83)

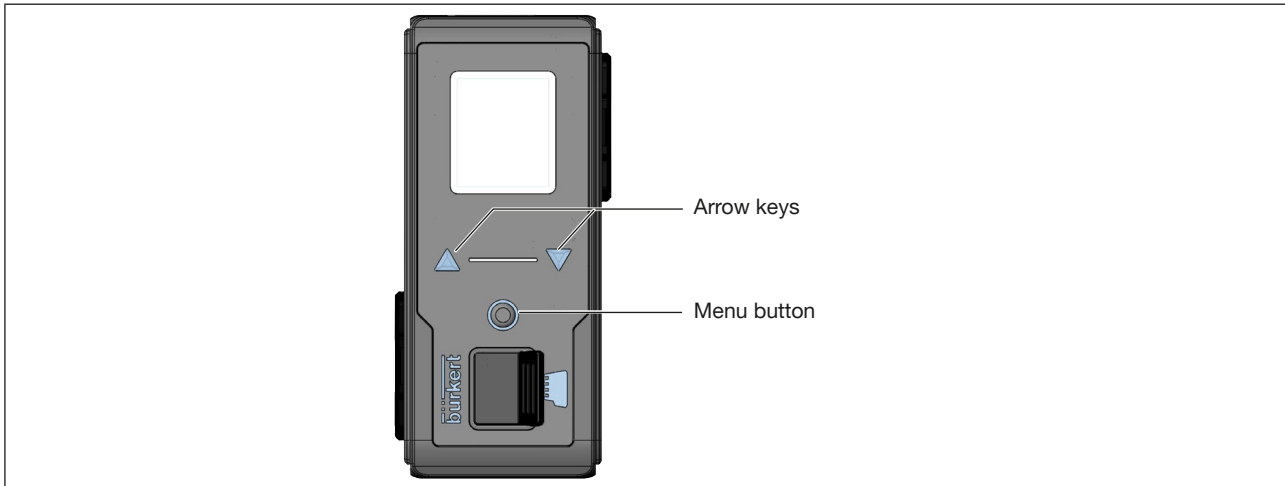

Figure 33: Overview of operating elements of fieldbus gateway ME43

12.1 Operating the fieldbus gateway



Element	Function
 Menu button	<ul style="list-style-type: none"> • Open main menu (double-click) • Confirm inputs
 Arrow keys	<ul style="list-style-type: none"> • Scroll in menu • Change values

Table 10: Function of the keys



With some menus, a restart is required in order to activate the new settings. The notification stating that a restart is required is displayed on the home screen.

→ Click on **Exit** to return to the home screen after changing the settings, and restart if necessary.

12.2 Selecting the protocol

With PROFIBUS DPV1, CC-Link and PROFINET S2, the protocol does not have to be selected. It is pre-set by the manufacturer.



For all other protocols:

→ Press the  menu button twice.

→ **Parameter** > **Ind. Comm.** > **Protocol**

→ Select and confirm desired protocol.

12.3 Enter PROFIBUS address or CC-Link address

- Press the  menu button twice.
- Select **Parameter** > **Ind. Comm.** > **Address**.
- Use  menu button to enable processing.
- Set, confirm and save the address with the arrow keys.



The **Address** menu is only available for PROFIBUS or CC-Link devices.

12.4 Converting compatibility mode

For information on the compatibility mode, see Chapter [“10.2”](#) on page 47 .

- Press the  menu button twice.
- Select **Parameter** > **Ind. Comm.** > **Comp. Mode**.
- Select **Specific** or one of the available compatibility modes and confirm.

12.5 Valve configuration

The valve configuration is performed if pneumatic valves are later used on valve slots occupied by blind valves. Or when valves of different types are alternated.



- Press the  menu button twice.
- Select **Parameter** > **AirLINE** > **Valve cnf** > **Module 1/2/...** > **Slot 1/2/...**
- Configure the valves accordingly.
- Use **Exit** to navigate to the highest menu level.

12.6 Configure pressure sensor(s)

- Press the  menu button twice.
- Select **Parameter** > **AirLINE** > **P.sens.conf** > **Left, Right** or **Middle**¹² > **Inactive** or **Active**.
- Use **Exit** to navigate to the highest menu level.

¹²⁾ Pressure sensor “Middle” is only available starting at configuration level ≥ 16 valve slots

12.7 Display: contrast, brightness, installation position, language

- Press the  menu button twice.
- Select **Parameter** > **Display**.
- Select the value to be changed.
- Use  menu button to enable processing.
- Set the desired value with the arrow keys.
- Confirm the value with the  menu button.
- Use **Exit** to navigate to the highest menu level.

12.8 Configuration provider

Specify whether the valve island will compile the configuration from other devices in the büS network (config clients) and saves it on the SD card.

This function is only possible if an SD card is present in the device (SD card, see chapter [“29 Accessories”](#) on page 136)

- Press the  menu button twice.
- Select **Parameter** > **CfgProvid.** > **Off** or **On**, confirm.

12.9 Error diagnostics

- Press the  menu button twice.
- Select **Diagnosis**, confirm.

The error type and error code are displayed.
See chapter [“27.5”](#) on page 131 for the description of error codes.

12.10 Restarting the valve island

Some settings require a reboot of the valve island.

- **Maintenance** > **Restart** > **Yes**

12.11 Factory reset

- **Maintenance** > **Fact. reset** > **Yes**

 The factory reset starts, and can take a few seconds.

12.12 Reset the switching cycle counters

The switching cycle counters can be reset for the complete valve island (all switching cycle counters of the pilot valves) or for each valve unit (modules).

- Press the  menu button twice.
- Select **Maintenance** > **Reset SCC**.
- Select **All SCC** or **Module 1/2/...** > **Yes**.

12.13 Replacing devices (config clients)

- Press the  menu button twice.
- Select **Maintenance** > **DevReplace**.
- Select serial number of original device.
- Select serial number of replacement device.
- **Do Replace**

13 MENU STRUCTURE FIELDBUS GATEWAY

ro = read only, rw = read / write

Parameters			
	Ind. Comm		
	IP Mode (with EtherNet/IP)		rw
		Feste IP	rw
		BOOTP	rw
		DHCP	rw
	IP setting (with Industrial Ethernet)		rw
		Address	rw
		Network	rw
		Gateway	rw
	Address (for PROFIBUS DPV1 and CC-Link)		
		Profibus address / CC-Link address	rw
	Protocol (preset at factory for PROFIBUS and CC-Link)		rw
		Profibus	
		CC-Link	
		EtherCAT	
		Profinet	
		EthIP	
		Modbus	
		CC-Link IE	
	Comp. mode		rw
		Specific	
		Comp. V1.0	
		Comp. V2.0	
		Comp. V3.0	
	BüS		
	Baud rate (can be set via PLC or Communicator)		ro
		1 Mbit/s	
		500 kbit/s	
		250 kbit/s	
		125 kbit/s	
		50 kbit/s	
	NodeID		rw
		Static	
		Used	
	Mode		rw
		Standalone	
		CANopen	
		büS	
	AirLINE		
	Valve conf		
	Module 1		
	Slot 1		
		Dummy valve	rw
		2x3/2 C	rw
		2x3/2 C SIA	rw
		2x3/2 D	rw
		5/2 H	rw
		5/2 H SIA	rw
		5/2 Z	rw
		5/2 Z	rw
		5/3 M	rw
		5/3 L	rw
		5/3 L SIA	rw

			5/3 N		rw
			Slot 2		
			see Slot 1		
			Slot 3		
			see Slot 1		
			Slot 4		
			see Slot 1		
		P.Sens.cnf			
		Left			
			Inactive		rw
			Active		rw
		Middle			
			Inactive		rw
			Active		rw
		Right			
			Inactive		rw
			Active		rw
		Display cnf			
			All disp.		rw
			Unit ...		rw
		Display			
			Contrast		rw
			Brightness		rw
		Mounting			
			Reverse		rw
			Normal		rw
			Auto		rw
		Language			
			German		rw
			English		rw
		CfgProvid.			
			Off		rw
			On		rw
		Diagnosis			
		Type code	If the type is "Error", the error code is displayed. Description of the error codes: Page 131		ro
		Maintenance			
		Restart			
			No		rw
			Yes		rw
		Fact. reset			
			No		rw
			Yes		rw
		Reset SCC			
			All SCC		rw
			Modul 1		rw
		ID number			ro
		Serial number			ro
		SW version			ro
		HW version			ro
		bÜS version			ro
		IComm-Ver.			ro
		DevReplace			
			Select S / N from orig. Ger.		rw
			X devices		rw
			Selection of S / N of replacement device		rw
			X devices		rw
			Do Replace		rw

14 FIELDBUS GATEWAY DISPLAY ELEMENTS

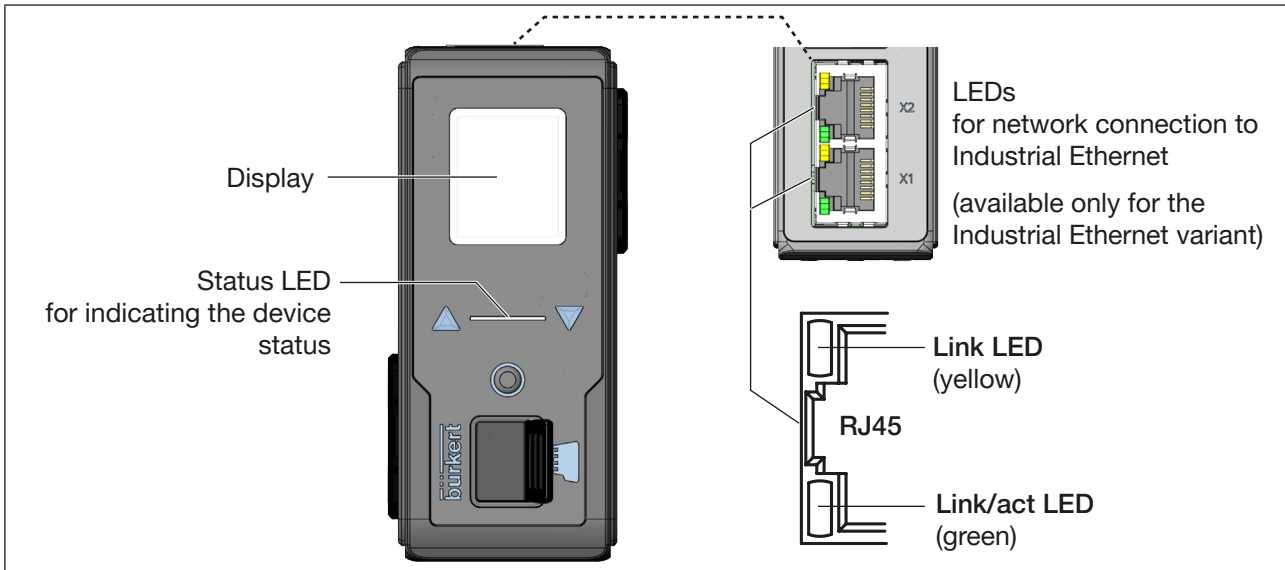

Figure 34: Overview of the display elements

14.1 LEDs for indicating the network connection to Industrial Ethernet

LED state		Description and cause of fault	Measure
Link LED (yellow)	active	Connection to network active	–
	Not active	No connection to the network available.	Check cable.
Link/act LED (green)	active	Rapid flashing: Connection to the higher protocol layer (PRO-FINET, EtherNet/IP or Modbus-TCP) is established. Data being transmitted Slow flashing, approx. 20 seconds after restart. No connection to the protocol layer available.	
	Not active	No connection to the network available.	Check cable.

Table 11: Description: LEDs for the network connection

14.2 LED for displaying the device status

The LED for displaying the device status changes colour and status similar to NAMUR NE 107.

If various alerts are present, the LED always shines in the colour of the highest prioritised alert (red = outage = highest priority).

Indicators in NAMUR operation mode:

Status LED in line with NE 107, issue 2006-06-12			
Colour	Colour code	Description	Meaning
red	5	Failure, error or fault	Due to a malfunction in the device or its periphery, standard operation is not possible.
Orange	4	Function control	The device is searching for a büS participant. This status ends after a few seconds.
Yellow	3	Outside the specification	The environment conditions or process conditions for the device are not within the specified range. Internal device diagnostics indicate problems within the device or with the process properties. Data sheet values cannot be complied with.
Blue	2	Maintenance required	The device has detected a deviation during ongoing diagnostics and has implemented a correction. Device functionality limited. The device is in standard operation, but function will soon be restricted. → Perform device maintenance.
green	1	Diagnostics active	Device is in error-free operation. Status changes are highlighted in colour. Messages are sent via any fieldbus that may be connected.
white	0	Diagnostics inactive	Device is switched on. Status conditions are not displayed. Messages are not listed in the message list or transmitted via any connected fieldbus. Device is running within its specifications.

Table 12: Indication of the device status in NAMUR operation mode



The LED flashes while settings are made with Bürkert Communicator.

14.3 Displays

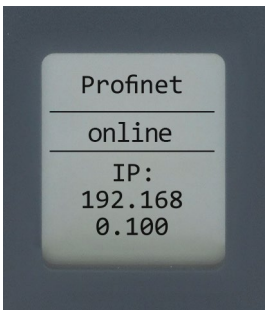
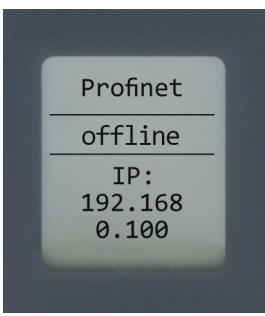
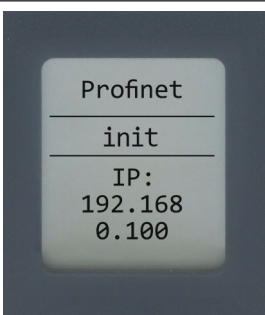
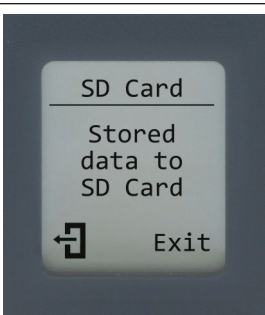
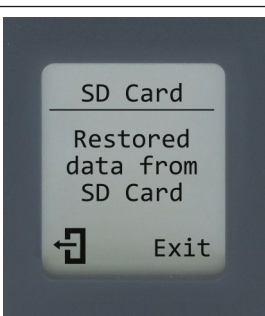
 <p>Profinet online IP: 192.168 0.100</p>	<p>Cyclic data traffic to the controller is active. The device is accessible via the IP address shown.</p>
 <p>Profinet offline IP: 192.168 0.100</p>	<p>Cyclic data traffic to the controller is inactive. The device is accessible via the IP address shown.</p>
 <p>Profinet init IP: 192.168 0.100</p>	<p>The device is initialising (temporary information) or settings still need to be set. The device is accessible via the IP address shown.</p>
 <p>SD Card Stored data to SD Card Exit</p>	<p>A new SD card has been recognised upon restarting. The SD card contains no data, or it contains data that are not compatible with the device. The existing device-specific values and user settings are written to the card.</p>
 <p>SD Card Restored data from SD Card Exit</p>	<p>A new SD card has been recognised upon restarting. The SD card contains data compatible with the device. The data on the SD card have been copied across from the device. The previous device-specific values and user settings have been overwritten.</p>

14.3.1 PROFINET S2 variant: display on the home screen

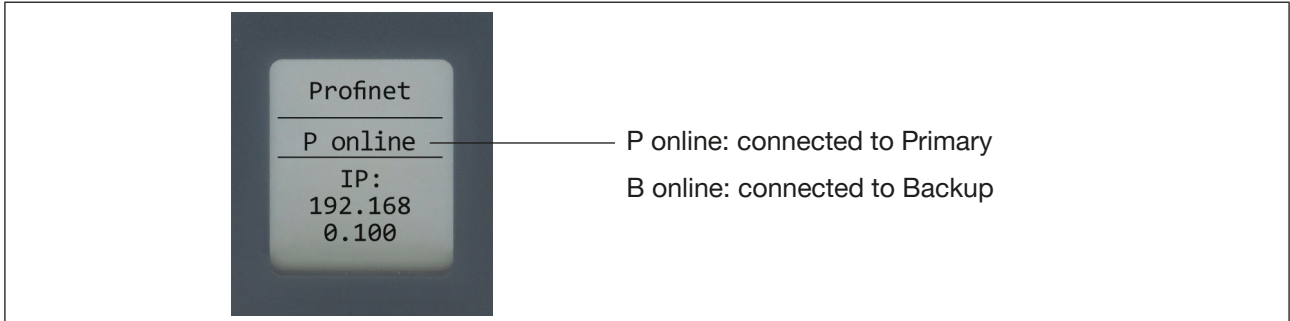

14.3.2 Basic variant: valve status display on fieldbus gateway

The valve status is indicated on the electronic module display. Since the Basic variant does not include an electronic module, the valve status can be shown on the fieldbus gateway display for this variant.

Pressing one of the two arrow keys on the fieldbus gateway switches the display between the home screen and the valve status display.

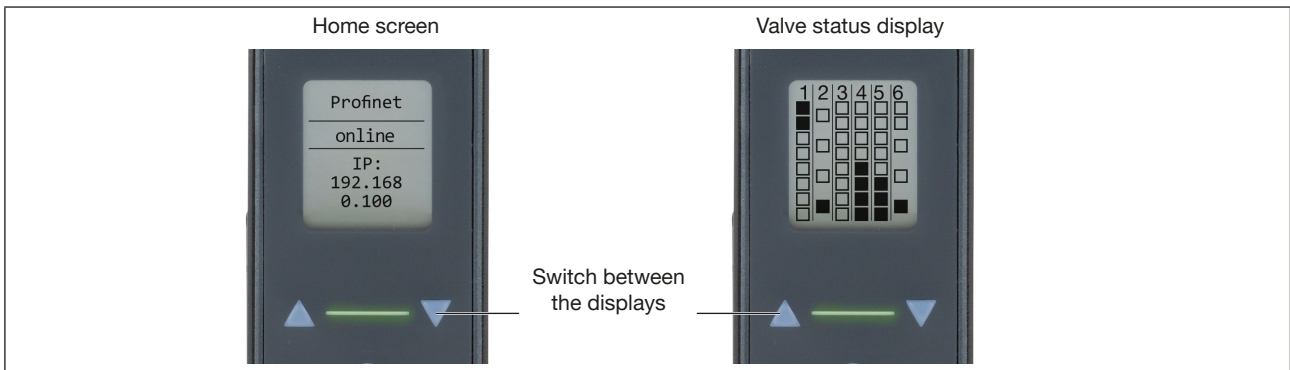

Figure 35: Basic variant, display options

Description of valve status display

	Display view with 6 valve units	
	Valve unit 1	4 double valves
	Valve unit 2	4 single valves
	Valve units 3–5	4 double valves each
Valve unit 6	1 double valve, 3 single valves	

Figure 36: Basic variant, description of valve status display

15 BÜRKERT COMMUNICATOR BASICS

The Bürkert Communicator software allows the comfortable configuration and monitoring of application-specific parameters.

! The software can be downloaded free of charge from the Bürkert homepage. In addition to the software, the USB-büS-interface, available as an accessory, is required (see chapter “29 Accessories”).

i The operating instructions for the basic functions of the software can be found on the Bürkert homepage: country.burkert.com → Type 8920

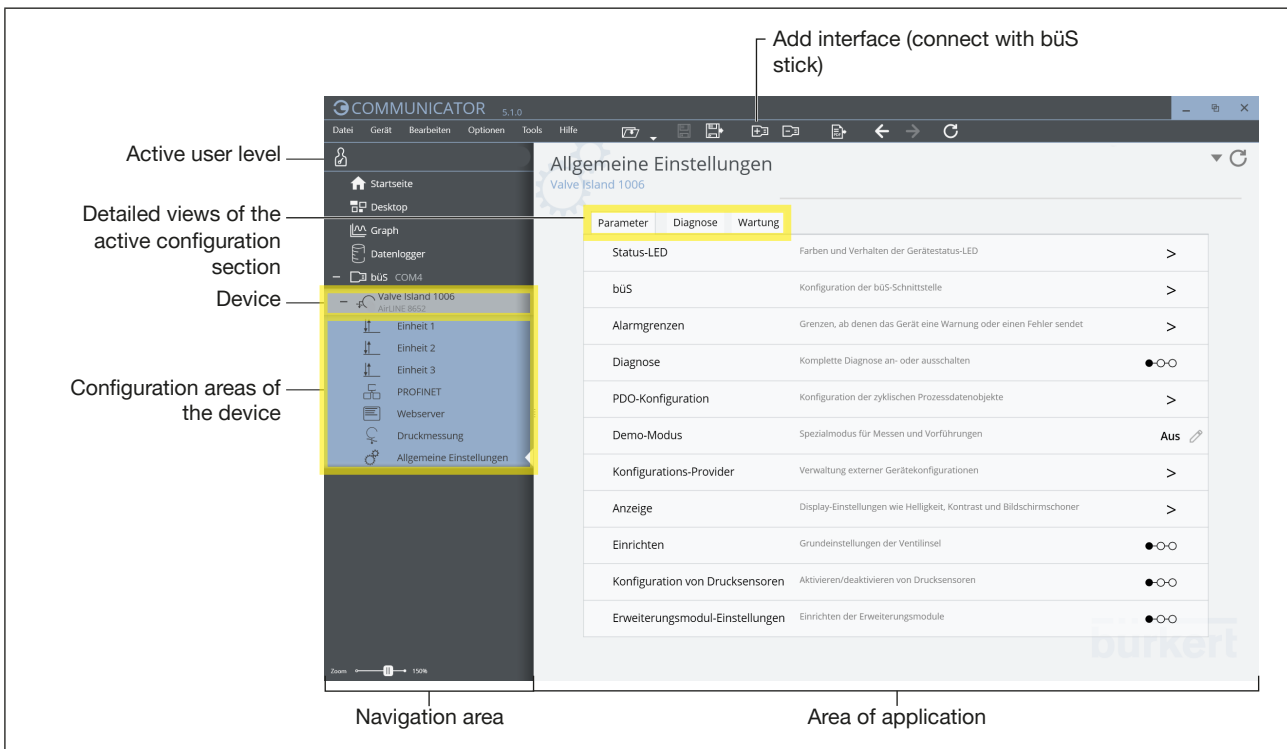

Figure 37: Example of a Bürkert Communicator user interface

When a device is connected to the Bürkert Communicator, it is displayed in the navigation section of the Communicator. Each device has configuration sections that are used to configure the device.

An overview of the menu structure can be found in chapter “17 Bürkert Communicator menu structure” on page 93.

Configuration section “Unit”

In the Communicator, a valve unit is referred to as a “unit” (1 valve unit = 1 electronic module with 4 valve slots).

The navigation section of the Communicator lists as many units as there are valve units in the valve island. The units are numbered consecutively, this corresponds to the sequence from left to right within the valve island.

MAN 1000338074 EN Version: AF Status: RL (released | freigegeben) printed: 23.05.2024

15.1 User levels

Bürkert Communicator is operated within user levels. There are 3 user levels, and each one has certain reading rights and writing rights.

The active user level is indicated by an icon on the upper left margin of the program window.



Icon	User level	Description	Standard password
	User	<ul style="list-style-type: none"> • Standard user • often only reading right, can change a few values • not all menus/values are displayed 	no password
	Advanced user	<ul style="list-style-type: none"> • can change certain values • can perform simple calibrations • not all menus/values are displayed 	5678
	Installer	<ul style="list-style-type: none"> • has all rights to operate the Communicator • all menus/values are displayed 	1946

Table 13: User levels in ascending order from top to bottom

15.1.1 Change user level

→ Click on the user levels icon on the upper left margin of the program window.

The **User password** window appears.

→ Enter the password for the desired user level in the input field.

The standard passwords are listed in [“Table 13”](#).

15.1.2 Changing user password

Required user level: “Installer”

Options > **Password manager ...**

→ If necessary, enter the installer password.

The **Change user passwords** window appears.

→ Enter desired password.

With the **Password manager**, passwords can also be reset to the standard settings.

15.1.3 Disabling user password

Required user level: “Installer”

Options > **Password manager ...**

→ If necessary, enter the installer password.

The **Change user password** window appears.

→ **Disable** the password at the desired user level.

User password	Active user level during program start
No user password disabled	User
“Advanced user” disabled	Advanced user
“Installer” disabled	Installer

15.2 Connecting the device to the Bürkert Communicator

- Install Bürkert Communicator on the PC.
- Set the terminating resistor (on the büS stick or external terminating resistor).
- Use the USB-büS-interface to establish the connection between the device and the PC.
- Start Bürkert Communicator.
- In the menu bar, click the icon  for **Add interface**.
- Select the **büS stick**.
- **Finish**
- ✔ The connection between the device and Bürkert Communicator is established, the device is displayed in the navigation area.



The LED for indicating the device status on the fieldbus gateway display flashes while settings are made with Bürkert Communicator.

16 CONFIGURATION WITH BÜRKERT COMMUNICATOR



If a menu is missing or cannot be set:

→ Check the version and the active user level (see chapter “15.1 User levels” on page 85). Some views / settings are only available with the appropriate rights.

16.1 Base valve island settings

Settings for the valve islands such as valve configuration, troubleshooting or position feedback sensor source are made in this menu via a wizard.

General settings > **Parameter** > **Setup**

✓ A wizard guides you through the base device settings.

16.2 Base Industrial Communicator settings

The protocol (**protocol name**) used is indicated in the configuration area of the Communicator. The protocol-specific settings on parameters, diagnostics and maintenance can be entered in this menu.

16.2.1 Starting the start-up wizard

The start-up wizard can perform protocol-specific settings and check them for accuracy. The start-up wizard is only available for Industrial Ethernet protocols.

(Protocol name) > **Parameter** > **(Protocol name) settings** > **IP parameter settings**

16.2.2 Change protocol

For devices with Industrial Ethernet, the protocol can be changed. If devices feature PROFIBUS, CC-Link or PROFINET S2, the fieldbus protocol has been preset at the factory and cannot be changed.

(Protocol name) > **Parameter** > **Change protocol**

→ In the drop-down menu on the right, select the protocol.

→ Restart the device.

16.2.3 Configuring the fieldbus gateway

The device description file must first be loaded in the corresponding projection tool (e.g. TIA portal, RSLogix) for the fieldbus configuration. The corresponding protocol-specific settings can then be made in the configuration area **(protocol name)**.



The description of the gateway configuration can be found in the fieldbus gateway Type ME43 operating instructions at: www.burkert.com

If additional bus devices are connected to the valve island and are to be connected to a controller through them, the valve island can also be configured as a gateway.

Note! This generates a new description file, and functions such as PROFINET alarms or generally acyclic data of the valve island are no longer accessible to the controller. That is why this function is only conditionally recommended.

16.2.4 Enter PROFIBUS address

PROFIBUS > Parameter > PROFIBUS Settings > PROFIBUS Address

→ Enter address. Valid addresses: 0–126 (factory setting value: 3)
If an address outside the valid range has been set, the device will issue an error message.

16.2.5 Entering CC-Link address

CC-Link > Parameter > CC-Link Settings > CC-Link Address

→ Enter address. Valid addresses: 1–64 (factory setting value: 64)

16.2.6 Converting compatibility mode

For information on compatibility mode, see chapter “10.2” on page 47.

(Protocol Name) > Parameter > PLC Connection Compatibility

→ Use the wizard in the drop-down menu to select the required version of the start-up data for the device.

16.2.7 Read current IP address

If the IP address has been changed to an unknown value, the current IP address can be read in Bürkert Communicator.

(Protocol name) > Parameter > (Protocol name) settings

16.2.8 Settings of the Industrial Ethernet protocols

(Protocol name) > Parameter > Protocol settings

Protocol	EtherCAT	PROFINET / PROFINET S2	EtherNet/IP	Modbus TCP	CC-Link IE Field Basic
Fixed IP address	–	X	X	X	X
Network interface	–	X	X	X	X
Standard gateway	–	X	X	X	X
Temporary IP address	–	X	X	–	–
DNS-compatible name (no special characters _ () / \ * are allowed in the name)	–	X	–	–	–

Factory settings:

Protocol	EtherCAT	PROFINET	EtherNet/IP	Modbus TCP
Default IP address	–	000.000.0.000	192.168.0.100	192.168.0.100
Default name	–	AirLINE-8652	–	–

16.3 Base settings CANopen/büS

If devices feature CANopen/büS communication, the “CANopen” bus operation mode has been preset at the factory.

16.3.1 Switching over bus operation mode

Bus operation mode can be switched over to “büS” using Bürkert Communicator.

General settings > **Parameter** > **büS** > **Advanced** > **Bus mode**

→ Select the bus operation mode in the drop-down menu on the right.

16.4 Active pressure sensor

When the connection modules of the valve island are equipped with integrated pressure sensors, the corresponding pressure sensors on the device are enabled by the factory and the diagnostic function **Pressure measurement** is displayed in the Communicator.

If connection modules with pressure sensors are subsequently integrated into the valve island, these pressure sensors must be enabled via the Bürkert Communicator.

During activation, make sure that only the sensors that are actually present in the valve island are enabled. If sensors that are not present are enabled, the device displays an error message.

General settings > **Parameter** > **Configuration of pressure sensors**

16.5 Disable or enable module supply monitoring

The supply voltage monitoring is enabled on the device by the factory. If the supply voltage for the valve block, valve units or individual valves is interrupted, an error message is sent to the controller.

The monitoring of the supply voltage can be disabled in the Bürkert Communicator if required.

General settings > **Parameter** > **Configuration of module supply monitoring**

16.6 Change “error” report status

With the **Configuration of error status** function, reports with the “error” status can be converted to a lower status in order to influence the effects of an error on the system.

General settings > **Parameter** > **Configuration of error status**

Troubleshooting

If the “error status” option is enabled, the valve assume the status that has been set in the **Unit X** > **Fault handling** menu.

When the “bueS pre-operational” option is enabled, no more cyclical data is sent to the büS network. This is detected by consumers in the büS network, which then generate an error.

16.7 Reset device to factory settings

Select **General settings** > **Maintenance** > **Reset device** > **Reset to factory settings**

16.8 Restart device

Some settings require a restart of the valve island.

Maintenance > **Reset device** > **Restart**

16.9 Switch time monitoring of actuators

Monitoring the switching time duration of process valves. For further information, see chapter [“21 Switch time monitoring function”](#) on page 110.

Unit X > **Actuator switching time** > **Measurement**

✔ A wizard starts measuring the actuator run time.

16.10 Disabling access to web server

The valve island has an integrated web server via which the device can be configured. The web server is enabled upon delivery. Web server access can be disabled via the Bürkert Communicator software.

Web server > **Parameter** > **Activate web server**

See also chapter [“11”](#) on page 70 .

16.11 Using Extension Modules (EM)



This function is available for backward compatibility purposes and does not contain any of the new functions.

The description of how to connect other devices with the controller can be found in the fieldbus gateway Type ME43 operating instructions at: www.burkert.com.

Extension modules are installed on a valve island with a fieldbus connection. This means that additional valve islands can be controlled via this valve island without a fieldbus connection.



1 extension module corresponds to 1 valve unit (4 valves and 1 electronic module).

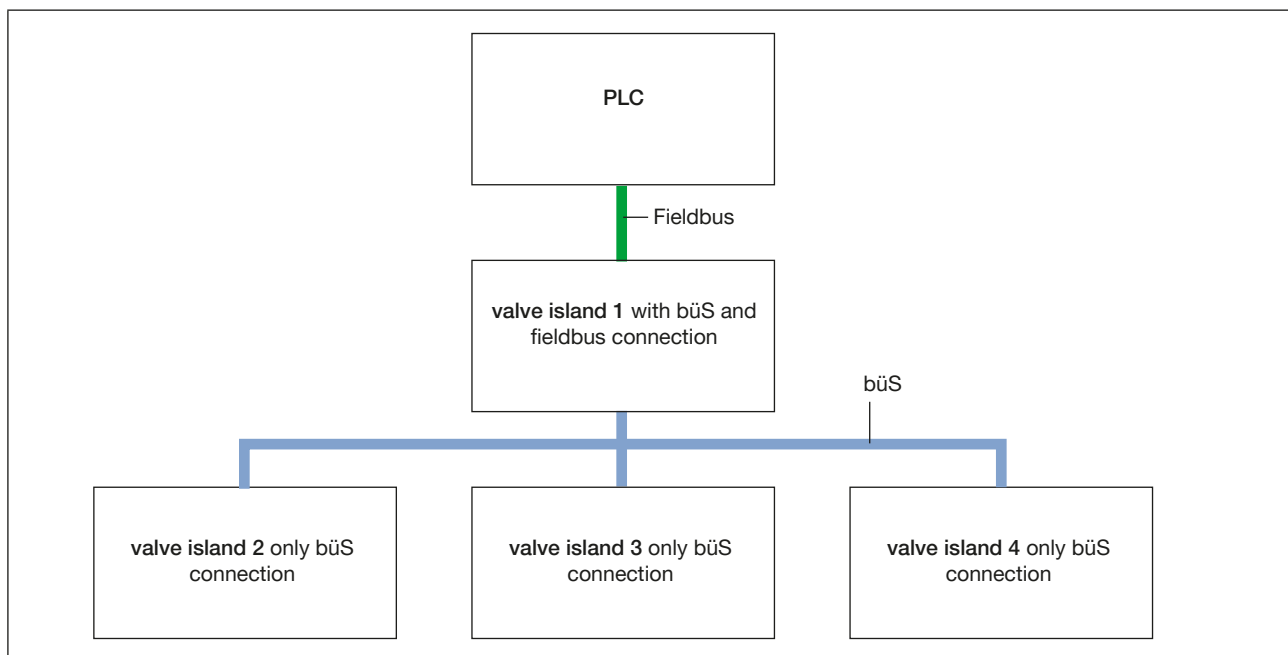

Figure 38: Schematic structure of a bus system with extension modules

16.11.1 Configuring the fieldbus

If the valve island is operated with extension modules, the corresponding start-up files must be used. These start-up files do not contain any acyclic objects. The configuration of valve islands with extension modules must be done via the Bürkert Communicator.

The start-up files required by the respective project planning software, such as EDS files, GSD and GSDML files, are available on the Internet.



Download the start-up files from: country.burkert.com → Type 8652 → Software → Device Description Files.zip



There are 2 variants of the start-up files available for download for each protocol. The variants differ in whether the valve island is operated with extension modules or not.

Start-up files for valve islands with extension modules have the designation "EM" in the file name.

Please refer to the documentation of your project design software for instructions regarding the installation of the start-up files.

16.11.2 Configuring the valve island with extension modules

General settings > Parameter > Extension module settings

A wizard will guide you through the settings.

→ Finish

✔ A restart is triggered. There are 9 extension modules available.

16.11.3 Configuring the bÜS network

→ Select **bÜS** in the navigation area, activate the detailed view of the **Network Configuration**.

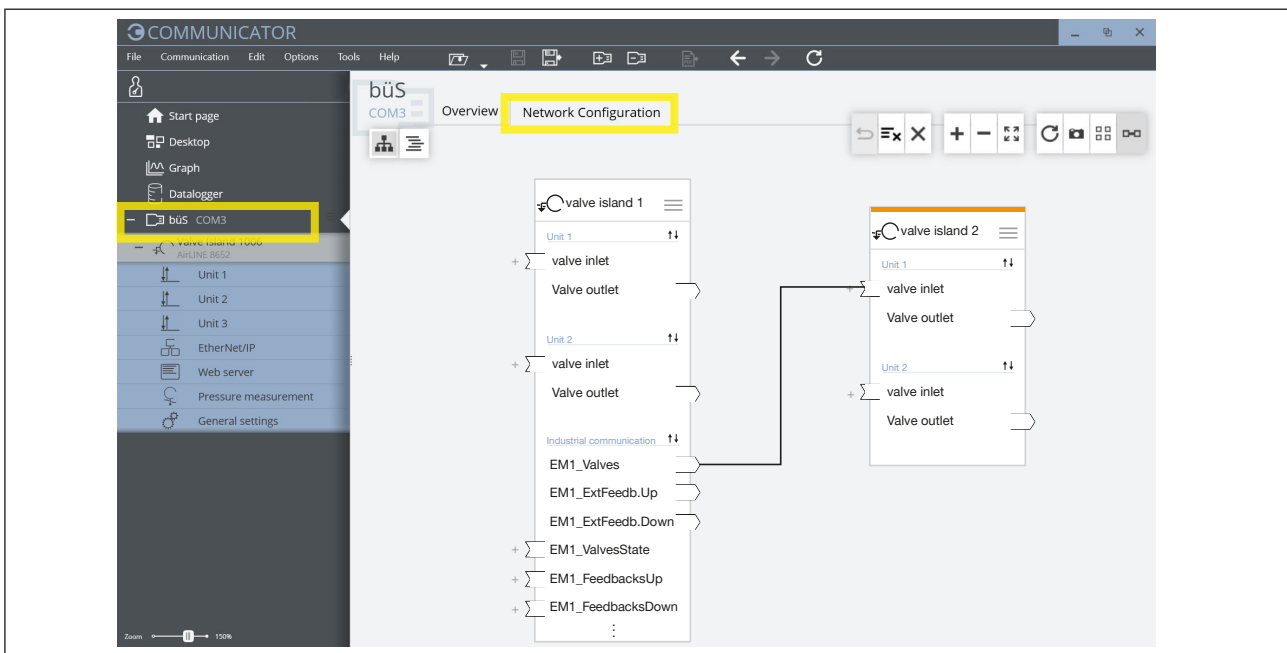

Figure 39: Configuring the bÜS network in the "Network configuration" detail view

The network can be configured in 2 ways:

1. Per Drag-and-drop

→ Connect the inputs and output via drag-and-drop.

(Compatible connection points are highlighted in blue. Dashed connections do not yet represent an active connection between devices.)

2. Via selection list

→ Click on the **+** in front of the respective entrance.

Possible connections are offered as a selection list.

→ Click on the desired connection. The connection is created automatically.

With both types:

→ Once all connections have been made, select **Apply changes**.

All configured devices are re-started.

The bÜS network is configured.

17 BÜRKERT COMMUNICATOR MENU STRUCTURE



Bürkert Communicator is operated within user levels. There are 3 user levels, and each one has certain reading rights and writing rights.

See also chapter “User levels” on page 85 .



The number of menus depends on the configuration of the device. It is therefore possible that not all menus are displayed in your application.

ro = read only, rw = read/write

Configuration section “Unit”					
Parameter					
	Valve configuration		rw	rw	rw
	Fault handling		rw	rw	rw
	Diagnostics		rw	rw	rw
	Position feedback sensor		rw	rw	rw
	Actuator switching time				
		Reference measurement	rw	rw	rw
		Settings	rw	rw	rw
	Display		rw	ro	ro
Diagnosics					
	Channel maintenance		ro	ro	ro
	Channel fault		ro	ro	ro
Maintenance					
	Actuator		rw	rw	rw
	Pilot valve		rw	rw	rw
	Routine maintenance		rw	rw	rw

Configuration area “(protocol name)”					
Parameter					
	(Protocol name) settings				
	(PROFIBUS DPV1)	PROFIBUS address	rw	ro	ro
		Set baud rate	rw	ro	ro
		Current baud rate	(visible, if baud rate “Auto” is read-only)		
		Advanced settings			
		Internal cycle time	rw	ro	ro
		Control mode settings	rw	-	-
		Firmware update protocol	rw	-	-
	(CC-Link)	Address	rw	ro	ro
		Transmission speed	rw	ro	ro
		Number of stations	ro	-	-
		Number of cycles	ro	-	-
		CC-Link version	ro	-	-
		Advanced settings			
		Internal cycle time	rw	ro	ro
		Control mode settings	rw	-	-
		Firmware update protocol	rw	-	-
	(EtherCAT)	Start startup wizard	rw	-	-
		Station alias	rw	ro	ro
		MAC address	ro	ro	ro
		Advanced settings			
		Internal cycle time	rw	ro	ro

MAN 1000338074 EN Version: AF Status: RL (released | freigegeben) printed: 23.05.2024



Configuration area "(protocol name)"					
		Control mode settings	rw	-	-
		Firmware update protocol	rw	-	-
(PROFINET)	Start startup wizard		rw	-	-
	IP parameter settings		rw	-	-
	DNS compatible name		rw	ro	ro
	Static IP address		rw	ro	ro
	Network mask		rw	ro	ro
	Default gateway		rw	ro	ro
	Temporary IP address		rw	ro	ro
	MAC address		ro	ro	ro
	Advanced settings				
		Alarm settings	rw	ro	ro
		Internal cycle time	rw	ro	ro
		Control mode settings	rw	-	-
		Firmware update protocol	rw	-	-
(EtherNet/IP)	IP parameter settings		rw	-	-
	IP settings		rw	ro	ro
	Static IP address		rw	ro	ro
	Network mask		rw	ro	ro
	Default gateway		rw	ro	ro
	Temporary IP address		rw	ro	ro
	MAC address		ro	ro	ro
	Advanced settings				
		Internal cycle time	rw	ro	ro
		Control mode settings	rw	-	-
		Protocol firmware update	rw	-	-
(Modbus TCP)	Start startup wizard		rw	-	-
	IP parameter settings				
	Static IP address		rw	ro	ro
	Network mask		rw	ro	ro
	Default gateway		rw	ro	ro
	MAC address		ro	ro	ro
	Advanced settings				
		Internal cycle time	rw	ro	ro
		Timeout communication	rw	ro	ro
		Control mode settings	rw	-	-
		Firmware update protocol	rw	-	-
(CC-Link IE Field Basic)	Start startup wizard		rw	-	-
	IP parameter settings				
	Static IP address		rw	ro	ro
	Network mask		rw	ro	ro
	Default gateway		rw	ro	ro
	MAC address		ro	ro	ro
	Advanced settings				
		Internal cycle time	rw	ro	ro
		Control mode settings	rw	-	-
		Firmware update protocol	rw	-	-
Gateway configuration					
	Download a gateway configuration file		rw	-	-
	Create a gateway configuration		rw	-	-
	Reset gateway configuration to factory settings				
Hide process values					
	Edit hide objects		rw	-	-
	Reset hide objects		rw	-	-
Change protocol			rw	-	-

Configuration area "(protocol name)"					
	Protocol		rw	-	-
	PLC connection compatibility				
	Select:		rw	ro	ro
	Start-up file version				
Diagnostics					
	Protocol		ro	ro	ro
	Communication status		ro	ro	ro
	Control mode settings		ro	ro	ro
	Connections to PLC		ro	ro	ro
	Used internal cycle time		ro	ro	ro
	Advanced				
	Last status code		ro	-	-
Maintenance					
	Version numbers				
	Stack Name		ro	ro	ro
	Stack Version		ro	ro	ro
	Stack Build		ro	ro	ro
	Stack Revision		ro	ro	ro
	Stack Date		ro	ro	ro
	ICom Version		ro	ro	ro
	Hardware reset		rw	-	-

"Web server" configuration area					
Parameter					
	Activate web server		ro	-	-

"Pressure measurement" configuration area					
Parameter					
	Pressure sensor (left / middle / right)				
	Alarm limits				
		Maximum pressure	ro	ro	ro
		Error high	rw	ro	ro
		Error low	rw	ro	ro
		Warning high	rw	ro	ro
		Warning low	rw	ro	ro
		Hysteresis	rw	ro	ro
		Enter fault state	rw	ro	ro
	Presentation				
		Display number	rw	rw	rw
		Unit	rw	rw	rw
	Cyclic output active		rw	ro	ro
Diagnostics					
	Pressure sensor (left / middle / right)				
	Status of pressure infeed				
	Pressure		ro	ro	ro
	Maximum pressure		ro	ro	ro
	Minimum pressure		ro	ro	ro
	Reset min/max values		rw	rw	ro

MAN 1000338074 EN Version: AF Status: RL (released | freigegeben) printed: 23.05.2024

Configuration section "General settings"					
Parameter					
Status LED					
	Mode		rw	ro	ro
	Colour (menu only appears when the "Fixed colour" operation mode is activated)		rw	ro	ro
büS					
	Displayed name		rw	rw	ro
	Location		rw	ro	ro
	Description		rw	ro	ro
	Advanced				
		Unique device name	rw	ro	ro
		Baud rate	rw	ro	ro
		Fixed CANopen address	rw	ro	ro
		CANopen address	ro	ro	ro
		Bus mode	rw	ro	ro
	Menu only appears when "CANopen" is selected as the bus operation mode.	CANopen status	rw	ro	ro
	Menu only appears when "büS" is selected as the bus operation mode.	Show errors from büS partners	rw	ro	ro
		Deallocation delay	rw	ro	ro
Alarm limits					
	Supply voltage				
		Error low	ro	ro	ro
		Error high	ro	ro	ro
		Hysteresis	ro	ro	ro
	Device temperature				
		Error low	ro	ro	ro
		Error high	ro	ro	ro
		Hysteresis	ro	ro	ro
		Warning battery voltage low	ro	ro	ro
Diagnostics			rw	ro	ro
PDO Configuration			rw	rw	rw
Demo mode			rw	-	-
Configuration provider					
	Status		rw	ro	ro
	Remove device configurations		rw	ro	ro
	Reconfiguration of all devices		rw	ro	ro
	Ignore offline clients		rw	ro	ro
Display					
	Brightness		rw	rw	ro
	Contrast		rw	rw	ro
	Fieldbus gateway installation position		rw	rw	ro
	Screensaver				
		Delay	rw	rw	ro
		Brightness	rw	rw	ro
	Language (German / English)		rw	rw	ro
	Reinitialisation		rw	-	-
Setup			rw	-	-
Configuration of valve unit displays			rw	ro	-
	Unit ...		rw	-	-
Configuration of pressure sensors			rw		
Configuration of module supply monitoring			rw		
Configuration of error status			rw		
Configuration of external DI modules			rw		
Configuration of extension module			rw	-	-

Configuration section "General settings"					
Diagnostics					
Device status					
	Operating duration		ro	ro	ro
	Operating period since last boot		ro	ro	ro
	Device temperature		ro	ro	ro
	Supply voltage		ro	ro	ro
	Voltage drops		ro	ro	ro
	Min./Max. values		ro	ro	ro
		Min. temperature	ro	ro	ro
		Max. temperature	ro	ro	ro
		Min. supply voltage	ro	ro	ro
		Max. supply voltage	ro	ro	ro
	Device boot counter		ro	ro	ro
	Transferable memory status		ro	ro	ro
	Current system time		ro	ro	ro
	Battery voltage		ro	ro	ro
bÜS status					
	Receive errors		ro	ro	ro
	Receive errors max.		ro	ro	ro
	Transmit errors		ro	ro	ro
	Transmit errors max.		ro	ro	ro
	Reset error counter		rw	ro	ro
	CANopen status		ro	ro	ro
Logbook					
Configuration provider					
	Status		ro	ro	ro
	Managed clients		ro	ro	ro
	- Thereof offline configurations		rw	rw	rw
	- Thereof ordered reconfigurations		rw	rw	rw
	Reconfigured devices		rw	rw	ro
	Loaded device configurations		rw	rw	ro
	Missing devices		rw	rw	ro
	Faulty configuration load processes		rw	rw	ro
	Faulty reconfigurations		rw	rw	ro
	Managed clients		ro	ro	ro
Maintenance					
Device information					
	Ident. number		ro	ro	ro
	Serial number		ro	ro	ro
	Firmware ident. number		ro	ro	ro
	Firmware version		ro	ro	ro
	bÜS version		ro	ro	ro
	Hardware version		ro	ro	ro
	Product type		ro	ro	ro
	Manufacture date		ro	ro	ro
	EDS version		ro	ro	ro
	Device driver				
		Driver version	ro	ro	ro
		Firmware group	ro	ro	ro
		Origin	ro	ro	ro
	Hardware index				
		General	ro	ro	ro
		Display modules	ro	ro	ro
		DI modules	ro	ro	ro
Reset device					
	Restart		rw	ro	ro
	Reset to factory settings		rw	ro	ro

18 START-UP

18.1 Safety instructions



WARNING

Risk of injury due to improper operation.

Improper operation may result in injuries as well as damage to the device and the surrounding area.

- ▶ Before start-up, ensure that the operating personnel are aware of and have completely understood the contents of the operating instructions.
- ▶ Observe the safety instructions and information on intended use.
- ▶ Only adequately trained specialists are allowed to put the device into operation.

NOTE

Internal short circuit between the auxiliary pilot air and the pilot pressure.

To avoid an internal short circuit, the seals of the connection modules must be positioned the same (external or internal supply of auxiliary pilot air). Mixing the external or internal supply is not permitted.

- ▶ Before start-up, check whether all seals on the connection modules are positioned in the same way (external or internal, see “Figure 29” on page 45).

18.2 Commissioning via manual override

Manual override is ideal for starting up the device and system. The manual override works without voltage being applied to the valve island and allows manual valve switching.

Depending on the circuit function (CF) of the valves, the manual overrides are labelled differently:

CF C, CF Z, CF H (for CF H only 1 manual override):

Labelling	Effect of the switched manual override
12	Supply channel 1 connected to working port 2
14	Supply channel 1 connected to working port 4

CFD:

Labelling	Effect of the switched manual override
10 (12)	Connection between supply channel 1 and working port 2 interrupted
10 (14)	Connection between supply channel 1 and working port 4 interrupted

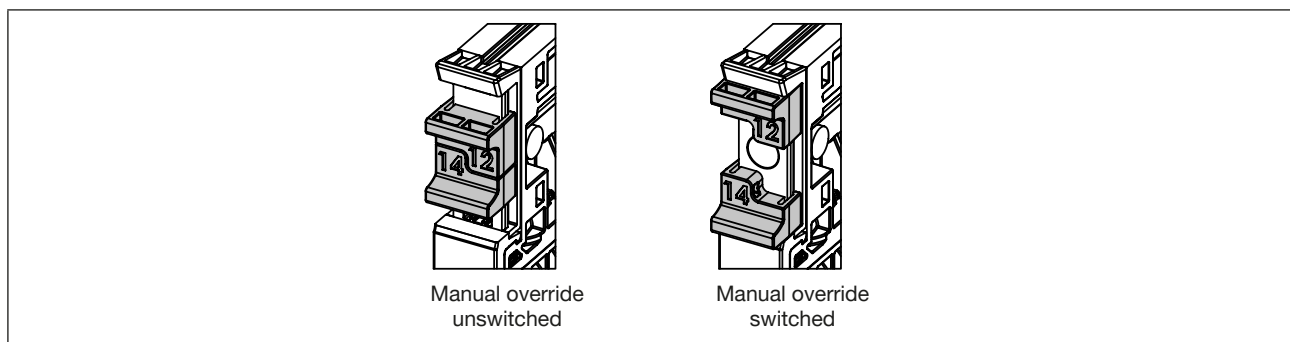

Figure 40: Manual override of the valves

The standard manual override is spring return and latching.

Spring return:

If the sliding mechanism is moved to a first resistor, the manual override returns to the unswitched state after release.

Latching:

If the resistor is exceeded, the manual override stops in the switched state after release. Slide mechanism must be pushed back manually over the locking point to reset the manual override to the unswitched state

18.2.1 Additional element “Lock Manual Override”

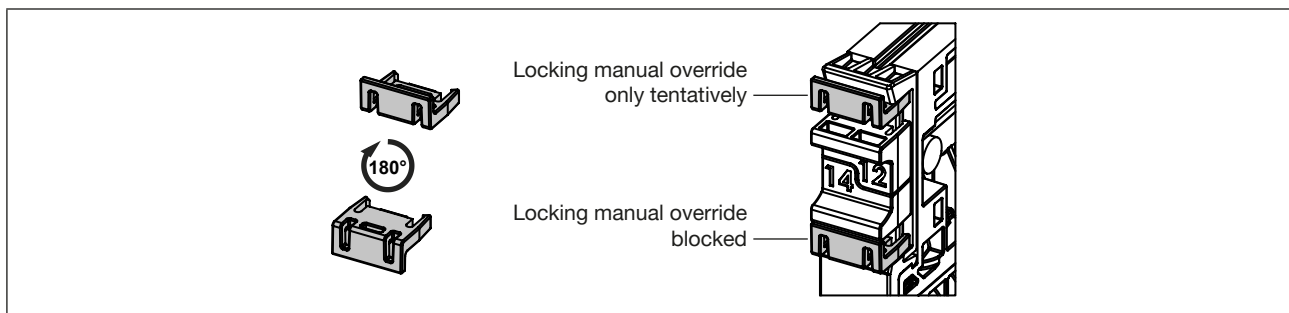

Figure 41: Additional element “MO locking”

The additional element "Lock Manual Override" enables manual override to be restricted.

Depending on the rotational position (rotated 0° or 180°) of the clipped-in additional element, manual override is only tentative or locked.

The additional element is available as an accessory (see [“Other accessories”](#) on page 138).

18.3 Identification of the valve positions

Device markers in MultiCard format are included in the scope of delivery of the valve island:

Inscription label ESG 5/10 MC NE WS

The device markers are fixed to a sprue and can be printed in this form using standardised industrial printers (e.g. from Weidmüller). After printing, the device markers can be removed from the sprue and clipped onto the valve.

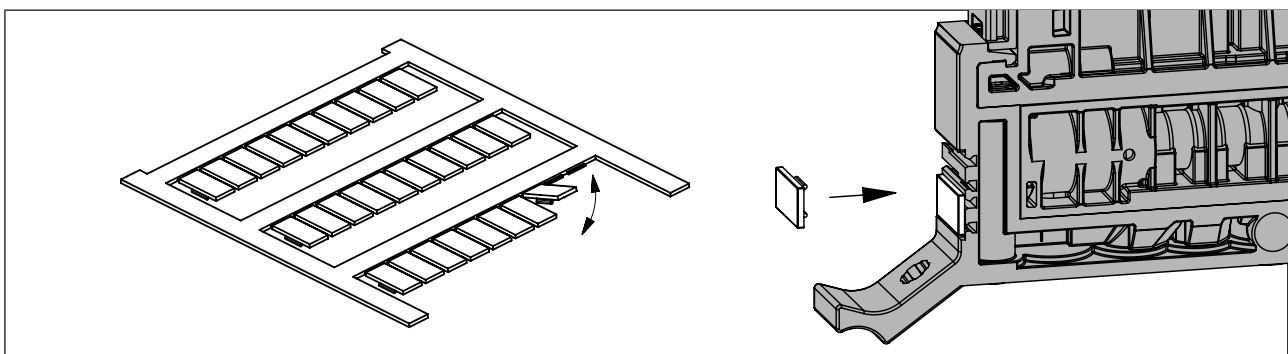

Figure 42: Labelling of the valve positions with device markers in MultiCard format: After printing, the device markers can be removed from the sprue and clipped onto the valve.

19 DISPLAY ELECTRONIC MODULE

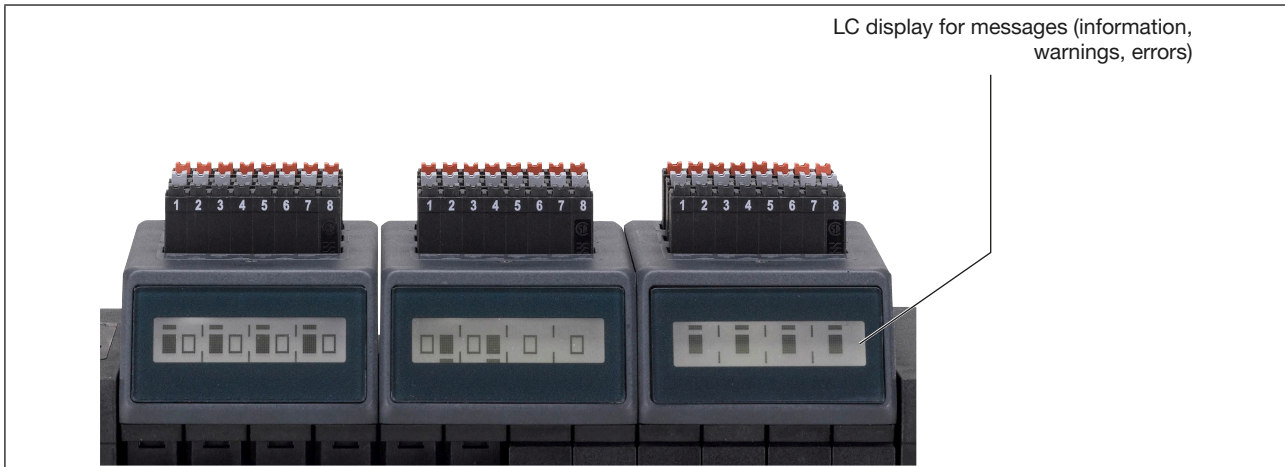

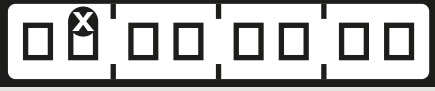
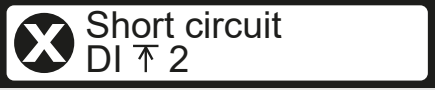
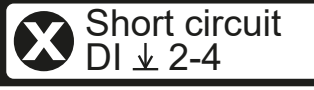
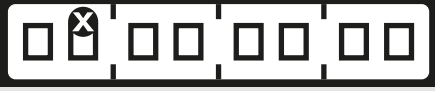

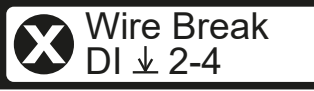
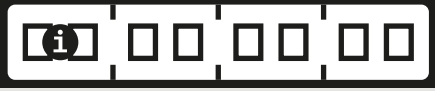

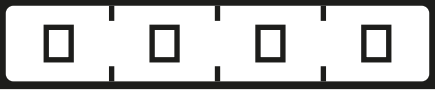

Figure 43: Display elements on the electronic module

The electronic modules are equipped with an LC display for status display. The switch position and possible error states of the outputs are shown graphically on the display. Depending on the configuration of the module, additional information can be displayed, e.g.

- Position of the actuator that is assigned to the output,

Any messages (information, warnings, errors) appear as text on the LC display. The text message is displayed alternating cyclically with the graphical display of the channel status.

	Display view with 4 valve positions (e.g. 5/2-way valves)
	Display view with 4 valve positions (Double valves, e.g. 2x3 / 2-way valves)
	Mixed display view (double and single valves)
	Valve 1 actuated
	Valve 1 actuated, Feedback: "Upper end position reached"
	Valve 1 actuated, Feedback: "Lower end position reached"
	Valve 1 + 2 each have 1 valve slot Valve 3 + 4 each have 1 empty slot (blind valve)

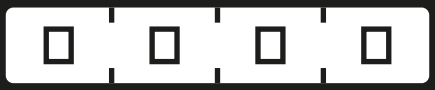
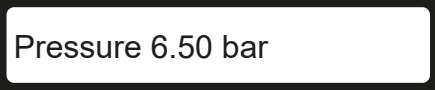
<p>Message 1/message 2 in alternation:</p>  <p>Message 1</p>  <p>Message 2</p>	<p><i>Short circuit on input 2 of the upper position feedback sensor unit</i></p>	<p>Example of further possible messages:</p>  <p><i>Short circuit on inputs 2–4 of the lower position feedback sensor unit</i></p>
<p>Message 1/message 2 in alternation:</p>  <p>Message 1</p>  <p>Message 2</p>	<p><i>Wire break on input 2 of the upper position feedback sensor unit</i></p>	<p>Example of further possible messages:</p>  <p><i>Wire break on inputs 2–4 of the lower position feedback sensor unit</i></p>
<p>Message 1/message 2 in alternation:</p>  <p>Message 1</p>  <p>Message 2</p>	<p><i>Maintenance limit for pilot valve 1 reached</i></p>	<p>Example of further possible messages:</p> <p>Act. SCC limit Ch. 1</p> <p><i>Maintenance limit for actuator 1 reached</i></p>
<p>Message 1/message 2 in alternation:</p>  <p>Message 1</p>  <p>Message 2</p>	<p><i>EVS has been implemented for this valve unit. Logic, display and diagnostics continue to operate unaffected and remain available.</i></p>	
<p>Message 1/message 2 in alternation:</p>  <p>Message 1</p>  <p>Message 2</p>	<p><i>If connection modules are equipped with an integrated pressure sensor, the current medium pressure can be indicated on the display (can be activated via the web server or the Bürkert Communicator software).</i></p>	

MAN 1000338074 EN Version: AF Status: RL (released | freigegeben) printed: 23.05.2024

Message 1/message 2 in alternation:

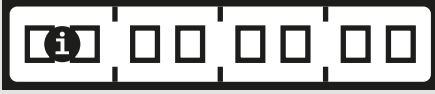

Message 1



Message 2

The switching time of actuator 1, lower end position, has been exceeded (also see [“21 Switch time monitoring function” on page 110](#)).

20 COMBINE VALVE ISLAND WITH EXTERNAL DI MODULES

If the number of digital inputs (DIs) on the valve island is insufficient or the valve island does not have DIs, external DI modules can be added as position feedback sensor sources.

External DI modules can, for example, be B. 8DI modules of type ME44 or 16DI modules of type ME64.

The start-up files of the valve island already contain the settings of the external DI modules.



Download the start-up [files from: country.burkert.com](https://files.country.burkert.com) → Type 8652 → Software → Device Description Files.zip

Steps required:

1. Assign position feedback sensor source in the automation software (see “20.1”).
2. Assign position feedback sensor source in Bürkert Communicator (see “20.2”).
3. Carry out network configuration in the Bürkert Communicator (see “20.3”).
4. Set the display of error messages in the Bürkert Communicator (see “20.4”).

These settings must be made separately for each valve unit.

Alternatively: required steps via a wizard:

If the configuration is identical for each valve unit, it is recommended to use a wizard in the Bürkert Communicator. The procedure is described in Chapter “20.5 Configure external DI modules using a wizard”.

20.1 Assign position feedback sensor source in the automation software

CAUTION

With PROFIBUS and PROFINET, the settings in the automation software overwrite the settings in the Bürkert Communicator.

- ▶ Make sure that the settings are identical in both programs.



For the external DI modules, the position feedback sensor source is always "büS" or "büS network".

Information on start-up with automation software can be found in Chapter “10 Integration into the control environment” on page 47 .

20.2 Assign position feedback sensor source in Bürkert Communicator

The position feedback sensor source must be assigned to each valve unit separately.

In the valve island configuration area :

User level: Installer

→ Choose **unit**.

→ Select the source for the upper end position and the lower end position under **Parameter** > **Position feedback sensor**.

20.3 Network configuration in the Bürkert Communicator

This chapter describes the configuration of valve island / DI module combinations using 3 examples.

Where is the network configuration done?

User level: Installer

→ Click in the configuration area on the büS interface .

→ Select the "Network configuration" tab in the work area.

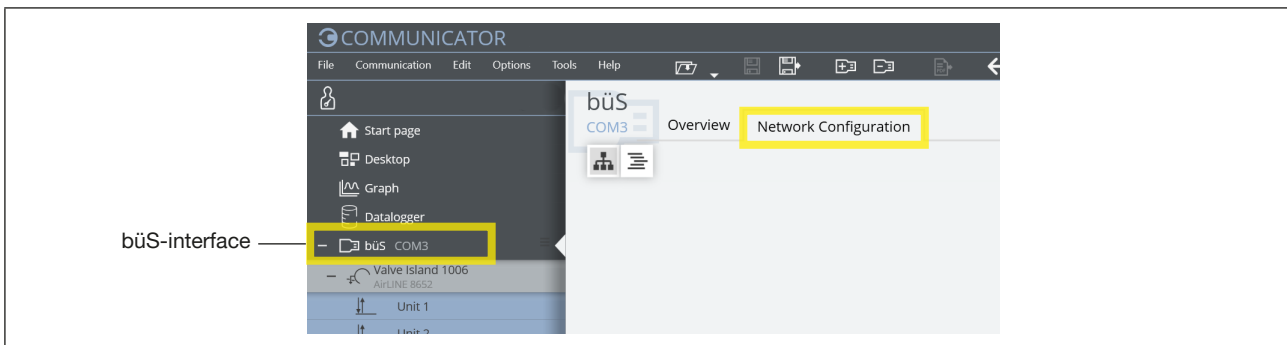

20.3.1 Example 1: Valve island with 6 valve units and 6 internal DI modules in combination with 8DI modules ME44

A maximum of 2 DI modules (each with 8 DIs) are possible per valve unit. In the case of a valve island with 6 valve units and 6 internal DI modules, a maximum of 6 external 8DI modules can be used.

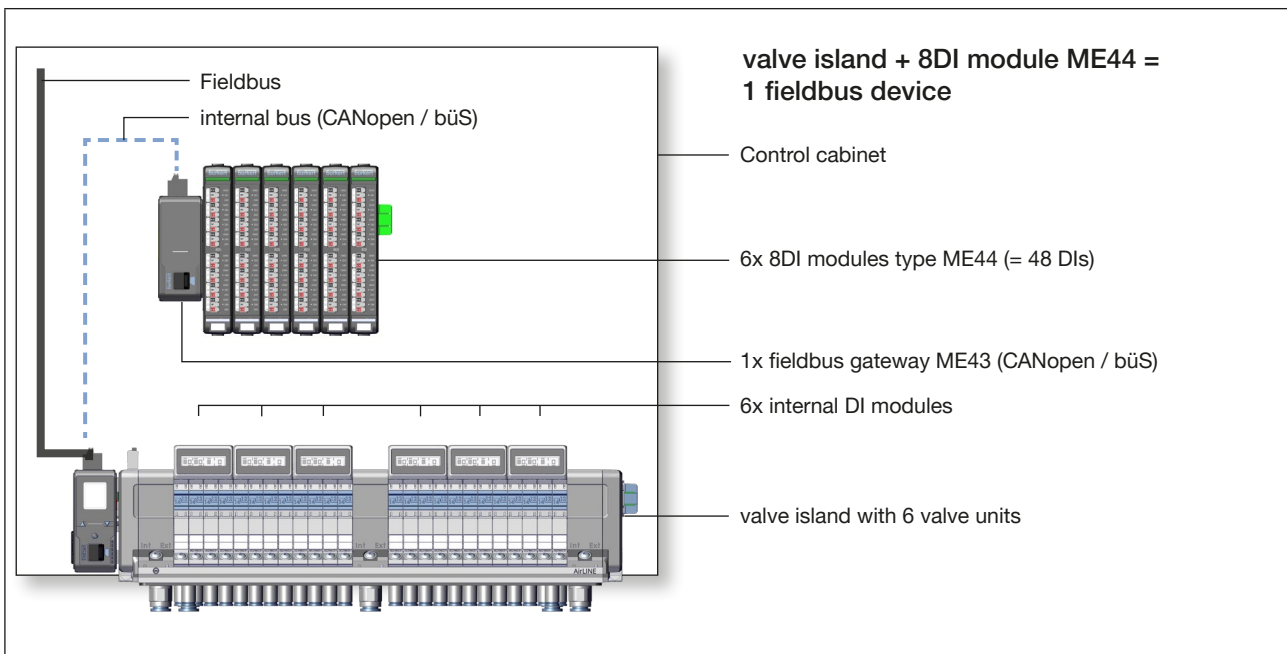

Network configuration of example 1 in the Communicator:

In the example, the following position feedback sensor sources are assigned:

Upper end position "External DI module (büS)"

lower end position "Integrated DI module"

! The assignment of the position feedback sensor sources to the upper and lower end positions is arbitrary .

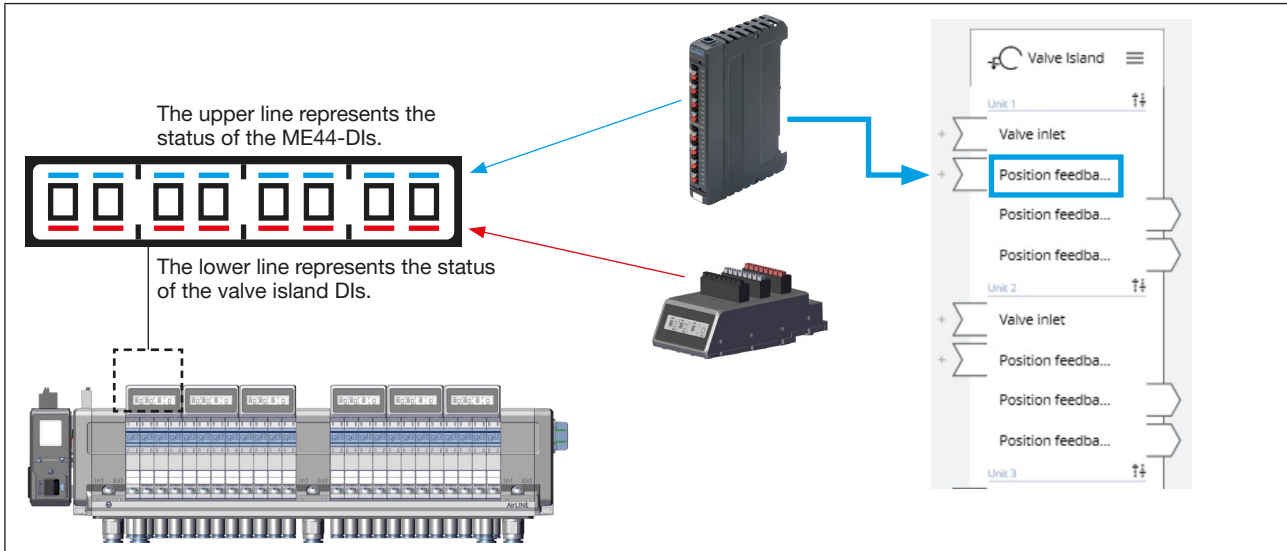

→ Connect the ME44-DIs to a position feedback sensor input.

→ Once all connections have been made, select **Apply changes** .

All configured devices are re-started.

! The assignment of the position feedback sensor inputs must be created separately for each valve unit!

20.3.2 Example 2: Valve island with 6 valve units without internal DI modules in combination with 8DI modules ME44

A maximum of 2 DI modules are possible per valve unit. In the case of a valve island with 6 valve units without internal DI modules, a maximum of 12 external 8DI modules can be used.

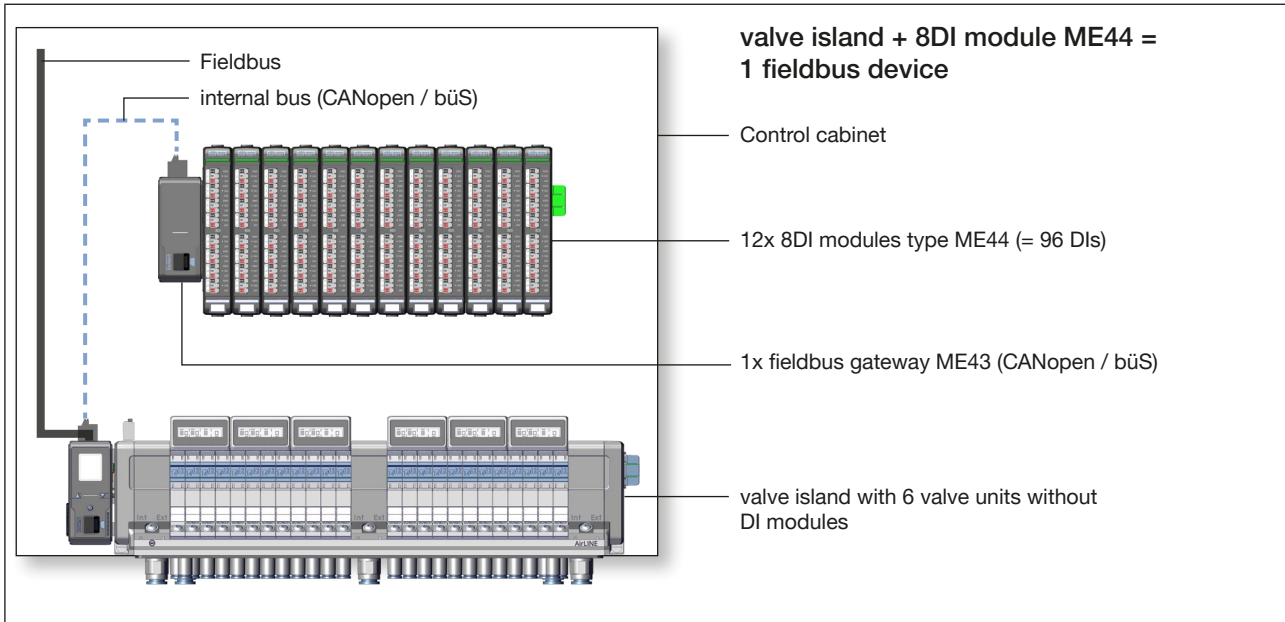

Network configuration in the communicator:

In the figure below, the following position feedback sensor sources are assigned to the end positions:
Upper end position "External DI module (büS)"
Lower end position "External DI module (büS)"

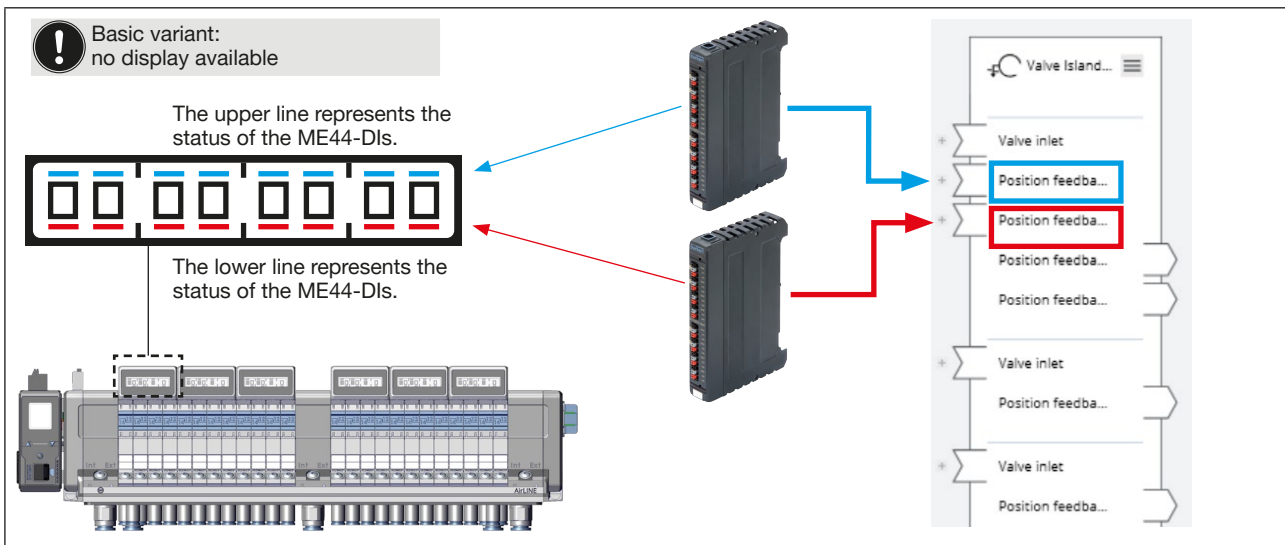

- Connect the ME44-DIs with the position feedback sensor inputs.
- Once all connections have been made, select **Apply changes**.

All configured devices are re-started.

! The assignment of the position feedback sensor inputs must be created separately for each valve unit!

20.3.3 Example 3: Valve island with 6 valve units without internal DI modules in combination with 16DI modules ME64

A maximum of 2 DI modules with 8 DIs each (= 16 DIs per valve unit) are possible per valve unit.

In the case of a valve island with 6 valve units without internal DI modules, 6 16DI modules of type ME64 can be used.

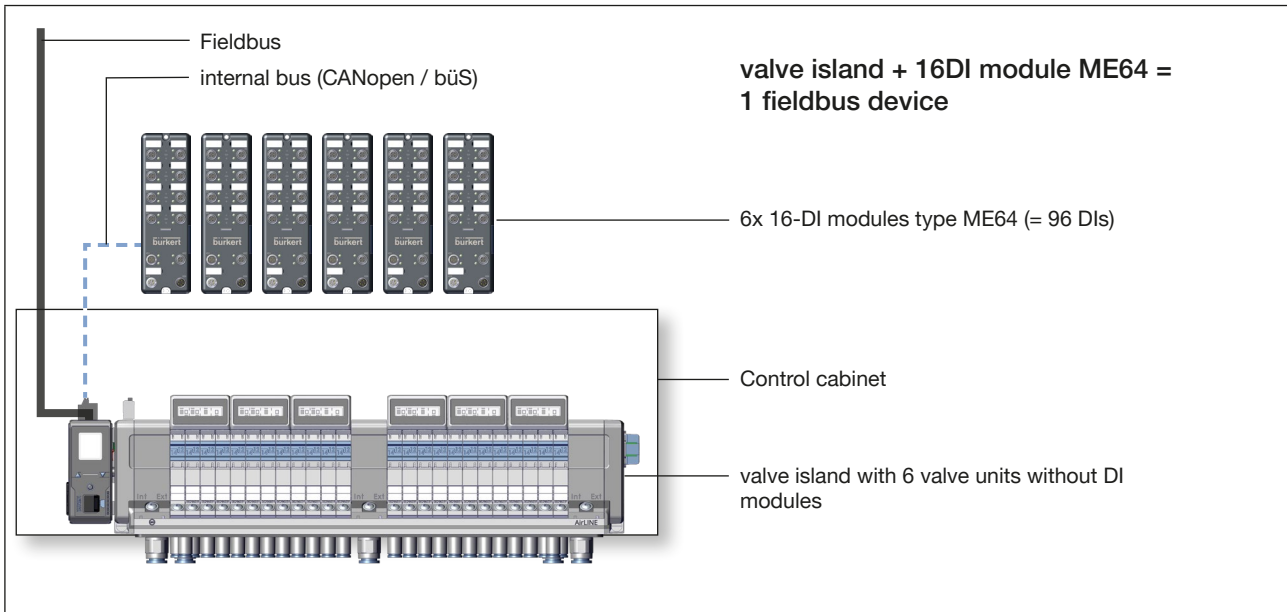

Network configuration in the communicator:

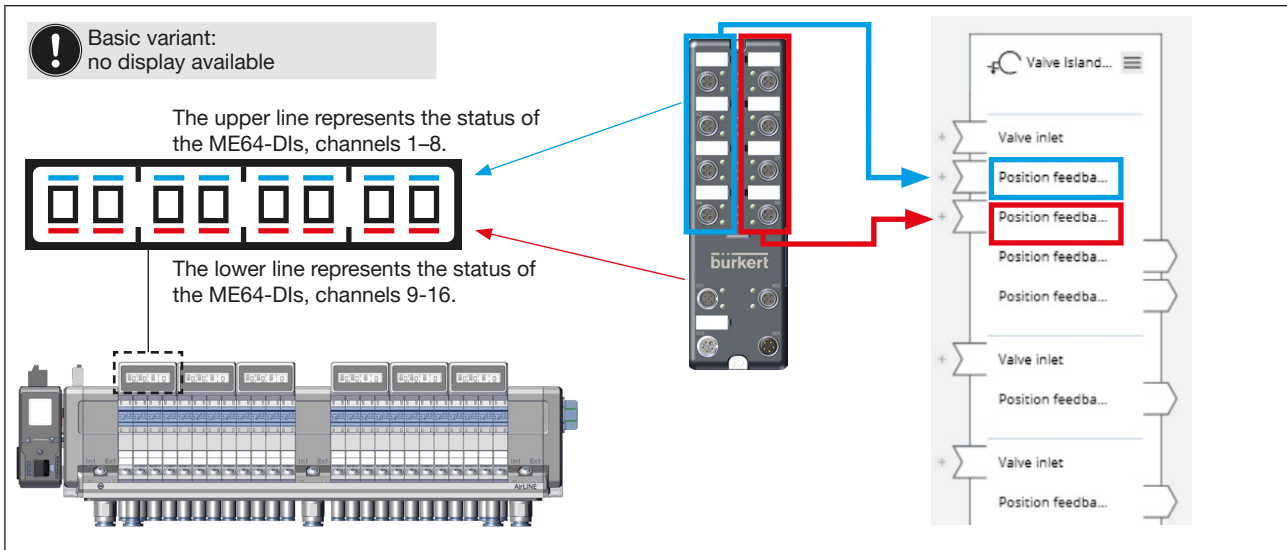

→ Connect the ME64-DIs to a position feedback sensor input.

→ Once all connections have been made, select **Apply changes**.

All configured devices are re-started.

! The assignment of the position feedback sensor inputs must be created separately for each valve unit!

20.4 Show errors from bÜS partners on the display

If the valve island with a DI module Type ME64 or ME44 is used, wire break or short circuit alerts can be indicated on the valve unit display as though it were an internal module.



The settings for this can be made with the Bürkert Communicator software.

In the valve island configuration area :

User level: Installer

→ Select **General settings**.

→ Select Menu **Parameter > bÜS > Advanced > Show errors from bÜS partners**.

→ In the drop-down menu on the right, select **Only Producers**.

In the configuration area ME44 or ME64 :

User level: Installer

→ Select **Inputs**.

→ Switch off **Mark bus-outputs as invalid**.

→ If desired, activate **Wire break detection active**.

20.5 Configure external DI modules using a wizard

If the configuration is identical for each valve unit, it is recommended to use a wizard in the Bürkert Communicator.

→ Assign the position feedback sensor sources in the automation software (see [“20.1”](#)).

In the Bürkert Communicator, valve island configuration area  :

User level: Installer

→ Select **General settings**.

→ Select Menu **Parameter** > **Configuration of external DI modules**.

 A wizard guides you through the settings:

Page 1 of the wizard

→ In the selection field on the right, select the end position that is transferred from the external DI module.
The assignment to the end position and the setting for wire break detection apply to all valve units (see also Chapter [“8.5 Electrical connection assignment”](#) on page 39).

Page 2 of the wizard

In the selection field on the right, select the value for each valve unit that is reported by the external DI module.

21 SWITCH TIME MONITORING FUNCTION

With this function, wear or possible defects in the process valves (actuators) can be detected early by monitoring the switching time duration, e.g. to optimise maintenance intervals.

The valve island can record and permanently monitor the switching times of individual or all actuators in the ongoing process. Once a process parameter changes and this affects the switching time of the actuators, this is recorded and a maintenance notification is sent to the controller. The device changes the Namur Status to blue. The display shows the channel on which the deviation is present.

The set-up operation takes place in the background and has no impact on the process.

21.1 What exactly is being measured?

The time from switching the pneumatic valve to the end position feedback is measured.

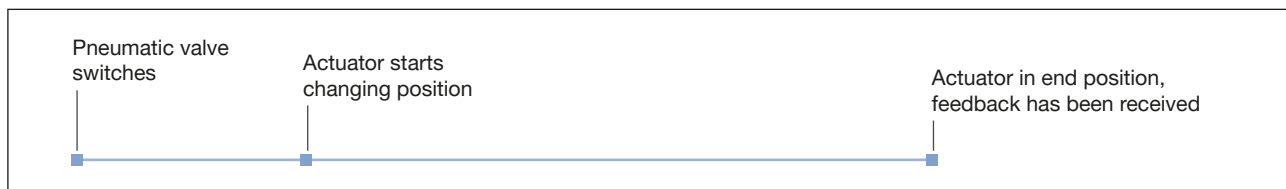

Figure 44: Time span of the switching time measurement

21.2 Settings for the actuator switching time

21.2.1 Tolerance (permissible deviation of the actuator switching time)

An average value is determined from 20 consecutive actuator switching times.

The permissible range in which this average value may be exceeded or not reached can be set by the user as a percentage. The default value of the tolerance is 50%.

If values outside the permissible range are determined 3 times in succession, a maintenance message is issued.

Example:

The average value determined is 5 s.

With a 50% tolerance, this results in a permissible range of 2.5 s to 7.5 s.

If 3 measurements <2.5 s or >7.5 s are determined in succession, a maintenance message is issued.

Exceeding the permissible tolerance range can indicate the beginning of wear on the actuator, a leak in the pneumatic supply branch from the valve island to the actuator or fluctuations in the compressed air network.

21.2.2 Timed out

The default value for the timeout is 60 s.

If the switching time measurement has been carried out, 3 times the value of the determined average value applies to the timeout instead of the default value.

If this value is exceeded once, a maintenance message is issued.

Example:

The average value determined is 5 s, resulting in a timeout of 15 s.

If a switching time >15 s is measured, a maintenance message is issued immediately.

A timeout indicates a malfunction of the actuator, e.g. due to a loose hose or a seizure of the actuator.

21.3 Start switching time measurement

The switching time measurement can be started using the Bürkert Communicator software, the web server or an external controller.

21.3.1 Requirements for correct switching time measurement

- Position feedback sensor units are connected and working
- Measurements take place under standard process conditions
- Compressed air supply is stable

21.3.2 Start switching time measurement via Bürkert Communicator

→ Make sure that the "Installer" user level is active (see chapter "15.1 User levels")

→ Select **Unit X** (the switching time measurement must be started / stopped separately for each valve unit).

→ Select **Parameter** > **Actuator switching time** > **Measurement**.

→ Mark the desired feedback inputs.

→ Start of measurement: **Yes**

→ **Finish**

The valve island measures the actuator switching time.

Measurement information

During the measurement, the message **Actuator runtime measurement active** is displayed in the Communicator.

The progress of the measurement can be read under **Parameter** > **Actuator switching time** > **Measurement** > **Finish**. Inputs for which the measurement has been completed are no longer marked.

After the measurement, the values can be read under **Unit X** > **Diagnostics** > **Channel maintenance**.

21.3.3 Start switching time measurement via web server

→ Select Menu **Switching time monitoring**.

→ Select unit (the switching time measurement must be started / stopped separately for each valve unit).

→ Select the desired position feedback sensor inputs.

→ **Start measurement**.

The valve island measures the actuator switching time.

Measurement information

While the measurement is running, the **Start measurement** button is greyed out in the **Switching time monitoring** menu.

After the measurement, the values can be read in the **Maintenance** menu.

21.3.4 Switching time measurement start via external controller

The objects for starting the switching time measurement via an external controller can be found in the "Device Description files" on the Bürkert homepage under:



country.burkert.com → Type 8652 → Software → Device Description files

21.4 Error messages for the function of the switching time monitoring

If the tolerance value of the actuator switching time is exceeded, a maintenance message is sent to the controller. The display of the corresponding valve unit shows the channel on which the deviation is present (see also "[19 Display electronic module](#)" on page 100).

As soon as 1 correct measurement is taken again, the error message on the display disappears and the controller is informed.

22 MICRO SD CARD

A micro SD card is available as an accessory for the valve island. The micro SD card can be used to store device-specific values and user settings and transfer them to another device.



If the micro SD card of the device is re-inserted at a later stage, the data last saved are not restored. The micro SD card will not transfer the stored data to the same device.

Note!

By resetting the device to the factory settings, the data saved on the SD card are also reset.

A newly created micro SD card is checked for the presence of existing data when the device is re-started. This data will be transferred or overwritten accordingly:

- The micro SD card does not contain any data.
The existing device-specific values and user settings are saved to the micro SD card.
- The micro SD card contains data compatible with the device.
The data on the micro SD card are transferred by the device. The existing device-specific values and user settings are overwritten..
- The micro SD card contains data that are not compatible with the device.
The device overwrites the data on the micro SD card with its own device-specific values and user settings.

CAUTION

The micro SD card used is a special industrial version that offers additional durability and temperature-resistance.

- ▶ Do not use a standard micro SD card for the device. Only purchase the micro SD card for the device from your Bürkert sales department.

Replacing the micro SD card

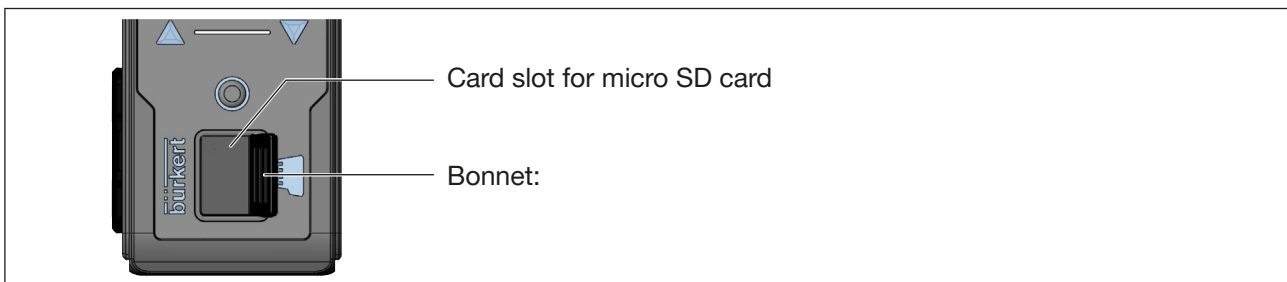

Figure 45: Change micro SD card

NOTE!

Do not remove the SD card while the supply voltage is applied.
If the SD card is removed while the supply voltage is applied, data may be lost and the SD card may be damaged.



The SD card can be inserted while the device is connected to the supply voltage.
A restart is required to ensure that the device detects the SD card.

Removing the micro SD card:

→ Pull the cover out of the recess and turn it to the top left.

→ To unlock, press on the edge of the engaged micro SD card, Remove micro SD card.

Insert the micro SD card into the replacement device:

⚠ Observe the direction of insertion when inserting the card.

→ Slide the micro SD card into the card slot. Make sure that the micro SD card locks into position.

→ Close card slot with bonnet.

22.1 Display of memory operation on the fieldbusgateway

If a memory operation has occurred between the gateway and the SD card during device restart, the display shows a notification to that effect.

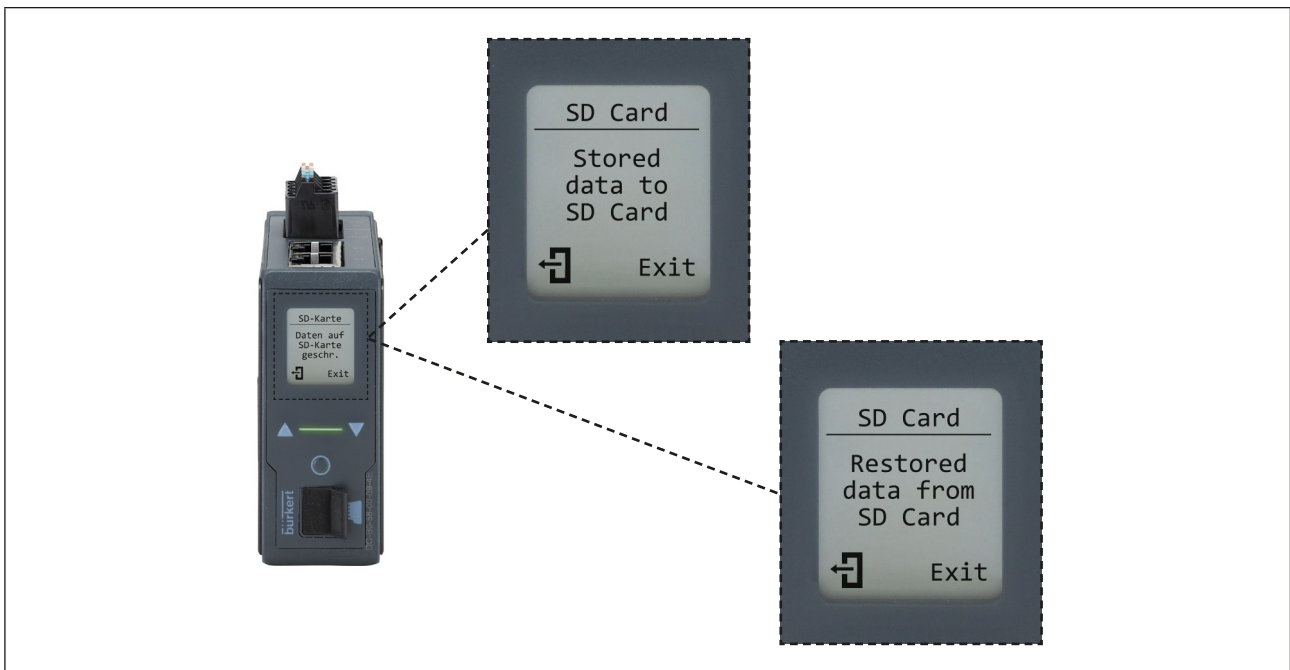

23 BACKUP BATTERY

The device is equipped with a backup battery. The function of the battery relates exclusively to the time recording in the logbook.

If the battery is empty, it will not cause a fault in the device. There is only a message in the Bürkert Communicator software.

24 REPLACING SPARE PARTS

WARNING

Risk of injury due to improper installation work.

- ▶ Only trained technicians may perform installation work.
- ▶ Perform installation work using suitable tools only.

The following modules are available as spare part kits or for retrofitting for the valve island AirLINE Type 8652 under the type SV04:

- Connection module
- Electronic module
- Pneumatic valves

If modules with modified functions are used, the modifications must be adapted accordingly in the device configuration. This can be achieved via the Bürkert Communicator software or via the web server, in some cases also via the display of the fieldbus gateway ME43 (pressure sensor and valve configuration).

24.1 Connection module with compressed air supply

Connection module with compressed air supply can be equipped with an additional port for the compressed air supply. This additional port is advantageous, e.g., for easier tubing when the compressed air source is located in the control cabinet.

Variant	Port size	Order no.
With an additional port for the compressed air supply	Plug-in coupling Ø 6 mm and Ø 10 mm	384863
	Plug-in coupling Ø 1/4" and Ø 3/8"	384864
Without an additional port for the compressed air supply		384866

Table 14: Overview of the "connection module without pressure sensor" variants

24.1.1 Replacing the connection module

DANGER

Danger due to high pressure, escaping medium and uncontrolled movement of the actuators.

- ▶ Secure the actuators against shifting before working on the device or plant.
- ▶ Switch off the pressure before working on the device or plant. Vent or empty the lines.

NOTE

Internal short circuit between the auxiliary pilot air and the pilot pressure.

To avoid an internal short circuit, the seals of the connection modules must be positioned the same (external or internal supply of auxiliary pilot air). Mixing the external or internal supply is not permitted.

- ▶ Never mix the external or internal supply.
- ▶ Note chapter "9.1.1 External and internal auxiliary pilot air" on page 45.

 The X port always has to be connected for an external supply.

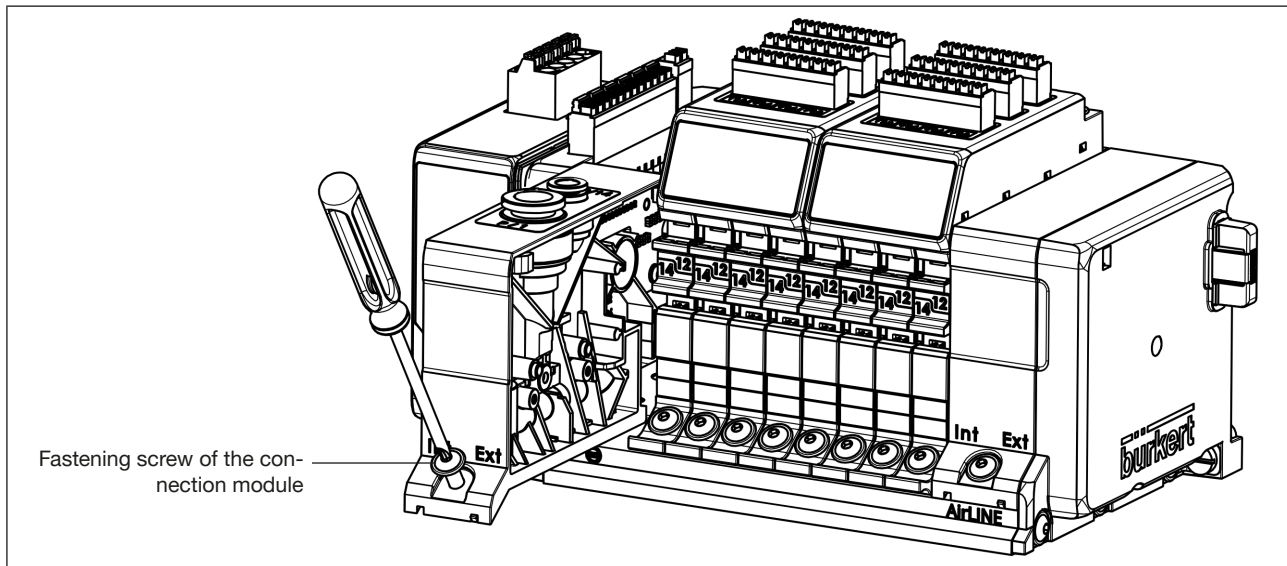

-  Observe the safety instructions.
- Use a screwdriver (TX 20) to undo the fastening screw of the connection module.
- Extract the connection module from the front.
- Insert the new connection module and screw it into position (tightening torque 2 Nm).

24.2 Connection module with pressure sensor

The connection modules with pressure sensor are always equipped with an additional port for the compressed air supply. The following variants are available:

Variants	Order no.
Port for the compressed air supply: Plug-in coupling Ø 6 mm and Ø 10 mm	384867
Port for the compressed air supply: Plug-in coupling Ø 1/4" and Ø 3/8"	384868

Table 15: Overview of the "connection module with pressure sensor" variants



Due to technical reasons, a connection module with pressure sensor cannot be used with devices purchased before 1 July 2020.

24.2.1 Replacing the connection module



DANGER

Danger due to high pressure, escaping medium and uncontrolled movement of the actuators.

- ▶ Secure the actuators against shifting before working on the device or plant.
- ▶ Switch off the pressure before working on the device or plant. Vent or empty the lines.



CAUTION

Risk of injury due to electrical voltage.

- ▶ Switch off the power supply before working on the device or system. Secure against reactivation.
- ▶ Observe the applicable accident prevention and safety regulations for electrical devices.

CAUTION

Electrostatically sensitive components and assemblies.

The device contains electronic components that are susceptible to the effects of electrostatic discharging (ESD). Components that come into contact with electrostatically charged persons or objects are at risk. In the worst case scenario, these components will be destroyed immediately or fail after start-up.

- ▶ Meet the requirements specified by EN 61340-5-1 to minimise or avoid the possibility of damage caused by a sudden electrostatic discharge.
- ▶ Do not touch electronic components when the supply voltage is connected.

NOTE

Internal short circuit between the auxiliary pilot air and the pilot pressure.

To avoid an internal short circuit, the seals of the connection modules must be positioned the same (external or internal supply of auxiliary pilot air). Mixing the external or internal supply is not permitted.

- ▶ Never mix the external or internal supply.
- ▶ Note chapter "9.1.1 External and internal auxiliary pilot air" on page 45.



The X port always has to be connected for an external supply.

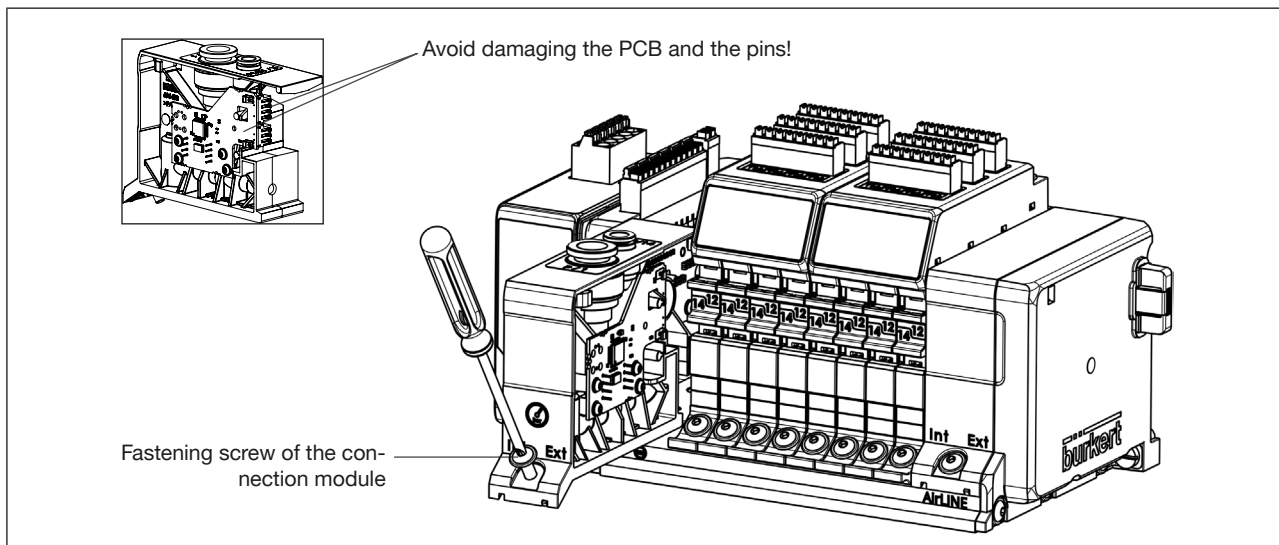

-  Observe the safety instructions.
- Ensure the PCB and the pins of the new connection module are not damaged during all stages of the assembly process.
- Use a screwdriver (TX 20) to undo the fastening screw of the connection module.
- Extract the connection module from the front.
- Insert the new connection module into a free slot and screw it into position (tightening torque 2 Nm).
- Adapt the modified device configuration (pressure sensor), if necessary (via Bürkert Communicator software, ME43 display or web server).

24.3 Electronic module

The electronic module is available in the following variants:

Variants	Order no.
Electronic module with digital inputs	384872
Electronic module without digital inputs	384873

Table 16: Overview of “electronic module” variants

24.3.1 Replacing the electronic module

CAUTION

Irreparable damage to the fieldbus gateway.

If an electronic module is detached from an energised valve island, the electronics of the fieldbus gateway may be destroyed.

- ▶ Therefore, always switch off the voltage before unscrewing the electronic module from the valve island. Secure it against reactivation.

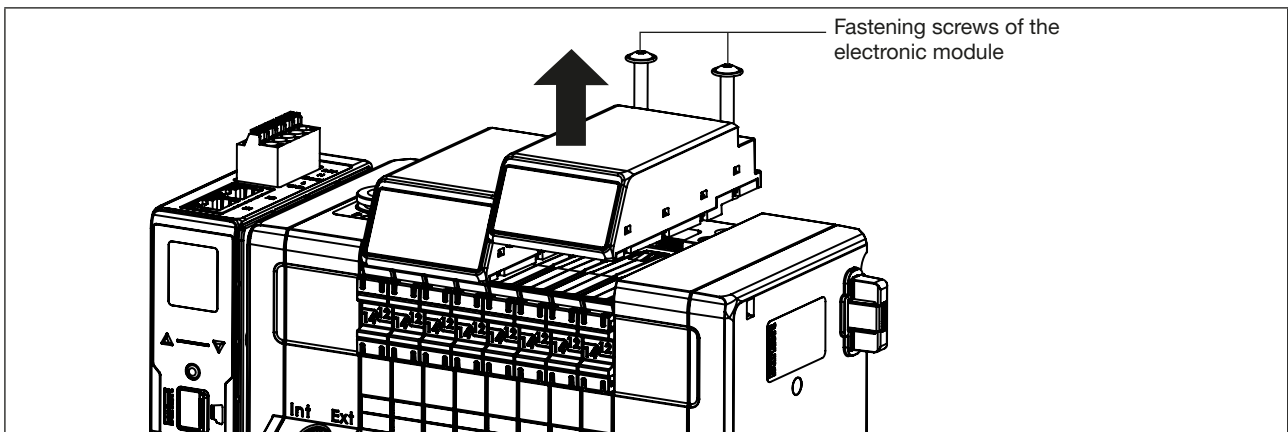

-  Observe the safety instructions.
- Use a screwdriver (TX 20) to undo the fastening screws of the electronic module.
- Extract the electronic module from the top.
- Insert the new electronic module into a free slot and screw it into position (tightening torque 2 Nm).
- Adapt the modified device configuration (digital inputs), if necessary (via Bürkert Communicator software or web server).

24.4 Pneumatic valves

Pneumatic valves are available in the following variants:

Variants	Order no.
2x CFC (2x 3/2-way normally closed)	301374
2x CFD (2x 3/2-way normally open)	301375
CF H (5/2-way monostable)	301376
CFZ (5/2-way bistable)	301377
CFM (5/3-way pressurised)	301379
CFL (5/3-way blocked)	301380
CFN (5/3-way vented)	301381
Blind valve	335779
2x CFC SIA (2x 3/2-way normally closed)	338802
CF H SIA (5/2-way monostable)	338805
CFL SIA (5/3-way blocked)	346830

Table 17: Overview of "pneumatic valve" variants

24.4.1 Replacing a pneumatic valve

DANGER

Risk of injury due to high pressure and escaping medium at valve islands without hot swap function.

- ▶ At valve islands without hot swap function, secure the actuators against shifting before working on the device or plant.
- ▶ At valve islands without hot swap function, switch off the pressure before working on the device or plant. Vent or empty the lines.

Risk of injury due to high pressure and escaping medium at valve islands with hot swap function.

When dismantling a valve, lines and actuators may still be pressurised, which can cause uncontrolled movement of the actuator.

- ▶ At valve islands with hot swap function, secure the actuators against shifting before working on the device or plant.

At valve islands with hot swap function, the valves can be replaced under pressure.



To ensure safe dismantling of the valve from the valve island, there must be sufficient space to extract the valve from the front. In this case, the minimum distance between the valve island and the front edge of the control cabinet must be taken into account (see chapter "7.1" on page 28).

If there is not sufficient space to the front edge of the control cabinet, proceed as specified in chapter "24.4.2 Replacing a pneumatic valve (without minimum distance)" on page 123 when replacing a valve. In this case, the hot swap function is disabled!

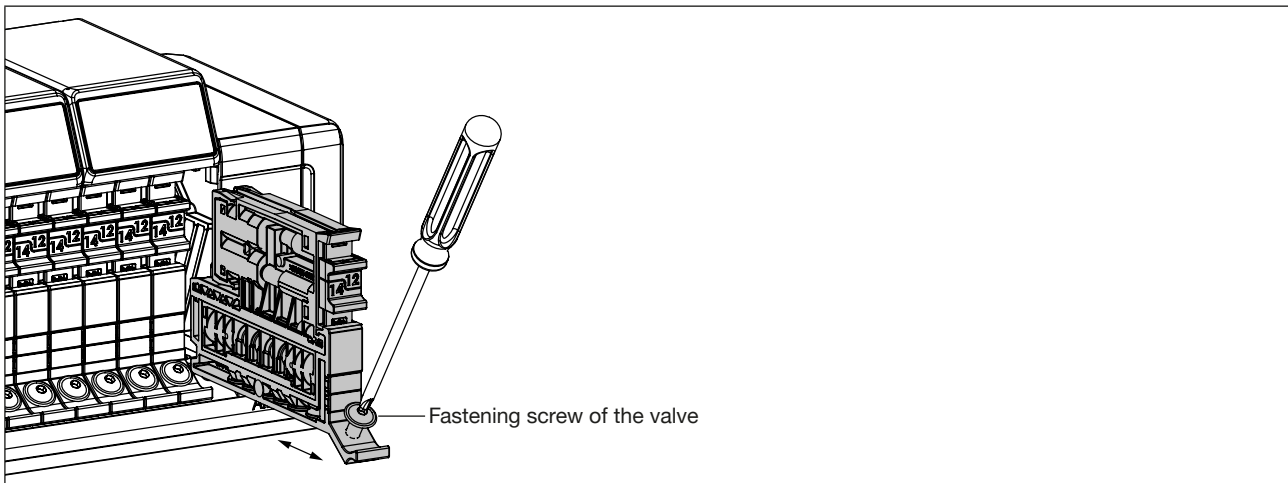



Figure 46: Replacing a valve.

-  Observe the safety instructions.
- Use a screwdriver to undo the fastening screw of the valve.
- Extract the valve from the valve island.



If the device is used for a longer period of time, the seal of the valves may stick to the supply manifold. An increased amount of force may, therefore, be required to release the valves from the valve island.

- Insert a new valve into the valve slot.
- Tighten the fastening screw (tightening torque 2 Nm).
- Adapt the valve configuration, if necessary (via Bürkert Communicator software, ME43 display or web server).

24.4.2 Replacing a pneumatic valve (without minimum distance)

DANGER

Danger due to high pressure, escaping medium and uncontrolled movement of the actuators.

- ▶ Secure the actuators against shifting before working on the device or plant.
- ▶ Switch off the pressure before working on the device or plant. Vent or empty the lines.

CAUTION

Irreparable damage to the fieldbus gateway.

If an electronic module is detached from an energised valve island, the electronics of the fieldbus gateway may be destroyed.

- ▶ Therefore, always switch off the voltage before unscrewing the electronic module from the valve island. Secure it against reactivation.

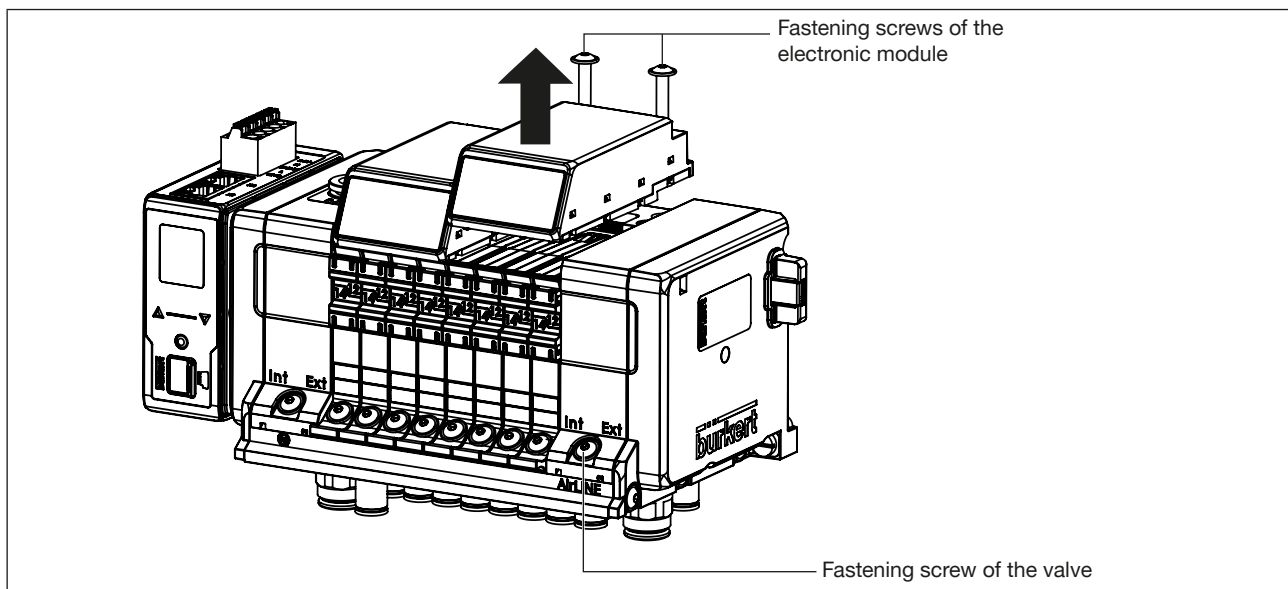



Figure 47: Replacing a valve without minimum distance to the front edge of the control cabinet

If the minimum distance to the front edge of the control cabinet is too small to extract a pneumatic valve from the front of the valve island, a pneumatic valve can also be extracted from the top of the valve island if the electronic module has been dismantled in advance. In this case, the hot swap function is disabled.

-  Observe the safety instructions.
- Use a screwdriver to undo the fastening screws of the electronic module and the valve.
- Extract the electronic module from the top.
- Extract the valve from the top of the valve island.
- Insert a new valve into the valve slot.
- Re-insert the electronic module into the valve island.
- Tighten the fastening screws of the electronic module and the valve (tightening torque 2 Nm).
- Adapt the valve configuration, if necessary (via Bürkert Communicator software, ME43 display or web server).

24.4.3 Replacing valves CFZ or CFZ*



WARNING

Danger due to uncontrolled movement of the actuators.

→ For valves with hot swap function, secure the actuators against shifting before working on the device or plant.

For valves with circuit function Z and circuit function Z*, depending on the switch position, either

Output 2 is aerated and Output 4 is vented
or
Output 2 is vented and Output 4 is aerated.

Valves with circuit function Z*

The valve island software ensures that the newly installed valve adopts the switch setting of the original valve in the event that a valve is replaced (hot swap).

For valves with circuit function Z*, manual override is disabled after initial electrical activation.

Valve with circuit function Z

Replaced valves with circuit function Z take on an undefined switch position.

25 REPLACE THE ME43 FIELDBUS GATEWAY

WARNING

Danger due to uncontrolled movement of the actuators.

- ▶ Secure the actuators against shifting before working on the device or plant.
- ▶ Switch off the pressure before working on the device or plant. Vent or empty the lines.
- ▶ Switch off the power supply before working on the device or system. Secure against reactivation.

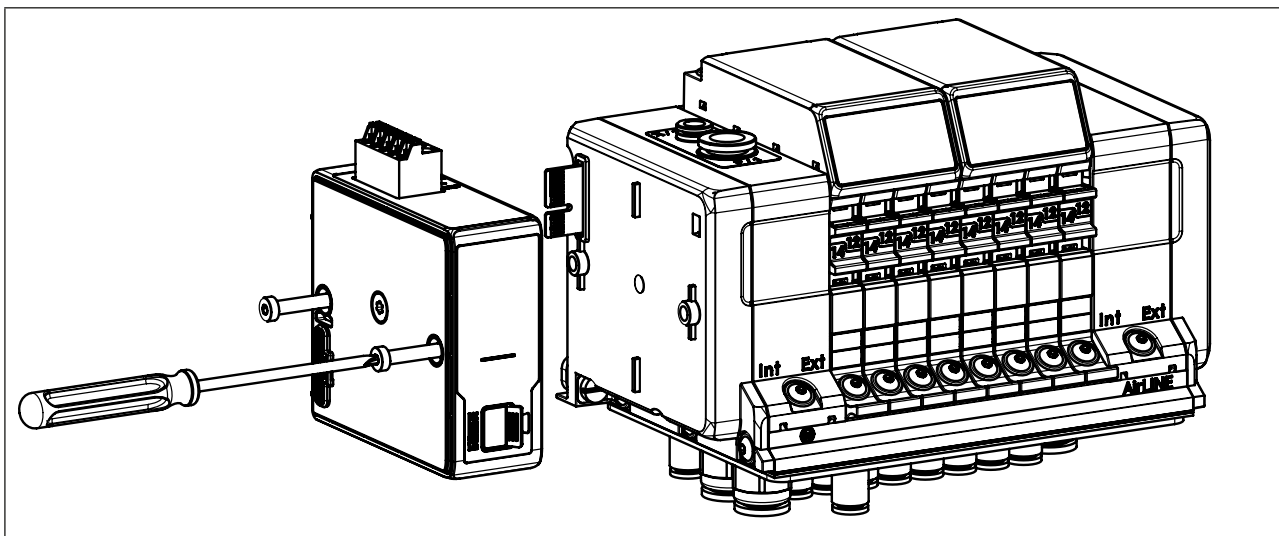



Figure 48: Replacing the fieldbus gateway

-  Observe the safety instructions.
- Loosen the electrical connections.
- Loosen the fastening screws of the gateway with a screwdriver.
- Detach the gateway to the left from the valve island.
- Remove the micro SD card.
- Insert the micro SD card in the new gateway (note the direction of insertion!).
- Place the new gateway on the standard rail and push it onto the valve island so that the gateway is connected to the valve island.
- Tighten the fastening screw (tightening torque 1 Nm).
- Connect the gateway electrically.

26 BASIC VARIANT: RETROFITTING ELECTRONIC MODULE

26.1 Mounting an electronic module on the valve island

-  Switch off the supply voltage.
- Use a screwdriver (TX 20) to undo the fastening screws of the protective cover on the electronic module.
- Pull the protective cover upwards.
- Insert the electronic module into a suitable free slot and screw it into position (tightening torque: 2 N⊂m).

26.2 Configuring the electronic module

When retrofitting electronic modules, the displays of the valve units must be activated in the Communicator/web server or on the display of the fieldbus gateway.

If the electronic modules are equipped with DI modules and these are to be used as the position feedback sources, the DI modules must be set as the position feedback source in the Communicator/web server.

If DI modules are set as the position feedback sources, the valve unit displays are automatically activated. If the DI modules are deactivated as position feedback sources, the displays are automatically deactivated, too.

 **Recommendation:**
Activate the displays first and then set the DI modules as the position feedback sources. That way, the displays will remain activated, even if the DI modules are deactivated as position feedback sources.

26.2.1 Activating the valve unit displays

This setting can be made in the Communicator, on the web server or on the gateway display.

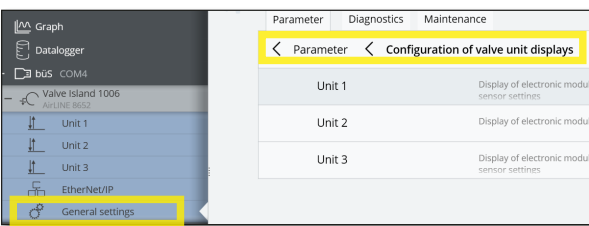
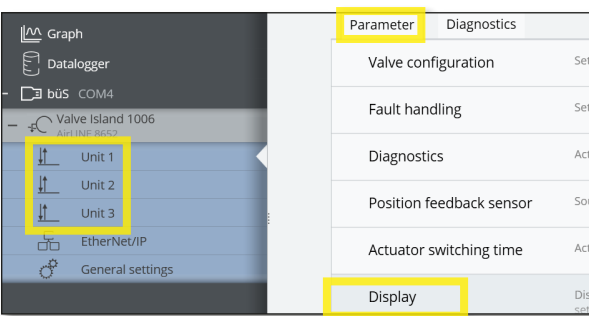



In the Communicator:

- Under **General settings** > **Parameter** > **Configuration of valve unit displays**, activate the relevant displays.

Or:

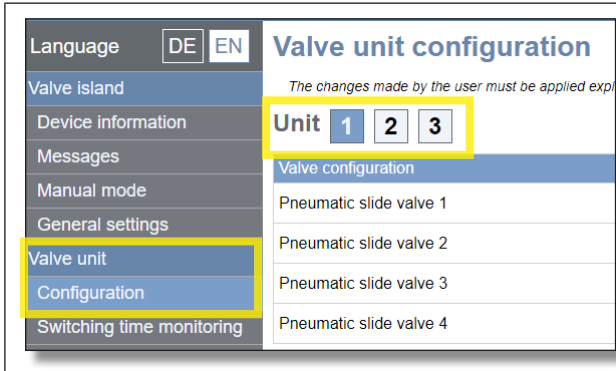
- Under **Unit X** > **Parameter** > **Display**, activate the display.
- Repeat this process for additional valve units as necessary.



In the web server:

- Select **Valve unit** > **Configuration**.
- Select the unit.
- Then under **Display**, activate the display.
- Repeat this process for additional valve units as necessary.

On the display of the fieldbus gateway:

- Press menu button twice.
- **Parameter** > **AirLINE** > **Display cnf** > **All disp.** or select a single **Unit**, select **Active** and confirm with the menu button.
- Return to the home screen by clicking **Exit** and restart.

26.2.2 Setting the DI module as the position feedback source

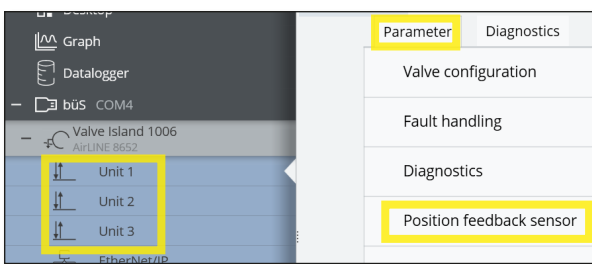

In the Communicator:

- Under **Unit X** > **Parameter** > **Position feedback sensor** set the “Integrated DI module” as the source in accordance with the valve configuration.
- Repeat this process for additional valve units as necessary.

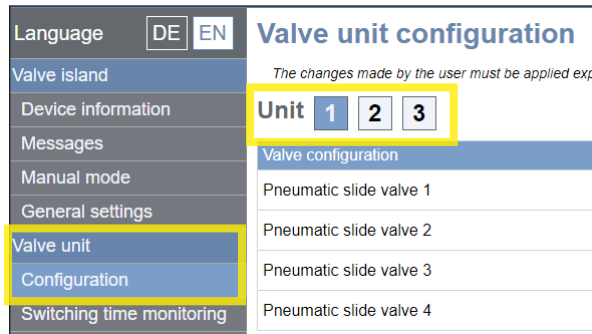

In the web server:

- Select **Valve unit** > **Configuration**.
- Select the unit.
- Then under **Position feedback**, set the “Integrated DI module” as the source in accordance with the valve configuration.
- Repeat this process for additional valve units as necessary.

27 MAINTENANCE, TROUBLESHOOTING

27.1 Safety instructions

! WARNING

Risk of injury due to improper maintenance work.

- ▶ Maintenance may be carried out by authorised technicians only and with the appropriate tools!

Risk of injury due to unintentional activation of the system and uncontrolled restart.

- ▶ Secure the system against unintentional activation.
- ▶ Ensure a controlled restart after maintenance is completed.

27.2 Replace filter for auxiliary pilot air

! DANGER

Risk of injury due to high pressure and escaping medium.

- ▶ Secure the actuators against shifting before working on the device or plant.
- ▶ Switch off the pressure before working on the device or plant. Vent or empty the lines.

! The filter is available as an accessory from Bürkert (see chapter [“29 Accessories”](#) on page 136).

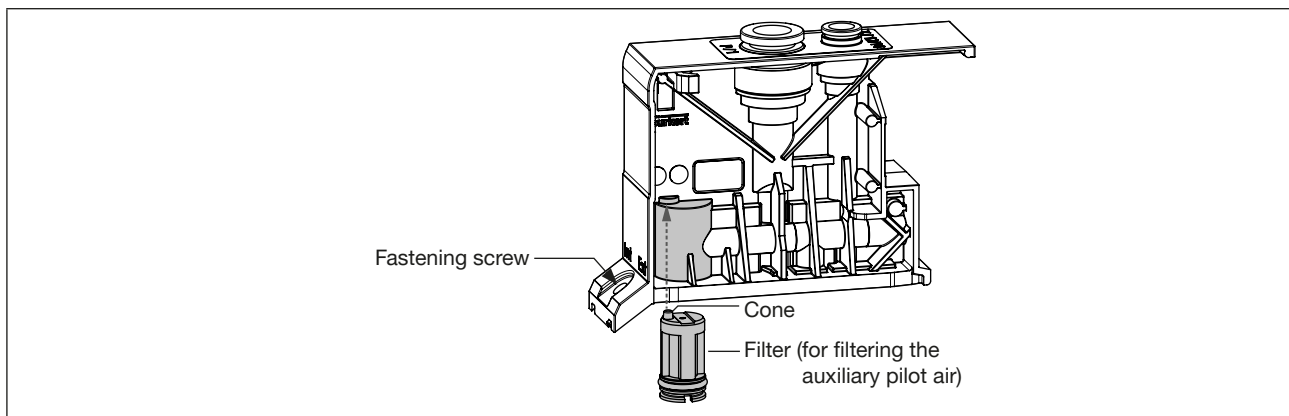

Figure 49: Replacing the filter

- Use a screwdriver to undo the fastening screw of the connection module.
- Extract the connection module from the front.
- Pull out the filter with a slotted screwdriver
- Insert a new filter. Make sure that the cone of the filter hits the hole provided.
- Insert the connection module and screw it into position (tightening torque 2 Nm).

27.3 Troubleshooting

Fault	Possible cause	Remedy
Valves do not switch	no or too low load voltage	Check the electrical connection ensure correct load voltage
	Manual override of the valves not in neutral position	Bring the manual override into the neutral position
	Pressure supply insufficient or not available	Set up the largest possible volume of pressure supply (also for upstream devices such as pressure regulators, maintenance units, on/off valves, etc.)
		for valves without auxiliary pilot air: Ensure a minimum operating pressure of 3.0 bar and observe the ratio of pilot pressure to medium pressure in accordance with the pilot pressure diagram (see Chapter "6.6.1" on page 21)
	wrong configuration	Configure the system according to the hardware structure
	Channel not released for use	Changing the setting of the parameters (Communicator)
	24 V supply not connected or incorrectly contacted	Make sure the 24 V supply is connected correctly
for SIA variant: Connection terminal with bridge or connected cable not connected	Connect connection terminal with bridge or connected cable	
Valves switch with a delay or blow off at the exhaust ports	Pressure supply insufficient or not available	Set up the largest possible volume of pressure supply (also for upstream devices such as pressure regulators, maintenance units, on/off valves, etc.)
		for valves without auxiliary pilot air: Ensure a minimum operating pressure of 3.0 bar and the ratio of pilot pressure to medium pressure in accordance with the pilot pressure diagram (see Chapter "6.6.1" on page 21)
	Pressure build-up of pilot pressure insufficient	With 5/2-way valves (CF H) and 2x3 / 2-way valves (CF D, open when de-energised), operate the valve island with an external pilot pressure supply
	Valves are not in home position (de-energised) during pressure build-up	Apply pressure to the valve block before switching the valves
	Insufficient ventilation of the exhaust air ducts due to too small or dirty silencers (back pressure)	Use suitably sized silencers or expansion vessels
		Clean the dirty silencers
	Impurities or foreign bodies in the pilot valve	Change valve
Impurities or foreign bodies in the filter	Clean the filter by blowing it out with compressed air or replace the filter	

27.4 Error messages on the LC display of the electronic modules

An overview of the possible display contents is given in Chapter [“19 Display electronic module”](#) on page 100.

Message	Possible cause	Remedy
no message, LC display off	no or too low load voltage	Check the electrical connection ensure correct load voltage
	Voltage interruption during firmware update	Carry out the firmware update again
Pilot SCC Limit Ch. X or Act. SCC limit Ch. X	Maintenance limit for pilot valve / actuator channel X reached	Replace the pilot valve or service the actuator and reset the switching cycle counter or Deactivate switching cycle counter or Increase warning limit switching cycle counter
Short Circuit Ch. X	Short circuit on input x of the position feedback sensor unit (position feedback sensor or plug connection defective)	Check position position feedback sensor sensor / plug connection or Replace position feedback sensor
Wire Break Ch. X	Wire break on input x of the position feedback sensor unit (position feedback sensor or plug connection defective)	Check position position feedback sensor sensor / plug connection or Replace position feedback sensor
EVS active	24 V supply not connected or incorrectly contacted	Check correct connection
	Electric circuit of a valve unit interrupted due to the shutdown function “Module-based safety shutdown”	
Act Sw. Time	The tolerance value of the actuator switching time has been exceeded.	Maintain actuator (see chapter “21.4”)

27.5 Description of the error code

Error code	Description
1/3	Overload detected.
2/1	Overvoltage detected.
2/2	Undervoltage detected.
2/3	Voltage warning limit exceeded.
2/4	Voltage warning limit undershot.
2/5	Battery voltage warning limit undershot.
2/6	Voltage drop detected.
3/1	Excess temperature detected.
3/2	Low temperature detected.
3/3	Temperature warning limit exceeded.
3/4	Temperature warning limit undershot.
18/4	SD card is defective.
18/7	Removable storage present.
18/8	No access to the removable storage possible.
18/9	Configuration is being successfully managed by another device.
18/10	Configuration is NOT being successfully managed by another device.
18/11	Unable to load device configuration via the configuration provider.
18/12	At least 1 device is missing.
18/13	Bürkert Communicator is required.
18/14	Device must be replaced.
18/15	Device cannot be replaced as there are too many options present. Reduce the number of compatible devices.
18/16	Problems when replacing device.
18/17	Problems when replacing device. Unable to write to at least 1 object.
18/18	Device replacement failed.
18/19	Device replacement completed successfully.
18/20	Configuration provider is not active as no memory card has been detected.
18/21	More than 1 configuration provider is active! Switch off the other provider functions.
19/1 ... 19/6	Unit 1 ... Unit 6: Limit of switching cycle counter for pilot valve reached. Replace pilot valve.
19/7 ... 19/12	Unit 1 ... Unit 6: Maintenance limit for actuator reached.
19/13 ... 19/18	Unit 1 ... Unit 6: Short circuit on the upper position feedback sensor unit.
19/19 ... 19/24	Unit 1 ... Unit 6: Short circuit on the lower position feedback sensor unit.
19/25 ... 19/30	Unit 1 ... Unit 6: Wire break on the upper position feedback sensor unit.
19/31 ... 19/36	Unit 1 ... Unit 6: Wire break on the lower position feedback sensor unit.
19/37 ... 19/42	Unit 1 ... Unit 6: Maintenance required for actuator (routine maintenance).
19/45 ... 19/50	Unit 1 ... Unit 6: Switching time of the upper feedback position of a valve outside the valid range.
19/51 ... 19/56	Unit 1 ... Unit 6: Switching time of the lower feedback position of a valve outside the valid range.

Error code	Description
19/57	EVS (external valve shutdown) is active on one unit.
19/58	EVS (external valve shutdown) is active on a unit or the device has no power supply (24 V) for pneumatic valves.
19/59 ... 19/64	Unit 1 ... Unit 6: Short circuit on an input of the position feedback sensor unit.
19/65 ... 19/70	Unit 1 ... Unit 6: Wire break on an input of the position feedback sensor unit.
31/1 ... 31/6	Unit 1 ... Unit 6: Overload detected.
31/7 ... 31/8	Electronic module defective.
31/9	Valve control defective.
31/10 ... 31/15	Unit 1 ... Unit 6: Internal connection to the digital inputs of the electronic module interrupted.
31/16 ... 31/21	Unit 1 ... Unit 6: Internal connection to the display of the electronic module interrupted.
31/28	Internal connection to the display of the fieldbus gateway interrupted.
31/29	EVS status cannot be read
31/31	Internal connection to the left pressure sensor interrupted.
31/32	Internal connection to the middle / right pressure sensor interrupted.
31/33	Internal connection to the right pressure sensor interrupted.
31/34	Left infeed - pressure limit exceeded.
31/35	Middle/right Infeed - pressure limit exceeded.
31/36	Right Infeed - pressure limit exceeded.
31/37	Left infeed - pressure limit undercut.
31/38	Middle/Right Infeed - pressure limit undercut.
31/39	Right Infeed - pressure limit undercut.
32/1	Capacity of the internal message storage exceeded.
32/130	Initialisation of the device.
32/200	Error in expansion configuration.
32/201	Syntax problem (s) in the extension configuration
33/1	Switch to "Operation" state
33/2	Switch to "Diagnostics active" state.
33/3	Switch to "Maintenance" state
33/4	Switch to "Out of specification" state.
33/5	Switch to "Check function" state.
33/6	Switch to "Error" state
33/7	Switch to AUTO operating state.
33/8	Switch to MANUAL operating state.
33/9	Switch to special operation mode: LED flashing.
33/11	Switch to "off" state.
33/12	Input value simulation active for at least 1 value.
33/13	Output value simulation active for at least 1 value.
33/14	Demo operation mode enabled.
33/15	User-triggered maintenance signal
33/32768	1 status message present.
35/1	EEPROM error detected.

Error code	Description
35/2	At least 1 persistent memory cannot be used.
40/996	Error on 1 or more partner device(s).
45/3	General error.
45/4	Incorrect bÜS status.
45/5	CANopen task command failed.
45/6	Incorrect parameter passed to function.
45/15	Message / data with incorrect length.
45/16	Message transfer failed.
45/17	Confirmation message timed out.
45/128	Mailbox overflowed.
45/129	bÜS mailbox overflowed.
45/130	CANopen mailbox overflowed.
45/131	CANopen response mailbox overflowed.
45/132	Event mailbox overflowed.
45/133	CSDO reply mailbox overflowed.
45/134	BDO reply mailbox overflowed.
45/176	CAN error counter overflow -Bus Off-.
45/177	Input buffer overflow.
45/178	Output buffer overflow.
45/256	bÜS event: bÜS is NOT operational.
45/257	bÜS event: initialisation of communication.
45/512	bÜS event: localisation.
45/768	bÜS event: a device is using the same address.
45/769	bÜS event: A device uses the same serial number.
45/1024	bÜS event: bus connection lost/not available.
45/1280	bÜS event: BDO message memory overflowed.
45/1792	bÜS event: partner search active.
45/1793	bÜS event: producer(s) not found.
45/1794	bÜS event: manually configured device without address. The search can take up to 1 minute.
45/1795	bÜS event: producer assignment faulty.
45/1796	bÜS event: removal of the producer failed.
45/1797	bÜS event: incorrectly configured CANopen device.
45/1798	bÜS event: GCV is configured on both bÜS interfaces.
45/1799	bÜS event: cyclical communication of the producer is not active.
45/2048	bÜS event: saving of persistent bÜS data (do not switch off device).
45/2049	bÜS event: deletion of persistent bÜS data (do not switch off device).
45/2304	bÜS event: router for acyclic data active.
45/2560	bÜS event: incorrect serial number.
45/2561	bÜS event: incorrect configuration of cyclical inputs (not enough filters).
45/2562	bÜS event: incorrect configuration of cyclical values.
45/2816	bÜS event: manager is active.

Error code	Description
45/3072	büS event: monitored device failed.
45/3584	Wait for addressing.
45/4096	Error when initialising the device parameters.
45/4097	Configured address is already being used.
51/1	No correct connection to the process control system.
51/2	The cyclical data traffic was slower than the set timeout parameters.
51/10	Initialisation of the industrial communication.
51/101	Error in the NetX configuration, e.g. when downloading the firmware.
51/102	The industrial communication is switched off.
51/103	No or incorrect mapping file present.
51/104	No protocol firmware available.
51/105	Please select a protocol and restart the device.
51/201	Protocol stack initialisation error.
51/202	Protocol stack configuration error.
51/203	Error sending the MAC address.
51/204	Error registering the object data.
51/205	Error registering the connections, more than 5 specified.
51/206	Incorrect PROFIBUS address, only addresses 1–126 possible.
51/207	Incorrect CC-Link address, only addresses 1–64 possible.
51/208	Incorrect CC-Link baud rate.
51/209	Incorrect IP parameters.
51/300	The fieldbus master is in “Stop” state.
51/303	Error during cyclical data exchange.
51/400	The master attempted to connect a faulty module/sub-module.
63/1	Firmware update is being carried out
63/2 ... 63/7	Unit 1 ... Unit 6: Error on electronics module.
63/8	Reference measurement of the actuator switching time active.
63/9	Invalid limit values for the medium pressure at the left pressure sensor.
63/10	Invalid limit values for the medium pressure at the middle / right pressure sensor.
63/11	Invalid limit values for the medium pressure at the right pressure sensor.
63/12	At least one büS device is in the state: Maintenance.
63/13	At least one büS device is in the state: Out of specification.
63/14	At least one büS device is in the state: Functional test.
63/15	At least one büS device is in the state: Error.
63/16	SD card cannot be read! The data was created with firmware version A.02.XX.XX.
63/17 ... 63/22	Unit 1 ... Unit 6: Reference measurement of the actuator switching time was aborted due to an actuator timeout.
63/23 ... 63/28	Unit 1 ... Unit 6: Setting of upper/lower position feedback source incorrect.
63/29 ... 63/34	Unit 1 ... Unit 6: Setting of upper/lower position feedback source automatically changed.

Table 18: Description of the error code

28 DISASSEMBLY

28.1 Safety instructions



DANGER

Risk of injury due to high pressure and escaping medium.

- ▶ Secure the actuators against shifting before working on the device or plant.

Switch off the pressure before working on the device or plant. Vent or empty the lines.



WARNING

Risk of injury from electric shock.

- ▶ Switch off the power supply before working on the device or system. Secure against reactivation.
- ▶ Observe any applicable accident prevention and safety regulations for electrical devices.

Risk of injury due to improper removal!

- ▶ Disassembly should be performed only by trained personnel using suitable tools!

→ Loosen pneumatic connection.

→ Disconnect the electrical connection.

29 ACCESSORIES



CAUTION

Risk of injury and/or damage to property due to incorrect parts!

Incorrect accessories and unsuitable spare parts may cause personal injuries and damage to the device and the area around it.

► Use only original accessories and original spare parts from Bürkert.

Electronic modules

Article	Order no.
Electronic module	384873
Electronic module with digital inputs	384872

Connection modules

Article	Size	Order no.
Connection module		384866
Connection module with compressed air supply	D6, D10	384863
	D1/4, D3/8	384864
Connection module with pressure sensor	D6, D10	384867
	D1/4, D3/8	384868

Electrical accessories

Article	Quantity [unit]	Order no.
Termination resistor, M12 male	1	772424
Termination resistor, M12 female	1	772425
Gender changer, M12, male-male	1	772867
Y-distributor	1	772420
Y-distributor with interrupt	1	772421

Attachment accessories

Article	Quantity [unit]	Order no.
Screw set M5x10 A2 DIN 6912 (for attaching the valve island to the base of the control cabinet)	10	308661
Holding plate (for control cabinet exterior)	4-fold	60005571
	8-fold	60005566
	12-fold	60005567
	16-fold	60005568
	20-fold	60005569
	24-fold	60005570

bÜS accessories

Article	Quantity	Order no.
USB-bÜS-Interface set 1 (including power supply unit, bÜS stick, terminating resistor, Y-distributor, 0.7 m cable with M12 plug)		772426
USB-bÜS-Interface set 2 (including bÜS stick, terminating resistor, Y-distributor, 0.7 m cable with M12 plug)		772551
bÜS cable, angled M12 (stranded wire to female connector)	0.7 m	772626
bÜS cable (stranded wire to M12 female connector)	1.0 m	772409
	3.0 m	772410
	5.0 m	772411
	10.0 m	772412
bÜS cable drum	50.0 m	772413
	100.0 m	772414
bÜS extension cable	0.1 m	772492
	0.2 m	772402
	0.5 m	772403
	1.0 m	772404
	3.0 m	772405
	5.0 m	772406
	10.0 m	772407
	20.0 m	772408
bÜS service cable M12 to micro USB		773254
Adapter spring-loaded terminal to M12 (5-pole)	0,1 m	584765

Pneumatic accessories

Article	Quantity	Order no.	
Filter set for auxiliary pilot air	2 units	368590	
Push-in connector, straight	Brass, nickel-plated	M7 Ø 6 mm	773459
		M7 Ø 1/4"	773460
		G1/4" Ø 10mm	773461
		G1/4" Ø 3/8"	773462
	Stainless steel	M7 Ø 6 mm	773463
		M7 Ø 1/4"	773464
		G1/4" Ø 10 mm	773465
		G1/4" Ø 3/8"	773466

Article			Quantity	Order no.
Plastic hoses for pneumatic system, polyamide (PA)	Ø 6/4 mm	Blue	50 m	780643
		Black		780644
		Natural		780645
	Ø 8/6 mm	Blue		780646
		Black		780647
		Natural		780648
	Ø 10/8 mm	Blue		780649
		Black		780650
		Natural		780651
	Ø 6/4 mm	Blue	100 m	771868
		Black		771295
		Natural		771296
	Ø 8/6 mm	Blue		771869
		Black		771873
		Natural		771297
Ø 10/8 mm	Blue	771870		
	Black	771877		
	Natural	771874		
Push-in silencer	Ø 6 mm	Sintered bronze, brass nickel-plated body	1 unit	784306
	Ø 8 mm			784304
	Ø 10 mm			784305
	Ø 6 mm	Polyethylene (PE)		772571
	Ø 8 mm			773231
	Ø 10 mm			773522
	1/4"			773545
	3/8"			773546
Sealing plug	Brass, nickel-plated	08/06-08/06	1 unit	781666
		10/08-10/08		781667
	POM	06/04-06/04		782399
		08/06-08/06		782400
		10/08-10/08, red		782401
	PBTP	6 mm		771605
		8 mm		771606
		10 mm		771607

Other accessories

Article	Quantity [unit]	Order no.
Device marker set	40 (4 rakes)	368588
Additional element "Lock Manual Override"	8	328082
Micro SD card		774087

30 PACKAGING AND TRANSPORT

CAUTION

Risk of injury due to heavy device.

During transportation or installation work, a heavy device may fall down and cause injuries.

- ▶ Heavy equipment must only be transported, assembled and disassembled with the help of a second person.
- ▶ Use suitable tools.

CAUTION

Damage in transit due to inadequately protected devices.

- ▶ Protect the device against moisture and dirt in shock-resistant packaging during transportation.
- ▶ Observe permitted storage temperature.

31 STORAGE

CAUTION

Incorrect storage may damage the device.

- ▶ Store the device in a dry and dust-free location.
- ▶ Storage temperature $-10\dots+60$ °C.

32 ENVIRONMENTALLY FRIENDLY DISPOSAL



- ▶ Follow national regulations regarding disposal and the environment.
- ▶ Collect electrical and electronic devices separately and dispose of them as special waste.

Further information country.burkert.com.