



GEA Hilge

durietta I Bloc

Installation and operating instructions English

Translation of the original operating manual

BA.017.BYY.001.01.10.GB

Declaration of conformity

Declaration of conformity as per EC Directive 2006/42/EC, Appendix II A

The declaration refers to complete pump units (with and without motor).

We,

HILGE GmbH & Co. KG
Hilgestraße 37-47
D-55294 Bodenheim

hereby declare that the complete machine

- Type: durietta I
- Design: Bloc, Bloc-SUPER

is in compliance with the following requirements:

- Directive 2006/42/EC
(Machine Directive, Appendix II A)
- Directive 2004/108/EC
(EMC Directive)

Harmonised standards employed:

- DIN EN ISO 12100-1, Safety of machines; basic terms, general principles of design – Part 1: Basic terminology
- DIN EN ISO 12100-2, Safety of machines; basic terms, general principles of design – Part 2: Basic technical principles
- EN 809 / A1, Pumps and pump units for liquids
- DIN EN 60204-1, Safety of machines – electrical equipment of machines

The signatory is authorised to compile the documentation.

Bodenheim, January 1, 2010



Dr. Boris Kneip, Director of Design

1. Introduction	5
1.1 Target group	5
1.2 Symbols and formatting	5
1.3 References to the document	5
2. Safety	6
2.1 Instructions for the operator	6
2.1.1 General information	6
2.2 Safety instructions in the operating manual	6
2.3 Identification of instructions in the operating manual	7
2.3.1 Structure of safety instructions	7
2.4 Qualifications and training of personnel	8
2.5 Hazards caused by failure to follow the safety instructions	8
2.6 Safety-conscious work	8
2.7 Safety instructions for the operator / user	8
2.8 Unauthorized modifications and production of spare parts	9
2.9 Improper operation	9
2.10 Transport	10
2.11 Cleaning	10
2.12 Repair contract	11
3. Product description	12
3.1 Pump overview	12
3.2 Description	12
3.2.1 Areas of application	12
3.3 Proper usage	13
3.3.1 Pumped liquids	13
3.3.2 Minimum flow rate Q_{min}	13
3.3.3 Connections and pipelines	13
3.3.4 Motor activation	13
3.3.5 Design	13
3.4 Technical data	13
3.4.1 Pump denomination	14
3.4.2 Pump serial number	14
3.4.3 Nameplate	14
3.4.4 Performance data	14
3.4.5 Weights	15
3.4.6 Noise emissions	15
3.4.7 Maximum operating temperature	16
3.4.8 Maximum operating pressure	16
4. Mounting, installation and connection	17
4.1 Inspection before pump installation	17
4.1.1 Check failure-free running of the impeller	17
4.2 Set-up and alignment of the pump assembly	17
4.3 Installation in the pipeline	18
4.3.1 Space requirements	21
4.3.2 Reduction of noise and vibration	22
4.4 Electrical connections	23
4.4.1 Star connection	23
4.4.2 Delta connection	23
4.4.3 Checking the direction of rotation after connection	24
5. Start-up / shut-down	25

5.1 Start-up	25
5.1.1 Check application conditions	25
5.1.2 Starting up the pump	25
5.1.3 Functional check of the mechanical seal	25
5.1.4 Shut-down	26
5.1.4.1 Shutting down the pump	26
5.1.5 Cleaning the pump after shut-down	26

6. Maintenance / servicing **27**

6.1 Safety instructions for maintenance, inspection and installation work	27
6.2 Maintenance of the pump	28
6.3 Maintenance of the motor	28
6.4 Assembly	29
6.4.1 Parts overview	29
6.4.2 Instructions for disassembly	30
6.4.3 Instructions for assembly	30
6.4.4 Disassembly of the pump	31
6.4.5 Assembly of the pump	33
6.5 Troubleshooting	37
6.6 Disposal	38
6.7 HILGE assembly tool kit	39
6.7.1 Content and use	39

7. Certificate of non-objection **42**

7.1 Certificate of non-objection	42
----------------------------------	----

1. Introduction

Abstract

This section describes the requirements which are important for reading and understanding this manual. You will learn the symbols and formats that make the reading easier.

1.1 Target group

This operating manual is intended for:

- the operators of the pump
- maintenance and repair personnel.

It is assumed that all such personnel will have the basic technical background required for the start-up, maintenance, and repair of pump systems.

Sections aimed only for specially authorised personnel are indicated by a preceding notation to this effect.

1.2 Symbols and formatting

The following symbols and formats are intended to make it easier to read this document:

- Listed items

Instructions

Instructions that must be carried out in a specific sequence are numbered in the corresponding order.



Important information and helpful tips are identified with the index finger symbol.

Safety instructions

The system used to identify safety instructions is described in section 2.3, page 7.

1.3 References to the document

Copyright

This document may not be copied, translated into other languages, or made available to third parties without our explicit written approval.

Technical changes

Design variants, technical data, and spare part numbers are subject to technical change.

The right to make changes for the sake of further technical development is reserved.

2. Safety

Abstract

This section describes what you have to consider for your own safety. You will learn the structure and identification of safety instructions. Read this important section attentively!

2.1 Instructions for the operator

2.1.1 General information

All our pumps are professionally packed before they leave our warehouse to avoid damage during transport.

Unpacking If, after carefully unpacking and inspecting the shipment, you however find damage, you must promptly inform the shipping agent (railway, post office, lorry driver, shipping line, etc.).

Your claim should be filed with the shipping agent. The shipping risk passes to the customer as soon as the shipment leaves our warehouse.

Storage If the pump is not put into service immediately, it is important that it is stored properly to ensure that it will function correctly later. This is just as important as proper installation and maintenance.

The pump must be protected from cold, moisture, and dust as well as from mechanical influences.

Specially trained personnel is required to install and maintain the pump properly.

2.2 Safety instructions in the operating manual

Read safety instructions! The operating manual contains all the basic information required for the set-up, operation, and maintenance of the pump. The installer as well as the technical personnel or operator responsible for the pump must therefore read this manual before installing and starting the pump. The operating manual must always be available at the site where the machine/system is being used. Not only the general safety instructions presented in this section but also the specific safety instructions in later sections must be followed.

Safety

2.3 Identification of instructions in the operating manual

Symbol The safety instructions presented in this operating manual are identified as shown below.

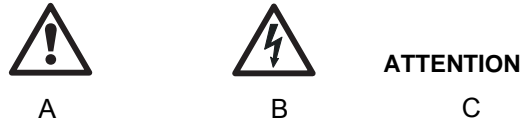

Fig. 1 Symbol for safety instructions

K.0319V1 | K.0320V1

- A: Failure to follow these safety instructions can endanger personnel.
- B: Safety instructions which involve warnings against electrical voltage.
- C: Failure to follow these safety instructions can endanger the machine and its operation.

Signal words In order to classify the safety labels they are distinguished by the following signal words:



- **Danger**
Characterises an imminent hazard with a high risk which can cause death or grievous bodily harm.
- **Warning**
Characterises a possible hazard with medium risk which can cause death or bodily harm if it is not avoided.
- **Caution**
Characterises a hazard with minor risk which can causes minor or medium bodily harm if it is not avoided.

Don't remove instructions from machine

Instructions attached directly to the machine, such as rotational direction arrow must be noted and kept in completely legible condition.

Damaged or illegible instructions must be replaced.

2.3.1 Structure of safety instructions

<p>Warning</p> 	<p>Description of danger!</p> <ul style="list-style-type: none"> ▲ Possible consequence. ▷ Action to eliminate the danger.
<p>Example:</p>	
<p>Danger</p> 	<p>Electrical shock if electrical parts are touched!</p> <ul style="list-style-type: none"> ▲ Death, serious bodily injury, damage to property. ▷ Before attempting to diagnose any fault, make sure that the main switch has been switched off. It must be ensured that the electricity supply cannot be accidentally switched on.

2.4 Qualifications and training of personnel

The employees operating, maintaining, inspecting, and installing the pump must have the appropriate qualifications for this work. The operator must define in detail the tasks for which the employees are responsible, the tasks of which they are in charge, and the manner in which they are supervised.

If the employees do not have the necessary knowledge, they must be instructed and trained accordingly. This can be done, if necessary, by the manufacturer/supplier under contract to the operator. The operator must also guarantee that the employees fully understand the contents of the operating manual.

2.5 Hazards caused by failure to follow the safety instructions

If these safety instructions are not followed employees, the machine itself and the environment will be in danger.

Failure to follow the safety instructions can lead to the loss of the right to file claims for damages.



Failure to follow instructions can, for example, lead in particular to the following hazards:

- Breakdown of important functions of the machine/system
- Failure of recommended methods of maintenance and repair
- Endangerment of personnel by electrical, mechanical, and chemical hazards
- Endangerment of the environment by leakage of hazardous materials.

2.6 Safety-conscious work

The safety instructions given in this operating manual, the existing national regulations for accident prevention, and any applicable internal working, operating, and safety instructions of the operator must be followed.

2.7 Safety instructions for the operator / user

<p>Caution</p> 	<p>Hot or cold mechanical components!</p> <p>▲ Serious bodily injury.</p> <p>▷ Take structural measures to prevent contact with them!</p>
<p>Warning</p> 	<p>Trapping hazard!</p> <p>▲ Death, serious bodily injury, damage to property.</p> <p>▷ Do not remove protection against contact with moving parts (e.g. coupling guard) while the machine is operating.</p> <p>▷ Replace defective safety equipment immediately.</p>

Safety

Warning



Contact with hazard substances (e. g. inhale)!

- ▲ Death, serious bodily injury, damage to property.
 - ▷ Drain away leakage of hazardous pumping media in such a way that there is no danger to personnel or to the environment.
 - ▷ Follow legal regulations.
 - ▷ If shaft seal fails switch off the pump. Replace seal before next start-up.
-

Caution



Tripping hazard from electric power cable!

- ▲ Death, serious bodily injury.
 - ▷ Route the electric power cable in such a way that no one can trip over it (in case of portable pumps).
-

Warning



Electrical hazard!

- ▲ Death, serious bodily injury.
 - ▷ Only use acceptable electric cables and plugs.
-

2.8 Unauthorized modifications and production of spare parts

No modifications or changes to the machine may be made without written approval of the manufacturer. In the interest of safety, only original spare parts and accessories authorized by the manufacturer may be used. The use of other parts can exempt the manufacturer from liability for damage which may thus be caused.

2.9 Improper operation

The operational reliability of the delivered machine can be guaranteed only when it is used properly as indicated in the following sections.



The given limit values may not be exceeded under any circumstances.

2.10 Transport

Warning



Falling loads!

- ▲ Death, serious bodily injury, damage to property.
 - ▷ Transport work must only be performed by persons qualified to do so, and all safety instructions must be observed.
 - ▷ Use suitable load carrying equipment with sufficient capacity to transport the pump.
 - ▷ Make certain there are no persons under the suspended load.
 - ▷ Make certain the pump is aligned horizontally when it is lifted.
-

ATTENTION

Incorrect lifting points!

- ▲ Damage to property.
 - ▷ Fasten the rope to suitable lifting points.
 - ▷ Never fasten a rope to the pump casing or intake/discharge branch.
 - ▷ In case of SUPER design¹: Remove shroud before transporting.
-

2.11 Cleaning

CIP and SIP methods must be in accordance with the latest current guidelines of the EC.

When special cleaning agents and methods are used, the supplier must confirm that they are safe for the materials involved.

Warning



Pressure surge!

- ▲ Death, serious bodily injury, damage to property.
 - ▷ Before sterilisation always evacuate the system completely!
-

1. Option.

Safety

2.12 Repair contract

The duty to follow the legal regulations on work safety and the regulations on environmental protection means that all commercial enterprises must protect their employees, the public at large, and the environment from the harmful effects of hazardous materials.

Examples of legal regulations on work safety:

- the Workplace Act (ArbStättV)
- the Hazardous Materials Act (GefStoffV)
- the accident prevention regulations(BGV A1)
- and all applicable laws, rules, guidelines, regulations etc. in the country of operation.

Examples of regulations on environmental protection:

- the Recycling and Waste Law (KrW/AbfG)
- the Water Economy Law (WHG)
- and all applicable laws, rules, guidelines, regulations etc. in the country of operation.

Certificate of non-objection

The certificate of non-objection attached to the shipment is a component of the inspection/repair contract. This does not affect our right to refuse acceptance of this contract for other reasons.

The certificate of non-objection can be found on page 42.

HILGE products and their parts will only be inspected/repaired if the certificate of non-objection is present and has been correctly completed by authorized and qualified technical personnel.

Pumps which have been operated in media exposed to radiation will not be accepted.

If any additional safety measures are required even after the careful draining and cleaning of the pump, the necessary information must be provided.

3. Product description

Abstract

This section describes the pump as well as its design and application. This section describes limits for application. You must know and keep these limits.

3.1 Pump overview

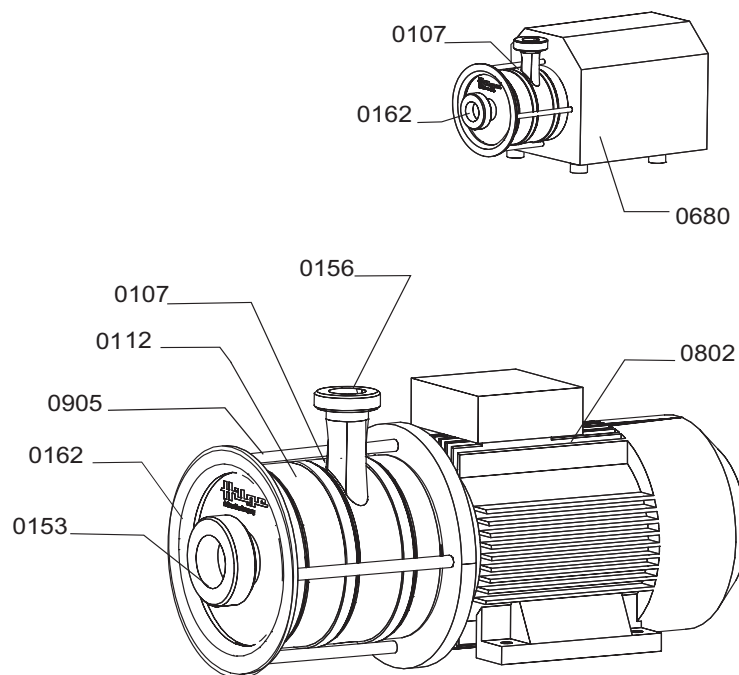

K.0378V2

Fig. 2 Parts overview

- 0107 discharge casing
- 0112 diffuser casing
- 0153 suction branch
- 0156 discharge branch
- 0162 suction cover
- 0680 shroud
- 0802 close coupled motor
- 0905 tie bolt

3.2 Description

The pump is a single- or multi-stage centrifugal pump of end-suction type with a modular design.

3.2.1 Areas of application

Standard design Pumps of the standard design are used for:

- industrial application
- textile technology
- all systems and processes involved in the food product, dairy, and beverage industries.

Product description

3.3 Proper usage

Warning**Improper usage!**

- ▲ Death, serious bodily injury, damage to property.
 - ▷ Pump only media that are specified in the order. The pump has been specially designed for that purpose.
 - ▷ Operate the pump only in the electrical network specified in the order.
-

3.3.1 Pumped liquids

Only pure or slightly contaminated liquids with a maximum particle size of 0.4 mm may be pumped. These liquids may not chemically or mechanically attack the pump materials or lower their strength. If liquids with a viscosity greater than that of water are to be pumped, make sure that the motor will not be overloaded. The pump may not be operated beyond the maximum allowable values. Even short periods of pressure overload (e.g., as a result of a pressure surge) should be avoided.

3.3.2 Minimum flow rate Q_{\min}

Do not operate the pump below minimum flow rate of $Q_{\min} = 10 - 15 \% Q_{\text{opt}}$.

3.3.3 Connections and pipelines

The nominal diameters of the system pipelines should be equal to or greater than the nominal diameters of the pump, i.e., DNE (suction side) and DNA (pressure side), and the connecting elements to the pump must conform exactly to the design standard/specification of the mating connector piece installed on the pump. The suction line must be absolutely leak-tight and laid in such a way that no air pockets can form. Avoid tight elbows and do not install valves immediately upstream of the pump. The suction head of the system may not be greater than the suction head guaranteed by the pump.

3.3.4 Motor activation

Do not start and stop the motor more than 15 times per hour.

3.3.5 Design

All information and descriptions in this operating manual concerning the use and operation of the pumps are based exclusively on the standard designs.

These rules do not apply to special designs, to customer specific modifications, or to random external influences which may occur during use and operation.

3.4 Technical data

Warning**Overloading the pump!**

- ▲ Death, serious bodily injury, damage to property.
 - ▷ Use the pump only under the indicated operating conditions.
 - ▷ Also avoid short over pressure situation (e.g. caused by pressure surge).
-

3.4.1 Pump denomination

The HILGE pump denomination is structured as shown below:

durietta I	211	BYY	32/25	3	2
pump type					
stages / impeller index					
design					
nominal diameter DN _s / DN _D					
power [kW]					
number of poles					

Tab. 1 HILGE pump denomination (example)

3.4.2 Pump serial number

The pump can be identified by the pump serial number. When ordering spare parts always state the pump serial number.

Pump serial number (example) 017 / 09 / 1248

The pump serial number includes:

- pump type (017)
- year of manufacture (09)
- registration number (1248)

3.4.3 Nameplate

The nameplate contains the following data:

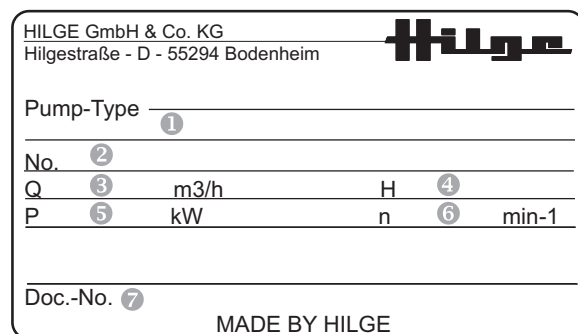

Fig. 3 HILGE nameplate, example

- 1 - pump type
- 2 - pump serial number
- 3 - capacity Q
- 4 - head H
- 5 - motor power P
- 6 - drive speed n
- 7 - number of operating manual

NOTE: The nameplate can deviate from the one shown.

3.4.4 Performance data

The performance data of the pump, namely, its head and delivery rate, are determined in accordance with DIN EN ISO 9906 - appendix A, class 2 and are documented on the acceptance records.

Product description

3.4.5 Weights

Design features of the described standard pumps:

Caution:

The weights can - depending on design and accessories - differ from those presented. The manufacturer gives you when given the pump / order number precise information.

- Motor foot mounting
- Single mechanical seal
- SIEMENS motor

	Stage	Motor power[kW]	Number of poles	Motor size	Weight [kg]
durietta I	1	0,25	4	080Y	21
	1	0,55	2	080Y	21
	1	0,75	2	080Y	22
	1	1,1	2	080Y	25
	1	2,2	2	090L	23
	2	2,2	2	100L	32
	2	3	2	100L	37
	3	3	2	100L	39

Table 2 Weights

3.4.6 Noise emissions

Measured values according to DIN EN ISO 3746 for pump units; uncertainty of measurement 3dB (A).

	Motor power kW	Number of poles	L _{pfa} [dB (A)]					
			1. Stage	2. Stage	3. Stage	4. Stage	5. Stage	6. Stage
durietta 0 / I	0,55	2	60	62	62	64	65	65
	0,75		61	61	64	65	67	69
	1,1		61	62	63	66	68	70
	1,5		62	62	64	66	68	71
	2,2		64	64	66	69	72	74
	3		67	68	70	74	75	76

Table 3 Noise emissions

	Motor power kW	Number of poles	L _{pfa} [dB (A)]					
			1. Stage	2. Stage	3. Stage	4. Stage	5. Stage	6. Stage
durietta 0 / I	0,25	4	50	50	51	51	52	53

Table 4 Noise emissions

Noise emissions caused by a pump are significantly affected by its application and construction. For this reason, no guarantee of accuracy is given for the values indicated here

3.4.7 Maximum operating temperature

Warning	Exceeding the max. permitted operating temperature!
	<p>▲ Death, serious bodily injury, damage to property.</p> <p>▷ Never exceed the specified operating temperatures.</p>

Design	Temp. [° C]
Standard design	95
Special design	150
Sterilization (SIP)	140

Tab. 5 Operating temperatures

3.4.8 Maximum operating pressure

Warning	Pressure overload!
	<p>▲ Death, serious bodily injury, damage to property.</p> <p>▷ The pump must be operated according to the order data.</p> <p>▷ Never exceed the specified maximum operating pressures.</p>

Pump operating pressure The maximum permitted operating pressure depends on various factors:

- pump type
- design of connections
- design of mechanical seal.

For the values that apply to your pump, please refer to the order documents.

4. Mounting, installation and connection

Abstract

This chapter is intended for the maintenance and repair personnel.

This section describes how to mount, adjust and install the pump. You get to know what to consider when you connect the pump to the electric mains supply and how to improve the flow in order to avoid dry running of the shaft seals.

4.1 Inspection before pump installation

4.1.1 Check failure-free running of the impeller

Check the failure-free impeller running in this way:

1. Remove motor shroud¹.
2. Remove fan cover of motor.
3. Consider direction of rotation (arrow).
4. Rotate shaft slowly by hand via the fan.

The shaft must rotate easily. If the impeller rubs against the pump casing (for example due to transport damage) it has been damaged.

When the impeller rubs against the casing: Contact HILGE Service.

When the impeller runs failure free:

5. Re-fit fan cover of the motor.
6. Re-fit motor shroud¹.

4.2 Set-up and alignment of the pump assembly

Warning



Misalignment of the pump due to an improper foundation!

- ▲ Death, serious bodily injury, damage to property.
 - ▷ Ensure that the foundation on which the pump is set up is clean and flat and has sufficient load capacity.
 - ▷ Mount the pump – especially when it is to be set up vertically – with the use of suitable heavy-duty anchors. As the centre of gravity is higher, the pump can tip.
 - ▷ The mounting points provided must be bolted to the foundation according to the standard rules of mechanical engineering to ensure the satisfactory set-up of the pump.
-

1. SUPER design only.

Mounting, installation and connection

Warning**Short circuit!**

- ▲ Death, serious bodily injury, damage to property.
 - ▷ In case of a vertical installation: Under no circumstances the motor should be positioned underneath the pump. If there is leakage the motor could be damaged.
-

Align the pump in this way:

1. Use an engineer's spirit level laid across the machined surface of the discharge branch connection to align the assembly.
2. After aligning the assembly, tighten the mounting bolts uniformly in a crosswise manner.

4.3 Installation in the pipeline

Warning**Mechanical overload!**

- ▲ Death, bodily injury or damage to property.
 - ▷ Do not use the pump or its connecting sleeves to support the pipeline. (EN809 5.2.1.2.3 and EN ISO 14847).
 - ▷ In addition to the general rules of machine-building and plant construction, also follow the instructions provided by the manufacturer of the connecting elements used (e.g., flanges) when installing the pump in the pipeline or plant. These specifications will contain data on torques, maximum allowable angular offset and tools / auxiliary materials to be used.
 - ▷ It is absolutely necessary to avoid twisting the pump.
-

ATTENTION**Mechanical overload due to foreign objects!**

- ▲ Damage to property.
 - ▷ The suction and delivery ports are sealed with sheets of plastic, the flushing and drain lines with plastic caps. These must be removed before the pump is installed in the system.
-

Details about dry running

What is dry running?

To seal the pump shaft against the pump casing the mechanical seal needs lubrication between its rotating faces.

This lubrication is provided by the pumped liquid. If the pump is fitted with a quench the lubrication for the quench must be provided from an external source.

Dry running occurs when the lubrication fails. Dry running destroys the mechanical seal in few seconds.

Mounting, installation and connection

For example see Fig. 4.

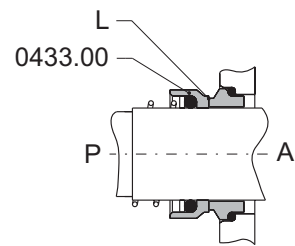

K.0075/2

Fig. 4 Lubrication between slide surfaces

- P - pump side
- 0433.00 - mechanical seal
- L - lubrication
- A - atmosphere side

Caution



Dry running!

▲ Damage to property.

- ▷ The suction line must be absolutely leak proof and laid in such a way that no air pockets can form.
- ▷ Avoid tight elbows and valves immediately upstream of the pump. They interfere with the incoming flow to the pump and thus with the NPSH of the system.
- ▷ The head of the system may not be greater than the head guaranteed by the pump.
- ▷ The head of the system may not be greater than the head guaranteed by the pump.
- ▷ The nominal pipeline diameters of the system should be equal to or greater than the DNS or DND connectors of the pump.
- ▷ A foot valve should be used in suction mode.
- ▷ To prevent air pockets from forming, the suction line must be laid so that it rises to the pump; a gravity feed line must be laid with a slight downward gradient to the pump.
- ▷ If local conditions do not allow the suction line to ascend continuously, install a venting device at the highest point of the line.
- ▷ A shut off valve should be installed in the suction line near the pump. This valve must be completely open during operation and may never be used as a control valve.
- ▷ A shut off valve should be installed in the discharge line, near the pump, to control the delivery rate.

Mounting, installation and connection

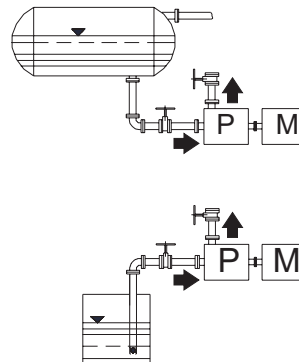

K.0076/2

Fig. 5 Installation in the pipeline

above: gravity feed mode

below: suction mode

P - pump

M - motor

Mounting, installation and connection

4.3.1 Space requirements

ATTENTION**Overheating!**

- ▲ Damage to property.
 - ▷ Ensure sufficient ventilation.
 - ▷ Make sure not to re absorb warm cooling air. Consider other heat sources in the area.
-

Pay attention to motor power. Keep the minimum distances.

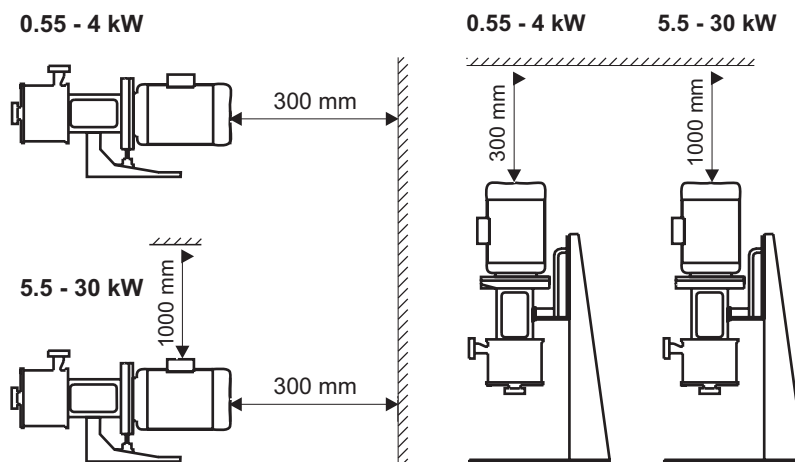

K.0317V1

Fig. 6 Minimum distances

Mounting, installation and connection

4.3.2 Reduction of noise and vibration

Noise and vibration are generated by the pulsating flow of the rotors and by the flow in pipes and fittings. The effect on the environment is subjective and depends on correct installation and the state of the remaining system. One way of reducing noise and vibrations is by installing expansion joints.

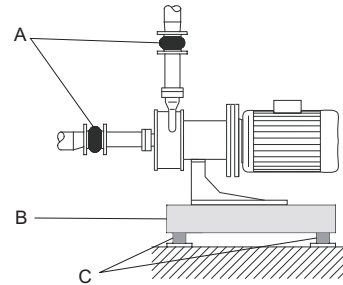

K.0346V1

Fig. 7 Expansion

- A - Expansion joints
- B - Foundation
- C - vibration absorber

Function of expansion joints:

- Absorbability of expansions/contractions in the pipework caused by changing the temperature of the pumped medium.
- Reduction of mechanical strains in connection with pressure surges in the pipework.
- Insulation of mechanical structure-borne noise in the pipework (only rubber bellows expansion joints).



Do not install expansion joints to compensate for inaccuracies in the pipework such as centre displacement of flanges. Fit expansion joints at a distance of minimum 1 to 1½ times the nominal flange diameter away from the pump on the suction as well as on the discharge side. This will prevent the development of turbulence in the expansion joints, resulting in better suction conditions and a minimum pressure loss on the pressure side. At high viscosity or velocities, we recommend you to install larger expansion joints corresponding to the pipework.

Mounting, installation and connection

4.4 Electrical connections

Warning



Electric shock!

- ▲ Death, serious bodily injury.
- ▷ The electrical connections must be made by a qualified electrician.
- ▷ VDE specifications and any local regulations must be followed, especially those pertaining to safety measures.

Warning



Capacity overload!

- ▲ Death, serious bodily injury, damage to property.
- ▷ Check the voltage stated on the rating plate of the motor against the operating voltage!
- ▷ Install an electrical circuit breaker.

4.4.1 Star connection

Star-connection 3-phase system for high voltage.

Connect the pump as specified in the order documents. The figure below shows the scheme for star connection.

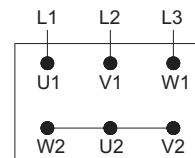

K.0079V1

Fig. 8 Star connection

4.4.2 Delta connection

Delta-connection for low voltage.

Connect the pump as specified in the order documents. The figure below shows the scheme for delta-connection.

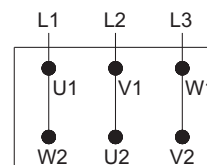

K.0080V1

Fig. 9 Delta connection

Mounting, installation and connection

4.4.3 Checking the direction of rotation after connection

ATTENTION**Danger of dry running!**

- ▲ Damage to property.
 - ▷ Before checking of the direction of rotation: Fill and vent the pump.
 - ▷ Connect the motor and briefly (for about 2 seconds) check the direction of rotation.
Note the directional arrow (red) on the pump. If the pump is turning in the wrong direction the mechanical seal can be destroyed.
-

Check the rotating direction in this way:

1. After electrical connection: Mount all safety equipment again.
2. Check tightness of hydraulic connection.
3. Fill pump (plant).
4. Observe arrow of rotation.
5. Switch on motor short-time (1-2 seconds).
6. Compare directions (motor / arrow).
7. Correct connection if need be.

Operation with frequency inverter

See documentation of manufacturer.

5. Start-up / shut-down

Abstract

This section describes how to start up and shut down the pump. You get to know which inspections contribute to failure-free operation and increased life of the pump.

5.1 Start-up

5.1.1 Check application conditions

Check the application conditions of the pump in this way:

1. Compare the data of the following documents with the provided application condition of the pump:
 - purchasing documents (confirmation of the order)
 - nameplate
 - operating manual.
2. Make sure that the pump will operate under the mentioned conditions only. These conditions apply to (e. g.) pressure, temperature, liquid pumped.

5.1.2 Starting up the pump

Start up the pump in this way:

1. Check tightness of connection.
2. Make sure that all safety equipment is installed.
3. Make sure that all electrical connections are correct.
4. Open the check valves in the system.
5. Fill the pump together with the system.
6. Vent the pump and system.
7. Fully open the check valve on the suction side.
8. Close the check valve on the discharge side.
9. Start the pump.
10. Slowly open the check valve on discharge side.

Caution



Overheating and pressure overloading!

- ▲ Damage to property.
 - ▷ Never operate the pump against a closed shut-off device. Operation with a shut-off device must on no account continue for longer than 30 seconds.
-

5.1.3 Functional check of the mechanical seal

If delivery head does not rise after the pump has been turned on:

1. Switch off the pump.
2. Vent the pump (system) again.
3. Repeat steps 7., page 25 to 10., page 25.

Check the function of the mechanical seal in this way:

1. Watch the pump and check the mechanical seal for flawless functioning (leak test).
An intact mechanical seal works virtually without leakage.

If liquid pumped or flushing liquid leak:

1. Switch off the pump.
2. Renew the mechanical seal.
Observe section 6.1, page 27

5.1.4 Shut-down

5.1.4.1 Shutting down the pump

Caution**Pressure surge!**

- ▲ Death, serious bodily injury, damage to property.
 - ▷ Always close shut-off devices slowly!
-

What is a pressure surge?

A pressure surge is an abruptly pressure increasing in the system. This pressure increasing can - for example - be caused by a quick blocking of the flow in the discharge pipe. In case of a pressure surge the maximum permitted pump pressure is temporarily exceeded manifold.

Shut down the pump in this way:

1. Close the check valve on the discharge side.
2. Switch off the pump.
3. Close the check valve on the suction side.
4. Make sure that the pump is depressurised.
5. Switch off pressure in barrier system¹.

5.1.5 Cleaning the pump after shut-down

Caution**Jamming!**

- ▲ Damage to property.
 - ▷ Clean the pump appropriately after shut down.
-

See 2.11, page 10 (Cleaning)

1. only for back-to-back arrangement

6. Maintenance / servicing

Abstract

This chapter is intended for the maintenance and repair personnel.

This section gives important information concerning maintenance and servicing of the pump. Read this section before you carry out maintenance work or troubleshooting measures!

6.1 Safety instructions for maintenance, inspection and installation work

Warning



Unprofessional work!

- ▲ Death, bodily injury, damage to property.
 - ▷ The operator must ensure that all maintenance, inspection, and installation work is carried out by authorised and qualified technical personnel, who have acquired the required knowledge through study of the operating instructions.
-

Danger



Electrical shock if electrical parts are touched!

- ▲ Death, bodily injury.
 - ▷ Always turn off the electrical supply at the pump before eliminating any breakdown.
-

Warning



Pressurized spray!

- ▲ Death, bodily injury, damage to property.
 - ▷ Depressurize the pump before eliminating any breakdown.
-

Warning



Hot components!

- ▲ Death, bodily injury, damage to property.
 - ▷ Always allow to cool down before eliminating any breakdown.
-

Warning



Unintentioned switching on the pump!

- ▲ Death, bodily injury, damage to property.
 - ▷ Take appropriate measures to ensure that the machine cannot be unintentionally turned on again.
-

Warning**Contact or inhaling of hazardous substances!**

- ▲ Death, bodily injury, damage to property.
 - ▷ Pumps or systems which convey hazardous media must be decontaminated.
-

Warning**Missing protection and safety equipment!**

- ▲ Death, bodily injury, damage to property.
 - ▷ Immediately after completing the work install the protection and safety equipment and make sure it functions.
-

Caution**Improper tools!**

- ▲ Damage to property.
 - ▷ In accordance with the design standard (3A0.01 to 3A3.37), all tools, possible support surfaces, and other auxiliary materials must ensure that all parts of the pump can be assembled without damage (e.g. scratches). See ("HILGE assembly tool kit" on page 39).
-

Caution**Frost!**

- ▲ Damage to property.
 - ▷ When there is danger of frost drain the pump completely.
-

6.2 Maintenance of the pump

The pump is a low-maintenance pump. In addition to cleaning, the only point to be kept in mind is the wear to the rotating mechanical seal.

6.3 Maintenance of the motor

See operating manual of the motor manufacturer.

6.4 Assembly

6.4.1 Parts overview

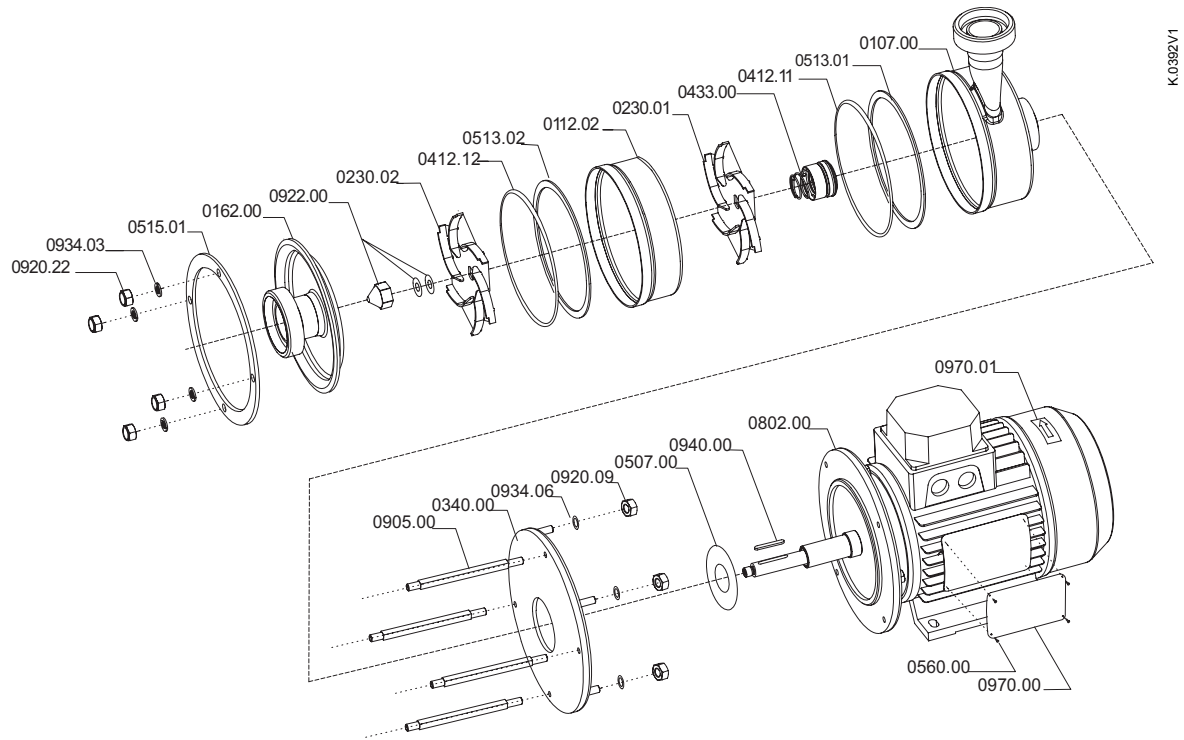

Fig. 10 Parts overview

Pce.	Part no.	Designation
1	0107.00	discharge casing
1	0112.02	diffusor casing
1	0162.00	suction cover
1	0230.01	impeller
1	0230.02	impeller
1	0340.00	lantern
1	0412.11	O-ring ^a
1	0412.12	O-ring
1	0433.00	mechanical seal
1	0507.00	deflector / V-ring
1	0513.01	insert ring
1	0513.02	insert ring

Pce.	Part no.	Designation
1	0515.01	clamp ring
4	0560.00	pin
1	0802.00	close coupled motor
4	0905.00	tie bolt
4	0920.09	hexagon nut
4	0920.22	hexagon nut
1	0922.00	impeller nut
4	0934.03	spring washer
4	0934.06	spring washer
1	0940.00	key
1	0970.00	name plate
1	0970.01	sense of rotation arrow

Table 6 Parts list

a. Parts which are depending on number of stages are partially without figure.

6.4.2 Instructions for disassembly

Danger**Disregarding important instructions!**

- ▲ Death, serious bodily injury, damage to property.
 - ▷ Before you disassemble the pump note chapter 6.1, page 27.
-

ATTENTION**Important aspects!**

- ▲ Damage to property.
 - ▷ Use tools from HILGE assembly tool kit in order to disassemble the pump without damage and scratches.
-

6.4.3 Instructions for assembly

Danger**Disregarding important instructions!**

- ▲ Death, serious bodily injury, damage to property.
 - ▷ Before you maintenance or assemble the pump note section 6.1, page 27.
-

Important aspects!

- ▷ Use tools from HILGE assembly tool kit in order to assemble the pump without damages and scratches.
- ▷ To guarantee a good seal, use only O-ring seals with the original dimensions.
- ▷ Never use grease which contains mineral oil when assembling the wet end parts¹.
- ▷ Replace mechanical seals always in complete assembly.
- ▷ To tighten impeller nut 0922.00, use either a screw device or the impeller nut installing device because the torque applied to tighten must be absolutely concentric. Otherwise there is the danger that the pump shaft 0211.00 will be bent.

1. Parts which come in contact with the pumped medium.

Maintenance / servicing

6.4.4 Disassembly of the pump

Disassemble the pump in this way:

-
1. Unscrew and remove hexagon nuts 0920.22 and spring washers 0934.03.

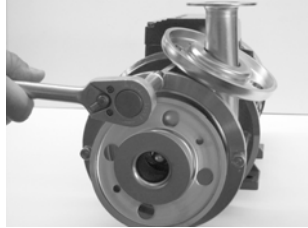

Fig. 11 Clamp ring fixing

2. Remove clamp ring 0515.01.

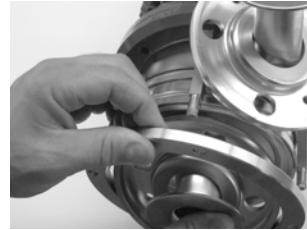

Fig. 12 Clamp ring

-
3. Remove suction cover 0162.00.



Fig. 13 Suction cover

4. Remove O-ring 0412.12.



Fig. 14 O-ring

-
5. Remove insert ring 0513.02.



Fig. 15 Insert ring

6. Unscrew impeller nut 0922.00.



Fig. 16 Impeller nut

-
7. Remove impeller 0230.02.



Fig. 17 Impeller

8. Remove diffusor casing 0112.02.



Fig. 18 Diffusor casing

-
9. Remove insert ring 0513.01 together with O-ring 0412.11.

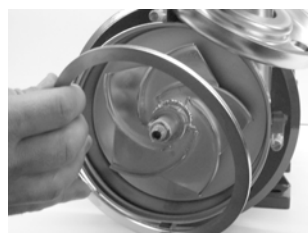

Fig. 19 Insert ring

10. Remove impeller 0230.01.
Repeat step 8 to 10 for further stages.



Fig. 20 Impeller

11. Remove key 0940.00.



Fig. 21 Key

12. Remove rotary ring of mechanical seal 0433.00.



Fig. 22 Rotary ring of the mechanical seal

13. Remove stationary ring of mechanical seal 0433.00.



Fig. 23 Stationary ring of the mechanical seal

14. Unscrew and remove hexagon nuts 0920.09 and washers 0934.06.

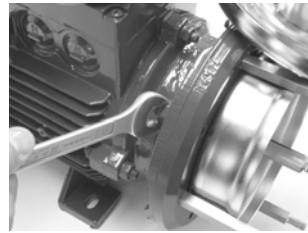

Fig. 24 Hexagon nut

15. Remove lantern 0340.00.

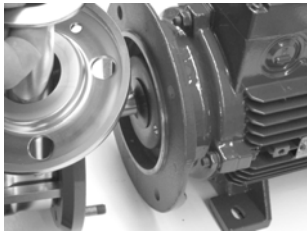

Fig. 25 Close coupled motor

16. Remove deflector 0507.00.

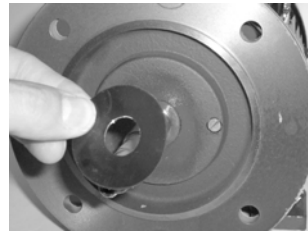

Fig. 26 Deflector

17. Remove discharge casing 0107.00.

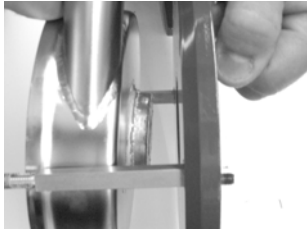

Fig. 27 Discharge casing

18. Unscrew and remove tie bolts 0905.00.

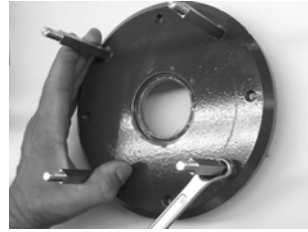

Fig. 28 Lantern

Maintenance / servicing

6.4.5 Assembly of the pump

Assemble the pump in this way:

1. Screw the tie bolts 0905.00 into the lantern 0340.00.

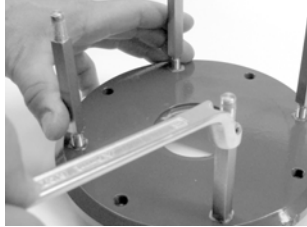

Fig. 29 Tie bolts

2. Push deflector / V-ring 0507.00 onto the motor shaft up to the stop.



Fig. 30 Deflector

3. Assemble lantern 0340.00.



Fig. 31 Lantern

4. Fix lantern 0340.00. Use hexagon nuts 0920.09 and spring washers 0934.06 to do this.

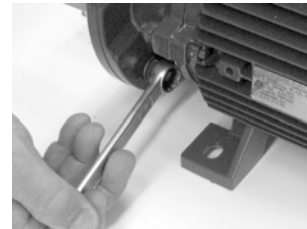

Fig. 32 Hexagon nut

5. Grease the seat of discharge casing 0107.00. Use Klüberpaste UH1 96-402 from Hilge assembly tool kit (pos. 6, Fig. 55).
6. Assemble discharge casing 0107.00.

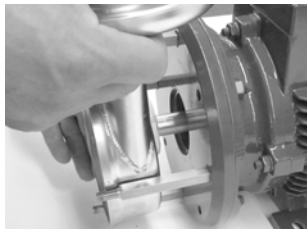

Fig. 33 Discharge casing

7. Adjust discharge casing 0107.00 via discharge branch by using a spirit level.

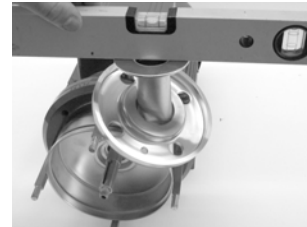

Fig. 34 Discharge branch

8. Slide assembly sleeve from Hilge assembly tool kit (pos. 3, Fig. 55) onto pump shaft.



Fig. 35 Assembly sleeve

9. Spray pump shaft with clean water.
10. Use spray bottle from Hilge assembly tool kit (pos. 2, Fig. 55).



Fig. 36 Mechanical seal

-
11. Push the stationary ring of the mechanical seal 0433.00 into the seat of discharge casing 0107.00.
Use installation sleeve from Hilge assembly tool kit (pos. 12, Fig. 55).



Fig. 37 Mechanical seal

12. Slide rotary ring of the mechanical seal 0433.00 onto the pump shaft.
Use installation sleeve from Hilge assembly tool kit (pos. 12, Fig. 55).



Fig. 38 Mechanical seal

-
14. Insert key 0940.00 into pump shaft.



Fig. 39 Key

13. Remove assembly sleeve from pump shaft.

15. Unload the spring of the mechanical seal 0433.00.



Fig. 40 Mechanical seal

-
16. Grease the pump shaft.
Use Klüberpaste UH1 96-402 from Hilge assembly tool kit (pos. 6, Fig. 55).
17. Assemble impeller 0230.01.



Fig. 41 Impeller

18. Assemble insert ring 0513.01 and O-ring 0412.11.

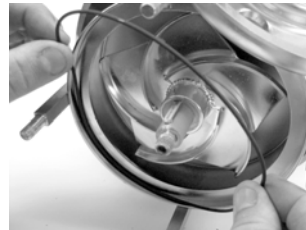

Fig. 42 O-ring

-
19. Assemble insert ring 0513.02 and O-ring 0412.12 into diffusor casing 0112.02.



Fig. 43 Insert ring

20. Assemble diffusor casing 0112.02.



Fig. 44 Diffusor casing

Maintenance / servicing

21. Assemble impeller 0230.02.
22. Repeat steps 19 - 21 depending on numbers of pump stages.

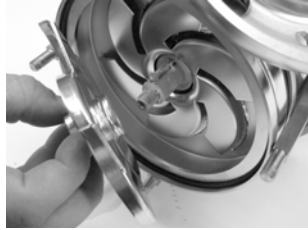

Fig. 45 Impeller

23. Grease Nord-Lock washer 0922.00. Use Klüberpaste UH1 96-402 from the HILGE assembly tool kit (pos. 6, Fig. 55).

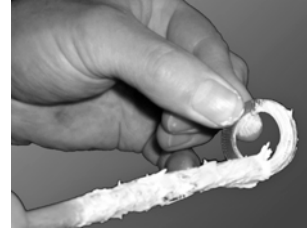

Fig. 46 Nord-lock washer

24. Insert Nord-Lock washer into the impeller nut 0922.00.



Fig. 47 Impeller nut assembly

- Grease Nord-Lock washers as shown in Fig. 48.

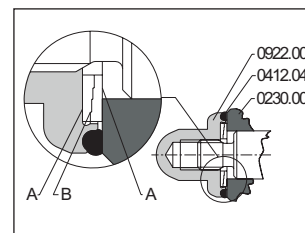

Fig. 48 Schema of Nord-Lock washer greasing

- 0230.00 impeller
- 0412.04 O-ring
- 0922.00 impeller nut
- A - fine tothing greased
- B - thick tothing against each other - greased

25. Grease the thread of the pump shaft.
Use Klüberpaste UH1 96-402 from Hilge assembly tool kit (pos. 6, Fig. 55).



Fig. 49 Impeller nut

26. Tighten impeller nut 0922.00 by using a torque wrench.
Torques: M8: 20 Nm



Fig. 50 Torque wrench

27. Assemble suction cover 0162.00.



Fig. 51 Suction cover

28. Assemble clamp ring 0515.01.



Fig. 52 Clamp ring

29. Fix clamp ring 0515.01 by using hexagon nuts 0920.22 and spring washers 0934.03.



Fig. 53 Hexagon nut

30. Tighten the hexagon nuts 0920.22 up to the stop.
Use a socket wrench to do this.



Fig. 54 Socket wrench

6.5 Troubleshooting

Problem	Cause	Remedy
Pump does not deliver or delivers at a reduced rate.	<ol style="list-style-type: none"> 1. Incorrect electrical hook-up (2 phases). 2. Wrong rotational direction. 3. Air in the suction line or in the pump.^a 4. Back pressure too high. 5. Suction head too high, NPSH feed too low. 6. Lines clogged or foreign material in the impeller. 7. Air inclusions as a result of a defective seal. 	<ol style="list-style-type: none"> 1. Check the electrical connections and correct them if necessary. 2. Reverse the phases of the power supply (reverse the polarity). 3. Vent the suction line or the pump and refill. 4. Reset the operating point according to the data sheet. Check system for contamination. 5. Raise the liquid level on the suction side. Open the shut-off valve in the suction line all the way. Produce the conditions described in 3.3, page 13. Consult manufacturer. 6. Open the pump and fix the problem. 7. Check the pipeline seals, the pump housing seals, and the shaft seals. Replace if necessary.
Motor safety switch turns motor off. Motor is overloaded.	<ol style="list-style-type: none"> 1. Pump jammed because of clogging. 2. Pump jammed by contact because pump body was twisted by the pipelines. (Check for damage). 3. Pump continues to run beyond the rated operating point. 4. The density or viscosity of the pumping medium is higher than the value stated in the order. 5. Motor safety switch not properly adjusted. 6. Motor running on 2 phases. 	<ol style="list-style-type: none"> 1. Open the pump and fix the problem. 2. Install the pump so that there is no stress on it. Support the pipelines at fixed points. 3. Set the operating point according to the data sheet. 4. If it is acceptable for the performance to be lower than that stated, decrease the delivery rate on the pressure side. Otherwise, use a more powerful motor. Consult manufacturer. 5. Check the setting. Replace the safety switch if necessary. 6. Check the electrical connections. Replace defective fuses.
Pump produces too much noise. Pump runs roughly and vibrates.	<ol style="list-style-type: none"> 1. Suction head too high, NPSH feed too low. 2. Air in the suction line or in the pump.^a 3. Back pressure lower than stated. 4. Impeller out of balance. 5. Internal parts worn. 6. Pump is twisted (causing contact noises). Check for damage. 7. Bearings are defective. 8. Bearings have too little, too much, or the wrong kind of lubricant. 9. Motor cooling fan defective. 10. Gear ring of the coupling (power transmission) defective.^b 11. Foreign material in the pump. 	<ol style="list-style-type: none"> 1. Raise the liquid level on the suction side. Open the shut-off valve in the suction line all the way. Produce the conditions described in Section 3.3, page 13. Consult manufacturer. 2. Vent the suction line or the pump and refill. 3. Set the operating point according to the data sheet. 4. Clean, inspect, and rebalance the impeller. 5. Replace parts. 6. Install the pump so that there is no stress on it. Support the pipelines at fixed points. 7. Replace the bearings. 8. Add more lubricant, decrease the amount, or replace the lubricant. 9. Replace the motor cooling fan. 10. Replace the gear ring of the coupling. Realign the coupling. 11. Open the pump and clean it (install a screen in front of self-priming pumps, if necessary).

Table 7 Troubleshooting

Problem	Cause	Remedy
Leakage at the pump body, at the connections, at the mechanical seal and at the stuffing box or gland seal.	<ol style="list-style-type: none"> 1. Pump is twisted (causing leaks at the pump body or at the connections). 2. Housing seals and seals at the connections are defective. 3. Rotating mechanical seal dirty or stuck. 4. Rotating mechanical seal worn. 5. Stuffing box packing worn out. 6. Surface of shaft or shaft safety sleeve worn down. 7. Elastomer unsuitable for the pumping medium. 	<ol style="list-style-type: none"> 1. Install the pump so that there is no stress on it. Support the pipelines at fixed points. 2. Replace the housing seals or the seals of the connections. 3. Inspect and clean the rotating mechanical seal. 4. Replace mechanical seal. 5. Tighten the stuffing box packing, add more packing, or replace the packing. 6. Replace the shaft or the shaft safety sleeve. Repack the stuffing box. 7. Use an elastomer suitable for the pumping medium and the temperature.
Unallowable temperature increase at the pump, bearing housing, or motor.	<ol style="list-style-type: none"> 1. Air in the suction line or in the pump.^a 2. Bearings have too little, too much, or the wrong kind of lubricant. 3. Pump and bearing housing are twisted. 4. Axial thrust too high.^a 5. Motor safety switch is defective or not properly adjusted. 6. Pressure valve closed. 	<ol style="list-style-type: none"> 1. Vent the suction line or the pump and refill. 2. Add more lubricant, decrease the amount, or replace it. 3. Install the pump so that there is no stress on it. Support the pipelines at fixed points. Check the alignment of the coupling. 4. Inspect the relief holes in the impeller and the split rings at the inlet. 5. Check the adjustment. Replace the motor safety switch if necessary. 6. Open the pressure valve.

Table 7 Troubleshooting

- a. Applies not to self priming pumps.
- b. Applies to CN baseplate design.

6.6 Disposal

This product or parts of it must be disposed of in an environmentally sound way:

1. Use the public or private waste collection service.
2. If this is not possible, contact the nearest GEA Hilge company or service workshop.

6.7 HILGE assembly tool kit

Remove and install the mechanical seals safely and reliably by using tools of the HILGE assembly tool kit.

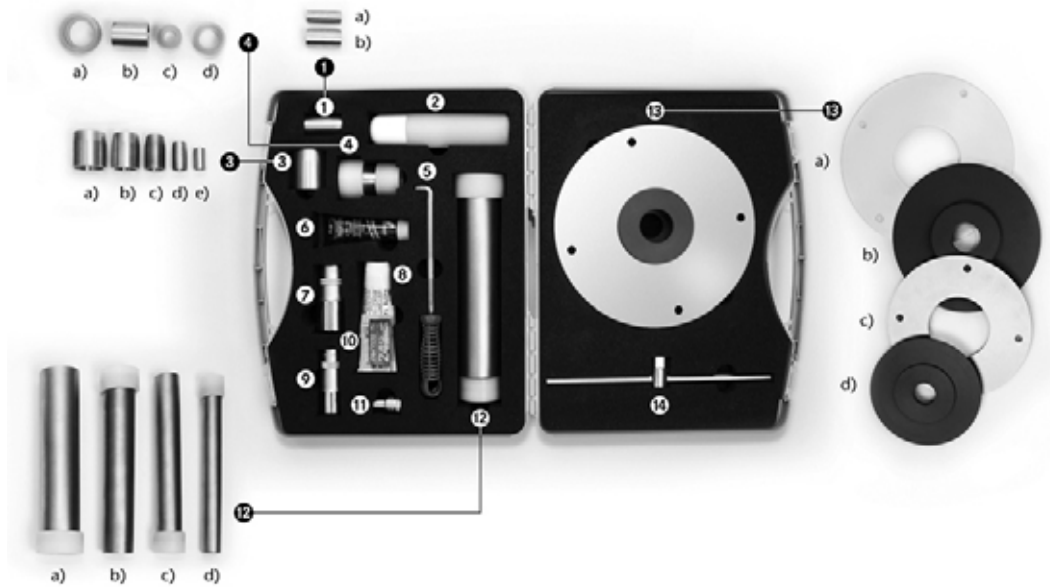

K_0286V1

Fig. 55 HILGE assembly tool kit

6.7.1 Content and use

Item (fig.)	Description	durietta I
1a	assembly sleeve Ø 19	●
2	spray bottle	●
5	ejector for mechanical seal - stationary ring	●
6	Klüberpaste UH1 84-201	●
8	Optimol Paste TA	●
10	screw locking Loctite Type 243	●
12d	mechanical seal installation sleeve Ø 19 and Ø 22	●
12d	plastic adapter Ø 19	●
13c	impeller fastening aid	●

Tab. 8 Content HILGE assembly tool kit

7. Certificate of non-objection

Abstract

This section contains a certificate of non-objection. In case of inspection or repairing send the pump including these certificate to HILGE.

7.1 Certificate of non-objection

The following pump and its accessories, together with this certificate of non-objection, are herewith contracted out by the undersigned for inspection/repair:

- Pump data
- Model:
 - No.:
 - Delivery Date:

Reason for inspection / repair contract:

The pump (please mark with a cross)

___ was not used in media hazardous to health

___ was used for the following: _____

Please state the last medium to be pumped, if known:

The pump was carefully drained and also cleaned inside and out before it was shipped/made available. (please mark with a cross)

___ No special safety measures are required in the course of further handling.

___ The following safety measures pertaining to flushing media, residual liquids, and disposal are required:

We confirm that the information given above is correct and complete and that shipment is in compliance with legal regulations.

Company (address):

Telephone, fax, email

Name (please print), title

Date

Company stamp / signature



Excellence

Passion

Integrity

Responsibility

GEA-iversity

GEA Group is a global engineering company with multi-billion euro sales and operations in more than 50 countries. Founded in 1881, the company is one of the largest providers of innovative equipment and process technology. GEA Group is listed in the STOXX Europe 600 Index.



GEA Hilge

Hilge GmbH & Co. KG

Hilgestraße 37-47, 55294 Bodenheim, Germany

Phone: +49 6135 75-0, Fax: +49 6135 754955

gea.com