

OPERATING INSTRUCTIONS

Original instructions



GEA Hilge HYGIA K

Hygienic pumps

GEA Hilge Niederlassung der GEA Tuchenhagen GmbH

BA.H2A.KYY.001.GB_4

09.2023 / Revision: 1 / Language: English

Copyright © GEA Hilge, subsidiary of GEA Tuchenhausen GmbH 2023. All rights reserved.
No liability will be accepted for damage resulting from non-observance of this document.
If you have any questions or require clarification concerning the use of this document,
contact the *Customer service*.

Table of Contents

1 General

1.1	Information about the document.....	7
1.1.1	Purpose and structure of the document.....	7
1.1.2	Design elements.....	7
1.1.3	Reading obligation and storage.....	8
1.1.4	Respective documents.....	8
1.2	Manufacturer address.....	8
1.3	Customer service.....	8
1.4	Declarations of conformity.....	9

2 Safety

2.1	Intended use.....	13
2.1.1	Pumped fluids.....	13
2.1.2	Connections and pipelines.....	13
2.1.3	Types.....	13
2.1.4	Starting frequency.....	13
2.2	Modification.....	13
2.3	Structure of warning notices.....	14
2.3.1	Preceding warning notices.....	14
2.3.2	Integrated warning notices.....	14
2.3.3	Signal words.....	14
2.4	Personnel qualification.....	15
2.5	General safety instructions.....	15
2.5.1	General hazard.....	15
2.5.2	Mechanical hazard.....	16
2.5.3	Electrical hazard.....	16
2.5.4	Thermal hazard.....	17
2.5.5	Hazard caused by noise.....	17
2.5.6	Hazard through vibration.....	17
2.5.7	Radiation hazard.....	17
2.5.8	Hazard due to operating environment.....	18
2.5.9	Ergonomic hazard.....	18
2.5.10	Hazard through hazardous substances.....	18
2.6	Personal protective equipment.....	18
2.7	Safety devices.....	19
2.8	Residual hazards.....	19
2.9	Safety signs.....	19
2.10	Emergency measures.....	20

3 Description

3.1	Set-up and function.....	21
3.1.1	Component overview	21
3.1.2	Structure and quality.....	21
	Areas of application	22
	Hygienic design applications	22
	Pump denomination	22
3.2	Signs.....	23
3.3	Protective devices.....	24
3.4	Technical data.....	24
3.4.1	Type plate.....	24
3.4.2	Weights	24
3.4.3	Torques.....	26
3.4.4	Serial number	27
3.4.5	Performance specifications.....	27
3.4.6	Noise emissions.....	27
3.4.7	Operating temperatures.....	28
	Maximum media temperatures.....	28
	Ambient temperatures.....	28
3.4.8	Maximum operating pressure	28
3.4.9	Resistance of sealing materials.....	29
3.4.10	Minimum flow rate	30

4 Storage and transport

4.1	Storage.....	31
4.2	Transport aids	31
4.3	Transport.....	31

5 Assembly and installation

5.1	Requirements on the place of use.....	33
5.1.1	Reducing noises and vibration	35
5.2	Assembly preparations.....	37
5.3	Set-up, assembly, connection	38
5.3.1	Installation in the piping system	39
5.3.2	Connecting the flushing.....	39
	Quench version (optional).....	40
5.3.3	Connecting the pump to the power supply	42
	Operator-side pre-requisites equipotential bonding	42
	Connecting frequency inverter	46

6	Commissioning	
6.1	Preparing commissioning	49
6.2	Operating conditions.....	49
6.3	Initial start-up.....	50
6.4	Restarting	51
6.5	Monitoring operation.....	51
6.6	Shutdown.....	52
7	Cleaning	
7.1	General points.....	53
7.2	CIP cleaning	53
7.3	Cleaning at standstill.....	54
8	Maintenance	
8.1	Maintenance and inspection	55
	8.1.1 Maintenance jobs.....	57
8.2	Disassembly.....	58
	8.2.1 Removing the shaft sleeve.....	58
8.3	Assembly.....	59
	8.3.1 Installation instructions.....	66
	8.3.2 Installing shaft sleeve.....	67
	8.3.3 Installing the motor, motor stool and pump shaft.....	69
	8.3.4 Determining the gap size.....	74
	8.3.5 Installing single mechanical seal	77
	8.3.6 Installing the single encapsulated mechanical seal	79
	8.3.7 Install impeller	80
	8.3.8 Installing pump casing.....	84
9	Faults	
9.1	Faults and remedies.....	87
10	Decommissioning, dismantling and disposal	
10.1	Decommissioning.....	91
10.2	Dismantling.....	91
10.3	Disposal.....	92
11	Annex	
11.1	Clearance certificate.....	93

1 General

This chapter contains basic instructions on the use of this document and explanations of typographical conventions. In addition, this chapter contains details on the version and structure.

In this document, the term pump refers to GEA Hilge HYGIA K.

1.1 Information about the document

1.1.1 Purpose and structure of the document

The purpose of this Operating Manual is to convey information on operation of the pump. It is divided into several chapters for this purpose. This structure is oriented towards the various life phases of the pump. When the contents are observed, the service life and reliability of the pump increased and the risk of personal injuries and property damage are reduced. In addition, the Operating Manual is applicable for the operator as a basis for compiling instruction manuals.

1.1.2 Design elements

In this document, the following design elements are used as orientation aids.

General orientation aids

- Figure numbers
- Table numbers
- Chapter numbers
- Page numbers
- Headers and footers
- References
- Lists

Lists

Bullet points are shown in lists and do not prescribe a specific sequence.

- Bullet point
- Bullet point
 - Sub-point
 - Sub-point
- Bullet point

Numbered lists

In a sequence of actions, the order of the action steps is specified by a numbered list. Partial results and the result of a sequence of actions are marked by arrows.

1. Action step one
2. Action step two
 - 2.1 First sub-step two
 - 2.2 Second sub-step two
 - Partial result
3. Action step three
 - Partial result
4. Action step four
 - ⇒ Result

INFO

Info texts contain additional information about a description or action step.

1.1.3 Reading obligation and storage

This document must be read by every person who carries out actions at the pump and must be available for these persons at all times.

1.1.4 Respective documents

In this Operating Manual, reference is made to the documents listed below.

GEA documents

- Pump data sheet
- ATEX supplementary operating manual for pumps approved for use in potentially explosive atmospheres.

External documents

- Operating manual for motor

The documents named are not part of this Operating Manual. Documents which are not available can be requested from GEA Hilge.

1.2 Manufacturer address

GEA Hilge, subsidiary of GEA Tuchenhausen GmbH

Hilgestrasse 37-47

Germany

55294 Bodenheim

1.3 Customer service

Phone: +49 (0) 6135 7016-0

Fax: +49 (0) 6135 759 55

Spare parts: spareparts.hilge@gea.com

Technical Service: hilge.technicalservice@gea.com

www.gea.com

1.4 Declarations of conformity



**EG - Konformitätserklärung für Maschinen
im Sinne der EG-Maschinenrichtlinie 2006/42/EG, Anhang II 1. A**

Hersteller: **GEA HILGE
Niederlassung der GEA Tuchenhagen GmbH
Hilgestraße 37-47
D 55294 Bodenheim**

Wir als Hersteller erklären in alleiniger Verantwortung, dass die Maschine

Bezeichnung: Kreiselpumpe
Modell / Typ: GEA Hilge HYGIA I ADAPTA, ADAPTA-SUPER
GEA Hilge HYGIA II ADAPTA, ADAPTA-SUPER
GEA Hilge HYGIA I K, K-SUPER
GEA Hilge HYGIA II K, K-SUPER

allen einschlägigen Bestimmungen dieser und folgender Richtlinien entspricht:

Einschlägige EG-Richtlinien: 2006/42/EG EG-Maschinenrichtlinie

Angewandte harmonisierte Normen, insbesondere: EN 809:1998/A1+AC(D)

EN ISO 12100:2010

Bemerkungen: Ferner erklären wir, dass die speziellen technischen Unterlagen für diese Maschine nach Anhang VII Teil A erstellt wurden und verpflichten uns, diese auf begründetes Verlangen der einzelstaatlichen Stellen per Datenträger zu übermitteln.

Bevollmächtigte Person für die Zusammenstellung und Übergabe von technischen Unterlagen: **GEA HILGE
Niederlassung der GEA Tuchenhagen GmbH
Hilgestraße 37-47
55294 Bodenheim, Deutschland**

Bodenheim, den 10.11.2022



Karsten Becker
Geschäftsführer



i. V. Dr. Danijel Anciger
Leiter Produktentwicklung

CO.099.YYY.014DE_R1

Translation of the EC Declaration of Conformity for Machines in accordance with the EC Machinery Directive 2006/42/EC, Annex II 1. A

Manufacturer:	GEA HILGE Subsidiary of GEA Tuchenhausen GmbH Hilgestrasse 37-47 55294 Bodenheim Germany
We declare under our sole responsibility that the machine	
Designation:	Centrifugal pump
Model / type:	GEA Hilge HYGIA I ADAPTA, ADAPTA-SUPER GEA Hilge HYGIA II ADAPTA, ADAPTA-SUPER GEA Hilge HYGIA I K, K-SUPER GEA Hilge HYGIA II K, K-SUPER
conforms with all the relevant provisions of this directive and the following directives:	
Relevant EC directives:	2006/42/EC – EC Machinery Directive
Applicable harmonized standards, in particular:	EN 809:1998/A1+AC(D) EN ISO 12100:2010
Remarks:	We also declare that the relevant technical documentation for this machine has been prepared in accordance with Annex VII, Part A, and agree to submit the documentation on justified request of national authorities on a data carrier.
Person authorised for compilation and handover of technical documentation:	GEA HILGE Subsidiary of GEA Tuchenhausen GmbH Hilgestrasse 37-47 55294 Bodenheim Germany
Bodenheim, 10.11.2022	
Karsten Becker Managing Director	i.V. Dr. Danijel Anciger Manager Product Development

UKCA - Declaration of Conformity

We herewith declare,

**GEA HILGE
Niederlassung der GEA Tuchenhagen GmbH
Hilgestraße 37-47
D 55294 Bodenheim**

that the machinery

Denomination: Centrifugal pump
Model / Type: GEA Hilge HYGIA I ADAPTA, ADAPTA-SUPER
GEA Hilge HYGIA II ADAPTA, ADAPTA-SUPER
GEA Hilge HYGIA I K, K-SUPER
GEA Hilge HYGIA II K, K-SUPER

is in conformity with the following UK-directives, provided that the site conditions for the commissioning are met as specified in the engineering documents, in particular in the operation manual:

Supply of Machinery (Safety) Regulations 2008, 2008 No. 1597

Designated standards used: EN 809:1998+A1:2009+AC(D)
EN ISO 12100:2010

Authorized person for compiling and handing over technical documentation: **GEA Mechanical Equipment UK Ltd
Westfalia House
Old Wolverton Road, Old Wolverton, Milton Keynes
MK12 5PY, United Kingdom**

Bodenheim, den 10.11.2022



Karsten Becker
Managing Director



i. V. Dr. Danijel Anciger
Manager Product Development

2 Safety

This chapter describes the minimum requirements for intended use of the pump. It forms the basis for safe operation of the pump.

2.1 Intended use

The pump has been specially designed.

- Pump only media that are specified on the pump data sheet.
- Operate the pump only in the electrical grid that was specified on the pump data sheet.

2.1.1 Pumped fluids

Use only clean or lightly polluted liquids as pumped fluids as long as they do not chemically or mechanically attack the pump materials or reduce their strength. If you want to pump liquids with higher viscosity than that of water, check for possible overload of the motor.

2.1.2 Connections and pipelines

The pipe nominal diameters of the system should be equal to or greater than the pump nominal diameters DNE (suction side) or DNA (pressure side), and the fittings to the pump should match exactly the type standard of the fixed mating connection part on the pump. The suction line must be hermetically sealed and routed such that no air pockets can form. Avoid tight bends and valves directly in front of the pump. On the suction side, a straight settling section with a minimum length of 5 times the pipe diameter should be provided. The suction head of the system must not be larger than the suction head guaranteed by the pump.

2.1.3 Types

All information and descriptions in this operating manual on the use and handling of the pump refer exclusively to the standard versions. Special designs and customised deviations as well as random external influences in the use and operation are not included in these instructions.

2.1.4 Starting frequency

The switching frequency of pumps describes the number of times electric motors are started up per hour. Frequent switching increases wear and reduces the life span of the mechanical seal, so 15 switch-on processes per hour should not be exceeded.



Starting frequency

Do not exceed the switching frequency of the motor used. Observe the motor operating manual for details of starting frequency.

2.2 Modification

Modification or alteration of the pump is only permitted with the written permission of GEA Hilge. Modifications can endanger the operating safety and lead to personal injuries and property damage. Exclusive use of original spare parts and accessories authorised by GEA Hilge ensures safety. The manufacturer will bear no liability for consequences arising from the use of unauthorised parts.

2.3 Structure of warning notices

Warning notices warn of hazards which can occur when certain actions are carried out. The warning notices described below are used in this document. The extent of hazards is classified in risk levels and can be recognised by the respective signal words.

2.3.1 Preceding warning notices

Preceding warning notices are used when there is a hazard during a sequence of actions. Warning notices are colour-highlighted and supplemented by a pictogram in the event of possible personal injury.

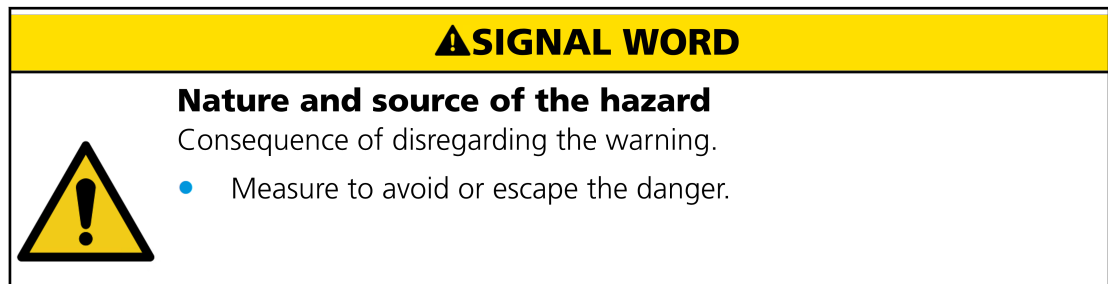

Figure 2-1 - Structure of a preceding warning notice

2.3.2 Integrated warning notices

Integrated warning notices are used when there is a hazard involved in a single action step.

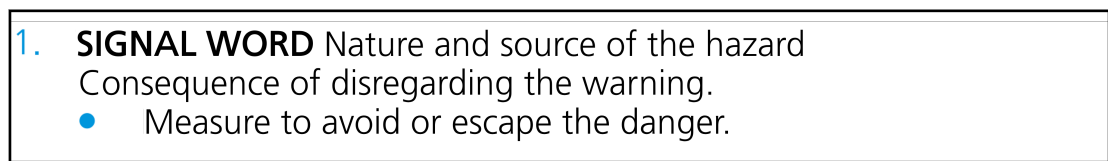

Figure 2-2 - Structure of an integrated warning notice

2.3.3 Signal words

IMPORTANT

The signal word **IMPORTANT** indicates a hazard that could result in property damage if not avoided.

CAUTION

The signal word **CAUTION** indicates a hazard with a low risk level which could result in light to medium injuries if not avoided.

WARNING

The signal word **WARNING** indicates a hazard with a medium risk level which could result in death or severe injury if not avoided.

DANGER

The signal word **DANGER** indicates a hazard with a high risk level which will result in death or serious injury if not avoided.

2.4 Personnel qualification

The basic pre-requisites listed below must always be fulfilled for all actions on the pump.

- This Operating Manual has been read and understood.
- Safety-related tasks in the vicinity of the pump are regulated and assigned.
 - Maintaining order
 - Compliance with safety requirements
 - Securing of danger areas

The groups of people named below must also have the personnel qualifications or skills listed below and be authorised for actions at the pump by the operator.

operating staff

- Instructed by the operator, a trained customer specialist or a GEA service specialist

customer specialist

- Technical training

trained customer specialist

- Technical training in a specific specialist area
- Training by GEA personnel or participation in training at GEA Hilge

GEA service specialist

- Personnel from GEA Hilge, see *1.3 Customer service*

Where necessary, reference is made to the respective group of people in this Operating Manual.

2.5 General safety instructions

The pump has been built according to state-of-the-art and the recognised safety regulations valid at the time it is put into circulation. Nevertheless, the measures stipulated by the operator and listed below must be kept in order to maintain safety.

2.5.1 General hazard

Source	Consequences	Measures
Machine not in proper condition	Personal injuries and property damage	Check proper condition of the pump.
Non-observance of this Operating Manual	Personal injuries and property damage	Read this Operating Manual completely and understand it.
Operating media	Personal injuries	<ul style="list-style-type: none"> • Wear personal protective equipment. • Avoid contact with operating media.

2.5.2 Mechanical hazard

Source	Consequences	Measures
Moving or rotating components	<ul style="list-style-type: none"> • Being drawn in or caught • Entrapment • Crushing • Impact 	<ul style="list-style-type: none"> • Remove jewellery. • Tie hair back or wear a hair net. • Wear tight-fitting clothing.
<ul style="list-style-type: none"> • Sharp edges • Cutting parts • Pointed parts 	<ul style="list-style-type: none"> • Cutting or shearing • Penetration or puncture • Shearing • Rubbing or grazing 	<ul style="list-style-type: none"> • Wear personal protective gear. • Use transport protection and available jigs.
<ul style="list-style-type: none"> • Rough or slippery surfaces • Stumbling hazards 	<ul style="list-style-type: none"> • Slipping • Stumbling • Falling 	<ul style="list-style-type: none"> • Wear personal protective gear. • Eliminate leaked liquids and stumbling hazards.
<ul style="list-style-type: none"> • Gravity • Falling objects 	<ul style="list-style-type: none"> • Impact • Crushing 	<ul style="list-style-type: none"> • Do not walk under suspended loads. • Eliminate the stumbling hazards. • Only move mobile pumps on level surfaces.
Height above the ground	Falling	Use supports and permitted climbing aids.

2.5.3 Electrical hazard

Source	Consequences	Measures
Electromagnetic processes	Implications for electronic medical implants	People with medical implants must keep their distance.
Electrostatic processes	<ul style="list-style-type: none"> • Electric shock • Fire • Chemical reaction 	<ul style="list-style-type: none"> • Avoid contact to components. • Check the voltage of components. • Wear personal protective gear. • Eliminate leaked flammable substances.

2.5.4 Thermal hazard

Source	Consequences	Measures
Objects or materials at high or low temperature	<ul style="list-style-type: none"> • Freezing • Burns • Scalding 	<ul style="list-style-type: none"> • Wear personal protective gear. • Wait for adjustment to room temperature.
Radiation from heat sources	<ul style="list-style-type: none"> • Burns • Discomfort 	<ul style="list-style-type: none"> • Wear personal protective gear. • Keep time spent to a minimum.

2.5.5 Hazard caused by noise

Source	Consequences	Measures
Manufacturing process or production process	<ul style="list-style-type: none"> • Permanent hearing loss • Tinnitus (ringing in the ears) • Dizziness • Discomfort • Loss of consciousness • Fatigue • Stress 	<ul style="list-style-type: none"> • Keep time spent at a minimum. • Wear personal protective gear.

2.5.6 Hazard through vibration

Source	Consequences	Measures
<ul style="list-style-type: none"> • Moving equipment • Cavitation processes • Frictional surfaces • Vibratory equipment 	Discomfort	Keep time spent at a minimum.

2.5.7 Radiation hazard

Source	Consequences	Measures
<ul style="list-style-type: none"> • Optical radiation • Laser beams 	<ul style="list-style-type: none"> • Eye damage • Skin damage 	<ul style="list-style-type: none"> • Wear personal protective gear. • Avoid looking at the source of radiation.

2.5.8 Hazard due to operating environment

Source	Consequences	Measures
<ul style="list-style-type: none"> • Lightning • Electromagnetic interference • Humidity • Lack of oxygen • Snow • Dust and fog • Temperature • Contamination • Water • Wind 	Personal injuries and property damage	<ul style="list-style-type: none"> • Take note of the permissible operating conditions, see chapter 5.1 <i>Requirements on the place of use</i>.

2.5.9 Ergonomic hazard

Source	Consequences	Measures
<ul style="list-style-type: none"> • Flickering • Orifice plates • Shadow formation • Stroboscopic effects 	Discomfort	<ul style="list-style-type: none"> • Avoid looking into the source. • Keep time spent at a minimum.

2.5.10 Hazard through hazardous substances

Source	Consequences	Measures
<ul style="list-style-type: none"> • Dangerous media • Operating media • Cleaning agents 	<ul style="list-style-type: none"> • Caustic and irritant effect on eyes, skin and the respiratory system • Material damage to surfaces and seals 	<ul style="list-style-type: none"> • Wear personal protective equipment. • Observe the product data sheet and manufacturer information. • Conduct leakages away in such a way that they do not present a hazard.
<ul style="list-style-type: none"> • Decontamination • Contamination 	<ul style="list-style-type: none"> • Poisoning • Infections 	<ul style="list-style-type: none"> • Make sure there are no objects in the pump. • Clean the pump before initial start-up and after all assembly work. • Carry out CIP and SIP cleaning cycle.

2.6 Personal protective equipment

To prevent possible personal injuries, the personal protection equipment must be worn.

In addition, GEA recommends keeping the requirements listed below.

- Locally applicable accident prevention regulations
- Instruction manual from the operator or employer

2.7 Safety devices

Safety devices monitor operating parameters. To protect the pump, measures are initiated automatically if the specified tolerance values are exceeded.

If one of the safety devices triggers stopping of the pump, the pump may only be re-started after the cause has been determined and eliminated.

There are no safety devices installed on this pump.

2.8 Residual hazards

Despite all the measures taken, the following residual hazards can lead to personal injuries and property damage at any time.

- Improper use
- Material fatigue
- Failure of safety devices

2.9 Safety signs

The following safety signs are used in these Operating Manual or are attached to the pump.

The position of the safety signs used on the pump is shown on an overview diagram, see *3.2 Signs*.

Signs giving orders



Observe manual

Hazard if this Operating Manual is not read before actions at the pump.

Warning signs



General warning sign

Hazard for persons, conveyed by the additional sign.



Beware of electric voltage

Hazard due to contact with electric voltage.



Beware of hot surface

Hazard due to contact with hot surface.

2.10 Emergency measures

If an emergency occurs at the pump, the company regulations must be followed and the measures listed below must be taken.

Fire

- Call local experts
- Use extinguishing equipment according to company regulations
- Leave the danger area
- Warn endangered persons

Personal injuries

- Do first aid
- Call local emergency services

3 Description

This chapter contains descriptions of the set-up and function of the pump.

3.1 Set-up and function

3.1.1 Component overview

HYGIA K

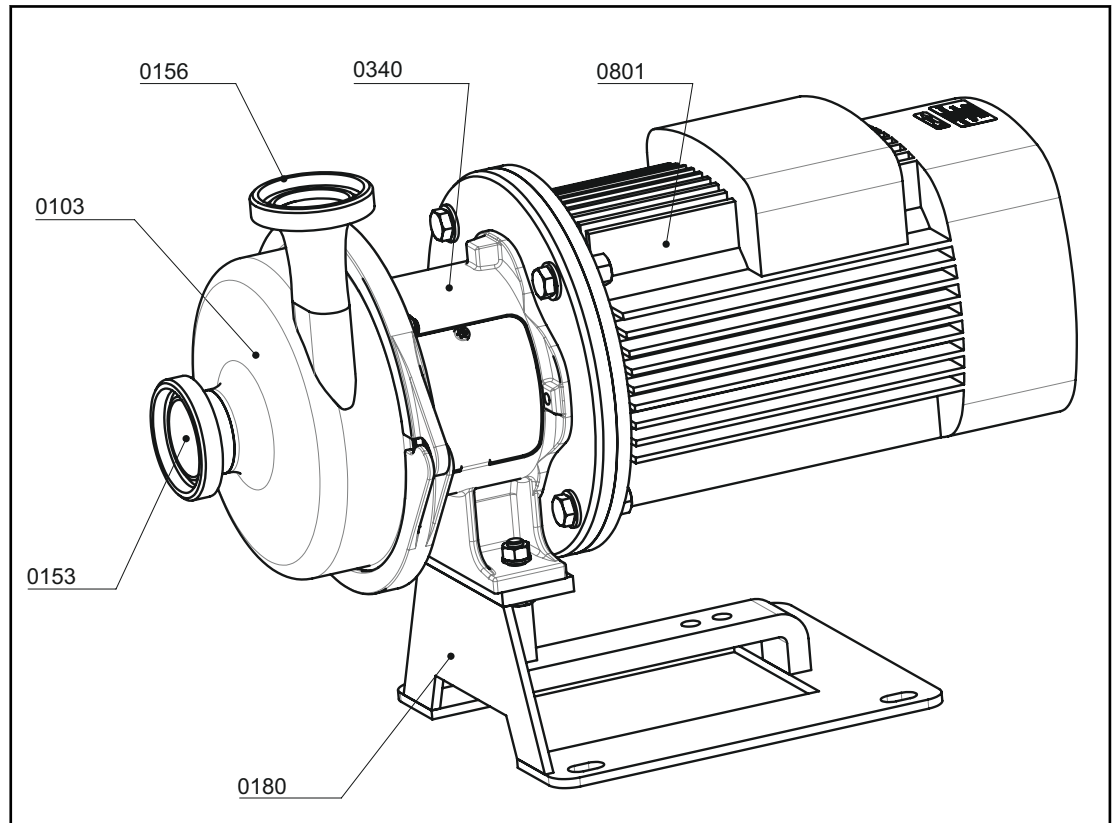

Figure 3-1 - Overview diagram of the components

Position	Designation	Position	Designation
0103	Annular casing	0180	Stainless steel foot
0153	Suction port	0340	Motor stool
0156	Discharge port	0801	Motor

3.1.2 Structure and quality

The pump is a non self-priming, single-stage centrifugal pump in system block design. All parts in contact with media are based on the "hygienic design" guidelines. The material grade 1.4404 or 1.4435 Fe ≤ 1% and the respective execution standard are carried out according to the order and, if required, certified in writing.

3.1.2.1 Areas of application

The standard version of the pumps is used in the following areas:

- Breweries (beer, wort, mash, yeast, etc.)
- Dairies (milk, milk mixes, cheese production, etc.)
- Soft drinks (fruit juice, lemonade, mineral water, etc.)
- Wine and sparkling wine production
- Distilleries (mash, distillates, etc.)
- Food production (marinades, pickle, cooking oil, etc.)
- Cleaning systems (CIP)

3.1.2.2 Hygienic design applications

Due to the consistent hygienic design and the use of pore and porosity-free materials, the pump is ideally suited for use in the following areas:

- Pharmaceutical industry
- Medical technology
- In biotechnology process plants

Special applications arise in the area of cure water pumping / WFI, as well as in equipment for the production of parenterals and infusion solutions according to FDA.

Pumps for hygienic design applications

Pumps used for hygienic applications must have certain equipment features and are configured accordingly when ordered. Execute connections in accordance with the "EHEDG White Paper on GFSI Hygienic Design Scope".

3.1.2.3 Pump denomination

GEA Hilge HYGIA	N	C	40/40	3	2
Pump name	Size	Design type	Nominal width	Output [kW]	Number of poles

3.2 Signs

Overview and layout

All safety signs and labels must meet the following criteria during the entire life span of the pump:

- Complete
- Attached as illustrated
- Clean and legible

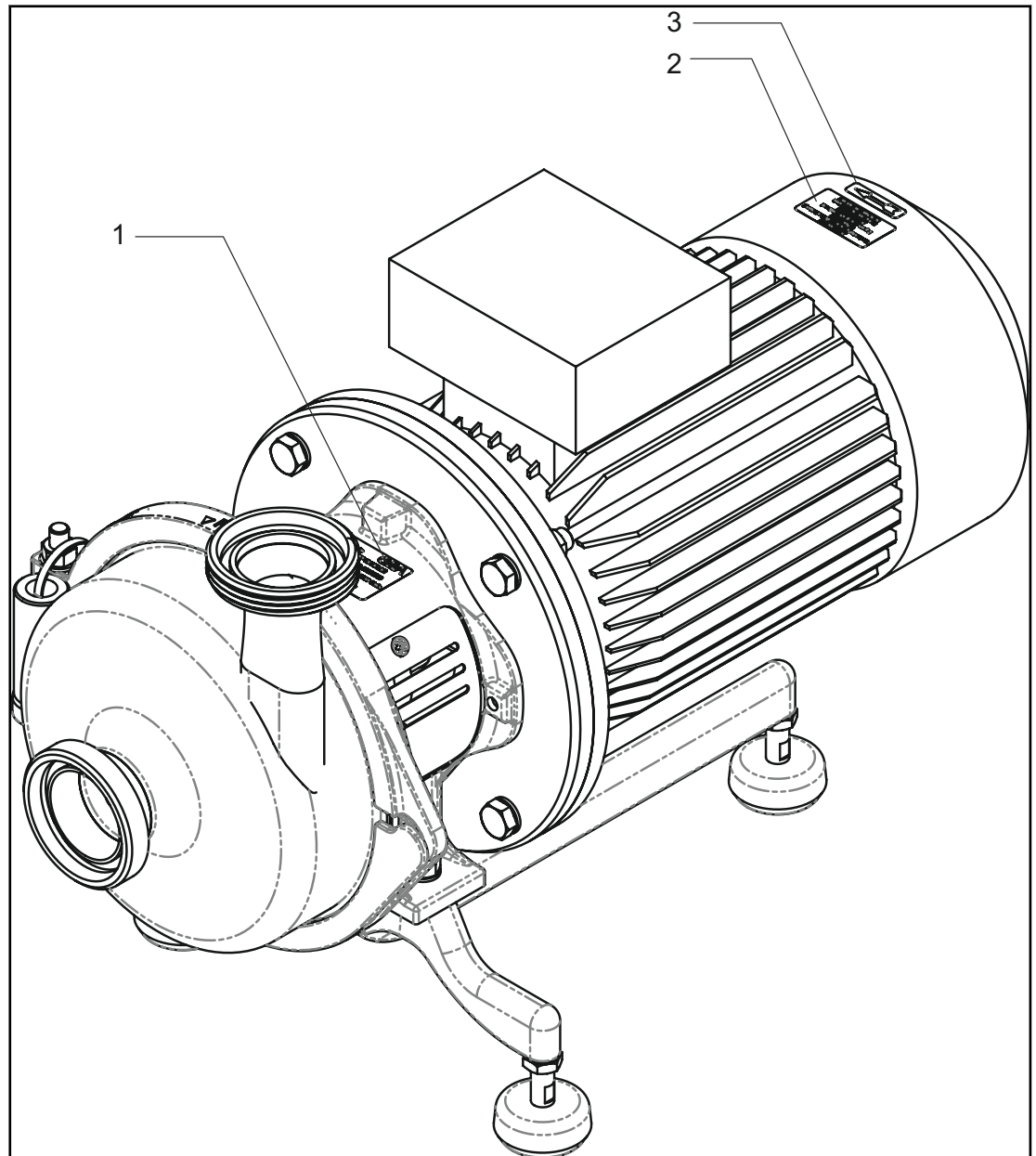

Figure 3-2 - Overview diagram of the signs on the pump

Position Description	Position Description
1 Nameplate	3 Rotation arrow
2 Caution dry running	

The representation and meaning of the safety signs used are listed in an overview according to their category, see chapter *2.9 Safety signs*

3.3 Protective devices

The motor stool is equipped with two safety plates to guard the shaft connection.

3.4 Technical data

3.4.1 Type plate

Each pump carries a nameplate. For information about exact positioning, see chapter 3.2 *Signs*.

The nameplate contains the following information:

- Manufacturer name and address
- Product safety mark
- Pump type: pump denomination
- Ser.no: serial number
- Q: flow rate
- H: head
- P: Motor rating
- n: speed
- YOM: year of manufacture
- TAG No.:customer name

3.4.2 Weights

The weights may differ from the ones shown here depending on the version and accessories. Please contact the manufacturer for accurate information and quote the pump / order number.

Weight [kg] - HYGIA I K

Motor P2 [kW]	Pole	Motor IEC	Motor foot	Cast foot	Stainless steel foot	Combi foot	SUPER combi foot	SUPER cast foot	SUPER stainless steel foot	SUPER tronic combi foot	SUPER tronic cast foot	SUPER tronic stainless steel foot
0.75	4	80	31.9	39.4	39.9	34.6	43.8	48.6	45.1	39.7	44.5	41
1.1	2	80	32.4	39.9	36.4	35.1	44.3	49.1	45.6	39.2	44	40.5
1.1	4	90S	37	44.5	41	39.7	48	52.8	49.3	41.8	46.6	43.1
1.5	2	90S	39	46.5	43	41.7	50	54.8	51.3	40.3	45.1	41.6
1.5	4	90L	54.5	62	58.5	57.2	51	55.8	52.3	62.3	67.1	63.6
2.2	2	90L	42	49.5	46	44.7	53	57.8	54.3	41.8	46.6	43.1
2.2	4	100L	58.8	65.8	62.3	61	64.3	69.1	65.8	66.1	70.9	67.4
3	2	100L	51.8	58.8	55.3	54	64.8	69.6	66.1	59.1	63.9	60.4

Motor P2 [kW]	Pole	Motor IEC	Motor foot	Cast foot	Stainless steel foot	Combi foot	SUPER combi foot	SUPER cast foot	SUPER stainless steel foot	SUPER tronic combi foot	SUPER tronic cast foot	SUPER tronic stainless steel foot
4	2	112M	62.3	69.3	65.8	64.5	73	77.9	74.4	69.6	74.4	70.9
5.5	2	132S	84.7	91.7	88.2	86.9	98.5	103.3	99.8	77	81.8	78.3

Weight [kg] HYGIA II K (1)

Motor [kW]	Pole	Motor IEC	Motor foot	Cast iron foot	Stainless steel foot	Combi foot	SUPER combi foot	SUPER cast iron foot
2.2	4	100L	57	64	60.5	59.2	70.7	75.85
3	4	100L	65	72	68.5	67.2	78.7	83.85
3	2	100L	57	64	60.5	59.2	70.7	75.85
4	4	112M	70	77	73.5	72.2	82.2	87.13
4	2	112M	66	73	69.5	68.2	79.2	84.13
5.5	4	132S	95.5	102.5	99	97.7	109.7	114.13
5.5	2	132S	91.5	98.5	95	93.7	105.7	110.13
7.5	2	132S	99.5	106.5	103	101.7	113.7	118.13
11	2	160M	125			128.8	148	

Motor [kW]	Pole	Motor IEC	Motor foot	Cast iron foot	Stainless steel foot	Combi foot	SUPER combi foot	SUPER cast iron foot
15	2	160M	131			134.8	154	
18.5	2	160L	151			154.8	174	
22	2	160L	187					

Weight [kg] HYGIA II K (2)

Motor [kW]	Pole	Motor IEC	SUPER stainless steel foot	SUPER tronic combi foot	SUPER tronic cast foot	SUPER tronic stainless steel foot
2.2	4	100L	72	63.8	68.6	65.1
3	4	100L	80	67.3	72.1	68.6
3	2	100L	72	60.8	65.6	62.1
4	4	112M	83.5	79.8	84.6	81.1
4	2	112M	80.5	72.8	77.6	74.1
5.5	4	132S	111	92.8	97.6	94.1
5.5	2	132S	107	79.3	84.1	80.6
7.5	2	132S	115	88.8	93.6	90.1

3.4.3 Torques

Element	Part number	Assembly location	Thread / torque
Hex screw	0901.32	Seal cartridge	M6 / 8 Nm
Hex screw	0901.49	Clamp shaft	M6 / tighten to 5 Nm first, then to 8 Nm
Hex socket screw	0914.05	Intermediate motor stool	M8 / 10 Nm
Hexagon nut	0920.00	Housing, clamp ring	M 10 / 35 Nm

Element	Part number	Assembly location	Thread / torque
Hexagon nut	0920.04	Back plate	M10 / 35 Nm
Hexagon nut	0920.09	Motor stool	M10 / 35 Nm M12 / 65 Nm M16 / 100 Nm
Impeller nut	0922.00	Impeller	M10 / 20 Nm M20 x 1.5 / 100-120 Nm
Cap nut	0927.00	HPM casing	M8 / 19 Nm M10 / 35 Nm

3.4.4 Serial number

The pump can be uniquely identified by the serial number. When ordering spare parts, always quote the serial number. The serial number is indicated on the nameplate.

3.4.5 Performance specifications

The performance data - delivery head and flow rate - are explained in accordance with ISO 9906:2012, Grade 2B and documented with the acceptance report.

3.4.6 Noise emissions

Measured values in accordance with DIN EN ISO 3746 for pump units, measuring uncertainty 3 dB(A).

Motor output [kW]	Lpfa [dB (A)] 2-pole	Lpfa [dB (A)] 4-pole
0.55	--	51
0.75	65	51
1.1	65	55
1.5	67	55
2.2	67	63
3	73	65
4	73	65
5.5	73	67
7.5	75	70
11	75	--
15	76	--
18.5	76	--
22	80	--

The noise emissions caused by a pump are influenced mainly by its application. The values shown here should therefore be considered merely as a guide.

3.4.7 Operating temperatures

3.4.7.1 Maximum media temperatures

Design	Temp. [°C]
Normal version	95
Sterilisation (SIP)	140

Further temperatures on request.

3.4.7.2 Ambient temperatures

Permissible ambient temperatures

Minimum temperature	Maximum temperature
0 °C	40 °C

3.4.8 Maximum operating pressure

The pump's maximum operating pressure pump depends on various factors:

- Pump type
- Type of connections
- Type of mechanical seal

Operate the pump according to the ordering data.

3.4.9 Resistance of sealing materials

The resistance and permitted operating temperature of the sealing materials depend on the type and temperature of the medium conveyed. The exposure time can adversely affect the service life of the seals. The sealing materials comply with the regulations of FDA 21 CFR 177.2600 or FDA 21 CFR 177.1550.

The maximum operating temperature is determined by the type of seal and its mechanical load. GEA Hilge recommends users carrying out resistance tests themselves in order to check the suitability of the elastomer selected for their application. Resistance of the sealing materials depend on operating conditions such as length of contact with the medium, process temperature, flow speed, concentration of the cleaning agent and ambient conditions. These can only be determined by the user. If necessary, GEA Hilge can support you with further information for special applications.

Resistance¹:

- + = good resistance
- o = reduced resistance
- - = no resistance

Medium	Temperature	Gasket material (general operating temperature)	
		EPDM -40...+135 °C (-40...275 °F)	FKM -10...+200 °C (+14...+392 °F)
Caustics up to 3%	up to 80 °C (176 °F)	+	o
Caustics up to 5%	up to 40 °C (104 °F)	+	o
Caustics up to 5%	up to 80 °C (176 °F)	+	-
Caustics at more than 5%		o	-
Inorganic acids up to 3%	up to 80 °C (176 °F)	+	+
Inorganic acids up to 5%	up to 80 °C (176 °F)	o	+
Inorganic acids up to 5%	up to 100 °C (212 °F)	-	+
Water	up to 80 °C (176 °F)	+	+
Steam	up to 135 °C (275 °F)	+	o
Steam, approx. 30 min	up to 150 °C (302 °F)	+	o
Fuels/hydrocarbons		-	+

1) depending on the installation situation

Medium	Temperature	Gasket material (general operating temperature)	
Product with a fat content of max. 35%		+	+
Product with a fat content of more than 35%		-	+
Oils		-	+

3.4.10 Minimum flow rate

Minimum flow rate depending on pump type and speed

Pump type	Speed [rpm]	Q _{min} [m ³ /h]
HYGIA I	1450	1
HYGIA I	1750	1
HYGIA I	2900	2
HYGIA I	3600	2
HYGIA II	1450	10
HYGIA II	1750	10
HYGIA II	2900	10
HYGIA II	3600	10

4 Storage and transport

This chapter contains information for the transport of the pump with and without packaging material. In addition, this chapter describes the minimum requirements for storage after delivery as well as for possible intermediate storage. The target group for this chapter are all those who perform actions related to the transport or storage of the pump.

INFO For all transport, observe chapter 2 *Safety* of this document.

4.1 Storage

Seal inlet and outlet side with a plastic cover.

Protect seals against dust and damage.

Store the pump under the following conditions:

- Do not store outdoors.
- Store dry and dust-free.
- Do not expose to aggressive media.
- Protect against sunlight.
- Protect against frost.
- Protect against rodents.
- Avoid mechanical vibrations.
- Turn the pump shaft (by approx. 30°) once every month.
- If stored for longer than three months: check the general condition of all parts and package regularly.

INFO After a storage period of more than three years: contact GEA Hilge to have the pump repaired again.

4.2 Transport aids

If the weight of the pump exceeds 40 kg, transport may only be by crane or forklift truck.

4.3 Transport

Transporting the pump with packaging

Prerequisites

- The packaging is undamaged.
- The pump is in a box on a pallet that can be driven underneath.

Tools

- Forklift truck

1. Drive the load handling equipment under the pallet and pick it up. Make sure it is aligned correctly.
2. Transport the pump to its destination.

⇒ The pump has been transported to its destination with packaging.

Unpacking the pump

Prerequisites

- The pump is in a box on a wooden pallet.
- The packaging is undamaged.

Tools

- Scissors or knife
- Gloves
- Strap, load lifting equipment with sufficient load-bearing capacity.
- Crane or forklift truck

1. **CAUTION** Injury due to packaging straps with sharp edges. Careless handling of packaging straps can lead to cuts.
 - Wear gloves.

Cut the packaging straps open and remove them.

2. Lift the box over the pump.
3. Remove fastening material on the pump.

⇒ The pump has been unpacked and can be transported to its place of use.

Transporting the pump without packaging

Prerequisites

- The shroud (if appropriate) has been removed.

Tools

- Strap, load lifting equipment with sufficient load-bearing capacity
- Forklift truck or crane

1. **ATTENTION** Danger due to unsuitable anchor points. Forces acting on the pump can damage it.
 - Never fasten a strap to the pump casing or the suction/ discharge port!

Attach the strap to suitable anchor points.

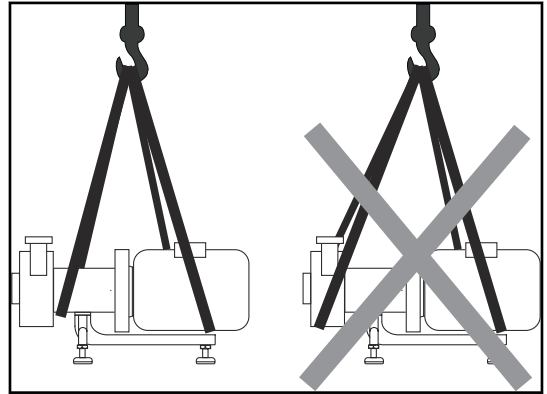

Figure 4-1 - Correct attachment of the straps

2. Align the pump horizontally during lifting.
3. Lift the pump by crane or forklift truck and transport it to the place of use.

⇒ The pump is ready for installation in the system.

5 Assembly and installation

This chapter contains information and instructions for the assembly and installation of the pump. The target group for this chapter are all those who carry out actions at the pump in this context.

INFO During assembly and installation observe chapter 2 *Safety* of this document.

5.1 Requirements on the place of use

The place of use must fulfil the requirements listed below.

- The ground must be clean, level and able to bear a sufficient load.
- There are no local oscillations that can be transferred to the pump.
- The ambient temperature is at least 0 °C up to maximum 40 °C.

Operator-side measures feed line and discharge line

- Bolt the provided fastening points to the foundation for proper setup of the pump according to the usual rules of mechanical engineering.
- Do not use the pump and its connecting pieces to support the pipeline (EN 809 5.2.1.2.3 and EN ISO 14847).
- Follow the general rules of mechanical engineering and plant construction and the regulations of the manufacturers of connecting elements (for example flanges). These regulations may include information on tightening torques, max. permissible angular misalignment, tools/equipment to use.
- Be sure to avoid any strain on the pump.
- Ensure stable construction for mounting of the pump and piping. Insufficiently stiffened substructures may cause an overall structure capable of oscillating, which is excited to oscillate by hydraulic and/or motor forces during changing operating conditions in the system.
- The suction line must be hermetically sealed and laid such that no air pockets can form.
- Avoid tight bends and valves directly in front of the pump. They impair the incoming flow of the pump and the NPSH of the system.
- The suction head of the system must not be larger than the suction head guaranteed by the pump.
- The piping nominal diameters of the system should be equal to or greater than the DNE or DNA connections of the pump.
- For suction operation, install a foot valve.
- Route the suction line in ascending direction and the supply line at a slight slope towards the pump.
- If the local conditions do not permit a continuous ascent of the suction line: Install a venting option at its highest point.
- Install a shut-off valve in the supply line close to the pump.
- Open the suction side shut-off valve completely during operation.
- Do not use the suction side shut-off valve for controlling.
- Install a shut-off valve in the pressure line close to the pump. This can be used to control the flow rate.
- Ensure adequate ventilation. Avoid sucking in the heated exhaust air also of adjacent units. Maintain minimum distances.

Operator-side measures electrical connection

- Have the electrical connections be made by a licensed electrician.
- Follow the VDE as well as local regulations, in particular the safety regulations.
- Compare the voltage indicated on the motor plate with the operating voltage. The power supply properties must match the specifications on the nameplate.
- Install a motor protection switch.
- Use a motor suitable for frequency converter operation.
- Use a dU/dt filter to avoid voltage spikes or a motor with reinforced windings.

Operator-side measures flushing

- Always connect the flushing lines such that supply for flushing is always ensured.
- Ensure that flushing fluid is supplied even when checking the motor's direction of rotation.
- Ensure that the flushing pressure does not exceed 0.2 bar / 2.9 psi.
- Provide for lost flushing.

Operator-side measures vertical pump installation

- Fasten pump with suitable heavy-duty anchors. The pump tends to tip over due to the elevated centre of gravity.
- Position the pump part always below the motor. If leakage occurs, the liquid cannot ingress into the motor.

Spatial requirements with horizontal set-up

If pumps are set up horizontally, observe the following minimum clearances.

Pay attention to motor performance.

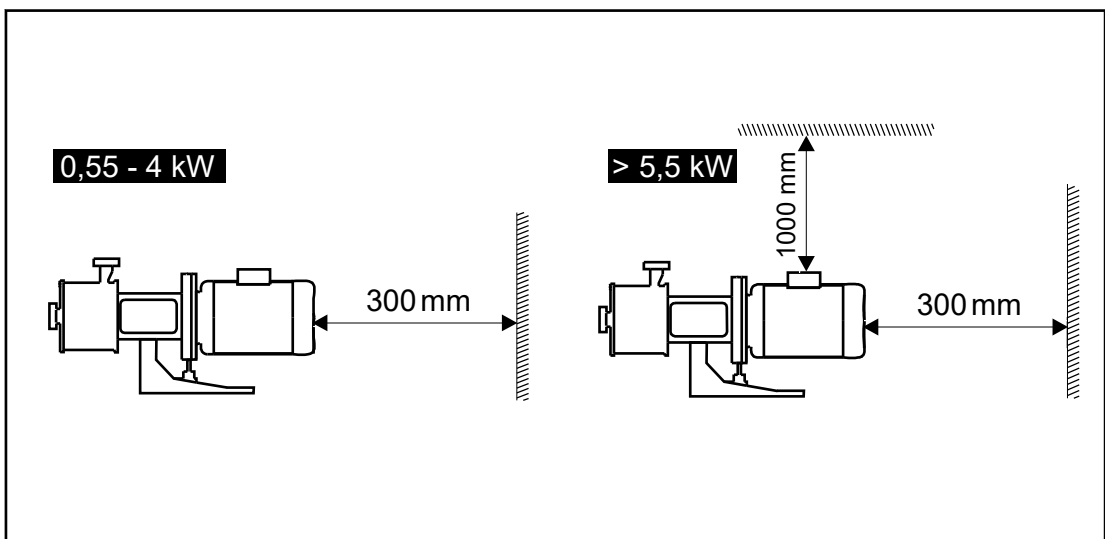

Figure 5-1 - Minimum clearances with different motor sizes

5.1.1 Reducing noises and vibration

Foundation and vibration absorbers

To achieve optimum performance and to minimize noise and vibration, it is recommended to provide the pump with vibration absorbers. In general, this should always be considered for pumps with motor sizes starting from 11 kW (15 hp).

But unwanted vibrations and noises occur also with smaller motor sizes. Noise and vibration are caused by the rotating parts in the motor and the pump and by the flow in the pipes and fittings. The effect on the environment is subjective and depends largely on the correct installation and the nature of the rest of the system.

Vibration damping is best achieved if the pump is set up on a flat, solid concrete foundation. As a guideline, the concrete foundation should be 1.5 times as heavy as the pump.

To avoid the transmission of vibrations to the building, it is recommended to disconnect the pump foundation from parts of the building using vibration absorbers.

Selecting the correct vibration absorber requires the following data:

- Forces transmitted via the vibration absorber.
- Motor speed, taking a speed control into account if appropriate.
- Required damping in % (suggested value: 70%).

The correct damper depends on the respective installation. An incorrectly designed damper may even increase the vibration. Vibration absorbers should therefore be designed by the vendor of the vibration absorber.

Compensators

If the pump is mounted on a foundation along with vibration absorbers, be sure to install compensators at the pipe connections. This prevents the pump from “hanging” in the connections.

Compensators are installed to

- absorb expansion/shrinking in the piping caused by varying fluid temperatures.
- reduce mechanical stress occurring in conjunction with pressure surges in the system.
- absorb noise caused by the system in the piping (only rubber ball compensators).

Compensators must not be used to compensate for inaccuracies in the piping, for example, to compensate for an offset in the centre of the connections.

Install the compensators both on the suction side and pressure side at a minimum distance to the pump, which is 1-1.5 times the nominal diameter of the piping. This allows for an improved flow on the suction side of the pump, as well as reduced pressure drop on the pressure side.

For connections with a size over DN 100 (4"), we always recommend compensators with length limiters.

The pipes must be supported in such a way that they cannot cause strain in the compensators and in the pump. Follow the manufacturer's instructions and hand them over to the person responsible or to the plant manufacturer.

Vibration may cause the following damage:

- Damage to roller bearings of pump and motor
- Damage to the mechanical seal
- Increased coupling wear
- Damage to shaft/hub connections
- Cracks on pump ports
- Loosening of screw connections
- Cable breaks in the motor connection
- Contacting of pump impellers

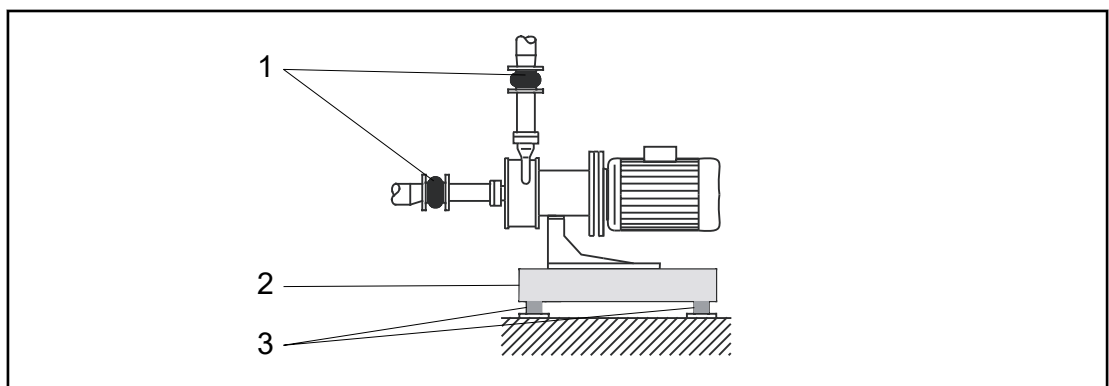

Figure 5-2 - Installation of vibration absorbers

Position	Description	Position	Description
1	Compensators	3	Vibration absorber
2	Solid base		

5.2 Assembly preparations

Unpacking and checking the scope of delivery

Prerequisites

- None

1. Remove transport packaging.
2. Remove all the plastic films and caps at the connections.
3. Check delivery for completeness in accordance with the packing list.
4. Check delivery for possible property damage.
5. Dispose of packaging material in accordance with the pertinent regulations.

⇒ The pump has been unpacked and scope of delivery checked.

Checking smooth running of the impeller

Prerequisites

- The pump has been removed from the packaging and is ready and easily accessible.

Tools

- Screwdriver, spanner

1. Remove motor shroud (if appropriate).
2. Remove the motor fan cover.
3. Heed the direction of rotation of the pump (arrow).
4. Carefully rotate the shaft of the impeller. The shaft should be easy to rotate. If the impeller rubs against something, it has some damage that may have happened during transport of the pump. If the impeller rubs, contact GEA Hilge Customer Service.
5. If the impeller is rotating freely: attach the motor fan cover again.
6. Attach the motor shroud (if appropriate).

⇒ The impeller has been checked for running smoothly.

5.3 Set-up, assembly, connection

Setting up and aligning

Responsibility

- Customer specialist

Prerequisites

- *5.1 Requirements on the place of use* are fulfilled.

Tools

- Machine spirit level
- Spanner
- Fastening material (if appropriate)

1. Note the permissible type of set-up. The pump is designed for horizontal and vertical operation.

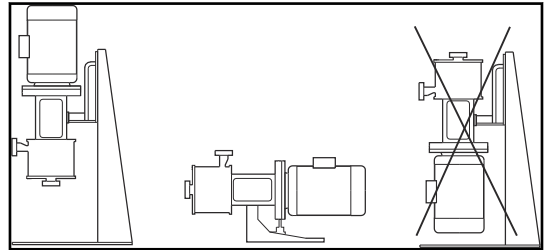

Figure 5-3 - Permissible set-ups of the pump

2. Level the unit via the machined planar surfaces of the ports using a machine spirit level.
 3. Tighten the fastening screws evenly crosswise (where applicable).
- ⇒ The pump has been set up and aligned.

5.3.1 Installation in the piping system

Installation in the piping system

Responsibility

- Customer specialist

Prerequisites

- The pump is free of packaging material.
- Transport covers have been removed from suction port and discharge port.

1. Install the pump in the pipeline according to type of operation (gravity feed mode / suction mode), note *Operator-side measures feed line and discharge line, page 33*

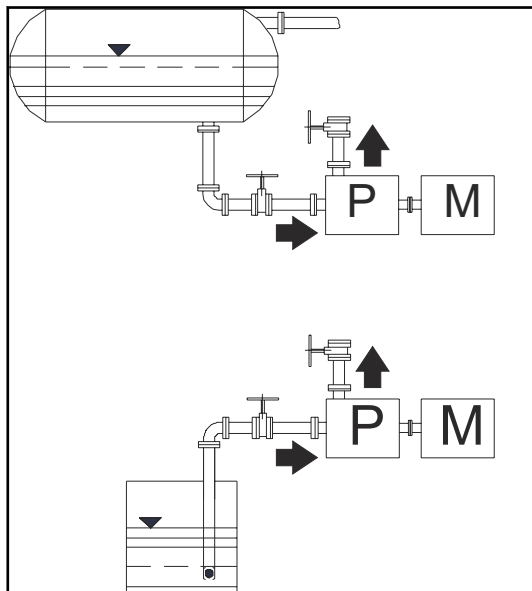

Figure 5-4 - top: gravity feed mode | bottom: suction mode | P - pump | M - motor

⇒ The pump has been installed in the pipeline.

5.3.2 Connecting the flushing

Dry running of the mechanical seal

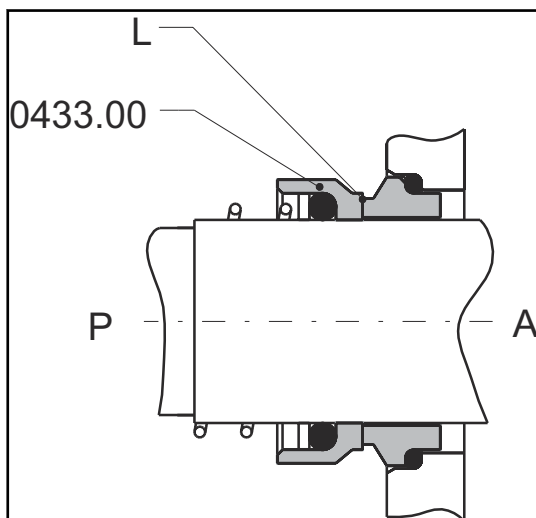

Figure 5-5 - Single-acting mechanical seal

For correct sealing, the mechanical seal (0433.00) requires a lubricant film (L) between the sliding surface on the atmosphere side (A) and product side (L). If the lubrication film is missing or interrupted between the sliding surfaces, dry running occurs. The friction heat generated by the direct contact of the sliding surfaces leads to the destruction of the mechanical seal. Depending on the material pairing, this can take place within a few seconds.

5.3.2.1 Quench version (optional)

Pre-requisites for quench operation

HILGE pumps with quench seal are equipped with a lip seal. The pressureless flushing fluid is located between the mechanical seal and the lip seal.

The following conditions must be fulfilled for quench operation:

- The supply of the mechanical seal with flushing fluid must be unpressurised. The maximum overpressure must not exceed 0.2 bar.
- When using pass-through flushing, secure the flushing fluid port with a pressure reducer or the like if necessary.
- When using a closed flushing circuit with a supply reservoir, regularly monitor the fill level (visually or by means of level probes).
- Make sure that no pressure build-up can occur in the flushing circuit. Keep the reservoir open to the atmosphere.
- For critical media, regularly change the flushing fluid.
- The maximum temperature of the flushing fluid must be 20 K below the boiling temperature of the flushing fluid at the outlet.
- The temperature rise in the pump flushing chamber is normally less than 10 K (inlet/outlet).
- The maximum permissible operating temperatures of the flushing device must not be exceeded.

Connecting quench flushing (optional)

Responsibility

- Customer specialist

Prerequisites

- Connections for connecting the flushing are fulfilled.

Tools

- Spanner

1. Connect the discharge line (A).

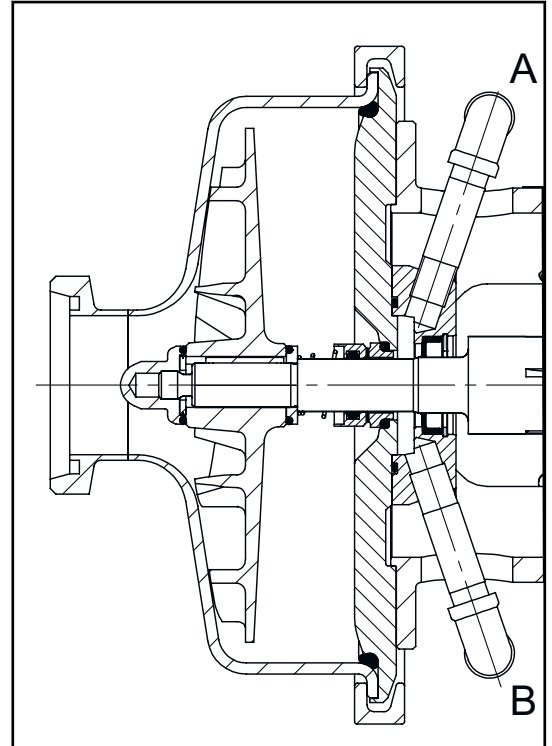

Figure 5-6 - Connections for flushing

Position Description

- | | |
|---|----------------|
| A | Discharge line |
| B | Feed line |

2. Connect the feed line (B).
 3. Check that the connections are firmly in place. In the event of a leakage, tighten the connection, replace seal if necessary.
- ⇒ The flushing system has been connected.

Requirements on the flushing fluid

The flushing fluid has the task to lubricate and cool the product-side mechanical seal and the shaft seal on the atmospheric side.

The flushing fluid must meet the following criteria:

- Good flowability
- No impurities
- No solids
- No dissolved components
- Adequate thermal conductivity
- No chemical or mechanical corrosion of the pump materials, sealing materials, and elastomers used
- No contaminating of the pumped fluid
- Viscosity < 5 mPas
- Water hardness < 5° dH

Demineralised water meets these requirements to a large extent.

5.3.3 Connecting the pump to the power supply

⚠ DANGER

Live parts

Electrical shocks can cause serious personal injuries or death.

- Only allow properly qualified staff to work on the electrical equipment.
- Prior to establishing electrical connections, check the maximum permissible operating voltage.

⚠ DANGER

For motors with frequency inverter (tronic): Electric shock by touching live parts!

Electrical shock can result in serious personal injury or death.

- Even if the power supply is switched off, touching electrical parts may cause an electric shock.
- Disconnect the power supply and wait at least four minutes before touching electrical components.

5.3.3.1 Operator-side pre-requisites equipotential bonding

Earthing the motor

Equipotential bonding for the motor is performed via the protective conductor connection in the terminal box.

Earthing the machine pad support

Prerequisites

- The pump is ready for connection.

Tools

- Toothed lock washer
- Earth cable
- Spanner

1. Screw the earth cable to position (B).
Use a toothed lock washer.

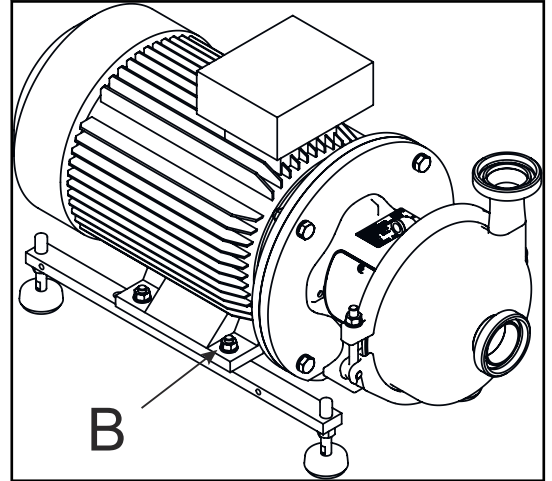

Figure 5-7 - Connection for the earth cable

2. Connect the earth cable to the earth conductor.
⇒ The equipotential bonding of the machine pad support is established.

Earthing the motor shroud

Prerequisites

- The pump is ready for connection.

Tools

- Toothed lock washer
- Earth cable
- Spanner

1. Use the bore hole (A) provided to connect the earth cable on the side of the motor shroud.

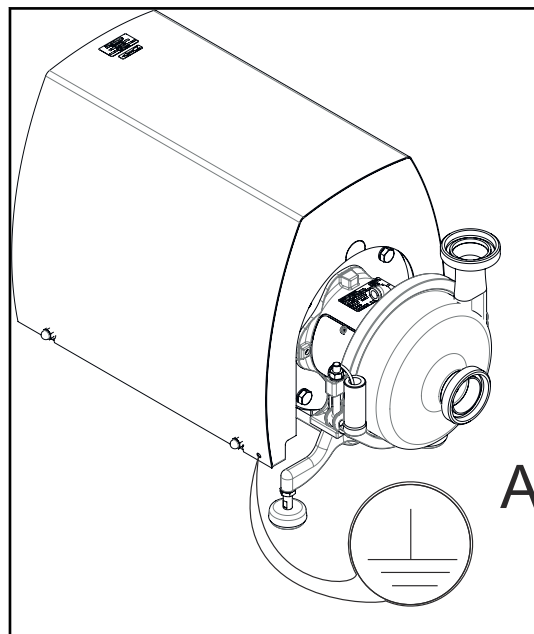

Figure 5-8 - Connection for the earth cable

2. Connect the earth cable to the earth conductor.
⇒ The equipotential bonding of the motor shroud is established.

Connecting the pump to the power supply

Responsibility

- Trained customer specialist

Prerequisites

- Conditions for connecting the pump to the power supply are fulfilled.
- The pump has been earthed in accordance with the specifications in this operating manual.

Tools

- Spanner
- Screwdriver

1. Please note the order data and prescribed connection voltage.
2. Connect the pump in star circuit.

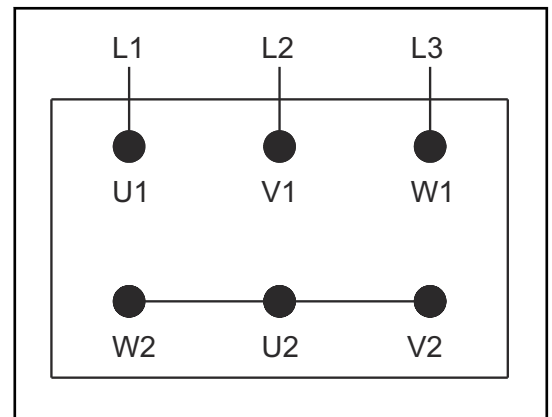

Figure 5-9 - Connection diagram for star circuit

3. Connect the pump in delta circuit.

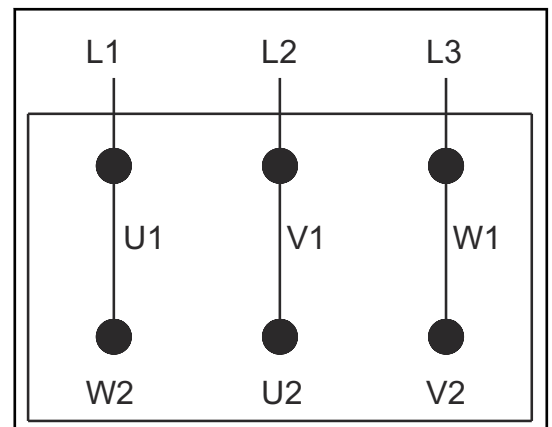

Figure 5-10 - Connection diagram for delta circuit

⇒ The pump is connected to the power supply.

Checking the direction of rotation after connecting

Responsibility

- Trained customer specialist

Prerequisites

- The pump has been connected to the power supply.
- All safety devices have been installed.
- All hydraulic connections have been checked for a firm fit.
- The pump is earthed.

Tools

- Screwdriver, spanner

1. Open check valves.
2. Fill the pump (system).
3. For double mechanical seal / quench version, connect the flushing fluid.
4. Note the direction-of-rotation arrow on the pump.
5. Switch on the motor briefly (1-2 seconds).
6. Compare the direction of rotation with the specified direction (arrow).
7. If the direction of rotation does not correspond to the specified one, correct the electrical connections.

⇒ The direction of rotation has been checked and corrected if necessary.

5.3.3.2 Connecting frequency inverter

All three-phase motors can be connected to a frequency converter. Frequency converter operation may subject the insulation of the motor to a higher load so that louder motor noise than in the normal case may occur due to eddy currents caused by voltage spikes.

Large motors driven by a frequency converter are loaded by bearing currents. For pump motors that are used with an external frequency converter, HILGE recommends the use of insulated motor bearings for sizes of 37 kW and above to avoid increased wear of the motor bearings by possible bearing currents.

Check the following operating conditions if the pump is operated using a frequency converter:



Incorrect operation of the frequency converter

Follow the manufacturer's instructions for the installation and operation of a frequency converter.

Operating conditions	Measures
Noise-sensitive applications	Install a dU/dt filter between the motor and frequency converter (reduces voltage spikes and thus noise).
Particularly noise-sensitive applications	Install sinusoidal filter.
Cable length	Use a cable which satisfies the conditions prescribed by the manufacturer of the frequency converter.

Operating conditions	Measures
Supply voltage up to 500 V	Check that the motor is suitable for frequency converter operation.
Supply voltage between 500 V and 690 V	Install a dU/dt filter between the motor and the frequency converter (reduces voltage peaks and thus noise), or check whether the motor has a reinforced insulation.
Supply voltage 690 V and above	Install a dU/dt filter between the motor and the frequency converter and check whether the motor has a reinforced insulation.

6 Commissioning

This chapter contains information for initial start-up and every recurring start-up of the pump. In addition, this chapter describes the checks and tests to be performed during this. The target group for this chapter are all those who carry out actions at the pump in this context.

INFO Observe chapter 2 *Safety* for every start-up.

6.1 Preparing commissioning

6.2 Operating conditions

Checking conditions of use

Compare the information of the following documents with the pump's intended conditions of use:

- Pump data sheet (order documents)
- Nameplate
- Operating manual
- Test bench acceptance
- Make sure that the pump is operated only under the specified conditions of use. These conditions apply to pressure, temperature and pumped medium, for example.
- Carry out a cleaning cycle before the first start-up or after conversion of the pump.
- Make sure there are no foreign objects in the pump.

6.3 Initial start-up

Initial start-up of the pump

Responsibility

- Operating staff

Prerequisites

- All connections have been checked for a firm fit.
- All safety devices have been installed.
- The electrical connections are correct.
- The pump and the system-side pipe system have been cleaned.

Tools

- Screwdriver, spanner

ATTENTION

Fast increase and pressure and heating due to pumping against a closed shut-off valve

Pumping against a closed shut-off valve can cause damage to the pump.

- Open the shut-off valve after 30 seconds at the latest.

1. Open check valves in the system.
2. Fill the pump along with the system.
3. Vent the pump along with the system.
4. With flushed mechanical seal, connect the flushing liquid. Start flushing to prevent dry running.
5. Fully open the suction-side check valve.
6. Close the pressure side check valve.
7. Switch on the pump.
8. Slowly open the pressure side check valve.

⇒ Initial start-up is completed.

INFO If the head does not rise after the pump has been switched on, switch the pump off, vent it again and repeat the work steps in section *Initial start-up of the pump*.

Functional testing of the mechanical seal

INFO An intact mechanical seal operates virtually without any leakage. If pumped or flushing medium leaks out, switch the pump off and replace the mechanical seal (have the seal replaced).

Responsibility

- Operating staff

Prerequisites

- The pump has been started-up.

1. Inspect the pump and check whether liquid is escaping at the mechanical seal.

⇒ The function of the mechanical seal has been checked.

Function test of the shaft seal (quench)

INFO An intact shaft seal effectively separates the pumped liquid from the flushing liquid. If there is pumped medium in the flushing liquid, switch the pump off and replace the shaft seal (have the shaft seal replaced).

Responsibility

- Operating staff

Prerequisites

- The pump has been started-up.

1. Observe the draining flushing fluid and check if it is saturated with pumped medium.

⇒ The function of the shaft seal has been checked.

6.4 Restarting

Following temporary decommissioning

Temporary decommissioning includes putting out of operation for maintenance and repair work.

The pump can be put back into operation after temporary decommissioning without additional measures, see *6.3 Initial start-up*.

6.5 Monitoring operation

Dangerous situations during operation can be avoided by safety-conscious and proactive behaviour of the personnel.

For operation, the following principles apply:

- Monitor the pump during operation.
- Do not modify or disassemble safety devices or put them out of operation. Check safety devices at regular intervals.
- All guards and hoods must be fitted as intended.
- The installation location of the pump must always be properly ventilated.
- Structural changes to the pump are not permitted. Report any change to the pump immediately to the person in charge.

6.6 Shutdown

Shutdown

Responsibility

- Operating staff

Prerequisites

- The pump and valves are freely accessible.

1. **CAUTION** Pressure surge

A pressure surge can cause damage to the pump and system.

- Always close shut-off valves slowly.

INFO

A pressure surge is a sudden increase in pressure in the system. This pressure increase may be triggered by quickly shutting off the flow in the pressure pipe, in addition to other causes. If a pressure surge occurs, the maximum permissible pump pressure is much higher for a short time.

Close the pressure side shut-off valve.

2. Switch off the pump.
 3. Close the suction side shut-off valve.
 4. Switch off the flushing.
 5. Make sure that the pump is depressurised.
- ⇒ The pump has been shut down.

7 Cleaning

This chapter contains information about cleaning the pump. In addition, this chapter provides information about cleaning intervals and the use of cleaning agents. The target group for this chapter are all those who carry out actions related to cleaning at the pump.

INFO For all cleaning, observe chapter 2 *Safety* of this document.

7.1 General points

To ensure the quality of sensitive fluids, pumps must be cleaned immediately after each use. Only in this way will adhesions and deposits be removed completely and contamination of the products be prevented. To achieve the best possible results, Hilge pumps are optimised with regard to gap and dead spaces, designed according to DIN EN 13951, and resistant to the cleaning agents referred to in the following chapter. Cleaning is carried out inside the system; no parts need to be removed or dismantled.

In general, a distinction is made between CIP and SIP. The procedures must comply with the state of the art and the EC directives. In any case, the operator must ensure that the target specifications are reached and applied as intended using the cleaning and sterilisation procedures, as well as the working temperatures and steps.

7.2 CIP cleaning

CIP stands for Cleaning in Place, the pump is completely rinsed with cleaning agents. During CIP cleaning, run the pump at a flow speed of at least 1.5 m per second. Carry out total drainage via VTV valve or by turning the discharge port downwards.

The cleaning agent used must be suitable for the respective cleaning task.

The following table lists approved detergents and disinfectants and their permitted concentrations. Alternatively, information from DIN11483 Part 1 can be used.

Cleaner type	Chemical designation	Max. concentration [%]	Max. temperature [°C] (°F)	Permissible pH	Max. permissible Cl content in the preparation water [mg/l]	Max. permissible contact time [h]
Alkaline	NaOH	2.50%	85 (185) ²	13-14	150	3
Acid	H2SO4	2% ³	60 (140)		150 ³	1
Acid	H3PO4, HNO3					

2) Depends on the maximum permissible temperature of the pump

3) CrNi steels and CrNiMo steels

Cleaner type	Chemical designation	Max. concentration [%]	Max. temperature [°C] (°F)	Permissible pH	Max. permissible Cl content in the preparation water [mg/l]	Max. permissible contact time [h]
Acid	C2H4O3	0.01%	90 (194)		150	0.5
Acid	C2H4O3	0.15%	20 (68)		150	2
Acid	Iodophore	50 mg/l act. Iodine	30 (86)	>3	150	3

Cleaning agents that contain hydrochloric acid (HCl) or hydrofluoric acid (HF) must not be used. Consult the supplier for the use of special cleaning agents and procedures with respect to the materials. Thoroughly rinse the pump with water to remove any cleaning agents leaving no residues. The maximum permissible temperatures can be found in chapter 3.4.7 *Operating temperatures*.

7.3 Cleaning at standstill

Manual exterior cleaning

INFO Regular manual external cleaning of the pump unit facilitates proper operation. Dry cleaning is preferable to wet cleaning. The cleaning intervals depend on the degree of contamination. Rinse with clear water when aggressive cleaning agents are used.

Prerequisites

- The pump has been shut down.

Tools

- Soft cloth or brush
- Cleaning agents

1. Ensure the tightness of the motor (terminal box, condensation holes).
2. **ATTENTION** Danger due to high-pressure water jet
Cleaning with a high-pressure cleaner can cause damage to the pump.
 - Only wipe the pump down or rinse it off without pressure.

Clean the outside of the pump with a soft cloth or brush and use warm water if necessary.

3. Vent the pump along with the system.
4. Remove dust and debris that may clog the fan and cooling fins of the engine.

⇒ Manual exterior cleaning is completed.

8 Maintenance

This chapter contains information about the maintenance, inspection and repairs of the pump. The target group for this chapter are all those who carry out actions at the system in this context.

INFO During all maintenance actions, observe chapter 2 *Safety* of this document.

8.1 Maintenance and inspection

 WARNING
<p>Danger to life due to unauthorised or uncontrolled restart! Unauthorised or uncontrolled restart can lead to serious injuries or even death.</p> <ul style="list-style-type: none"> ● During all work on the system: make sure that the system is secured against unauthorised or uncontrolled restart. ● Secure actuation device with a lock. ● In the case of pumps with trolley, disconnect the mains plug and fasten it to the trolley in such a way that it is visible for maintenance personnel. ● After completing work on the system: make sure that there is no-one still in the danger zone before the system is switched back on.

Measures to secure against unintentional restart

- Keep removed mains plugs, circuit breakers or fuse inserts in a safe place and replace them by blocking plugs or dummies.
- Disconnect circuit breakers, switch cabinet or fuse box and keep the key to the lock in a safe place.
- Attach suitable signs prohibiting switch-on or warning signs.

To prevent any faults and guarantee maximum operational safety of the pump, GEA recommends the following inspection and maintenance work.



Hygiene risk, food safety

Worn out and not fully functional components may lead to the contamination of the pump. Pay close attention to the condition of the O-rings during regular inspections.

Component / assembly	Measure	Interval	Qualifications
Mechanical seal O-rings	Replace	When used in media with temperatures 60 °C to 130 °C (140 °F to 266 °F): after 2,000 operating hours or three months When used in media with temperatures < 60 °C (< 140 °F): after 9,000 operating hours or 12 months. Independently of the period of use, O-rings must be replaced if the following properties are indicated: <ul style="list-style-type: none"> • The O-ring is deformed at one or more locations. • The O-ring has cracks. • The surface of the O-ring is porous and brittle. • The O-ring has lost its elasticity. 	Trained customer specialist
Clamp shaft Pump casing	Check screw connection, tighten if nec.	Monthly	Customer specialist
Motor, where appropriate	Relubricate	On motors with grease nipple, the specifications for relubrication, type of grease, grease quantity, and other information as applicable are given on the lubrication or nameplate.	Customer specialist
Pump	Visible inspection for tightness and correct function	During every operation / every start-up	Operator

8.1.1 Maintenance jobs

Replace O-rings

INFO The O-rings should be replaced every time the pump is disassembled.

Prerequisites

- Access to the pump
- The pump is at a standstill and secured against restart.

1. Disassemble the pump. See *8.2 Disassembly*.
2. Replace O-rings. The position of the different O-rings can be seen in *Parts overview pump part*.
3. Assemble the pump.

⇒ The O-rings have been replaced.

Replace the mechanical seal

Prerequisites

- Access to the pump
- The pump is at a standstill and secured against restart.

1. Disassemble the pump. See *8.2 Disassembly*.
2. Replace the mechanical seal.
3. Assemble the pump. See *8.3.5 Installing single mechanical seal* or *8.3.6 Installing the single encapsulated mechanical seal*.

⇒ The mechanical seal has been replaced.

Tightening screw connection of the clamp shaft

Prerequisites

- Access to the pump
- The pump is at a standstill and secured against restart.

Tools

- Spanner

1. Tighten the screw connection of the clamp shaft cross-wise, heed torques on page 26.

⇒ The screw connection of the clamp shaft is tightened.



Observe the motor manual

Hazard if the operating manual is not read before actions at the motor.

Lubricating the motor

INFO Observe the motor operating manual.

Motors without grease nipple

Motors without grease nipple are equipped with lifetime lubrication. How long grease can be used depends on the temperature and determines the service life of the bearings. Prerequisite is that the motor must be used according to the specifications in the catalogue.

Motors with grease nipple

On motors with grease nipple, the specifications for relubrication, type of grease, grease quantity, and other information as applicable are given on the lubrication or nameplate.

8.2 Disassembly

Disassembly of the pump is carried out in the reverse order of assembly. For this purpose, obtain the work steps from the respective sections in the chapters *8.3 Assembly*.

Pre-requisites for disassembly:

- The pump has been disconnected from the power supply.
- The pump is depressurised.
- The pump has cooled down.
- The pump has been secured against being switched on unintentionally.
- If hazardous media have been pumped, the pump has been decontaminated.

Tools from the GEA Hilge assembly tool kit make disassembly easier and avoid damage to the pump, see page 59.

8.2.1 Removing the shaft sleeve

Possibilities for removing the shaft sleeve

Responsibility

- Customer specialist

Prerequisites

- The pump has been disassembled.

Tools

- Device for heating the shaft sleeve
- Side cutter
- Hammer

1. Heat the shaft sleeve and pull it off the shaft.
2. Overcome the predetermined tear line towards the sleeve through a jerky movement of a side cutter.
3. Remove the shaft sleeve. Light blows with the mallet peen across the width of the sleeve widen it so that it can be removed easily.

⇒ The shaft sleeve has been disassembled.

8.3 Assembly

Assembly tool kit

Tools from the GEA Hilge assembly tool kit prevent damage to the mechanical seal during assembly.

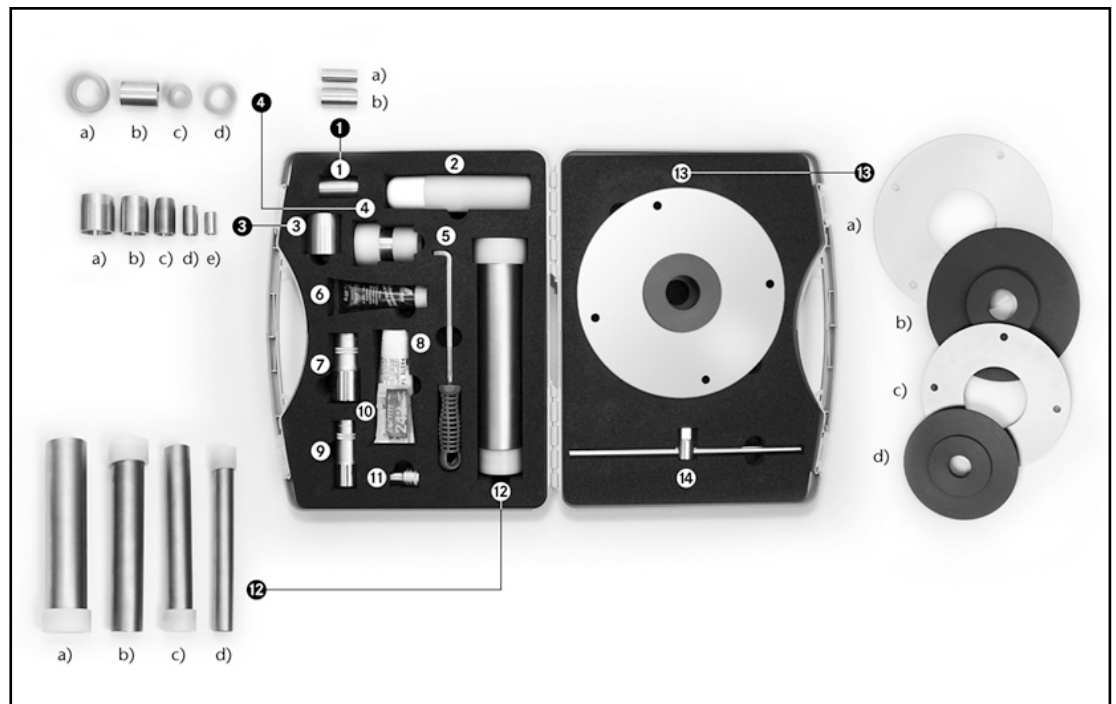

Figure 8-1 - Tools in the GEA Hilge assembly tool kit

Contents and use

Image position	Designation	GEA Hilge HYGIA I	GEA Hilge HYGIA II
1a	Mounting sleeve Ø 19	•	
1b	Mounting sleeve Ø 28		•
2	Spray bottle	•	•
5	Extractor for mechanical seal counter ring	•	•
6	Klüber paste UH1 96-402	•	•
7	Socket wrench a/f 32		•
7	Socket wrench bit a/f 27		•
8	Optimol paste TA	•	•
9	Socket wrench a/f 24	•	
9	Socket wrench bit a/f 17	•	
10	Screw locking compound Loctite Type 243	•	•
12c	Mechanical seal mounting sleeve Ø 28 and Ø 30		•

Image position	Designation	GEA Hilge HYGIA I	GEA Hilge HYGIA II
12c	Plastic adapter Ø 28		•
12d	Mechanical seal mounting sleeve Ø 19 and Ø 22	•	
12d	Plastic adapter Ø 19	•	
14	T-handle with 1/2" square	•	•
	Complete assembly tool kit	•	•

Parts overview pump part

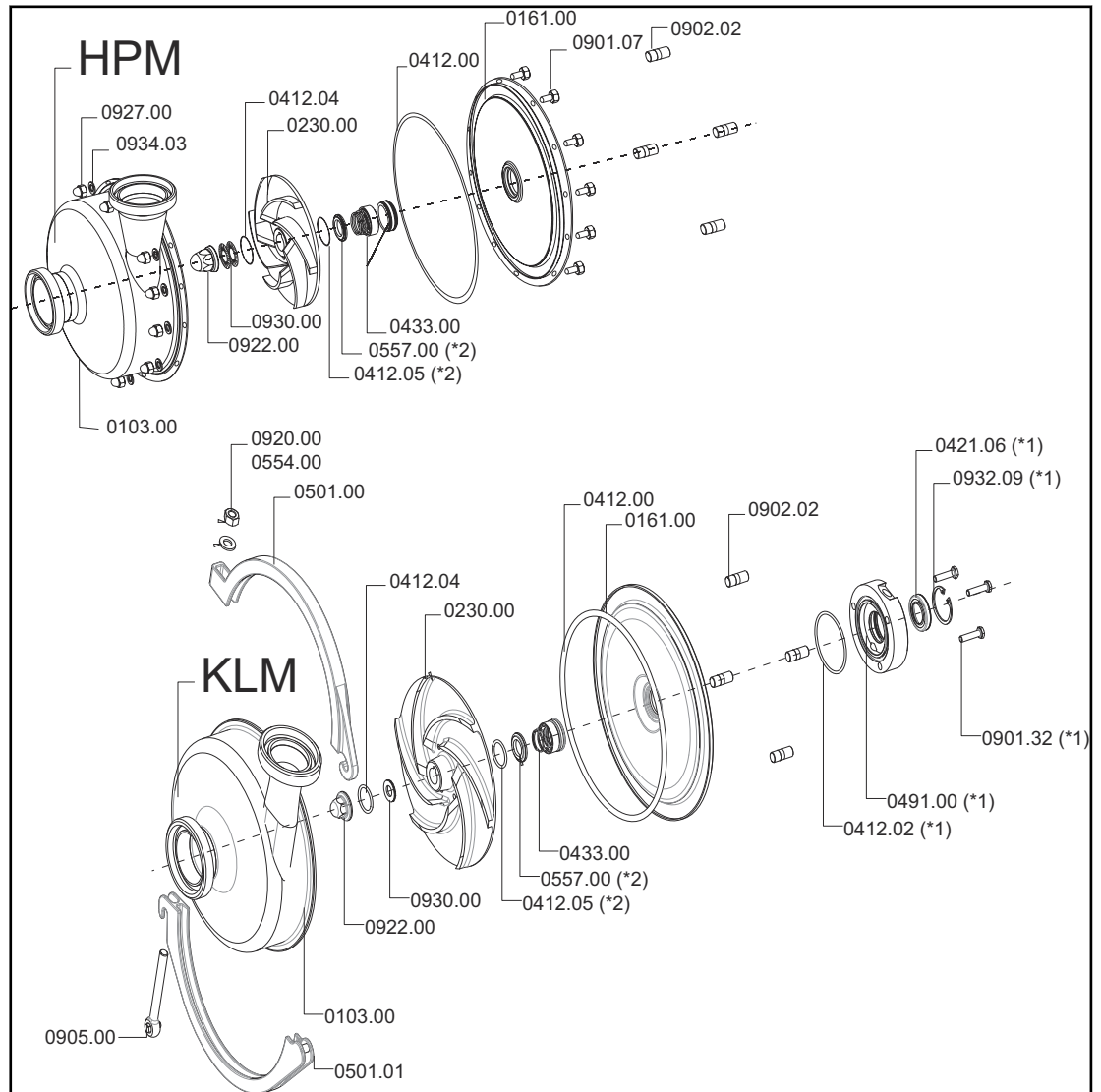

Figure 8-2 - Parts overview with different casing variants | *1: only with flushed seal

Pcs.	Part number	Designation	Pcs.	Part number	Designation
1	0103.00	Annular casing	1	0554.00	Washer
1	0161.00	Back plate	1	0557.00	Seal spacer
1	0230.00	Impeller	12	0901.07	Hex screw
1	0412.00	O-ring seal	3	0901.32	Hex screw
1	0412.02	O-ring seal	4	0902.02	Stud bolts
1	0412.04	O-ring seal	1	0905.00	Connecting screw
1	0412.05	O-ring seal	1	0920.00	Hexagon nut
1	0421.06	Shaft seal	1	0922.00	Impeller nut
1	0433.00	Mechanical seal	12	0927.00	Cap nut

Pcs.	Part number	Designation	Pcs.	Part number	Designation
1	0491.00	Seal cartridge	1	0930.00	Toothed lock washer
1	0501.00	Clamp ring	1	0932.09	Retaining ring
1	0501.01	Clamp ring	12	0934.03	Spring washer

Parts overview for K motor stool

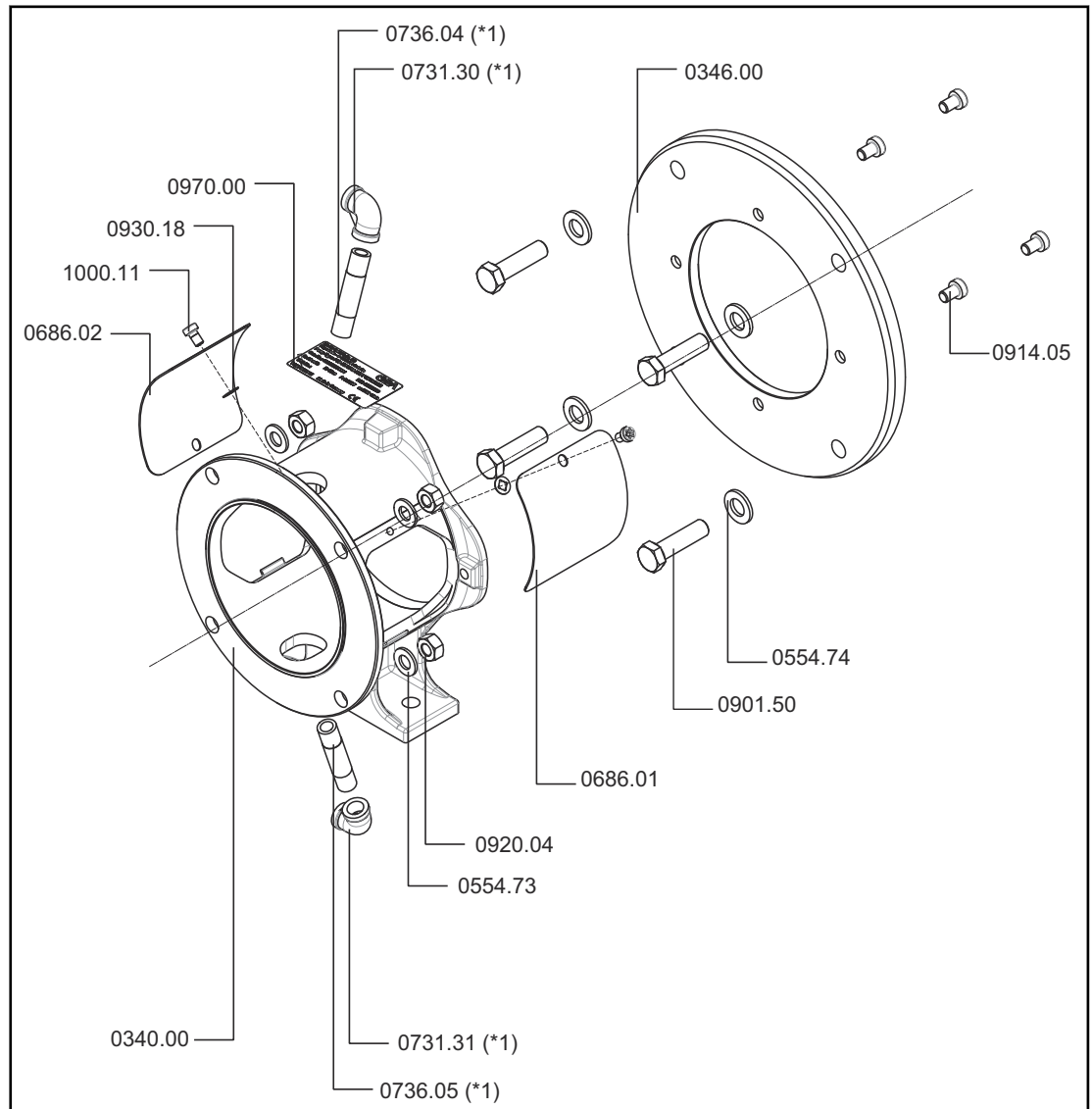

Figure 8-3 - Parts overview for K motor stool

Pcs.	Part number	Designation	Pcs.	Part number	Designation
1	0340.00	Motor stool	1	0736.04	Pipe
1	0346.00	Intermediate motor stool	1	0736.05	Pipe
4	0554.73	Washer	4	0901.50	Hex screw
4	0554.74	Washer	4	0914.05	Hex socket screw
1	0686.01	Protective guard	4	0920.04	Hexagon nut
1	0686.02	Protective guard	2	0930.18	Retaining ring
1	0731.30	Elbow connector	1	0970.00	Nameplate
1	0731.31	Elbow connector	2	1000.11	Screw

Parts overview of drive

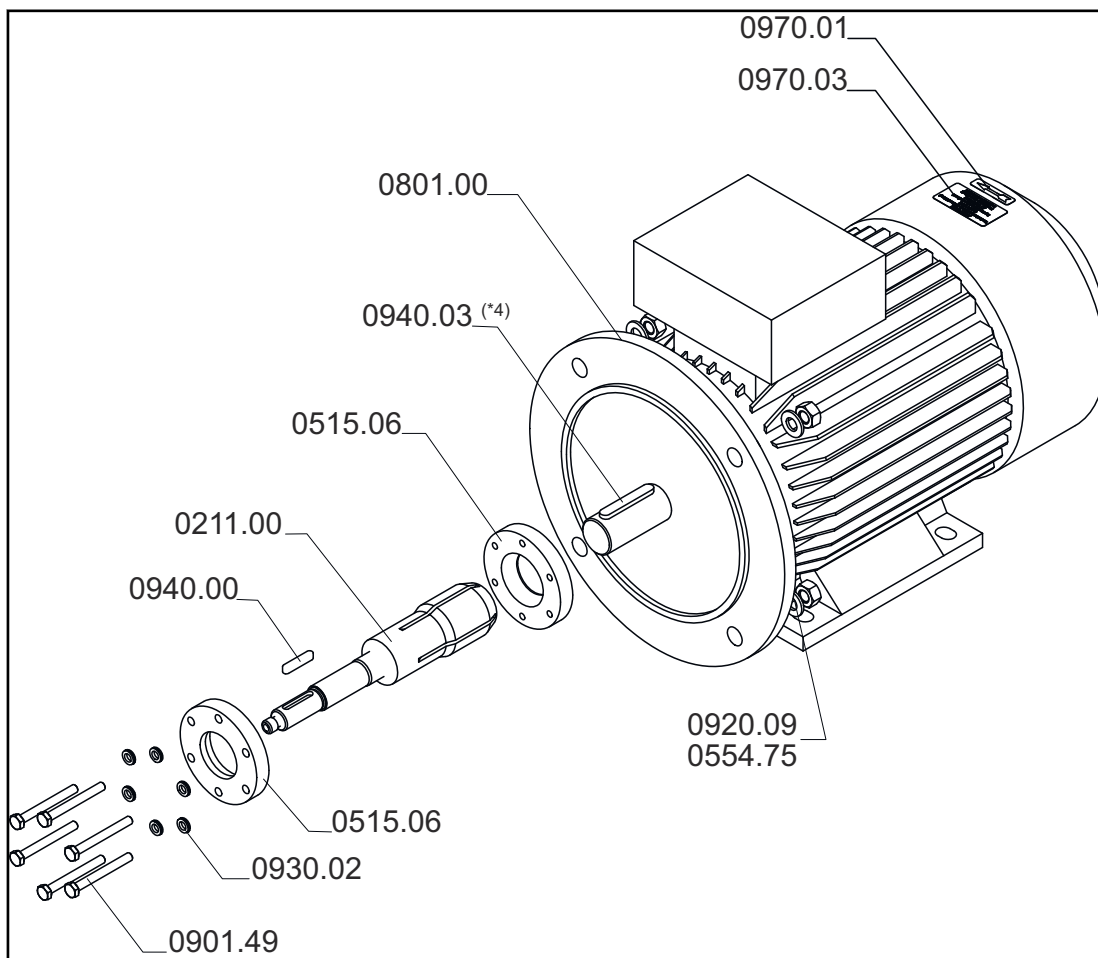

Figure 8-4 - Overview of the drive parts

Pcs.	Part number	Designation	Pcs.	Part number	Designation
1	0211.00	Shaft	6	0901.49	Hex head screws
1	0515.05	Clamping ring	4	0904.20	Grub screw
1	0515.06	Clamping ring	4	0920.09	Hexagon nut
4	0554.02	Washer	4	0920.12	Hexagon nut
4	0554.50	Washer	4	0920.81	Hexagon nut
4	0554.75	Washer	4	0927.08	Cap nut
2	0592.12	Base	6	0930.02	Retaining ring
4	0592.13	Base	1	0940.00	Key
4	0595.00	Pad	1	0940.03	Key

Pcs.	Part number	Designation	Pcs.	Part number	Designation
1	0680.00	Motor shroud	1	0970.01	Rotation arrow
1	0801.00	Motor	1	0970.02	Rotation arrow
4	0901.02	Hex screw	1	0970.03	Warning label / information label

Parts overview motor shroud

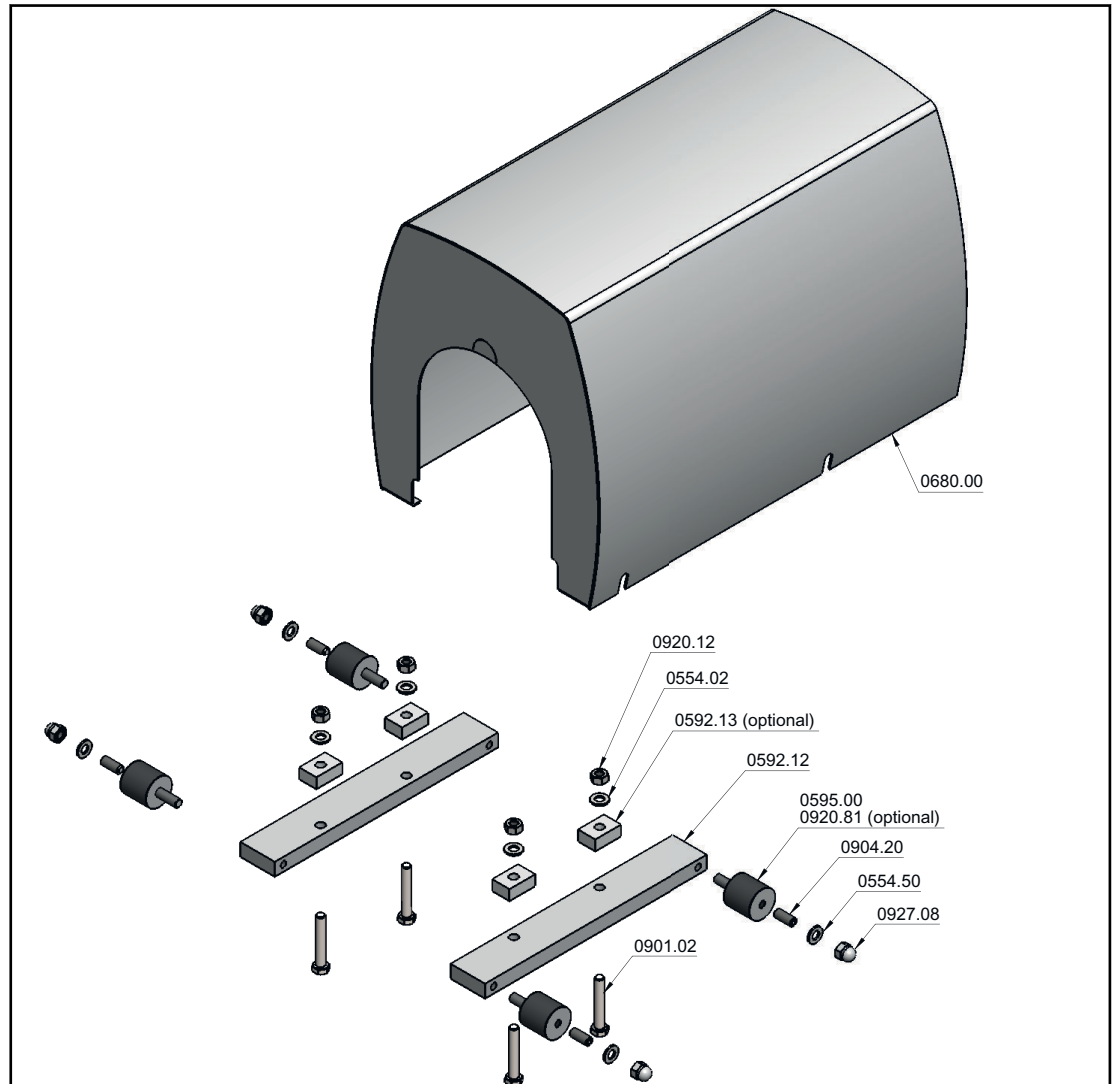

Figure 8-5 - Parts overview motor shroud

Pcs.	Part no.	Designation	Pcs.	Part no.	Designation
4	0554.02	Washer	4	0901.02	Hex screw
4	0554.50	Washer	4	0904.20	Grub screw
2	0592.12	Base	4	0920.12	Hexagon nut

Pcs.	Part no.	Designation	Pcs.	Part no.	Designation
4	0592.13	Base	4	0920.81	Hexagon nut
4	0595.00	Pad	4	0927.08	Cap nut
1	0680.00	Motor shroud			

8.3.1 Installation instructions

INFO

Contaminated components will contaminate the pump and system. Use suitable chemical cleaning agents to remove impurities in the area of the impeller area, the O-rings or the mechanical seal. Use a brush and / or other tools in order not to damage the surface. Plan contact-free cleaning in an ultrasonic bath to clean the mechanical seal.

Always observe the following instructions:

- Use tools from the HILGE assembly tool kit for installation.
- Check removed parts for damage and wear, and replace if necessary. Use only proper, clean parts for installation. Clean installation space and contact surfaces before installation.
- Always use original spare parts.
- Only use certified original spare parts for 3-A applications.
- Use no mineral oil greases for the wet section assembly.
- Always replace mechanical seals completely.
- Observe the properties indicating that replacement of the O-rings is necessary, see *8.1 Maintenance and inspection*.
- Use an impact wrench or an impeller nut mounting device to tighten the impeller nut (0922.00).

ATTENTION

Hygiene risk through contamination of the components

Contaminated components contaminate pump and system and can endanger food safety.

- Use suitable chemical cleaning agents to remove impurities in the area of the impeller hub, enclosed threads of impeller nut and pump shaft, O-rings, pump shaft and mechanical seal, for example
 1. Clean with warm water (approx. 40° C) and a commercially available dishwasher detergent.
 2. Rinse the cleaned parts with hot water (approx. 80 °C) to thoroughly remove bacteria, germs and cleaning agent residues.
- Use a brush and / or other tools without damaging the surface.
- Plan contact-free cleaning in an ultrasonic bath to clean the mechanical seal.

8.3.2 Installing shaft sleeve

Responsibility

- Customer specialist

Prerequisites

- Applies to the flushed mechanical seal, quench.
- The shaft sleeve is used to repair a worn pump shaft, using the original seal size.
- The pump has been disassembled.

Tools

- Assembly set:
 - 1 x shaft sleeve
 - 1 x mounting sleeve
- Extended mounting sleeve or suitable pipe
- Mallet, side cutter, if necessary filler, sandpaper
- Klüber paste

1. Note the fitting position of the shaft seal (0421.06). Use the shaft sleeve (0524.01) only for repairs.

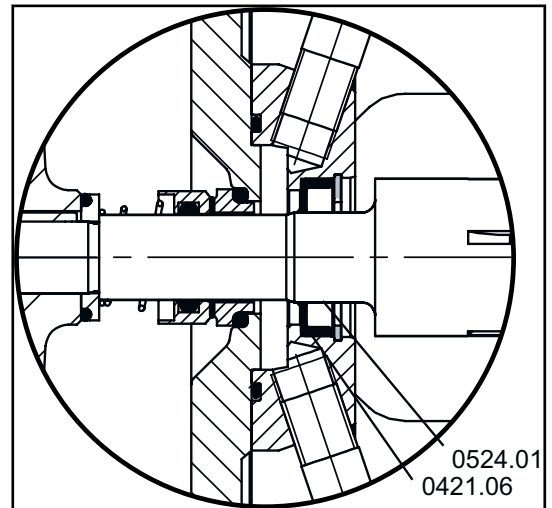

Figure 8-6 - Cutaway view shaft seal

2. Clean the surface of the pump shaft and remove any burrs.
3. Measure the shaft diameter at two or three intact areas of the shaft near the wear location. If the average diameter matches the diameter of the shaft sleeve, the sleeve can be tightly installed.
4. Mark the position of the shaft sleeve on the shaft.
5. If the sealing lip has buried into the shaft, fill the grooves with an epoxy-type filler. CAUTION: Pull the shaft sleeve onto the shaft before the filler cures!
6. Use even strokes against the closed end of the mounting sleeve with the mallet to drive the shaft sleeve up to the marked point. If the length of the mounting sleeve is not sufficient, use an appropriate pipe section.
7. If the collar has to be removed for reasons of space: use a side cutter to remove the collar from the shaft sleeve along the predetermined tear line.
8. Check the shaft once more for burrs and remove them if necessary.

9. Lightly grease the surface with Klüber paste and fit the seal (see manufacturer's operating manual in the assembly set).

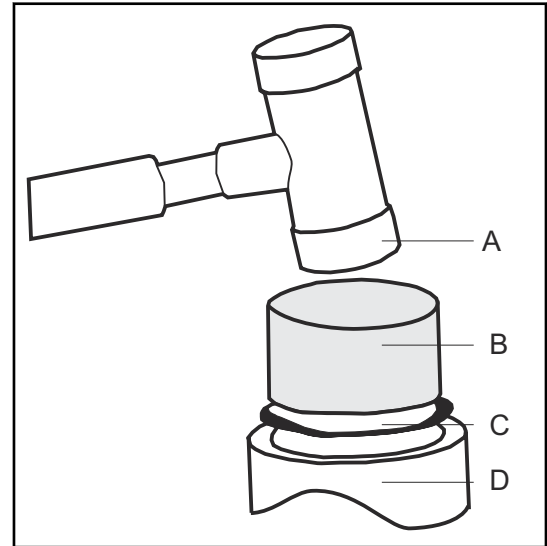

Figure 8-7 - Drive the sleeve with light blows from the mallet onto the shaft

Position Description

A	Hammer
B	Mounting sleeve
C	Shaft sleeve
D	Shaft

⇒ The shaft sleeve has been installed.

8.3.3 Installing the motor, motor stool and pump shaft

Installing the motor, motor stool and pump shaft

Responsibility

- Trained customer specialist

Prerequisites

- The pump has been disassembled.

Tools

- Klüber paste UH1 96-402
- Loctite 243 (medium strength)
- Mounting sleeve (included with the pump)

INFO Unless stated otherwise, the parts listed in these instructions are shown in *Parts overview of drive*.

1. **ATTENTION** Overloading the motor shaft and bearings. Motor shaft and bearings can become damaged.
 - Do not place the pump upright on the fan cover of the motor or install the pump in this position.

Preassemble the clamp connection with clamping rings (0515.05) and (0515.06) and pump shaft (0211.00). Grease the screws with Klüber paste.

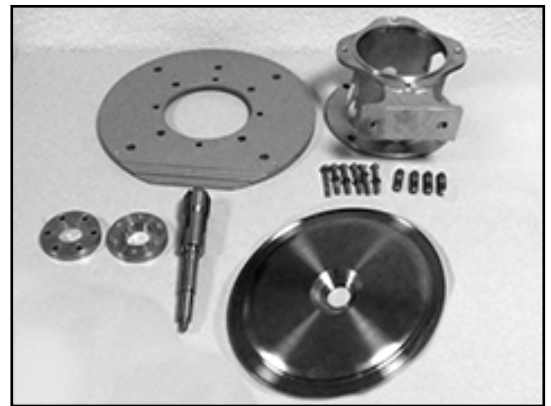
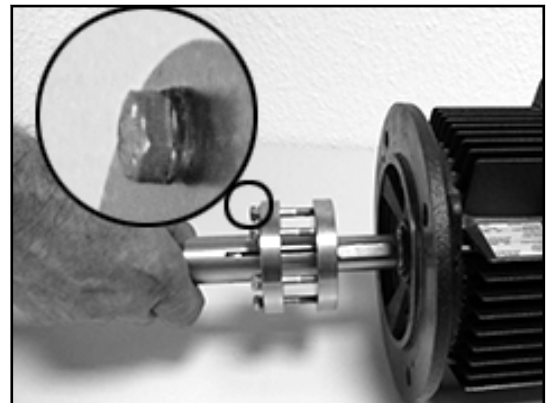

Figure 8-8 - Individual parts for connection of the motor

2. Make sure that the motor shaft is free of grease.
3. Push the pump shaft (0211.00) onto the motor shaft.



4. **INFO**

The work steps 4 to 12 show the assembly of the flushed mechanical seal. For versions with a single mechanical seal (without seal cartridge), continue from work step 13.

Wet lip seal (0421.06) with water and push it into the seal cartridge (0491.00). Use mounting sleeve.

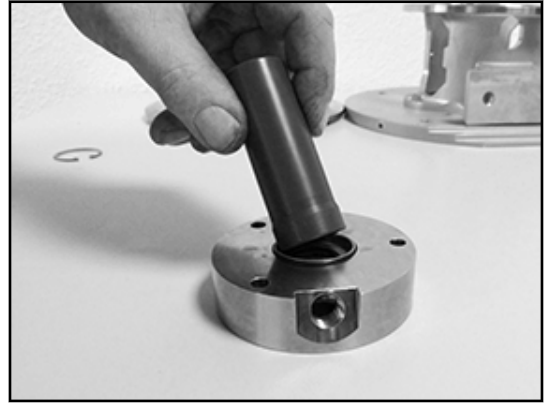

5. Insert the circlip 0932.09 into the seal cartridge (0491.00).

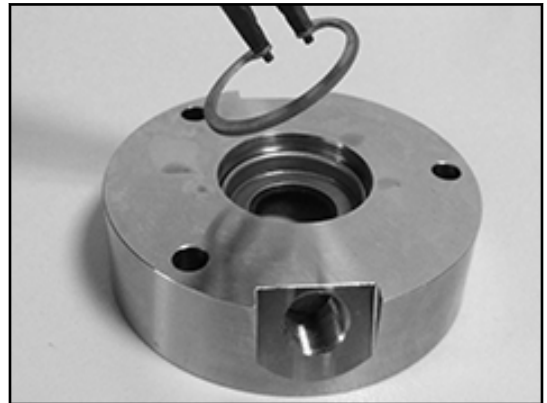

6. Wet hex socket screws (0914.05) with Loctite 243 and connect the intermediate motor stool (0346.00) with the motor stool (0340.00). Note the torques on page 26.

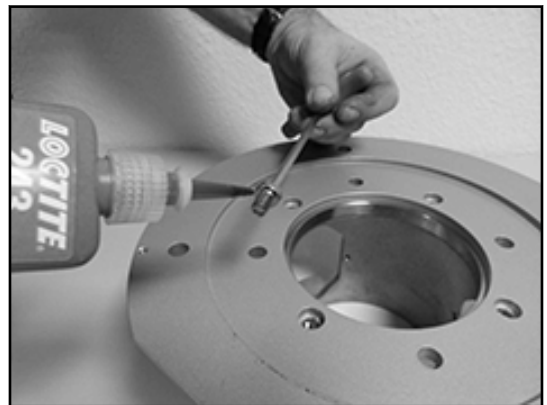

7. Moisten the O-ring (0412.02) and insert it into the seal cartridge (0491.00).



8. Grease hex head screws (0901.32) with Klüber paste and connect the seal cartridge (0491.00) with the back plate (0161.00). Note the torques on page 26.



9. Wet set screws (0902.02) with Loctite 243 and screw them into the back plate (0161.00) up to the stop.

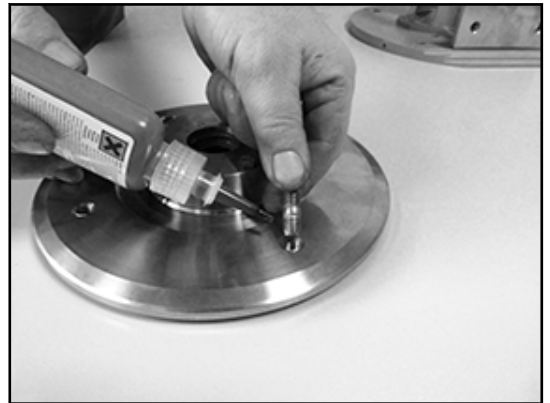

10. Connect the back plate (0160.00) with the motor stool (0340.00), using the spring washers (0554.73) and the hexagon nuts (0920.04). Note the torques on page 26.



11. Wet a thread of the pipes (0736.04) and (0736.05) with Loctite 2701 (high-strength) and connect it with the elbows (0731.30) and (0731.31).



12. Wet the other threads of the pipes (0736.04) and (0736.05) with Loctite 243 (medium strength) and connect it with the seal cartridge (0491.00).

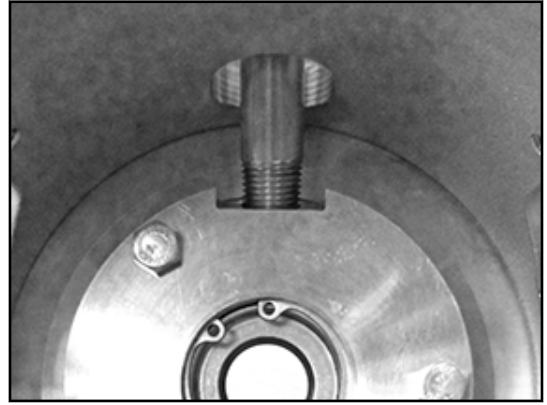

13. Grease the centring for holding the motor stool at the motor flange and grease the screw connection with Klüber paste.
14. Push the motor stool (0340.00) onto the shaft (0211.00) and fasten it with the hex head bolts (0901.50), washers (0554.74) and (0554.75) and hexagon nuts (0920.09) to the motor flange. Note the torques on page 26.

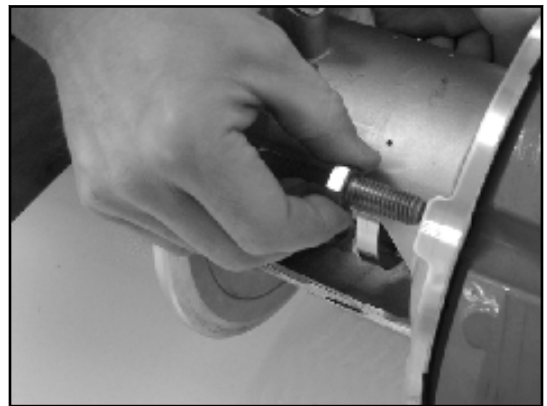

15. Push the mounting sleeve onto the shaft (0211.00) and position the clamp connection.



16. Screw on the impeller nut (0922.00) without the O-ring seal and tighten. This sets the correct length of the shaft.

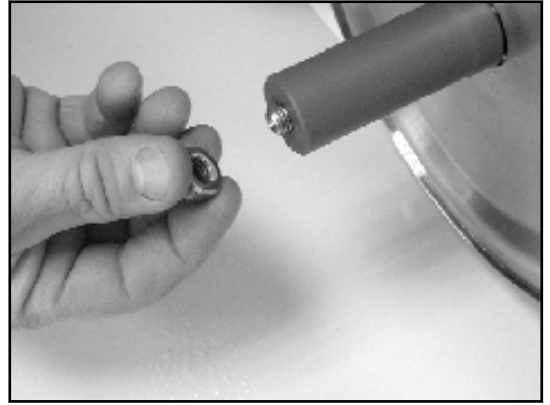

17. Tighten the hex head screws (0901.49) of the clamp connection in a crosswise sequence. Note the torques on page 26.

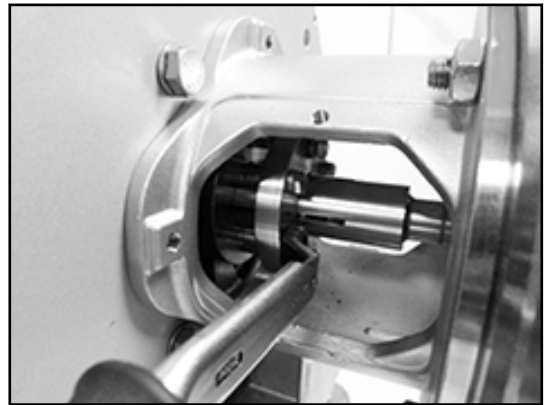

18. Check the rotation of the pump shaft (0211.00). Maximum permissible deviation: 0.05 mm (0.2 thou). In case of larger runout, dismount clamp connection and reinstall.



19. With replacement motor stool: clean the surface of the motor stool (0340.00) and attach the nameplate (0970.00).

⇒ Motor, motor stool and pump shaft have been installed.
 Further assembly: *8.3.5 Installing single mechanical seal* or *8.3.6 Installing the single encapsulated mechanical seal*.

8.3.4 Determining the gap size

Gap size

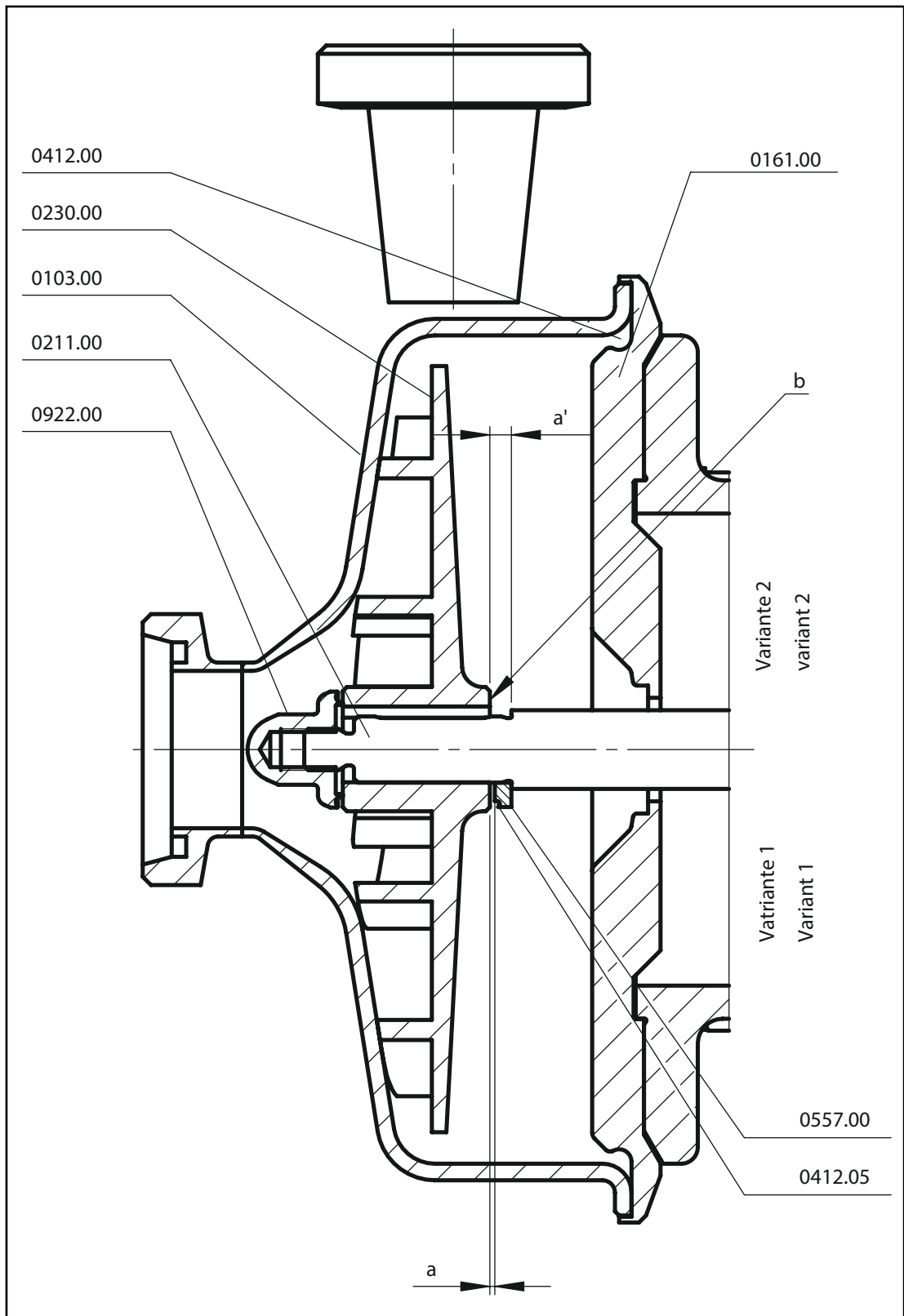

Figure 8-9 - Cutaway view HYGIA with HPM casing

The gap size needs to be determined only if modifying/replacing the impeller or the ring housing. The gap between the impeller and the annular casing contributes crucially to complying with the intended use. In the case of pumps with a free-flow impeller, it

is not necessary to determine the gap size. Such pumps have a larger gap by design, which does not have to be adjusted exactly.

Determining the gap size - pump with conical spring mechanical seal

Responsibility

- Trained customer specialist

INFO Determination of the air gap (a or a') for pumps with conical spring mechanical seal and seal spacer.

Prerequisites

- The key (0940.00) has been removed.
- The mechanical seal (0433.00) and the O-rings (0412.00) and (0412.05) have been removed.

Tools

- Feeler gauge

1. Push the seal spacer (0557.00) onto the shaft (0211.00) as far as it will go.
2. Push the impeller (0230.00) onto the shaft (0211.00), making sure it does not contact the seal spacer (0557.00). It should be flush with the shaft thread at the front.
3. Carefully place the annular casing (0103.00) against the back plate (0161.00). Thus, the impeller (0230.00) is pushed by the annular casing (0103.00) into the zero gap position. The air gap then forms behind the impeller.
4. Remove annular casing (0103.00) so that the impeller (0230.00) does not move, retaining its position.
5. Screw the impeller nut (0922.00) onto the shaft so that it just touches the impeller without moving it.
6. Determine gap a between the seal spacer (0557.00) and the impeller (0230.00) using a feeler gauge.

⇒ The gap size has been determined.

INFO Permissible gap size: 0.7 mm – 1 mm (27.6 – 39.4 thou). The sealing washers 0557.00 are available in various thickness dimensions - 0.25 mm (9.84 thou). If the permissible gap size cannot be achieved with the seal spacer used, this must be replaced by another one.

Determining the gap - pump with conical spring mechanical seal

Responsibility

- Trained customer specialist

INFO

Determination of the air gap (a or a') for pumps with encapsulated mechanical seal.

Prerequisites

- The key (0940.00) has been removed.
- The mechanical seal (0433.00) and the O-rings (0412.00) and (0412.05) have been removed.

Tools

- Feeler gauge

1. Push the impeller (0230.00) onto the shaft (0211.00), making sure it does not contact the shaft shoulder. It should be flush with the shaft thread at the front.
2. Carefully place the annular casing (0103.00) against the back plate (0161.00). Thus, the impeller (0230.00) is pushed by the annular casing (0103.00) into the zero gap position. The air gap then forms behind the impeller.
3. Remove annular casing (0103.00) so that the impeller (0230.00) does not move, retaining its position.
4. Screw the impeller nut (0922.00) onto the shaft so that it just touches the impeller without moving it.
5. Determine gap a between the seal spacer (0557.00) and the impeller (0230.00) using a feeler gauge.

⇒ The gap size has been determined.

INFO

Permissible gap size: 4.7 mm- 5.5 mm (0.185" - 0.217"). The actual gap size is obtained by subtracting the 4 mm (0.157") shim integrated in the encapsulated mechanical seal. If the measured distance a' is less than 4.7 mm (0.185"), the back of the impeller hub (b) unscrewed by this difference.

8.3.5 Installing single mechanical seal

Installing single conical spring mechanical seal

Responsibility

- Trained customer specialist

Prerequisites

- The pump has been disassembled.

Tools

- Equipment and tools from the GEA Hilge assembly tool kit
- Spray bottle
- Plastic mounting sleeve
- Mounting sleeve

INFO HILGE assembly tools prevent damage to the mechanical seal during assembly.

1. Wet the stationary ring (counter ring) of the mechanical seal (0433.00) and the shaft (0211.00) with clean water.



2. Push the counter ring of the mechanical seal (0433.00) into the seat of the back plate (0161.00).



3. Push the mounting sleeve onto the shaft shoulder.

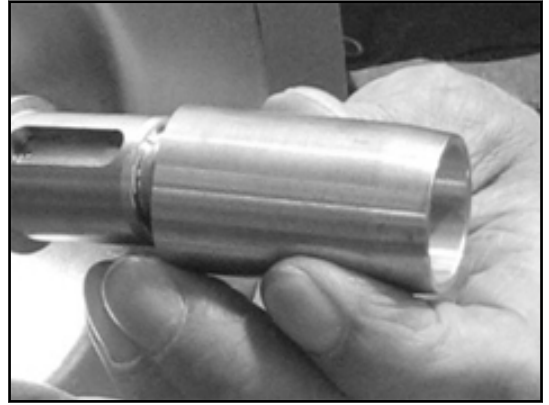

4. Moisten the mounting sleeve with clean water.
5. Push the rotating unit of the mechanical seal (0433.00) in the assembled state onto the shaft (0211.00) as far as it will go.



6. Push the seal spacer (0557.00) onto the shaft.



⇒ The single conical spring mechanical seal has been installed.
Further assembly with *8.3.7 Install impeller*

8.3.6 Installing the single encapsulated mechanical seal

Installing the single mechanical seal - spring encapsulated (hygiene)

Responsibility

- Trained customer specialist

Prerequisites

- The pump has been disassembled.

Tools

- Equipment and tools from the GEA Hilge assembly tool kit
- Spray bottle
- Plastic mounting sleeve

INFO HILGE assembly tools prevent damage to the mechanical seal during assembly.

1. **ATTENTION** Danger due to contamination
Contamination can endanger food safety.
 - Carefully inspect the seat of the mechanical seal.
 - Pay attention to groove and pin for mechanical seal with anti-twist protection.

Check the shaft and stationary ring holder for impurities and damage (sharp edges). If necessary, clean or replace parts.

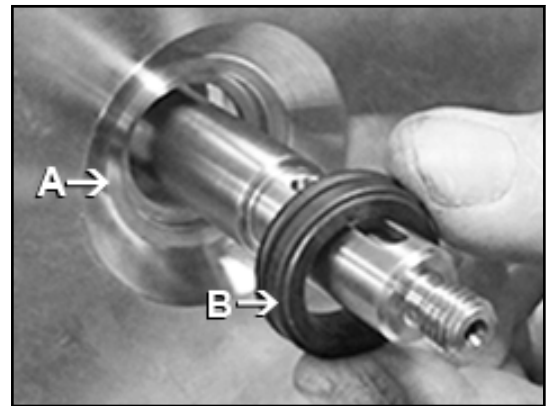

Position Description

A	Stationary ring holder
B	Fixed ring of the mechanical seal (stationary ring)

2. Check all O-rings of the mechanical seal for correct seating, and adjust if necessary.
 3. Moisten all sliding O-rings with water.
 4. Slide the stationary ring (counter ring) of the mechanical seal (0433.00) along with the O-ring over the shaft into the seat. On a version with anti-twist protection, the slot and pin positions must match.
 5. Push the rotating part of the mechanical seal (0433.00) in the assembled state onto the shaft as far as it will go using a slight rotating motion.
- ⇒ The single encapsulated mechanical seal has been installed.
Further assembly with *8.3.7 Install impeller*

8.3.7 Install impeller

Install impeller

Responsibility

- Trained customer specialist

Prerequisites

- The mechanical seal has been installed.

Tools

- Equipment and tools from the GEA Hilge assembly tool kit
- Klüber paste UH1 96-402
- Extractor
- Spray bottle
- Socket wrench
- Socket wrench bit

INFO HILGE assembly tools prevent damage to the mechanical seal during assembly.

1. Insert the key (0940.00).



2. Insert the O-ring (0412.05) into the seal spacer (0557.00) or mechanical seal (0433.00).



3. Grease impeller seat and shaft thread with Klüber paste.



4. Install impeller (0230.00).



5. Grease the thread of the impeller nut (0922.00) with Klüber paste.
6. **INFO**
Only use original lock washers from GEA Hilge to fasten the impeller and replace them after they have been reused five times.

Grease lock washer (0930.00) with Klüber paste.

7. Grease lock washers as shown.

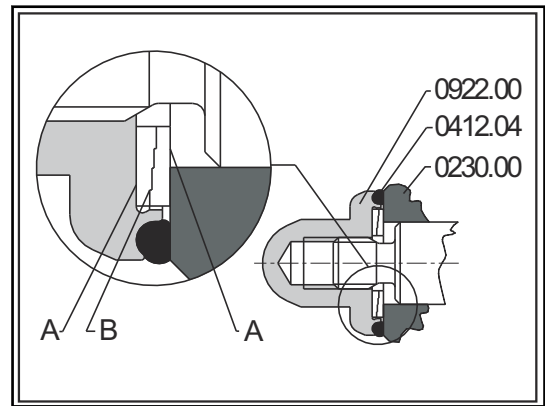

Position Description

(0230.00) impeller | (0412.04) O-ring

(0922.00) Impeller nut

(A) Fine gearing - greased

(B) Coarse gearing against each other - greased

8. Insert the lock washers (0930.00) into the impeller nut (0922.00).

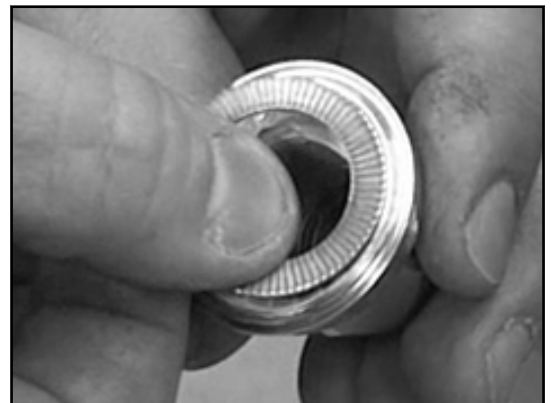

9. Unscrew impeller nut (0922.00) by hand. Leave a gap of about 3 mm for the O-ring (0412.04).



10. Wet the O-ring (0412.04) with water and use the impeller nut (0922.00) to push it into the gap between the impeller nut (0922.00) and the impeller (0230.00).

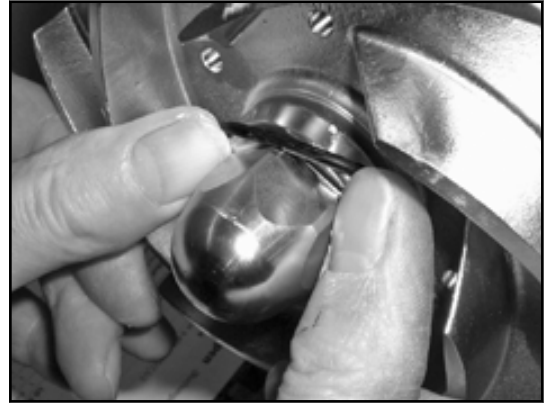

11. **ATTENTION** Danger through surface damage
Damaged and scratched surfaces can cause contamination and endanger food safety.

- Always tighten impeller nut with socket wrench and insert.

Stop the impeller (0230.00) with the centring key and tighten the impeller nut (0922.00). Note the torques on page 26.

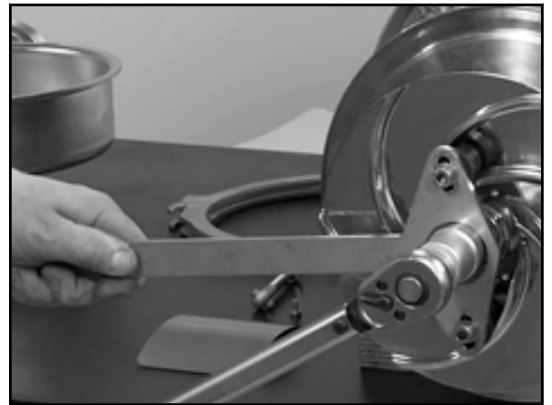

12. With open conical spring: relax the spring of the mechanical seal (0433.00) against the seal spacer (0557.00) using the extractor.

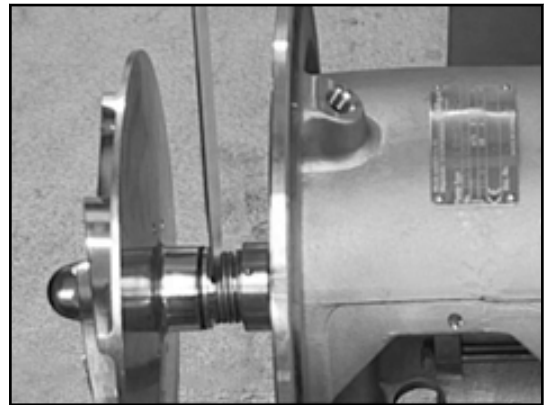

- ⇒ The impeller has been installed.
Further assembly with *Installing KLM pump casing* or *Installing HPM pump casing*.

8.3.8 Installing pump casing

Installing KLM pump casing

Responsibility

- Trained customer specialist

Prerequisites

- The impeller has been installed.

Tools

- Equipment and tools from the GEA Hilge assembly tool kit
- Klüber paste UH1 96-402
- Plastic hammer
- Spray bottle
- Machine spirit level
- Spanner

INFO HILGE assembly tools prevent damage to the mechanical seal during assembly.

1. Wet the O-ring (0412.00) with water and insert it into the back plate (0161.00).

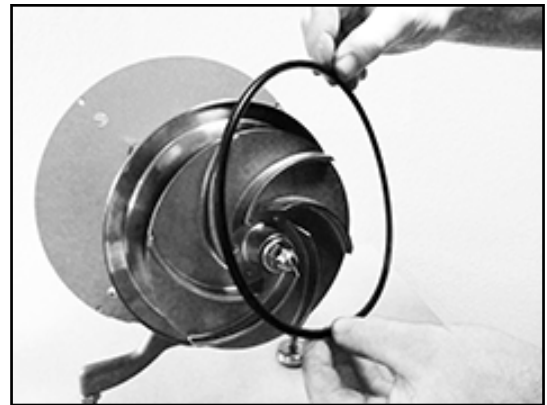

2. Install the annular casing (0103.00).



3. Grease the thread of the connecting screw (0905.00) with Klüber paste.

- Note the direction specification on the clamp ring and install the upper and lower clamp ring (0501.00 / 0501.01). Tighten the tie bolt (0905.00), the washer (0554.00) and the hexagon nut (0920.00) only handtight.



- Align the annular casing (0103.00) via the pressure piece using a mechanic's spirit level.

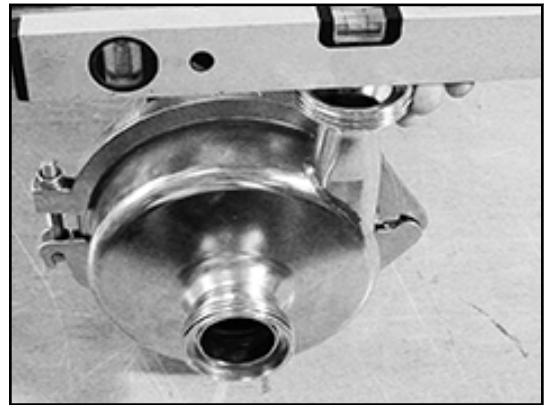

- Use a plastic hammer to bring the clamp ring to the correct position and tighten the hexagon nut (0920.00). Note the torques on page 26.
- ⇒ The KLM pump casing has been installed.

Installing HPM pump casing

Responsibility

- Trained customer specialist

Prerequisites

- The impeller has been installed.

Tools

- Equipment and tools from the GEA Hilge assembly tool kit
- Spray bottle
- Spanner

INFO HILGE assembly tools prevent damage to the mechanical seal during assembly.

1. Wet the O-ring (0412.00) with water and insert it into the back plate (0161.00).
2. Install the annular casing (0103.00).
3. Fasten the casing (0103.00) using the hex head screws (0901.07), spring washers (0934.03), and cap nuts (0927.00). Note the torques on page 26.



⇒ The HPM pump casing has been installed.

9 Faults

This chapter contains information about handling faults at the pump. In addition, it describes the personnel qualifications required for the individual actions.

It addresses all those who carry out actions at the pump in this context.

INFO For all troubleshooting, observe chapter 2 *Safety* in this operating manual.

9.1 Faults and remedies

Faults and remedies

Malfunction	Possible cause	Measure
Pump does not deliver or pump delivers with inadequate power.	Incorrect electrical connection (2 phases).	Check electrical connection, and correct if necessary.
	Incorrect direction of rotation.	Change phases of power supply (swap motor poles).
	Air in suction line or pump.	Vent and prime suction pipe or pump.
	Back pressure too high.	Reset operating point according to the data sheet. Check system for contamination.
	Suction head too high, NPSH system (supply) too low.	Raise suction side liquid level, fully open the check valve in the suction line.
	Lines clogged or foreign objects in the impeller.	Open pump and eliminate malfunctions.
	Air inclusion due to defective seal.	Check and, if necessary, replace pipe seals, pump casing seals and shaft seals.
Motor protection switch turns off, motor is overloaded.	Pump is blocked due to clogging.	Open pump and eliminate malfunctions.
	Pump is blocked by contacting due to strain on the pump body via the piping. (Check for damage.)	Install pump without strain, support piping by fixed points.
	Pump runs beyond its rated operating point.	Adjust operating point according to data sheet.
	The fluid density or viscosity of the liquid is higher than stated in the order.	If a lower power than specified is sufficient, reduce the flow rate on the outlet side. Otherwise provide a more powerful motor.

Malfunction	Possible cause	Measure
	Motor protection switch is not set properly	Check the setting, replace the motor protection switch if necessary.
	Motor runs on 2 phases.	Check electrical connection, replace defective fuse.
Pump causes too much noise. Pump runs unevenly and vibrates.	Suction head too high, NPSH system (supply) too low.	Raise suction side liquid level, fully open the check valve in the suction line.
	Air in suction line or pump.	Vent and prime suction pipe or pump.
	Back pressure is less than indicated.	Adjust operating point according to data sheet.
	Impeller is unbalanced.	Clean, check and balance the impeller.
	Worn internal parts.	Replace parts.
	Pump is strained (start-up noise - check for damage.)	Install pump without strain, support piping by fixed points.
	Bearings are damaged.	Replace bearings.
	Bearings have too little, too much or inappropriate lubricant.	Add, reduce or replace lubricants.
	Motor fan defective.	Replace the fan motor.
	Foreign objects in the pump.	Open and clean the pump. With self-priming pumps connect a screen ahead if necessary.
Leakage at the pump body, connections, mechanical seal, gland or socket seal.	Pump is strained, causing leaks at the pump body or at the connections.	Install pump without strain, support piping by fixed points.
	Housing seals and connection seals defective.	Replace casing seals and/or connection seals.
	Mechanical seal soiled or sticky.	Check and clean mechanical seal.
	Mechanical seal worn.	Replace the mechanical seal.
	Surface of shaft or shaft sleeve shrunk.	Replace shaft or shaft sleeve, re-pack gland seal.
	Elastomer unsuitable for the pumped fluid.	Use suitable elastomer for pumped fluid and temperatures.

Malfunction	Possible cause	Measure
Impermissible temperature increases at pump, bearing housing or motor.	Air in suction line or pump. Suction head too high, NPSH system (supply) too low.	Vent and prime suction pipe or pump. Raise suction side liquid level, fully open the check valve in the suction line.
	Bearings have too little, too much or inappropriate lubricant.	Add, reduce or replace lubricants.
	Pump with bearing housing is strained.	Install pump without strain, support piping by fixed points. Check coupling alignment.
	Axial thrust is too high.	Check the relief holes in the impeller and the split rings at the inlet.
	Motor protection switch is defective or not set properly.	Check the setting, replace the motor protection switch if necessary.
	Pressure valve closed.	Open pressure valve.

10 Decommissioning, dismantling and disposal

This chapter contains information about decommissioning the pump and describes dismantling and disposal. The target group for this chapter are all those who carry out actions at the machine in this context.

This chapter contains information about decommissioning and disposing of the pump. The target group for this chapter are all those who carry out actions at the pump in this context.

INFO For all decommissioning, observe chapter 2 *Safety* in this document.

10.1 Decommissioning

Longer-term decommissioning

Responsibility

- Customer specialist

Prerequisites

- Shutting down the pump is completed. See chapter 6.6 *Shutdown*
- Pump is secured against being switched back on again.

1. Drain the pump with the system.
2. Clean the pump, see chapter 7 *Cleaning*, page 53
3. Switch the cleaning flow off and drain the cleaning system.
4. Heed storage conditions, see chapter 4.1 *Storage*, page 31

⇒ Longer-term decommissioning has been completed.

10.2 Dismantling

Responsibility

- Customer specialist

Prerequisites

- Make sure that no process is in operation in the area concerned during disassembly.

1. Drain the pump and all the pipeline elements leading to the pump.
2. Drain the cleaning lines and cleaning containers.
3. Disconnect the power supply.
4. Take the pump out of the pipe section, with all housings and housing connections if possible.
 - Pump is dismantled.

10.3 Disposal

Dispose of the pump in an environmentally friendly way. Observe the statutory waste disposal regulations applicable at the place of installation.

The pump consists of the following materials:

- Metals
- Synthetic materials
- Electronic parts
- Lubricants containing oil and grease

Separate the different materials and dispose of them correctly sorted. Also observe the instructions regarding disposal in the operating manuals for the individual components.

11 Annex

11.1 Clearance certificate

Clearance certificate

Certificate	Your specifications	
We, the undersigned, together with this clearance certificate hereby order the following pump and its accessories to be inspected/repaired:	Pump specifications Type: Pump number: Delivery date:	Reason for inspection/repair order:
The pump (please mark with a cross)	___ has not been used in harmful media. ___ came into contact with substances requiring special labeling or pollutant substances.	If known, please specify the last pumped medium:
The pump was drained carefully before shipping / provision and cleaned on the outside and inside (please mark with a cross).	___ Special precautions are not necessary during further handling.	___ The following safety precautions are necessary concerning flushing liquid, residual liquids and disposal:
We assure that the above information is correct and complete and that the shipment is carried out in accordance with the legal requirements.	Company: Street, number: Postcode, town Country Phone: Fax: E-mail:	Name (printed) Date Company stamp / signature

GEA Hilge
Niederlassung der GEA Tuchenhagen GmbH
Hilgestraße 37 – 47
55294 Bodenheim, Germany

Tel +49 6135 7016-0

© GEA Hilge. All rights reserved. Subject to modifications. Printed in Germany.