

GEA Hilge

MAXA ADAPTA

Installation and operating instructions

English Translation of the original operating
manual 98687126-0317 GB

**Dichiarazione di conformità CE per le macchine
ai sensi della Direttiva Macchine CE 2006/42/CE, Allegato II 1. A**

Produttore: **GEA HILGE**
Niederlassung der GEA Tuchenhausen GmbH
Hilgestraße 37-47
D 55294 Bodenheim

In qualità di produttore, dichiariamo sotto la nostra esclusiva responsabilità che la macchina

Descrizione: Pompa centrifuga
Modello / Tipo: GEA Hilge MAXA ADAPTA, ADAPTA-SUPER
GEA Hilge MAXA BLOC
GEA Hilge MAXA L, L-SUPER
GEA Hilge MAXA CN, CN-SUPER
GEA Hilge MAXA C

è conforme a tutte le disposizioni pertinenti della suddetta e delle seguenti direttive:

Direttive CE pertinenti: 2006/42/CE Direttiva Macchine CE

Norme armonizzate EN 809:1998/A1+AC(D)
applicate, nello specifico:

EN ISO 12100:2010

Note: Dichiariamo inoltre che la documentazione tecnica specifica per la suddetta macchina è stata redatta in conformità all'Allegato VII, parte A, e che, su richiesta motivata, siamo tenuti a trasmetterla alle autorità nazionali competenti tramite supporto dati.

Persone autorizzate alla redazione e al rilascio della documentazione tecnica: **GEA HILGE**
Niederlassung der GEA Tuchenhausen GmbH
Hilgestraße 37-47
55294 Bodenheim, Germania

Bodenheim, 05.12.2022



Karsten Becker
Amministratore delegato

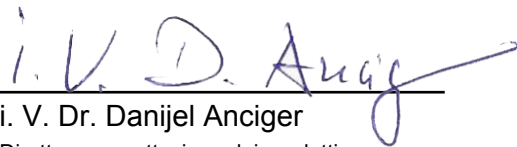

i. V. Dr. Danijel Anciger
Direttore progettazione dei prodotti

UKCA - Declaration of Conformity

We herewith declare,

GEA HILGE
Niederlassung der GEA Tuchenhagen GmbH
Hilgestraße 37-47
D 55294 Bodenheim

that the machinery

Denomination: Centrifugal pump
Model / Type: GEA Hilge MAXA ADAPTA, ADAPTA-SUPER
GEA Hilge MAXA BLOC
GEA Hilge MAXA L, L-SUPER
GEA Hilge MAXA CN, CN-SUPER
GEA Hilge MAXA

is in conformity with the following UK-directives, provided that the site conditions for the commissioning are met as specified in the engineering documents, in particular in the operation manual:

Supply of Machinery (Safety) Regulations 2008, 2008 No. 1597

Designated standards used: EN 809:1998+A1:2009+AC(D)
EN ISO 12100:2010

Authorized person for compiling and handing over technical documentation: **GEA Mechanical Equipment UK Ltd**
Westfalia House
Old Wolverton Road, Old Wolverton, Milton Keynes
MK12 5PY, United Kingdom

Bodenheim, 05.12.2022



Karsten Becker
Managing Director



i. V. Dr. Danijel Anciger
Manager Product Development

Original installation and operating instructions.

CONTENTS

1. Introduction	5
1.1 Target group	5
1.2 Symbols and formatting	5
1.3 References to the document	5
2. Safety	6
2.1 Operator notes	6
2.1.1 Unpacking the pump	6
2.1.2 Storing the pump	6
2.2 Safety instructions in the operating manual	6
2.3 Identification of instructions in the operating manual	6
2.3.1 Structure of safety instructions	6
2.4 Qualification and training of personnel	6
2.5 Dangers caused by failure to follow the safety instructions	6
2.6 Safety-conscious work	6
2.7 Safety instructions for the operator/user	7
2.8 Unauthorised modifications and spare parts	7
2.9 Improper operation	7
2.10 Transport	7
2.11 Cleaning	8
2.11.1 CIP	8
2.11.2 SIP	8
2.12 Repair contract	9
3. Product description	9
3.1 Pump overview	9
3.2 Description	9
3.2.1 Areas of application	9
3.3 Proper usage	9
3.3.1 Pumped liquids	9
3.3.2 Minimum flow rate, Qmin	9
3.3.3 Connections and pipelines	9
3.3.4 Motor operation	9
3.3.5 Design	9
3.4 Technical data	10
3.4.1 Type key	10
3.4.2 Pump serial number	10
3.4.3 Nameplate	10
3.4.4 Performance data	10
3.4.5 Noise emissions	10
3.4.6 Weights	11
3.4.7 Maximum operating temperatures	12
3.4.8 Maximum operating pressure	12
4. Mounting, installation and connection	12
4.1 Inspection before pump installation	12
4.1.1 How to check free running of the impeller	12
4.2 Set-up and alignment of the pump	12
4.3 Installation in the pipeline	12
4.3.1 Operation of the mechanical seal	13
4.3.2 Space requirements	13
4.3.3 Reduction of noise and vibration	14
4.4 Connection of flushing system	14
4.4.1 Double mechanical seal	14
4.4.2 Double mechanical seal - tandem arrangement	14
4.4.3 Double mechanical seal, back-to-back arrangement	14
4.5 Electrical connections	15
4.5.1 Star connection	15
4.5.2 Delta connection	15
4.5.3 Frequency converter operation	15
4.5.4 Checking the direction of rotation after connection	15
5. Start-up / shut-down	16
5.1 Start-up	16
5.1.1 Check application conditions	16
5.1.2 Starting up the pump	16
5.1.3 Functional check of the mechanical seal	16
5.2 Shutting down the pump	16
5.2.1 Cleaning the pump after shut-down	16

6. Maintenance/servicing	16
6.1 Safety instructions for installation, inspection and maintenance work	16
6.2 Maintenance of the pump	17
6.3 Maintenance of the motor	17
6.3.1 Motors without lubrication fittings	17
6.3.2 Motors with lubrication fittings	17
6.4 Maintenance of the Adapta® bearing housing	18
6.4.1 Bearing housing	18
6.4.2 Design of bearing housing, sizes 1 and 2	18
6.4.3 Design of bearing housing, size 3	18
6.5 Assembly	19
6.5.1 Parts overview, MAXA pump sizes 65-160/200	19
6.5.2 Parts overview, MAXA pump sizes 80, 100, 65-250	20
6.5.3 Bearing housing, sizes 1 and 2	21
6.5.4 Bearing housing, size 3	22
6.5.5 Coupling and motor	23
6.5.6 Instructions for disassembly	23
6.5.7 Instructions for assembly	23
6.5.8 Assembly of the bearing housing, sizes 1 and 2	24
6.5.9 Assembly the bearing housing, size 3	27
6.5.10 Mechanical shaft seals for MAXA 80, 100, 65-250	30
6.5.11 Mechanical shaft seals for MAXA 125-, 150-	30
6.5.12 Single mechanical shaft seal, seat in cartridge seal	31
6.5.13 Single mechanical seal, seat in backplate liner	31
6.5.14 Double mechanical shaft seal, tandem	32
6.5.15 Double mechanical shaft seal, back to back	33
6.5.16 Single mechanical shaft seal, seat in cartridge seal	34
6.5.17 Double mechanical shaft seal, tandem	35
6.5.18 Double mechanical shaft seal, back to back	36
6.5.19 Assembly of the impeller and volute casing	37
6.6 Troubleshooting	38
6.7 Disposal	39
6.8 HILGE assembly tool kit	40
6.8.1 Content and use	40
7. Certificate of non-objection	41

1. Introduction

Overview

This section describes the requirements that are important for reading and understanding this operating manual. The symbols and formats that make the reading easier are also described.

1.1 Target group

This operating manual is intended for:

- the operators of the pump
- maintenance and repair personnel.

It is assumed that all such personnel will have the basic technical background required for the start-up, maintenance, and repair of pump systems.

Sections intended only for specially authorised personnel are indicated by a preceding notation to this effect.

1.2 Symbols and formatting

The following symbols and formats are intended to make it easier to read this document:

- enumerations and listed items.

Instructions

Instructions that must be carried out in a specific sequence are numbered in the corresponding order.

Safety instructions

The system used to identify safety instructions is described in section 2.3 on page 6.

1.3 References to the document

Copyright

This document may not be copied, translated into other languages, or made available to third parties without our explicit written consent.

Technical changes

Design variants, technical data, and spare part numbers are subject to technical changes.

We reserve the right to make changes for the sake of further technical development.

2. Safety

Overview

This section describes what you have to consider for your own safety. Read this important section attentively and follow the instructions!

2.1 Operator notes

2.1.1 Unpacking the pump

In order to avoid transport damage, all of our pumps are professionally packed when they leave our warehouse.

If, after carefully unpacking and closely reviewing the shipment, you nevertheless detect damage, please immediately inform the transporter (railway, post office, freight forwarder, shipping company). Please file your damage claim with them. The transport risk is assumed by the customer as soon as the shipment leaves our warehouse.

2.1.2 Storing the pump

If you do not use the pump straight away, correct storage conditions are just as important as careful installation and appropriate maintenance in order to ensure smooth subsequent operation. The pump should be protected against cold, moisture and dust, and should also be shielded against mechanical impacts.

Trained personnel are required for proper installation and maintenance.

2.2 Safety instructions in the operating manual

Read all safety instructions!

The operating manual contains all the basic information required for the set-up, operation, and maintenance of the pump. The installer as well as the technical personnel or operator responsible for the pump must therefore read this operating manual before installing and starting the pump. The operating manual must always be available at the site where the pump/system is used.

The general safety instructions presented in this section as well as the specific safety instructions in later sections must be followed.

2.3 Identification of instructions in the operating manual

Symbols

The safety instructions presented in this operating manual are identified as shown below.



A



B

CAUTION

C

K.0319V1 | K.0320V1

Fig. 1 Symbols for safety instructions

- A: Failure to follow these safety instructions can endanger personnel.
- B: Safety instructions warning against electric voltage.
- C: Failure to follow these safety instructions can endanger the pump and its operation.

Signal words

The following signal words are used to classify the safety instructions:

DANGER

Characterises an imminent hazard with a high risk which can cause death or serious bodily injury.

WARNING

Characterises a possible hazard with a medium risk which can cause death or bodily injury if it is not avoided.

CAUTION

Characterises a hazard with a minor risk which can cause minor or medium-level bodily injury if it is not avoided.



Do not remove instructions from pump

Instructions attached directly to the pump, such as a direction-of-rotation arrow, must be noted and kept in completely legible condition.

Damaged or illegible instructions must be replaced.

2.3.1 Structure of safety instructions

The safety instructions are structured as follows and use the symbols and signal words shown here:

SIGNAL WORD	
	Description of danger! <ul style="list-style-type: none">▲ Possible consequence.▶ Action to eliminate the danger.
Example:	
	DANGER Electric shock if electrical parts are touched! <ul style="list-style-type: none">▲ Death, serious bodily injury, damage to property.▶ Before attempting to diagnose any fault, make sure that the main switch has been switched off. It must be ensured that the power supply cannot be accidentally switched on.

2.4 Qualification and training of personnel

The employees operating, maintaining, inspecting, and installing the pump must have the appropriate qualifications for this work. The operator must define in detail the tasks for which the employees are responsible, the tasks of which they are in charge, and the manner in which they are supervised.

If the employees do not have the necessary knowledge, they must be instructed and trained accordingly. This can be done, if necessary, by the manufacturer/supplier under contract to the operator. The operator must also ensure that the employees fully understand the contents of the operating manual.

2.5 Dangers caused by failure to follow the safety instructions

If these safety instructions are not followed, employees, the pump and the environment will be in danger.

Failure to follow the safety instructions can lead to the loss of the right to file claims for damages.

Failure to follow instructions can, for example, lead to the following hazards:

- breakdown of important functions of the pump/system
- failure of recommended methods of maintenance and repair
- endangerment of personnel by electrical, mechanical, and chemical hazards
- endangerment of the environment by leakage of hazardous materials.

2.6 Safety-conscious work

The safety instructions given in this operating manual, the existing national regulations for accident prevention, and any applicable internal working, operating, and safety instructions of the operator must be followed.

2.7 Safety instructions for the operator/user



WARNING

Hot or cold mechanical components!

- ▲ Serious bodily injury.
- ▶ Take structural measures to prevent contact with them!



WARNING

Trapping hazard!

- ▲ Death, serious bodily injury, damage to property.
- ▶ Do not remove protection against contact with moving parts (e.g. coupling guard) while the pump is in operation.
- ▶ Replace defective safety equipment immediately.



WARNING

Contact with hazardous substances (e.g. inhalation)!

- ▲ Death, serious bodily injury, damage to property.
- ▶ Drain away leakage of hazardous pumped liquids in such a way that there is no danger to personnel or to the environment.
- ▶ Follow legal regulations.
- ▶ If shaft seal fails, switch off the pump. Replace seal before next start-up.



WARNING

Tripping hazard from electric power cable!

- ▲ Death, serious bodily injury.
- ▶ Route the electric power cable in such a way that no one can trip over it (in case of portable pumps).



WARNING

Electrical hazard!

- ▲ Death, serious bodily injury.
- ▶ Use only approved electric cables and plugs.

2.10 Transport

WARNING

Falling loads!



- ▲ Death, serious bodily injury, damage to property.
- ▶ Transport work must only be performed by appropriately qualified persons, and all safety instructions must be observed.
- ▶ Use suitable load carrying equipment with sufficient capacity to transport the pump.
- ▶ Make certain there are no persons under the suspended load.
- ▶ Make certain the pump is aligned horizontally when it is lifted.

CAUTION

Incorrect lifting points!



- ▲ Damage to property.
- ▶ Fasten the rope to suitable lifting points.
- ▶ Never fasten a rope to the pump housing or suction/discharge port.
- ▶ If pump is equipped with shroud, remove shroud before transporting.

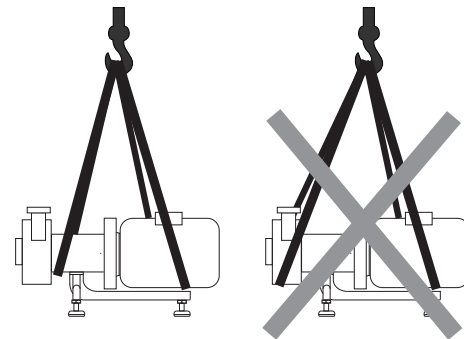

Fig. 2 Attachment points (example)

TN05 6441 4712

2.8 Unauthorised modifications and spare parts

No modifications or changes to the pump may be made without the written approval of the manufacturer. In the interest of safety, only original spare parts and accessories authorised by the manufacturer may be used. The use of other parts can exempt the manufacturer from liability for damage.

2.9 Improper operation

The operational reliability of the pump can be guaranteed only when it is used properly, as indicated in the relevant sections of the pump operating manual and the order papers.

The given limit values may not be exceeded under any circumstances.

2.11 Cleaning

To ensure the quality of sensitive liquids, pumps must be cleaned immediately after each use. Only this will remove adhesions and sedimentary deposition and avoid the contamination of products. To reach the best possible cleaning result, Hilge pumps are optimised with regard to gaps and dead spaces. They are designed in accordance with DIN EN 13951, and they are resistant to the detergents mentioned below. The cleaning happens inside the plant, without the need for disassembly or removal of parts.

Generally, distinction is made between CIP and SIP. The procedures must be based on state-of-the-art technology and guidelines of the EC. In every case the user must make sure that the cleaning and/or sterilisation processes used as well as the operating temperature and operating steps meet the targets set and are used for that purpose.

2.11.1 CIP

CIP means Cleaning In Place. The pump is completely flushed through with a detergent. The detergent used must be suitable for the cleaning task in question. The following table shows permitted detergents, their allowed concentration and specifications according to DIN 11 483 part 1.

Type of detergent	Chemical description	Max. concentration	Max. temperature* [°C]	Permitted pH value	Max. permitted CI content when mixed with water [mg/l]	Max. permitted contact time [h]
	NaOH	5 %	140 ⁽¹⁾	13-14	500	3
Alkalis	NaOH and NaClO	5 %	70	≥ 11		1
	NaClO or KCIO	300 mg/l active chlorine	20	≥ 9	300	2
			60			0.5
Acids	H ₂ SO ₄	1.0 / 1.5 % ⁽²⁾ 3.5 % ⁽³⁾	60		150 ⁽²⁾	1
					250 ⁽³⁾	
	H ₃ PO ₄ or HNO ₃	5 %	90		200 ⁽²⁾	1
					300 ⁽³⁾	
C ₂ H ₄ O ₃	0.0075 %	90			0.5	
				0.15 %		20
Iodophore	50 mg/l active iodine	30	≥ 3		300	2
						3

⁽¹⁾ Depends on the maximum permitted temperature of the pump

⁽²⁾ CrNi-steel (1.4301)

⁽³⁾ CrNiMo-steel (1.4401 / 1.4571)

Warning

Damage caused by detergent!



- ▲ Death, serious bodily injury, damage to property.
- ▶ Use only suitable detergent.
- ▶ Always note the safety instructions of the product information of the detergent.
- ▶ Always wear suitable safety equipment when working with detergent.
- ▶ Do not exceed the maximum permitted concentration of the detergent.
- ▶ Corrosive acids should be avoided, because they promote pitting corrosion.

Detergents containing hydrochloric acid (HCl) and/or hydrofluoric acid (HF) are not allowed. If you want to use special detergents and cleaning methods, please contact the supplier for information relating to the pump materials used. For a residue-free removal of

the detergent, the pump must be thoroughly flushed with water. The maximum permitted temperature can be found in section [Technical data](#)



Warning

Hot surfaces!

- ▲ Death, serious bodily injury, damage to property
- ▶ Do not touch the pump during cleaning. Pump surfaces can be very hot.

Disposal of detergent

Dispose of detergent in a professional and environmentally friendly way.

2.11.2 SIP

SIP means Sterilisation In Place. The pump will be sterilised by hot steam. For the hot-steam sterilisation or sanitisation, minimum temperatures of 121 °C must be in contact with all surfaces. The maximum permitted operating temperature can be found in section [Technical data](#).

The pump should never be operated during the SIP process. After the SIP process, a cool-down phase of minimum one hour is needed.



Warning

Hot surfaces!

- ▲ Death, serious bodily injury, damage to property.
- ▶ Do not touch the pump during the sterilisation and cool-down phases. Pump surfaces can have a temperature of more than 100 °C!



Warning

Dry running!

- ▲ Damage to property.
- ▶ Never operate the pump during the SIP process. The mechanical shaft seal will be destroyed.



Warning

Pressure surge!

- ▲ Death, serious bodily injury, damage to property.
- ▶ Before sterilisation, always evacuate the system completely of pumped liquid!

2.12 Repair contract

The duty to follow the legal regulations on work safety and the regulations on environmental protection means that all commercial enterprises must protect their employees, the public at large, and the environment from the harmful effects of hazardous materials.

Examples of legal regulations on work safety:

- the Workplace Act (ArbStättV)
- the Hazardous Materials Act (GefStoffV)
- the accident prevention regulations (BGV A1)
- regulations for environment protection e.g. the Recycling and Waste Law (KrW/AbfG), the Water Economy Law (WHG)
- all applicable laws, rules, guidelines, regulations etc. in the country of operation.

Certificate of non-objection

The certificate of non-objection attached to the shipment is a component of the inspection/repair contract. This does not affect our right to refuse acceptance of this contract for other reasons.

The certificate of non-objection can be found on page 41.

HILGE products and their parts will only be inspected and/or repaired if the certificate of non-objection is present and has been correctly completed by authorised and qualified technical personnel.

Pumps which have been operated in liquids exposed to radiation will not be accepted.

If any additional safety measures are required even after the careful draining and cleaning of the pump, the necessary information must be provided.

3. Product description

Overview

In this section you will get to know the pump as well as its design and application. The section "Technical Data" describes the limits of application. You must know and observe these limits.

3.1 Pump overview

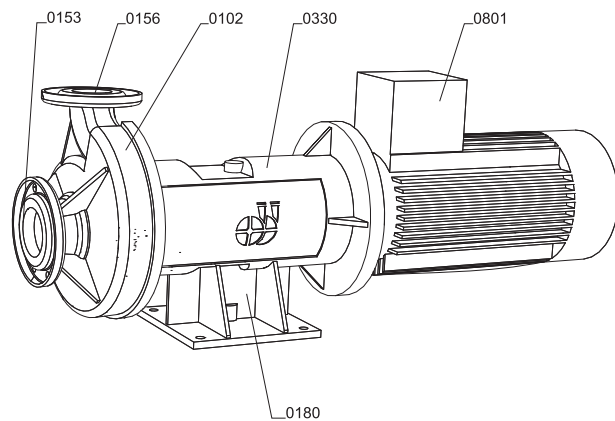

Fig. 3 MAXA Adapta®

- 0102 - pump housing
- 0153 - suction port
- 0156 - discharge port
- 0180 - Adapta® foot
- 0330 - bearing housing
- 0801 - flanged motor.

3.2 Description

The pump is a single-stage, end-suction, centrifugal pump designed in accordance with DIN EN 733 specifications. The hygiene requirements of modern process technology have been considered in the manufacture of the pump.

3.2.1 Areas of application

Standard design

Pumps of the standard design are used for:

- industrial applications
- textile technology
- surface treatment for environmental technologies
- all systems and processes employed in the production of foodstuffs, including dairy products and beverages.

3.3 Proper usage

WARNING



Improper usage!

- ▲ Death, serious bodily injury, damage to property.
- ▶ Pump only liquids that are specified in the order. The pump has been specially designed for that purpose.
- ▶ Operate the pump only in the electrical network specified in the order.

3.3.1 Pumped liquids

Only pure or slightly contaminated liquids may be pumped. These liquids may not chemically or physically attack the pump materials or reduce their strength. If liquids with a viscosity greater than that of water are to be pumped, make sure that the motor will not be overloaded. The pump may not be operated beyond the maximum permissible values. Even short periods of pressure overload (e.g. as a result of a pressure surge) should be avoided.

3.3.2 Minimum flow rate, Q_{min}

Do not operate pumps size 65 to 150 below the minimum flow rate of $Q_{min} = 10-15 \% Q_{opt}$.

3.3.3 Connections and pipelines

The nominal diameters of the system pipelines should be equal to or greater than the nominal diameters of the pump, i.e. DNE (suction side) and DNA (pressure side), and the elements that are to be connected to the pump must conform exactly to the design standard/specification of the mating connector piece installed on the pump. The suction line must be absolutely leakproof and if possible laid out in such a way that no air pockets can form. Avoid tight elbows and do not install valves immediately upstream of the pump. On the suction side, provide a straight pipe section with a minimum length of five times the pipe diameter. The suction head of the system may not exceed the suction head guaranteed by the pump.

3.3.4 Motor operation

Do not start and stop the motor more than 15 times per hour.

3.3.5 Design

All information and descriptions in this operating manual concerning the use and operation of the pumps are based exclusively on the standard designs.

These rules do not apply to special designs, customer-specific modifications, or random external influences that may occur during use and operation.

K.0245V1

3.4 Technical data

WARNING



Overloading the pump!

- ▲ Death, serious bodily injury, damage to property.
- ▶ Use the pump only under the indicated operating conditions.
- ▶ Also avoid brief overpressure situations (e.g. caused by pressure surges).

3.4.1 Type key

The HILGE pump designation is structured as shown below:

MAXA	100-200	ADY	125/200	30	2
Pump type					
Size					
Design					
Nominal diameter DN _S / DN _D					
Power [kW]					
Number of poles					

3.4.2 Pump serial number

The pump can be identified by the pump serial number. When ordering spare parts, always state the pump serial number.

3.4.3 Nameplate

The following information is given on the name plate:

- Pump-Type: Pump name
- Ser.-No.: Serial number
- Q: Flow rate
- H: Delivery head
- P: Motor rating
- n: Speed
- TAG No.:customer name
- YOM: Year of manufacture

3.4.4 Performance data

The performance data of the pump, head and flow rate are determined in accordance with ISO 9906:2012, grade 3B and documented on the acceptance records.

3.4.5 Noise emissions

Measured values according to DIN EN ISO 3746 for pump units. Uncertainty of measurement: 3 dB(A).

Motor power [kW]	L _{pfa} [dB(A)]	
	2-pole	4-pole
2.2	67	
3	73	63
4	73	63
5.5	73	63
7.5	75	72
11	75	72
15	76	76
18.5	76	76
22	75	75
30	77	75
37	77	76
45	78	76

Noise emissions caused by a pump are significantly affected by its application and construction. For this reason, no guarantee of accuracy is given for the values indicated here.

3.4.6 Weights

NOTE:

Please note that, depending on design and accessories, the weights may differ from those indicated. If presented with the pump/order number, the manufacturer can give you precise information.

- Cast iron foot
- Single, mechanical shaft seal
- SIEMENS motor.

MAXA Adapta[®], 2-pole

Pump size	Size of bearing housing	DNs	DNd	P2 [kW]	IEC size	Net weight [kg]
065-160	2	80[100]	65	5.5	132S	97
065-160	2	80[100]	65	7.5	132S	110
065-160	2	80[100]	65	11	160M	133
065-160	2	80[100]	65	15	160M	142
065-200	2	80[100]	65	11	160M	137
065-200	2	80[100]	65	15	160M	146
065-250	3	80[100]	65	15	160M	198
065-250	3	80[100]	65	18.5	160L	218
065-250	3	80[100]	65	22	180M	247
065-250	3	80[100]	65	30	200L	309
065-250	3	80[100]	65	37	200L	338
080-160	2	100[125,150]	80	11	160M	136
080-160	2	100[125,150]	80	15	160M	145
080-160	2	100[125,150]	80	18.5	160L	165
080-200	3	100[125,150]	80	15	160M	197
080-200	3	100[125,150]	80	18.5	160L	217
080-200	3	100[125,150]	80	22	180M	246
080-200	3	100[125,150]	80	30	200L	308
080-200	3	100[125,150]	80	37	200L	337
080-200	3	100[125,150]	80	45	225M	473
080-250	3	100[125,150]	80	30	200L	314
080-250	3	100[125,150]	80	37	200L	343
080-250	3	100[125,150]	80	45	225M	479
100-200	3	125[150]	100	18.5	160L	219
100-200	3	125[150]	100	22	180M	247
100-200	3	125[150]	100	30	200L	309
100-200	3	125[150]	100	37	200L	338
100-200	3	125[150]	100	45	225M	474
100-250	3	125[150]	100	30	200L	313
100-250	3	125[150]	100	37	200L	342
100-250	3	125[150]	100	45	225M	477

MAXA Adapta[®], 4-pole

Pump size	Size of bearing housing	DNs	DNd	P2 [kW]	IEC size	Net weight [kg]
065-160	2	80[100]	65	2.2	100L	77
065-160	2	80[100]	65	3	100L	82

Pump size	Size of bearing housing	DNs	DNd	P2 [kW]	IEC size	Net weight [kg]
065-160	2	80[100]	65	2.2	100L	80
065-160	2	80[100]	65	3	100L	85
065-160	2	80[100]	65	4	112M	92
065-160	2	80[100]	65	5.5	132S	103
080-160	2	100[125,150]	80	2.2	100L	79
080-160	2	100[125,150]	80	3	100L	84
080-160	2	100[125,150]	80	4	112M	91
080-200	3	100[125,150]	80	5.5	132S	158
080-200	3	100[125,150]	80	7.5	132M	173
080-250	3	100[125,150]	80	5.5	132S	165
080-250	3	100[125,150]	80	7.5	132M	180
080-250	3	100[125,150]	80	11	160M	203
080-315	3	100[125,150]	80	5.5	132S	181
080-315	3	100[125,150]	80	7.5	132M	196
080-315	3	100[125,150]	80	11	160M	219
080-315	3	100[125,150]	80	15	160L	245
080-315	3	100[125,150]	80	18.5	180M	264
080-315	3	100[125,150]	80	22	180L	284
100-200	3	125[150]	100	5.5	132S	159
100-200	3	125[150]	100	7.5	132M	174
100-250	3	125[150]	100	5.5	132S	163
100-250	3	125[150]	100	7.5	132M	178
100-250	3	125[150]	100	11	160M	201
100-250	3	125[150]	100	15	160L	227
100-315	3	125[150]	100	7.5	132M	196
100-315	3	125[150]	100	11	160M	219
100-315	3	125[150]	100	15	160L	245
100-315	3	125[150]	100	18.5	180M	264
100-315	3	125[150]	100	22	180L	284
100-315	3	125[150]	100	30	200L	345
125-250	3	150[200]	125	7.5	132M	221
125-250	3	150[200]	125	11	160M	244
125-250	3	150[200]	125	15	160L	270
125-250	3	150[200]	125	18.5	180M	289
125-250	3	150[200]	125	22	180L	309
125-315	3	150[200]	125	11	160M	273
125-315	3	150[200]	125	15	160L	299
125-315	3	150[200]	125	18.5	180M	318
125-315	3	150[200]	125	22	180L	338
125-315	3	150[200]	125	30	200L	399
125-315	3	150[200]	125	37	225S	509
150-250	3	200[250]	150	11	160M	273
150-250	3	200[250]	150	15	160L	299
150-250	3	200[250]	150	18.5	180M	318
150-250	3	200[250]	150	22	180L	338
150-250	3	200[250]	150	30	200L	399
150-315	3	200[250]	150	15	160L	318
150-315	3	200[250]	150	18.5	180M	337
150-315	3	200[250]	150	22	180L	357
150-315	3	200[250]	150	30	200L	418
150-315	3	200[250]	150	37	225S	528
150-315	3	200[250]	150	45	225M	568
150-400	3	200[250]	150	30	200L	450
150-400	3	200[250]	150	37	225S	561
150-400	3	200[250]	150	45	225M	601

3.4.7 Maximum operating temperatures

Exceeding the maximum permitted operating temperature!

Caution

- ▲ Death, serious bodily injury, damage to property.
- ▶ Never exceed the specified operating temperatures!

The following table lists the maximum permissible temperatures.

Design	Temp. [°C]
Standard design	95
Special design	150
Sterilisation (SIP)	140

3.4.8 Maximum operating pressure

WARNING**Pressure overload!**

- ▲ Death, serious bodily injury, damage to property.
- ▶ The pump must be operated according to the order data.
- ▶ Never exceed the specified maximum operating pressures.

Pump operating pressure

The maximum permissible operating pressure depends on various factors:

- pump type
- design of connections
- design of mechanical seal.

For the values that apply to your pump, please refer to the order documents.

4. Mounting, installation and connection

Overview

This section describes how to mount, install and connect the pump. You get to know what to consider when you connect the pump to the electric mains supply and how to improve the flow in order to avoid dry running of the shaft seals.

4.1 Inspection before pump installation

4.1.1 How to check free running of the impeller

1. Remove motor shroud (if applicable).
2. Remove fan cover of motor.
3. Consider direction of rotation (arrow).
4. Rotate shaft slowly by hand via the fan.

The shaft must rotate easily. If the impeller rubs against the pump housing, it has been damaged (for example during transport).

If the impeller rubs against the housing, contact HILGE Service.

If the impeller runs freely:

5. Re-fit fan cover of the motor.
6. Re-fit motor shroud (if applicable).

4.2 Set-up and alignment of the pump

WARNING**Misalignment of the pump due to improper foundation!**

- ▲ Death, serious bodily injury, damage to property.
- ▶ Ensure that the foundation on which the pump is set up is clean and flat and has sufficient load capacity.
- ▶ The mounting points provided must be bolted to the foundation according to the standard rules of mechanical engineering to ensure the satisfactory set-up of the pump.

Align the pump in this way

1. Use an engineer's spirit level laid across the machined surface of the discharge port to align the pump.
2. After aligning the pump, tighten the mounting bolts uniformly in a crosswise manner.

4.3 Installation in the pipeline

WARNING**Mechanical overload!**

- ▲ Death, bodily injury, damage to property.
- ▶ Do not use the pump or its connecting sleeves to support the pipeline (EN 809 5.2.1.2.3 and EN ISO 14847).
- ▶ In addition to the general rules of machine-building and system construction, also follow the instructions provided by the manufacturer of the connecting elements used (e.g. flanges) when installing the pump in the pipeline or system. These specifications will contain data on torques, maximum permissible angular offset and tools/ auxiliary materials to be used.
- ▶ After connecting the pipes, check the alignment of the coupling.
- ▶ It is absolutely necessary to avoid twisting the pump.

CAUTION**Mechanical overload due to foreign objects!****Caution**

- ▲ Damage to property.
- ▶ The suction and discharge ports are sealed with sheets of plastic, and the flushing and drain lines with plastic caps. These must be removed before the pump is installed in the system.

CAUTION

Dry running!

- ▲ Damage to property.
- ▶ The suction line must be absolutely leakproof and laid in such a way that no air pockets can form.
- ▶ Avoid tight elbows and valves immediately upstream of the pump. They will interfere with the incoming flow to the pump and thus with the NPSH of the system.
- ▶ The nominal pipe diameters of the system should be equal to or greater than the connectors of the pump.
- ▶ A foot valve should be used in suction operation mode.
- ▶ To prevent air pockets from forming, the suction line must be laid so that it rises to the pump, whereas a gravity feed line must be laid with a slight downward gradient to the pump.
- ▶ If local conditions do not allow the suction line to ascend continuously, install a venting device at the highest point of the line.
- ▶ An isolating valve should be installed in the suction line near the pump. This valve must be completely open during operation and may never be used as a control valve.
- ▶ An isolating valve should be installed in the discharge line, near the pump, to control the flow rate.

Caution

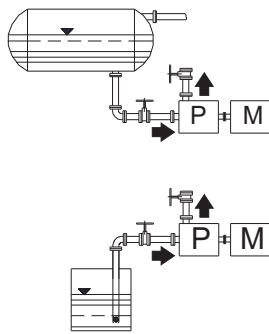

Fig. 5 Installation in the pipeline

Above: gravity feed mode | **below:** suction operation mode | **P** - pump | **M** - motor

4.3.1 Operation of the mechanical seal

Mechanical seals require a lubricating film in the sealing gap which prevents contact between the two sliding surfaces. Generally, this lubricating film consists of the pumped liquid or an externally supplied flushing or barrier liquid.

Due to the frictional heat between the sliding surfaces, the lubricating film will evaporate to the atmosphere. If the pumped liquid is water, watery liquids or volatile liquids, the leakage will thus not be visible. For perfect operation, the amount of leakage is usually only a few ml/h, but - depending on other circumstances - it may rise.

Particularly during the run-in period, and independent of size, shape or design, mechanical shaft seals may discharge a low leakage. In some cases it may be necessary to tolerate a small, visible leakage or to counteract this with appropriate measures.

Dry running

To achieve a proper sealing, mechanical seals require a lubricating film between the sliding surfaces.

Dry running occurs if the lubricant film between the sliding surfaces is missing or wears away. The frictional heat generated by direct contact of the sliding surfaces will damage the mechanical seal. Depending on the material combination, this will happen within a few seconds. (see fig. 6).

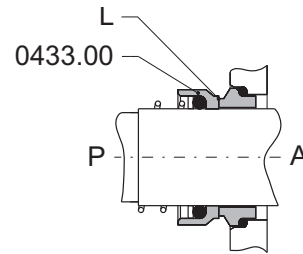

Fig. 6 Lubricating film between the sliding surfaces

P Pump side | **A** Atmospheric side

L Lubricating film | 0433.00 Mechanical seal

4.3.2 Space requirements

WARNING

Overheating!



- ▲ Damage to property.
- ▶ Ensure sufficient ventilation.
- ▶ Make sure not to reabsorb warm cooling air. Consider other heat sources in the area.
- ▶ Maintain minimum distances.

Pay attention to motor power. Maintain the minimum distances.

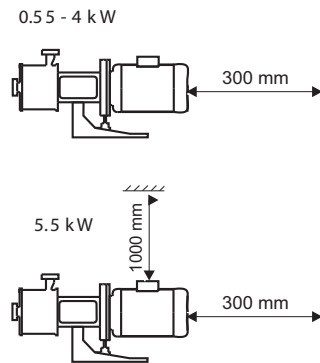

Fig. 7 Minimum distances

TM05 6442 4912

TM05 6444 4912

TM05 1038 3112

4.3.3 Reduction of noise and vibration

Noise and vibration are generated by the flow in pipes and fittings. The effect on the environment depends on correct installation and the state of the rest of the system. One way of reducing noise and vibrations is by installing expansion joints.

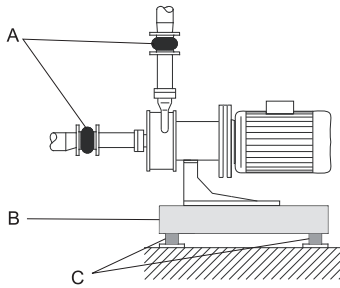

Fig. 8 Expansion

- A - expansion joints
- B - foundation
- C - vibration dampers.

Function of expansion joints:

- Dampening of expansions/contractions in the pipework caused by changing the temperature of the pumped liquid
- reduction of mechanical strains in connection with pressure surges in the pipework
- insulation of mechanical structure-borne noise in the pipework (only rubber bellows expansion joints).

Do not install expansion joints to compensate for inaccuracies in the pipework such as centre displacement of flanges. Fit expansion joints at a distance of minimum 1 to 1½ times the nominal flange diameter away from the pump on the suction as well as on the discharge side. This will prevent the development of turbulence in the expansion joints, resulting in better suction conditions and a minimum pressure loss on the pressure side. At high viscosity or velocities, we recommend that you install larger expansion joints corresponding to the pipework.

WARNING

Vibration!



- ▲ Damage to property.
- ▶ Make sure that pipes and pumps are fixed firmly to foundation or building. Insufficiently rigid structures may cause oscillations if operating conditions are changed, e.g. by fluctuations in hydraulic and/or motor forces.

Vibrations may have the following effects:

- damage to pump and motor bearings
- damage to the mechanical shaft seal
- increased coupling wear
- damage to shaft/hub connections
- cracks in the pump connections
- loosening bolts
- cable breaks at the motor connection
- tarnishing of impeller caused by friction heat.

4.4 Connection of flushing system

4.4.1 Double mechanical seal

HILGE pumps with double mechanical seal are equipped with a cartridge seal.

Depending on the seal design, the barrier or flushing liquid flows inside this cartridge seal.

The connection must be carried out as shown in fig. 9 to ensure that the liquid is able to flush the mechanical seal effectively.

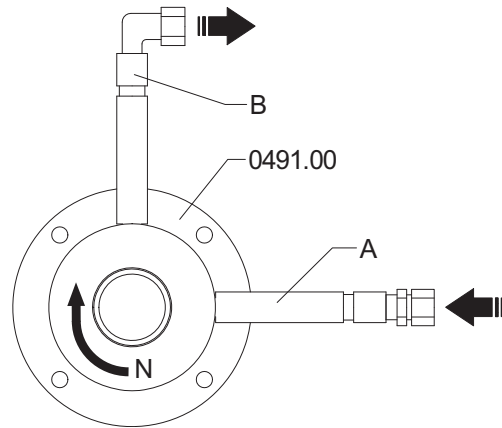

Fig. 9 Connection of flushing system

0491.00 - cartridge seal

A - feed line

B - outlet line

N - direction of rotation.

WARNING

Dry running!



- ▲ Damage to property!
- ▶ Connect the lines of the flushing system so as to guarantee a liquid supply.
- ▶ Always keep the filling level of the liquid pot between the upper and lower marks.
- ▶ In case of unpressurised flushing, ensure that the pressure in the cartridge seal never exceeds 0.2 bar.

Connect the flushing system in this way:

1. Connect feed line A. Note the dependence between arrangement and direction of rotation. See fig. 9.
2. Connect outlet line B.
3. Check tightness of connections.

4.4.2 Double mechanical seal - tandem arrangement

Flushing liquid

To continue functioning, the mechanical seals require a flushing liquid, some of its purposes being:

- preventing leaks
- protecting against dry-running
- lubricating and cooling the mechanical seals
- cutting off the air from substances which react unfavourably with oxygen.

Use a pure flushing liquid which is compatible with the pumped liquid.

Ensure proper functioning in this way:

1. Open feed line for flushing liquid.
2. Bleed cartridge seal.
3. Ensure unpressurised circulation.

Use a pure flushing liquid which is compatible with the pumped liquid.

In case of abrasive liquids, provide a reservoir into which the flushing liquid is discharged directly.

4.4.3 Double mechanical seal, back-to-back arrangement

Barrier liquid

In order to ensure proper functioning, the mechanical shaft seals require a barrier liquid. The purpose of the barrier liquid is:

- pressurising the seal chamber
- preventing the pumped liquid from penetrating into the sealing gaps
- protecting against dry-running
- lubricating and cooling the mechanical shaft seals.

TM05 6445 4912

TM05 6446 4912

Use a pure barrier liquid which is compatible with the pumped liquid.

How to ensure proper functioning:

1. Open feed line of barrier liquid.
2. Bleed cartridge seal.
3. Ensure liquid is circulating at required pressure.

The pressure of the barrier liquid should be at least 1.5 - 2 bar above the highest pressure of the pumped liquid. The temperature of the barrier liquid should not be above 60 °C on exit and should on no account exceed the boiling point.

4.5 Electrical connections

WARNING
Electric shock!



- ▲ Death, serious bodily injury.
- ▶ The electrical connections must be made by a qualified electrician.
- ▶ VDE specifications and any local regulations must be followed, especially those pertaining to safety measures.

DANGER
Motors with frequency converters (Tronic) - risk of electric shock from live parts!



- ▲ Death and serious bodily injury.
- ▶ Even if the power supply is switched off, touching electrical components can lead to electric shock.
- ▶ Before touching electrical components, disconnect the power supply and wait at least four minutes.

WARNING
Capacity overload!



- ▲ Death, serious bodily injury, damage to property.
- ▶ Check that the operating voltage corresponds to the voltage stated on the nameplate of the motor!
- ▶ Install an electrical circuit breaker.

CAUTION
Transients during frequency converter operation



- ▲ Damage to property.
- ▶ Use a motor which is suitable for frequency converter operation.
- ▶ Use a dU/dt filter or a motor with reinforced windings to avoid transients.

4.5.1 Star connection

Star connection of three-phase system for high voltage. Connect the pump as specified in the order documents. The figure below shows star connection.

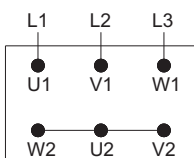

Fig. 10 Star connection

4.5.2 Delta connection

Delta connection for low voltage. Connect the pump as specified in the order documents. The figure below shows delta connection.

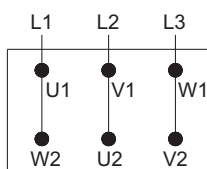

Fig. 11 Delta connection

4.5.3 Frequency converter operation

All three-phase motors can be connected to a frequency converter. Frequency converter operation can subject the motor insulation to enhanced strain. This may lead to more motor noise than normal as a result of eddy currents caused by transients.

Large motors operated via a frequency converter are subject to bearing currents. For motors size 37 kW and higher in pumps that are operated by an external frequency converter, HILGE recommends the use of insulated motor bearings to avoid increased wear of motor bearings by bearing currents.

Please consider the following operating conditions if the pump is operated using a frequency converter:

Operating conditions	Actions
Noise-sensitive applications	Install a dU/dt filter between the motor and the frequency converter (reduces transients and thus also noise).
Highly noise-sensitive applications	Install a sinus filter.
Cable length	Use a cable that satisfies the conditions specified by the frequency converter manufacturer. The length of the cable between the motor and the frequency converter impacts motor load. Keep the cable as short as possible. Use a sinus filter for cable lengths of 150 m and up.
Supply voltage up to 500 V	Check if the motor is suitable for frequency converter operation.
Supply voltage between 500 V and 690 V	Install a dU/dt filter between the motor and the frequency converter (reduces transients and thus also noise), or check whether the motor has reinforced insulation.
Supply voltage of 690 V and up	Install a dU/dt filter between the motor and the frequency converter and check whether the motor has reinforced insulation.

Please follow the manufacturer's instructions when installing and operating a frequency converter.

4.5.4 Checking the direction of rotation after connection

CAUTION
Danger of dry running!



- ▲ Damage to property.
- ▶ Before checking the direction of rotation, fill and vent the pump.
- ▶ Connect the motor and briefly (for about 2 seconds) check the direction of rotation. Note the direction-of-rotation arrow (red) on the pump. If the pump turns in the wrong direction, the mechanical seal can be destroyed.

Check the direction of rotation in this way:

1. After electrical connection, mount all safety equipment again.
2. Check tightness of hydraulic connection.
3. Open isolating valves.
4. Fill pump (system).
5. Observe the direction-of-rotation arrow.
6. Switch on motor for a short time (1-2 seconds).
7. Compare directions (motor/arrow).
8. Correct connection if necessary.

Operation with frequency converter

See the manufacturer's documentation.

TM05 6448 4912

TM05 6447 4912

5. Start-up / shut-down

Overview

This section describes how to start up and shut down the pump. You get to know which inspections contribute to failure-free operation and increased life of the pump.

5.1 Start-up

5.1.1 Check application conditions

Check the application conditions of the pump in this way:

1. Compare the data of the following documents with the provided application conditions of the pump:
 - purchasing documents (confirmation of the order)
 - nameplate
 - operating manual.
2. Make sure that the pump will operate under the specified conditions only. These conditions apply to (e.g.) pressure, temperature, and pumped liquid.

5.1.2 Starting up the pump

Start-up the pump in this way:

1. Check tightness of connection.
2. Make sure that all safety equipment is installed.
3. Make sure that all electrical connections are correct.
4. Open the isolating valves in the system.
5. Fill the pump together with the system.
6. Vent the pump and system.
7. Fully open the isolating valve on the suction side.
8. Close the isolating valve on the discharge side.
9. Start the pump.
10. Slowly open the isolating valve on the discharge side.

CAUTION

Overheating and pressure overloading!

- ▲ Damage to property.
- ▶ Never operate the pump against a closed isolating valve. Operation with a closed isolating valve must on no account continue for longer than 30 seconds.
- ▶ Never exceed the permissible operating conditions.

Caution

If the discharge head does not rise after the pump has been turned on:

1. Switch off the pump.
2. Vent the pump (system) again.
3. Repeat steps 7. to 10.

5.1.3 Functional check of the mechanical seal

Check the function of the mechanical seal in this way:

1. Watch the pump and check the mechanical seal for fault-free functioning (leak test).
2. An intact mechanical seal works virtually without leakage.

If the pumped liquid or flushing liquid leaks:

1. Switch off the pump.
2. Replace the mechanical seal.

Observe safety instructions in chapter 6.1.

5.2 Shutting down the pump



WARNING

Pressure surge!

- ▲ Death, serious bodily injury, damage to property.
- ▶ Always close isolating valves slowly!

A pressure surge is an abrupt pressure increase in the system. This pressure increase can, for example, be caused by a quick blocking of the flow in the discharge pipe. In the event of a pressure surge the maximum permissible pump pressure is temporarily exceeded considerably.

Shut down the pump in this way:

1. Switch off the pump.
2. Close the isolating valve on the discharge side.
3. Close the isolating valve on the suction side.
4. Switch off the flushing system (if applicable).
5. Make sure that the pump is depressurised.
6. Switch off the pressure in the barrier system (if applicable).

5.2.1 Cleaning the pump after shut-down

CAUTION

Caution

Jamming!

- ▲ Damage to property.
- ▶ Clean the pump appropriately after shut-down.

6. Maintenance/servicing

Overview

This section gives important information about maintenance and servicing of the pump. Read this section before you carry out maintenance work or troubleshooting measures!

6.1 Safety instructions for installation, inspection and maintenance work

WARNING

Unprofessional work!



- ▲ Death, bodily injury, damage to property.
- ▶ The operations manager must ensure that all installation, inspection and maintenance work is carried out by authorised and qualified technical personnel, who have acquired the required knowledge through study of the operating instructions.

DANGER

Electric shock if electrical parts are touched!



- ▲ Death, bodily injury.
- ▶ Always turn off the power supply to the pump before rectifying any fault.

DANGER

For motors with frequency converters (Tronic) - risk of electric shock from live parts!



- ▲ Death and serious bodily injury.
- ▶ Even if the power supply is switched off, touching electrical components can lead to electric shock.
- ▶ Before touching electrical components, disconnect the power supply and wait at least four minutes.

WARNING

Pressurised spray!



- ▲ Death, bodily injury, damage to property.
- ▶ Depressurise the pump before rectifying any fault.

WARNING

Hot components!



- ▲ Death, bodily injury, damage to property.
- ▶ Always allow the pump to cool down before rectifying any fault.

WARNING**Unintentional switching on of the pump!**

- ▲ Death, bodily injury, damage to property.
- ▶ Take appropriate measures to ensure that the pump cannot be unintentionally turned on again.

WARNING**Contact with or inhalation of hazardous substances!**

- ▲ Death, bodily injury, damage to property.
- ▶ Pumps or systems which convey hazardous liquids must be decontaminated.

WARNING**Missing protection and safety equipment!**

- ▲ Death, bodily injury, damage to property.
- ▶ Immediately after completing the work, re-install the protection and safety equipment and make sure it functions correctly.

CAUTION**Unsuitable tools!****Caution**

- ▲ Damage to property.
- ▶ In accordance with the design standard (3A0.01 to 3A3.37), ensure that all parts of the pump can be assembled without damage (e.g. scratches).
- ▶ Use HILGE assembly tool kit.

CAUTION**Frost!****Caution**

- ▲ Damage to property.
- ▶ When there is danger of frost, drain the pump completely.

6.2 Maintenance of the pump

The pump is a low-maintenance pump. In addition to cleaning, the only point to be kept in mind is the wear to the rotating mechanical seal.

6.3 Maintenance of the motor**6.3.1 Motors without lubrication fittings**

Motors without lubrication fittings are greased for life. The grease service lifetime is based on the bearing service lifetime. The prerequisite is that the motor is used according to catalogue specifications.

6.3.2 Motors with lubrication fittings

On motors equipped with lubrication fittings, information regarding re-lubrication intervals, grease types, grease volumes and additional information as needed is listed on the lubricating plate or nameplate.

DE	1	NDE	5
Grease	2	Quantity	6 g
T _{amb}	3	Interval	7 h
T _{amb}	4	Interval	8 h

Fig. 12 Example of lubricating plate, MGE motor

- 1 - drive-end bearing
- 2 - grease type
- 3 - ambient temperature
- 4 - ambient temperature
- 5 - non-drive-end bearing
- 6 - grease quality
- 7 - lubricating interval
- 8 - lubricating interval.

TM04 2075 1908

6.4 Maintenance of the Adapta® bearing housing

6.4.1 Bearing housing

Different bearing housing sizes are used depending on the size of the pump and motor. Sizes 1 and 2 are identical. Please see chapter [Design of bearing housing, sizes 1 and 2](#) and chapter [Design of bearing housing, size 3](#) for information regarding bearing housing design.

Bearing replacement

In order to ensure proper pump operation, please replace the bearing after approximately 15,000 to 20,000 operating hours.

Premature bearing replacement

In case of enduring, external impacts causing wear, such as dust, splashing water, corrosive ambient air and high temperatures, we recommend you to replace bearings after approximately 5000 operating hours.

Grease

The cavities between the rolling bodies of the bearings are completely filled with grease from factory. The grease is encapsulated by V-rings 0507.02 and 0507.05, and is intended for normal environmental conditions. The following chapters list the grease volumes to be observed during installation.

Grease types

We recommend that you use the greases listed below or verified equivalents to lubricate the roller bearings.

Manufacturer	Bearing temperature ≤ 120 °C	Bearing temperature ≤ 60 °C - risk of water ingress
ARAL	HL 3	FM 3
BP	BP ENERGREASE LS 3	ENERGREASE PR 3 ENERGREASE LS 3
CALTEX	CALTEX MULTIFAK 2	CALTEX CUP GREASE 3 CALTEX MULTIFAK 2
ESSO	BEACON 3 UNIREX N3	ESTAN 2 R BEACON 3 UNIREX N3
GULF	GULFCROWN GREASE No. 2 GULFCROWN GREASE No. 3	GULFCROWN GREASE No. 2 GULFCROWN GREASE No. 3
MOBIL - OIL	MOBILUX GREASE No. 3	GARGOYLE GREASE B No.3 MOBILUX GREASE No. 3
SHELL	SHELL ALVANIA FETT 3	SHELL UNEDO FETT 3 SHELL ALVANIA FETT 3
VALVOLINE	VALVOLINE LB 2	VALVOLINE LB 2
OKS	OKS 4200 (> 120 / ≤ 180 °C)	
SKF	LGMT 3/1	LGMT 3/1

6.4.2 Design of bearing housing, sizes 1 and 2

The bearing housing has two angular-contact ball bearings. They are arranged in pairs and are installed in an O-type configuration as fixed bearings to absorb axial and radial forces from all directions.

Grease volumes for roller bearings during installation

This information pertains to complete filling of the bearings.

Bearing housing size	1	2
Part no.	0326.00	0326.00
Number of bearings	2	2
Volume [cm ³]	9	25
Quantity [g]	8.5	23.7

6.4.3 Design of bearing housing, size 3

The bearing housing has two angular-contact ball bearings 0326.00 and a cylindrical roller bearing 0327.00. The two single-row angular-contact ball bearings make up the motor-side bearing. They are arranged in pairs and are installed as fixed bearings in an X-type configuration to absorb axial and radial forces from all directions.

The pump-side bearing consists of a single-row cylindrical roller bearing absorbing only radial bearing forces. The bearing permits axial movements in both directions.

Grease quantities for roller bearings during assembly

This information pertains to complete filling of the bearings.

Size	3
Part no.	0326.00 + 0327.00
Number of bearings	2+1
Volume [cm ³]	33
Weight [g]	31.25

Relubrication of the bearings

Lubricate the roller bearings according to the following table. The values indicated refer to normal operating conditions.

CAUTION		
Incorrect lubrication of roller bearings!		
Caution	▲	Damage to property.
	▶	Make certain to avoid applying too much or too little grease to the bearings!
Bearing	Lubricating intervals [hours]	Weight [g]
0326.00	Approx. 1,000	11
0327.00	Approx. 3,000	10

6.5 Assembly

DANGER



Disregard of instructions!

- ▲ Death, bodily injury or damage to property.
- ▶ Before assembly or maintenance work of the pump, see section 6.1.

6.5.1 Parts overview, MAXA pump sizes 65-160/200

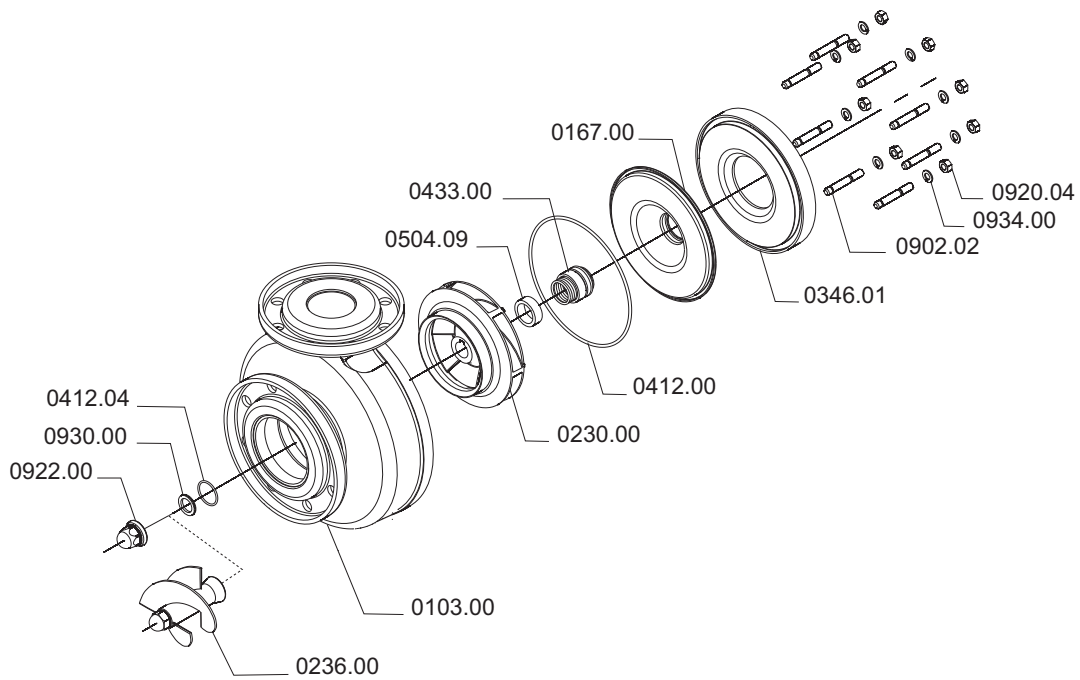

Fig. 13 Parts overview

Qty.	Part no.	Description
1	0103.00	Pump housing
1	0167.00	Backplate liner
1	0230.00	Impeller
1	0236.00	Inducer (optional)
1	0346.01	Intermediate ring
1	0412.00	O-ring
1	0412.04	O-ring

Qty.	Part no.	Description
1	0433.00	Mechanical shaft seal
1	0504.09	Spacer ring
8	0902.02	Stud
8	0920.04	Hexagon nut
1	0922.00	Impeller nut
2	0930.00	Lock washer
8	0934.00	Spring washer

TM05 9008 0614

6.5.2 Parts overview, MAXA pump sizes 80, 100, 65-250

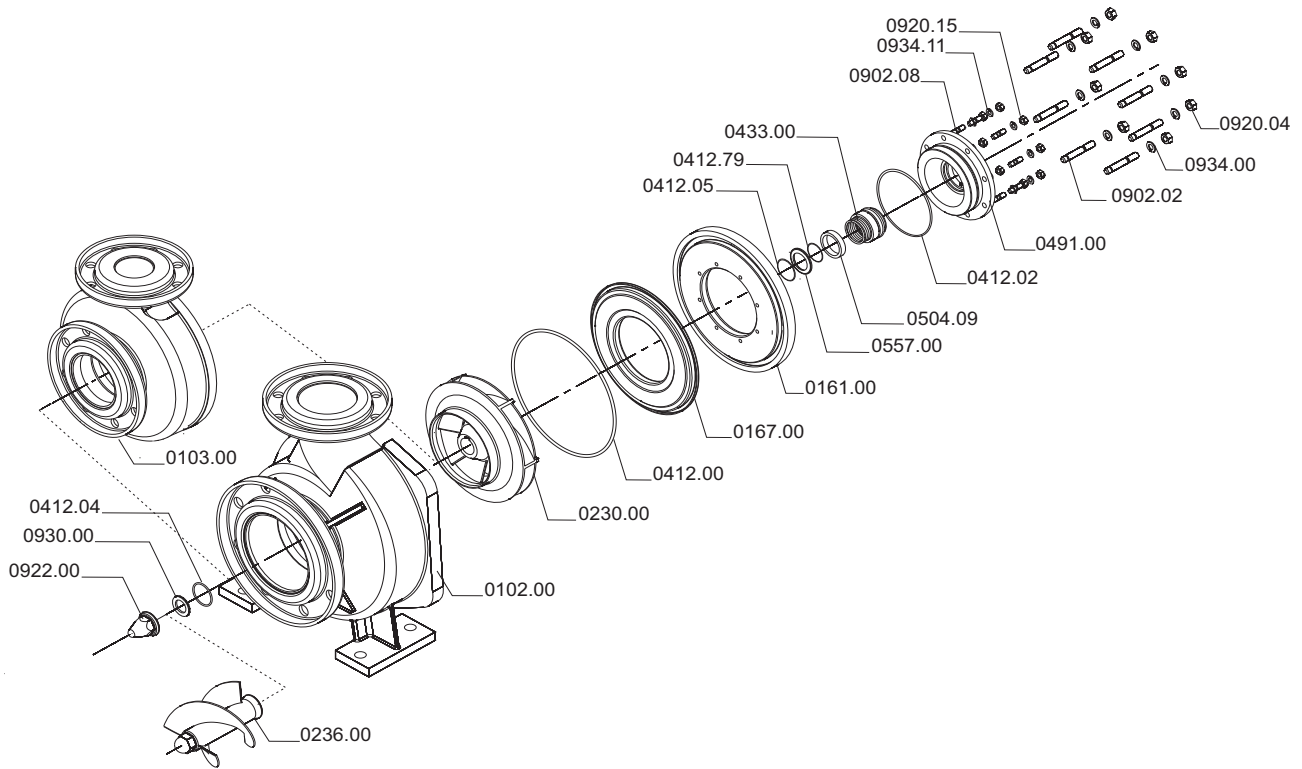

Fig. 14 Parts overview

Qty.	Part no.	Description
1	0102.00	Volute casing
1	0103.00	Pump housing
1	0161.00	Backplate
1	0167.00	Backplate liner (not for sizes below 125)
1	0230.00	Impeller
1	0236.00	Inducer (optional)
1	0412.00	O-ring
1	0412.02	O-ring
1	0412.04	O-ring
1	0412.05	O-ring (only size 80-200 and above)
1	0412.79	O-ring (only size 80-200 and above)
1	0433.00	Mechanical shaft seal

Qty.	Part no.	Description
1	0491.00	Cartridge seal
1	0504.09	Spacer ring
1	0557.00	Seal spacer (only size 80-200 and above)
8	0902.02	Stud
8	0902.08	Stud
8	0920.04	Hexagon nut
8	0920.15	Hexagon nut
1	0922.00	Impeller nut
2	0930.00	Lock washer
8	0934.00	Spring washer
8	0934.11	Spring washer

TM05 9009 0814

6.5.3 Bearing housing, sizes 1 and 2

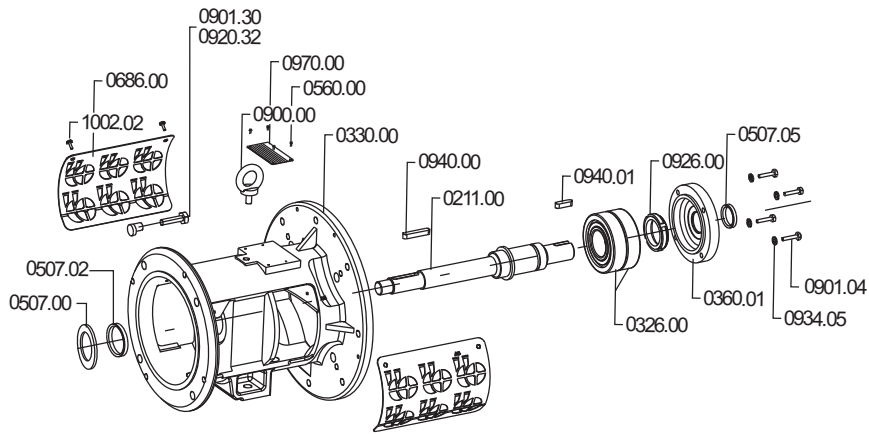

Fig. 15 Parts overview, bearing housing up to motor size 180

Qty.	Part no.	Description
1	0211.00	Pump shaft
2	0326.00	Angular-contact ball bearing
1	0330.00	Bearing housing
1	0360.01	Bearing cover
1	0507.00	Deflector
1	0507.02	Deflector (V-ring)
1	0507.05	Deflector (V-ring)
4	0560.00	Pin
2	0686.00	Guard
1	0900.00	Screw

Qty.	Part no.	Description
4	0901.30	Hexagon head screw
4	0901.04	Hexagon head screw
4	0920.32	Hexagon nut
1	0926.00	Grooved nut
4	0934.05	Spring washer
1	0940.00	Key
1	0940.01	Key
1	0970.00	Nameplate
4	1002.02	Pan-head slotted screw

TM06 1130 1814

6.5.4 Bearing housing, size 3

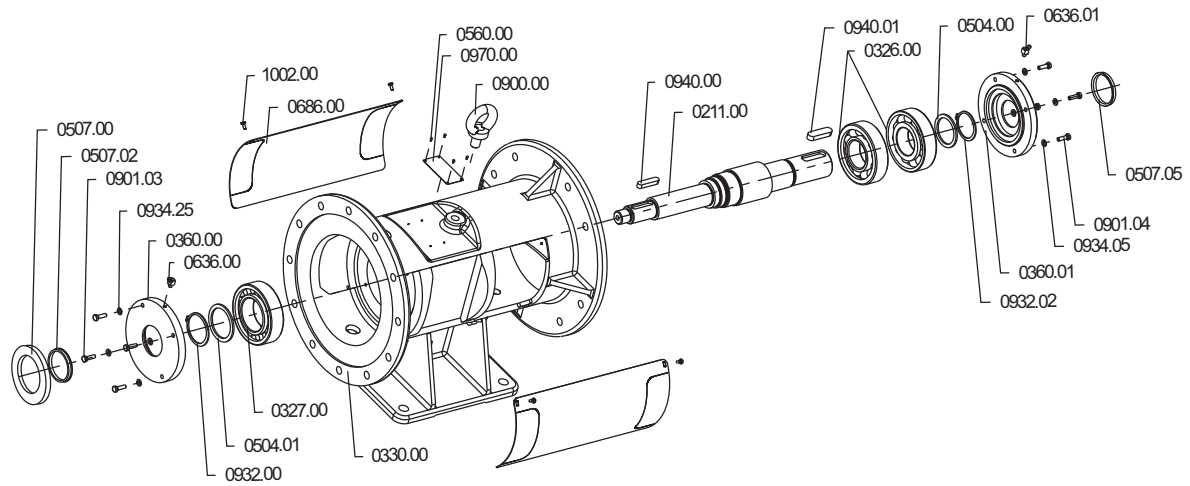

Fig. 16 Parts overview, bearing housing from motor size 200

Qty.	Part no.	Description
2	0326.00	Angular-contact ball bearing
1	0327.00	Cylindrical roller bearing
1	0330.00	Bearing housing
1	0360.00	Bearing cover
1	0360.01	Bearing cover
1	0504.00	Spacer ring
1	0507.00	Deflector
1	0507.02	Deflector (V-ring)
1	0507.05	Deflector (V-ring)
4	0560.00	Pin
1	0636.00	Grease nipple
1	0636.01	Grease nipple
2	0686.00	Guard

Qty.	Part no.	Description
1	0900.00	Screw
4	0901.03	Hexagon head screw
4	0901.04	Hexagon head screw
4	0920.09	Hexagon nut
1	0932.00	Circlip
1	0932.02	Circlip
4	0934.05	Spring washer
4	0934.25	Spring washer
1	0940.01	Key
1	0940.00	Key
1	0970.00	Nameplate
4	1002.00	Pan-head slotted screw

TM06 1131 1814

6.5.5 Coupling and motor

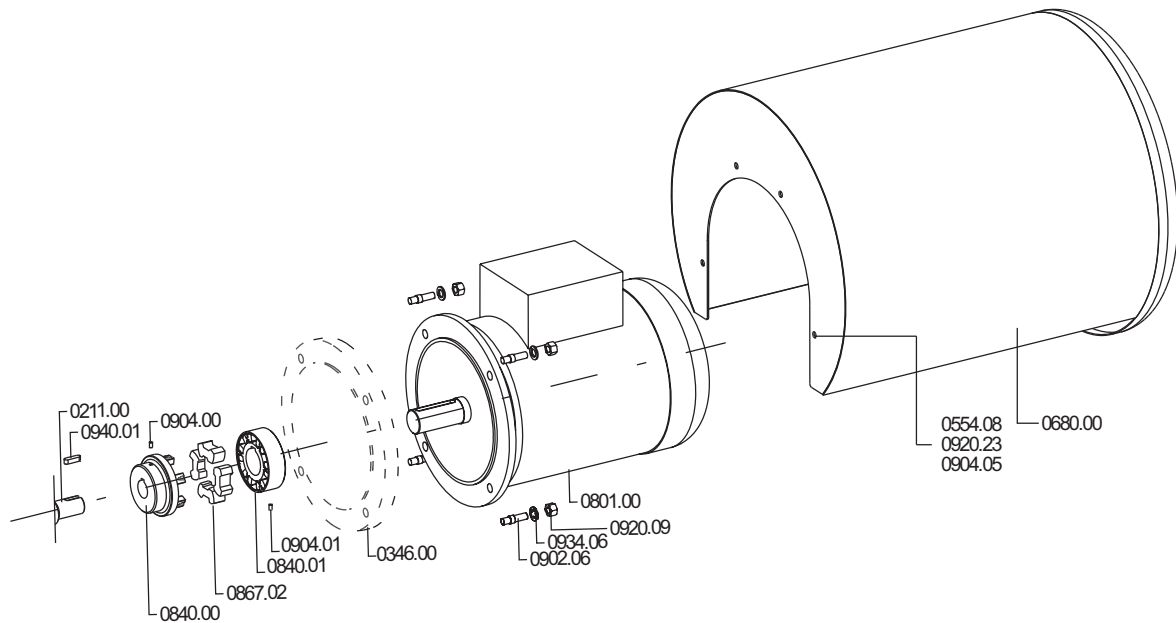

Fig. 17 Parts overview, coupling and motor

Qty.	Part no.	Description
1	0211.00	Pump shaft
1	0346.00	Intermediate ring
4	0554.08	Washer
1	0680.00	Shroud (SUPER-version only)
1	0801.00	Motor
1	0840.00	Coupling
1	0840.01	Coupling
1	0867.02	Coupling insert

6.5.6 Instructions for disassembly



DANGER

Disregarding important instructions!

- ▲ Death, serious bodily injury, damage to property.
- ▶ Before you disassemble the pump, note section [6.1 Safety instructions for installation, inspection and maintenance work](#) on page 16.

CAUTION

Important!

Caution

- ▲ Damage to property.
- ▶ Use tools from the HILGE assembly tool kit in order to disassemble the pump without damage and scratches.

TM05 2740 0912

Qty.	Part no.	Description
4	0902.06	Stud
1	0904.00	Set screw
1	0904.01	Set screw
4	0904.05	Set screw
4	0920.23	Hexagon nut
4	0920.09	Hexagon nut
4	0934.06	Spring washer
1	0940.01	Key

6.5.7 Instructions for assembly



DANGER

Disregarding important instructions!

- ▲ Death, serious bodily injury, damage to property.
- ▶ Before you assemble or do maintenance work on the pump, note section [6.1 Safety instructions for installation, inspection and maintenance work](#) on page 16.

CAUTION

Important!

- ▲ Damage to property.
- ▶ Use tools from the HILGE assembly tool kit in order to assemble the pump without damage or scratches.
- ▶ To ensure a good sealing, use only O-ring seals with the original dimensions.
- ▶ Never use grease containing mineral oil when assembling the wet-end parts. Wet-end parts come into contact with the pumped liquid.
- ▶ When replacing mechanical seals, always replace all parts.
- ▶ To tighten impeller nut 0922.00, use either a screw device or the impeller nut installing device as the torque applied to tighten it must be absolutely concentric. Otherwise the pump shaft 0211.00 will be bent.

Caution

6.5.8 Assembly of the bearing housing, sizes 1 and 2

1. Slide the angular-contact ball bearings 0326.00 onto the pump shaft 0211.00. If the bearings have been replaced, replace the grooved nut. Lock the bearings 0326.00 by tightening the grooved nut 0926.00. Torque: 120-140 Nm.



MF-426

Fig. 18 Shaft, bearings and grooved nut

2. Fill the cavities of the bearing 0326.00 to about 100 % with grease. As you do so, observe section on page 18.



MF-398

Fig. 19 Ball bearings

3. Push the pump shaft 0211.00 into the bearing housing 0330.00.

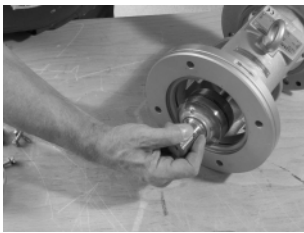

MF-696

Fig. 20 MAXA Adapta bearing housing

4. Coat the inner face of the bearing cover 0360.01 with grease. Push the bearing cover over the pump shaft 0211.00.



MF-399

Fig. 21 Bearing cover

5. Mount the bearing cover 0360.01 using spring washers 0934.05 and hexagon head screws 0901.04. Torque: 8 Nm.



MF-358

Fig. 22 Bearing cover

6. Push the V-ring 0507.05 with greased lip onto the pump shaft 0211.00; make sure that the sealing lip bears against the bearing cover 0360.01.



MF-359

Fig. 23 V-ring on motor side

7. Push the V-ring 0507.02 with greased lip onto the pump shaft 0211.00; make sure that the sealing lip bears against the bearing housing 0330.00.



MF-698

Fig. 24 V-ring on pump side

8. Insert key 0940.01 into pump shaft 0211.00. Do not use a hammer to do this! The bearings could be damaged.

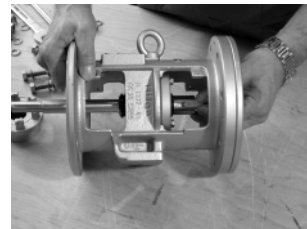

MF-360

Fig. 25 Key

-
9. Push the coupling half 0840.00 onto the pump shaft 0211.00 and align the coupling half 0840.00 to the pump shaft 0211.00.



MF-362

Fig. 26 Coupling half

10. Fix the coupling half 0840.00 by means of the set screw 0904.00. Torque: 4 Nm.



MF-363

Fig. 27 Set screw

-
11. Fit the bearing housing 0330.00 to the stainless steel foot 0180.00 using hexagon head screws 0901.00, hexagon nuts 0920.02 and spring washers 0934.02.



MF-687

Fig. 28 Stainless steel foot

12. Insert the key 0940.01 into the motor shaft.

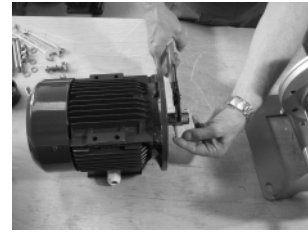

MF-688

Fig. 29 Key

-
13. Check coupling inserts 0867.02 for wear and change them where required.



MF-427

Fig. 30 Coupling inserts

14. Push the coupling half 0840.01 onto the motor shaft, align it to the motor shaft and slightly tighten the set screw 0904.01.



MF-689

Fig. 31 Coupling half on motor side

-
15. Join motor 0801.00 and bearing housing 0330.00. To do this, put the coupling halves 0840.00 and 0840.01 into each other.

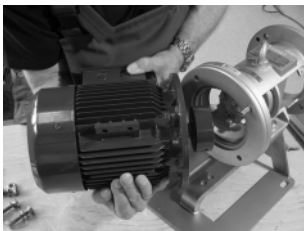

MF-686

Fig. 32 Coupling

16. Fix bearing housing 0330.00 and motor using hexagon nuts 0920.09 and spring washers 0934.06.
Torque: M10 - 37 Nm
Torque: M12 - 65 Nm



MF-690

Fig. 33 Bearing housing

-
17. Align coupling half 0840.01. The permitted axial offset of the coupling halves in relation to each other: 2-4 mm.
Check by means of a feeler gauge.
18. Fix coupling half 0840.01 using the set screw 0904.00.
Torque: 4 Nm



MF-691

Fig. 34 Feeler gauge

19. Push deflector 0507.00 onto the pump shaft 0211.00.
Mount the deflector 0507.00 in such a way that the distance to the adjacent parts eliminates contact.

Mounting can be different from the one shown.

6.5.9 Assembly the bearing housing, size 3

1. Push the outer ring of the cylindrical roller bearing 0327.00 on the pump side into the bearing housing 0330.00.

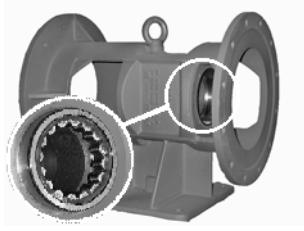

MF-589

Fig. 35 Bearing housing, cylindrical roller bearing

2. Grease the outer ring of the cylindrical roller bearing 0327.00. As you do so, observe section on page 18.

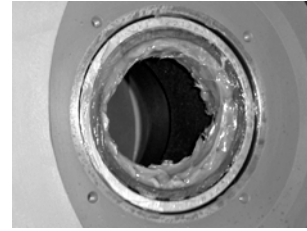

MF-383

Fig. 36 Cylindrical roller bearing

3. Grease the cylindrical roller bearing 0327.00 from the motor side of the bearing housing 0330.00. As you do so, observe section on page 18.

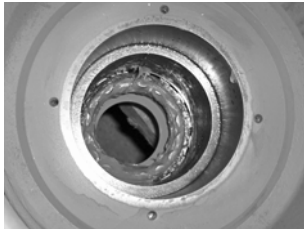

MF-585

Fig. 37 Cylindrical roller bearing

4. Push the angular-contact ball bearings 0326.00 as X-type configuration onto the pump shaft 0211.00.
5. Mount the spacer ring 0504.00 and the circlip 0932.02 on the motor side.
6. Grease the cylindrical roller bearing 0326.00. As you do so, observe section on page 18. Push the inner ring of the cylindrical roller bearing 0327.00 on the pump side onto the shaft.

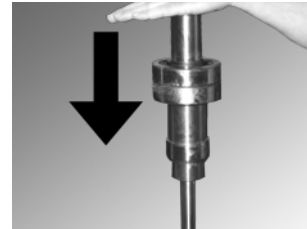

MF-570

Fig. 38 Angular-contact ball bearing

7. Push the pump shaft 0211.00 and the angular-contact ball bearings 0326.00 into the bearing housing 0330.00.

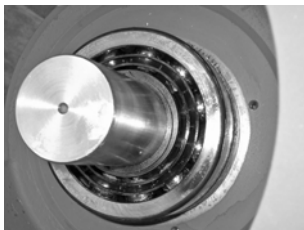

MF-590

Fig. 39 Pump shaft

8. Mount the spacer ring 0504.01 and the circlip 0932.00 on the pump side.



MF-777

Fig. 40 Circlip

9. Clean the motor side bearing cover 0360.01.
10. Coat the inner surface of the bearing cover 0360.01 with grease.
11. Mount the bearing cover 0360.01 using spring washers 0934.05 and hexagon head screws 0901.04. Torque: 10 Nm



MF-385

Fig. 41 Bearing cover

12. Clean the pump side bearing cover 0360.00.
13. Coat the inner surface of the bearing cover 0360.00 with grease.
14. Mount the bearing cover 0360.00 using spring washers 0934.25 and hexagon head screws 0901.03. Torque: 10 Nm

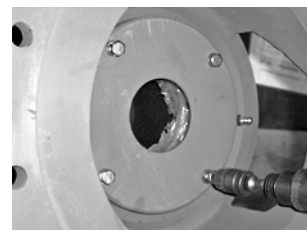

MF-384

Fig. 42 Bearing cover

15. Push the V-rings 0507.02 and 0507.05 with the greased lips onto the pump shaft; make sure that the sealing lips bear against the bearing covers 0360.00 and 0360.01.



MF-587

Fig. 43 V-ring on pump side

16. Insert the key 0940.01 into pump shaft 0211.00.
Do not use a hammer to do this. The bearings could be damaged.



MF-588

Fig. 44 Key

17. Grease the coupling seat on the pump shaft 0211.00.
Use Klüberpaste UH1 96-402 from HILGE assembly tool kit (pos. 6, fig. 15).

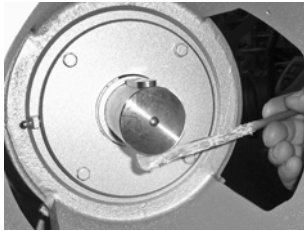

MF-572

Fig. 45 Pump shaft

18. Check coupling inserts 0867.02 for wear and change them where required.

19. Push the coupling half 0840.00 onto the pump shaft 0211.00 and align it to the pump shaft.

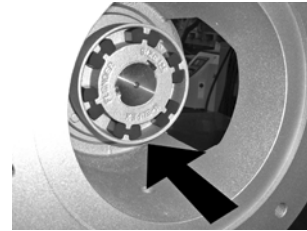

MF-571

Fig. 46 Coupling half

20. Tighten the set screw 0904.01.
Torque M4: 3 Nm.



MF-563

Fig. 47 Set screws

21. Grease the studs 0902.06. Use Klüberpaste UH1 96-402 from HILGE assembly tool kit.



MF-564

Fig. 48 Studs

22. Screw the four studs 0902.06 into the bearing housing 0330.00.



MF-552

Fig. 49 Bearing housing with studs

23. Grease the contact surfaces of bearing housing 0330.00, motor 0801.00 and the studs 0902.06. Use Klüberpaste UH1 96-402 from HILGE assembly tool kit.

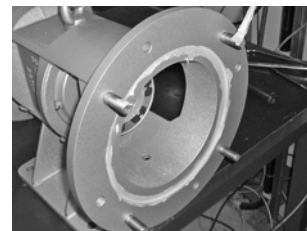

MF-565

Fig. 50 Bearing housing with studs

24. Insert the key 0940.01 into the motor shaft.



MF-961
Fig. 51 Key

25. Check coupling inserts 0867.02 for wear and change them where required.

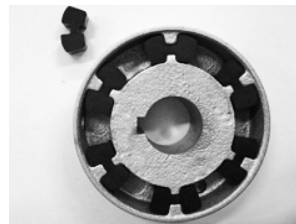

MF-959
Fig. 52 Coupling inserts

26. Push the coupling half 0840.01 onto the motor shaft, align it to the motor shaft and slightly tighten the set screw 0904.01.



MF-960
Fig. 53 Coupling half on motor side

27. Join motor 0801.00 and bearing housing 0330.00. To do this, put the coupling halves 0840.01 and 0840.00 into each other.

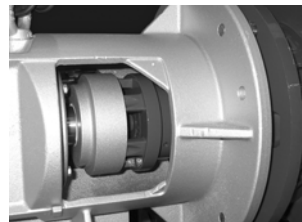

MF-566
Fig. 54 Coupling

28. Fix bearing housing 0330.00 and motor using hexagon nuts 0920.09 and spring washers 0934.06.

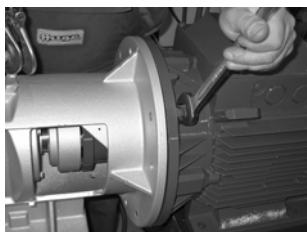

MF-567
Fig. 55 Bearing housing

29. Align the coupling 0840.00. The permitted axial offset of the coupling halves in relation to each other: 4 mm.

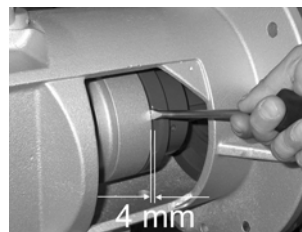

MF-569
Fig. 56 Axial offset

30. Fix the coupling half 0840.00 using the set screw 0904.00.
Torque M4: 3 Nm.

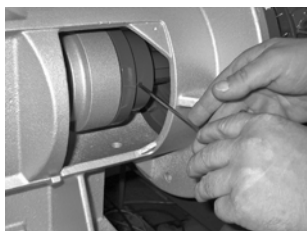

MF-568
Fig. 57 Bearing housing

In order to continue the assembly, see the following descriptions of mechanical seals.

6.5.10 Mechanical shaft seals for MAXA 80, 100, 65-250

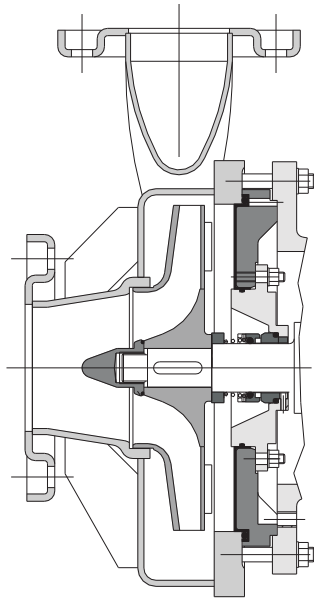

TM05 9011 0614

Fig. 58 Mechanical shaft seal

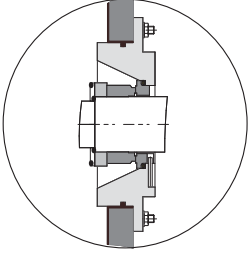
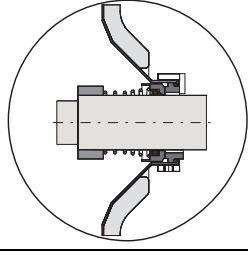
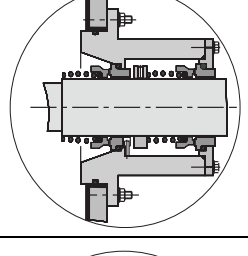
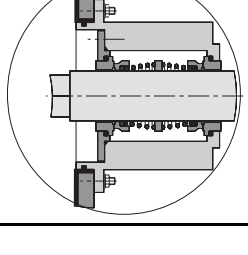
Seal type	Characteristic	Page
 TM05 9015 1014	Single Seat in cartridge seal	31
 TM05 9010 0614	Single Shaft seal in backplate liner	31
 TM05 8998 3113	Double Tandem arrangement	32
 TM05 9015 0714	Double Back-to-back arrangement	33

6.5.11 Mechanical shaft seals for MAXA 125-, 150-

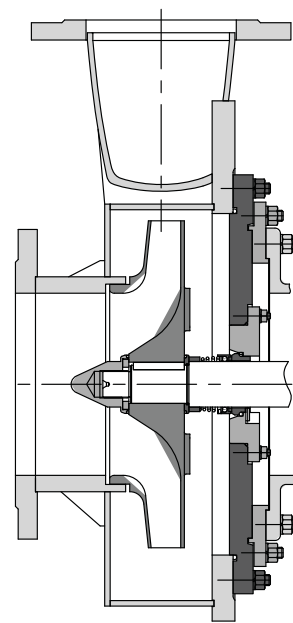

TM06 1126 1714

Fig. 59 Mechanical shaft seal

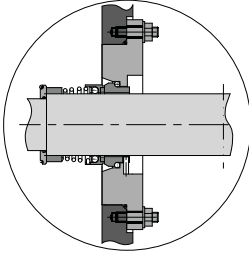
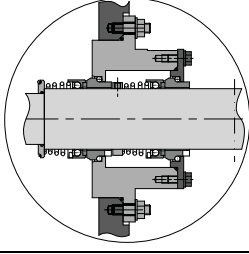
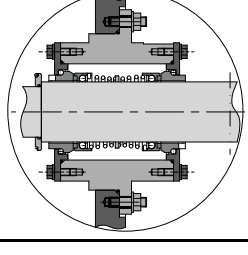
Seal type	Characteristic	Page
 TM06 1127 1714	Single Seat in cartridge seal	34
 TM06 1128 1714	Double Tandem arrangement	35
 TM06 1129 1714	Double Back-to-back arrangement	33

6.5.12 Single mechanical shaft seal, seat in cartridge seal

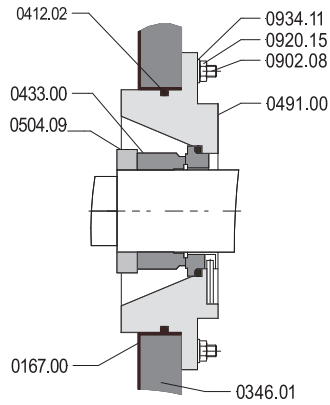

Fig. 60 Single mechanical shaft seal, seat in cartridge seal

Parts overview

- 0167.00 - backplate liner
- 0412.02 - O-ring
- 0433.00 - mechanical shaft seal
- 0491.00 - cartridge seal
- 0504.09 - spacer ring
- 0902.08 - stud
- 0920.15 - hexagon nut
- 0934.11 - spring washer.

Characteristics

- Single mechanical shaft seal
- seat in cartridge seal 0491.00
- with back plate liner 0167.00.

Prior to installation

- Check the shaft and the counter-ring seat for contamination and damage (sharp edges). Clean the parts or replace them as needed.
- Check all O-rings in the mechanical shaft seal to make sure they are properly situated, and correct them, if necessary.
- In order to reduce friction, moisten all of the O-ring sliding surfaces with water.

Assembly

1. Insert the backplate liner 0167.00 into the backplate 0161.00.
2. Insert the O-ring 0412.02 into the cartridge seal 0491.00.
3. Push the mechanical cartridge seal 0491.00 into the backplate liner 0167.00.
4. Fasten the cartridge seal 0491.00 to the backplate 0161.00. Use spring washers 0934.11 and hexagon nuts 0920.15 to do this. Torque M8: 19 Nm.
5. Grease the locating ring between the backplate 0161.00 and the bearing housing 0330.00. Use Klüberpaste UH1 84-201 from HILGE assembly tool kit.
6. Fasten the backplate 0161.00 and the cartridge seal 0491.00 to the bearing housing 0330.00.
7. Slide the assembly sleeve onto the pump shaft 0211.00 up to the stop.
8. Slide the stationary ring of the mechanical seal 0433.00 into the seat. Use the assembly sleeve from HILGE assembly tool kit to do this.
9. Slide the rotating part of the mechanical shaft seal 0433.00 onto the pump shaft 0211.00 up to the stop. Use the assembly sleeve to do this.
10. Slide the spacer ring 0504.09 onto the pump shaft 0211.00.

For assembly of the impeller and pump housing, see section [6.5.19](#) on page 37.

TM05 6454 4912

6.5.13 Single mechanical seal, seat in backplate liner

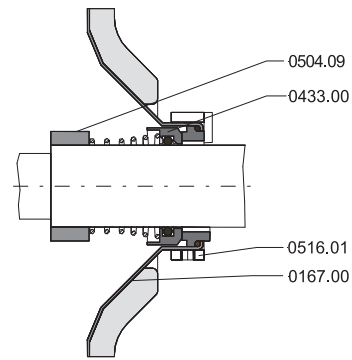

Fig. 61 Single mechanical seal, seat in backplate liner.

Parts overview

- 0167.00 - backplate liner
- 0433.00 - mechanical seal
- 0504.09 - spacer ring
- 0516.01 - locating ring.

Characteristics

- single mechanical seal
- seat in backplate liner 0167.00.

Prior to installation

- Check the shaft and the counter-ring seat for contamination and damage (sharp edges). Clean the parts or replace them as needed.
- Check all o-rings in the mechanical seal to make sure they are properly situated and correct if necessary.
- In order to reduce friction, moisten all of the O-ring sliding surfaces with water.

Assembly

1. Insert the backplate liner 0167.00 into the intermediate ring 0346.01.
2. Grease the centring between the intermediate ring 0346.01 and the motor flange 0802.00. Use Klüberpaste UH1 84-201 from the HILGE Assembly Tool Kit.
3. Mount the intermediate ring 0346.01 to the motor 0802.00.
4. Slide the assembly sleeve onto the shaft extension.
5. Push the stationary ring of the mechanical seal 0433.00 into the seat of the backplate liner 0167.00. Use an assembly sleeve to do this.
6. Push the rotating ring of the mechanical seal 0433.00 onto the shaft 0211.00. Use an assembly sleeve to do this.
7. Push the spacer ring 0504.09 onto the shaft 0211.00.

For assembly of the impeller and volute casing, see section [6.5.19 Assembly of the impeller and volute casing](#).

TM05 6453 4912

6.5.14 Double mechanical shaft seal, tandem

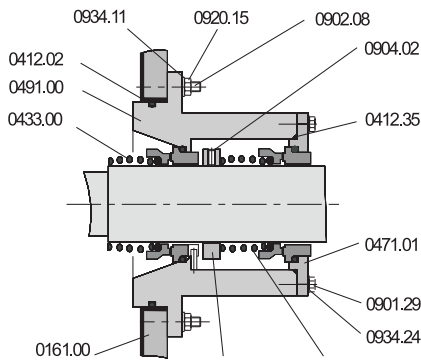

Fig. 62 Double mechanical shaft seal, tandem

Parts overview

- 0161.00 - backplate
- 0412.02 - O-ring
- 0412.35 - O-ring
- 0433.00 - mechanical shaft seal
- 0433.01 - mechanical shaft seal
- 0471.01 - seal cover
- 0491.00 - cartridge seal
- 0516.00 - locating ring
- 0901.29 - hexagon head screw
- 0902.08 - stud
- 0904.02 - set screw
- 0920.15 - hexagon nut
- 0934.11 - spring washer
- 0934.24 - spring washer.

Characteristics

- Seal cover
- cartridge seal.

Prior to installation

- Check the shaft and the counter-ring seat for contamination and damage (sharp edges). Clean the parts or replace them as needed.
- Check all O-rings in the mechanical shaft seal to make sure they are properly situated and correct them, if necessary.
- In order to reduce friction, moisten all of the O-ring sliding surfaces with water.

Assembly

1. Insert the stationary ring of the mechanical seal 0433.01 and the O-ring 0412.35 into the seal cover 0471.01.
2. Push the seal cover 0471.01 onto the shaft 0211.00.
3. Slide the assembly sleeve onto the shaft extension. Push the rotating ring of the mechanical seal 0433.01 onto the shaft 0211.00. Use an assembly sleeve to do this.
4. Turn the set screw 0904.02 one or two turns into the locating ring 0516.00. Fix the set screw with glue. Use Loctite type 243 for this.
5. Position the locating ring 0516.00 on the shaft with the correct gauge. Secure the locating ring using the set screw 0904.02.
6. Relieve the mechanical seal 0433.01 spring.
7. Grease all contact surfaces between the bearing housing 0330.00 and the backplate 0161.00. Use Klüberpaste UH1 96-402 for this.
8. Insert the O-ring 0412.02 into the cartridge seal 0491.00.
9. Push the mechanical cartridge seal 0491.00 into the backplate 0161.00 and fix it by using the washers 0934.11 and the hexagon nut 0920.15. Torque: M8 - 19 Nm.
10. Push the backplate 0161.00 into the bearing housing 0330.00. Pay attention to the correct direction of the backplate 0161.00.
11. Slide the assembly sleeve onto the shaft extension.
12. Sl the stationary ring of the mechanical seal 0433.00 into the cartridge seal 0491.00. Use an assembly sleeve to do this.

13. Push the rotating ring of the mechanical seal 0433.00 onto the shaft 0211.00. Use an assembly sleeve to do this.

14. Fix the seal cover 0471.01 onto the cartridge seal 0491.00 by using spring washers 0934.24 and hexagon head screws 0901.29. Torque: M6 - 8 Nm.

For assembly of the impeller and volute casing, see section [6.5.19 Assembly of the impeller and volute casing](#).

TM05 6752 4912

6.5.15 Double mechanical shaft seal, back to back

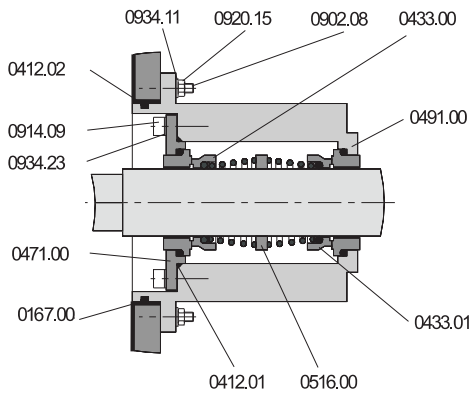

TM05 6745 2310

Fig. 63 Double mechanical shaft seal, back to back

Parts overview

- 0167.00 - backplate liner
- 0412.01 - O-ring
- 0412.02 - O-ring
- 0433.00 - mechanical shaft seal
- 0433.01 - mechanical shaft seal
- 0471.01 - seal cover
- 0491.00 - cartridge seal
- 0516.00 - locating ring
- 0902.08 - stud
- 0914.09 - hexagon socket head cap screw
- 0920.15 - hexagon nut
- 0934.11 - spring washer
- 0934.23 - spring washer.

Characteristics

- Double mechanical seal, back-to-back
- with cartridge seal.

Prior to installation

- Check the shaft and the counter-ring seat for contamination and damage (sharp edges). Clean the parts or replace them as needed.
- Check all O-rings in the mechanical shaft seal to make sure they are properly situated and correct them, if necessary.
- In order to reduce friction, moisten all of the O-ring sliding surfaces with water.

Assembly

1. Insert the O-ring 0412.02 into the cartridge seal 0491.00.
2. Fix the cartridge seal 0491.00 to the backplate 0161.00 by using spring washers 0934.11 and hexagon nuts 0920.15. Torque: M8 - 19 Nm.
3. Push the backplate 0161.00 into the bearing housing 0330.00 by using a plastic hammer.
4. Slide the assembly sleeve onto the shaft extension.
5. Slide the stationary ring of the mechanical shaft seal 0433.01 into the seat of the cartridge seal 0491.00. Use an assembly sleeve to do this.
6. Slide the rotating ring of the mechanical shaft seal 0433.01 completely assembled onto the shaft up as far as the stop.
7. Slide the locating ring 0516.00 onto the shaft 0211.00.
8. Mount the rotating ring of the product-side mechanical shaft seal 0433.00. Use an assembly sleeve to do this.
9. Insert the O-ring 0412.01 and the stationary ring of the mechanical shaft seal 0433.00 into the seal cover 0471.00.
10. Fix the seal cover 0471.00 together with the stationary ring of the mechanical shaft seal 0433.00 on the cartridge seal 0491.00 by using the spring washers 0934.23 and the hexagon socket head cap screws 0914.09. Torque: M6 - 8 Nm.

For assembly of the impeller and volute casing, see section [6.5.19 Assembly of the impeller and volute casing](#).

6.5.16 Single mechanical shaft seal, seat in cartridge seal

For assembly of the impeller and pump housing, see section 6.5.19 on page 37.

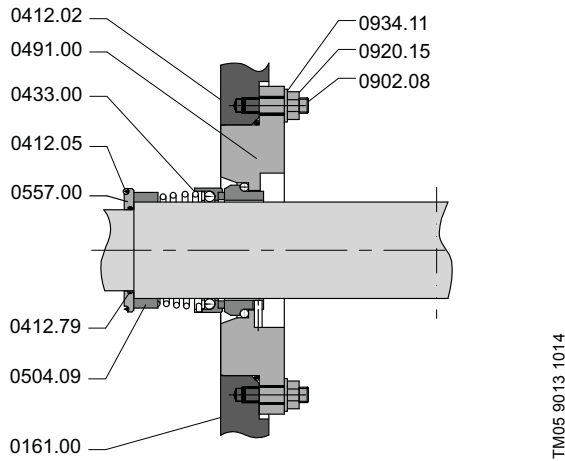

Fig. 64 Single mechanical shaft seal, seat in cartridge seal

Parts overview

- 0161.00 - backplate
- 0412.02 - O-ring
- 0412.05 - O-ring
- 0412.79 - O-ring
- 0433.00 - mechanical shaft seal
- 0491.00 - cartridge seal
- 0504.09 - spacer ring
- 0557.00 - seal spacer
- 0902.08 - stud
- 0920.15 - hexagon nut
- 0934.11 - spring washer.

Characteristics

- Single mechanical shaft seal
- seat in cartridge seal 0491.00.

Prior to installation

- Check the shaft and the counter-ring seat for contamination and damage (sharp edges). Clean the parts or replace them as needed.
- Check all O-rings in the mechanical shaft seal to make sure they are properly situated, and correct them, if necessary.
- In order to reduce friction, moisten all of the O-ring sliding surfaces with water.

Assembly

1. Insert the O-ring 0412.02 into the cartridge seal 0491.00.
2. Slide the cartridge seal 0491.00 into the backplate 0161.00.
3. Fix the cartridge seal 0491.00 to the backplate 0161.00 using spring washers 0934.11 and hexagon nuts 0920.15. Torque M8: 19 Nm.
4. Grease the locating ring between the bearing housing 0330.00 and backplate 0161.00. Use Klüberpaste UH1 84-201 from HILGE assembly tool kit.
5. Push the backplate 0161.00 into the bearing housing 0330.00. Use a plastic hammer to do this. Observe the correct mounting direction of the backplate. Grease threads of the studs 0902.02 with Klüberpaste UH1 96-402.
6. Fasten the backplate 0161.00 to the bearing housing 0330.00 using spring washers 0934.00 and hexagon nuts 0920.04. Torque M12: 65 Nm.
7. Push the assembly sleeve onto the pump shaft 0211.00 up to the stop.
8. Slide the stationary ring of the mechanical shaft seal 0433.00 into the seat. Use the assembly sleeve from HILGE assembly tool kit to do this.
9. Slide the rotating part of the mechanical shaft seal 0433.00 onto the pump shaft 0211.00 up to the stop. Use the assembly sleeve to do this.
10. Push the spacer ring 0504.09 onto the shaft.

6.5.17 Double mechanical shaft seal, tandem

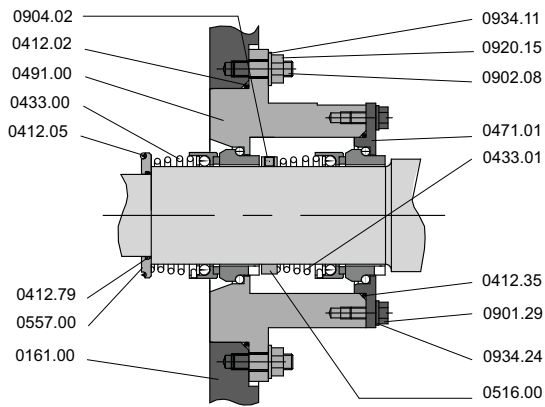

Fig. 65 Double mechanical shaft seal, tandem

Parts overview

- 0161.00 - backplate
- 0412.02 - O-ring
- 0412.05 - O-ring
- 0412.35 - O-ring
- 0412.79 - O-ring
- 0433.00 - mechanical shaft seal
- 0433.01 - mechanical shaft seal
- 0471.01 - seal cover
- 0491.00 - cartridge seal
- 0516.00 - locating ring
- 0557.00 - seal spacer
- 0901.29 - hexagon head screw
- 0902.08 - stud
- 0904.02 - set screw
- 0920.15 - hexagon nut
- 0934.11 - spring washer
- 0934.24 - spring washer.

Characteristics

- Seal cover 0471.01
- cartridge seal 0491.00.

Prior to installation

- Check the shaft and the counter-ring seat for contamination and damage (sharp edges). Clean the parts or replace them as needed.
- Check all O-rings in the mechanical shaft seal to make sure they are properly situated, and correct them, if necessary.
- In order to reduce friction, moisten all of the O-ring sliding surfaces with water.

Assembly

1. Insert the stationary ring of the mechanical shaft seal 0433.01 and the O-ring 0412.35 into the seal cover 0471.01.
2. Slide the seal cover 0471.01 onto the shaft.
3. Slide the assembly sleeve onto the pump shaft. Slide the rotating part of the mechanical shaft seal 0433.01 onto the pump shaft. Use the assembly sleeve to do this.
4. Turn the set screw 0904.02 one or two turns into the locating ring 0516.00. Fix the set screw 0904.02 with glue. Use Loctite, type 243 to do this.
5. Position the locating ring 0516.00 exactly on the pump shaft. Secure the locating ring using the set screw 0904.02.
6. Push the spring of the mechanical shaft seal 0433.01 against the locating ring 0516.00.
7. Grease all contact surfaces between the bearing housing 0330.00 and the backplate 0161.00. Use Klüberpaste UH1 96-402 to do this.
8. Insert the O-ring 0412.02 into the cartridge seal 0491.00.
9. Push the cartridge seal 0491.00 into the backplate 0161.00 using the spring washers 0934.11 and the hexagon nuts 0920.15. Torque M8: 19 Nm.

10. Push the backplate 0161.00 into the bearing housing 0330.00. Use a plastic hammer to do this. Note the correct direction of the backplate. Grease the thread of the studs 0902.02. Use Klüberpaste UH1 96-402 to do this.
11. Fasten the backplate 0161.00 on the bearing housing 0330.00. Use the spring washers 0934.00 and hexagon nuts 0920.04 to do this. Torque: M12 - 65 Nm.
12. Slide the assembly sleeve onto the pump shaft 0211.00.
13. Slide the stationary ring of the mechanical shaft seal onto the shaft 0433.00 into the seat of the cartridge seal 0491.00. Use the assembly sleeve to do this.
14. Slide the rotating part of the mechanical shaft seal 0433.00 onto the pump shaft 0211.00. Use an assembly sleeve to do this.
15. Fasten the seal cover 0471.01 to the cartridge seal 0491.00. Use the spring washers 0934.24 and hexagon head screws 0901.29 to do this. Torque M6: 8 Nm.

For assembly of the impeller and pump housing, see section 6.5.19 on page 37.

6.5.18 Double mechanical shaft seal, back to back

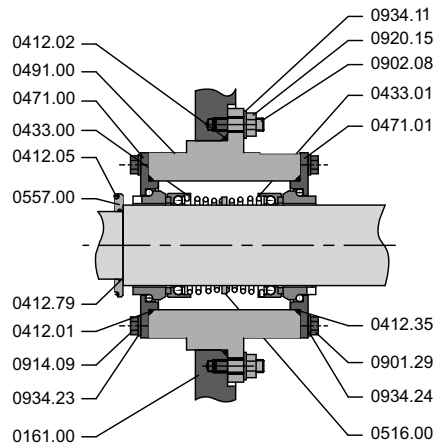

Fig. 66 Double mechanical shaft seal, back-to-back

Parts overview

- 0161.00 - backplate
- 0412.01 - O-ring
- 0412.02 - O-ring
- 0412.05 - O-ring
- 0412.35 - O-ring
- 0412.79 - O-ring
- 0433.00 - mechanical shaft seal
- 0433.01 - mechanical shaft seal
- 0471.00 - seal cover
- 0471.01 - seal cover
- 0491.00 - cartridge seal
- 0516.00 - locating ring
- 0557.00 - seal spacer
- 0901.29 - hexagon head screw
- 0902.08 - stud
- 0904.00 - set screw
- 0914.09 - hexagon socket head cap screw
- 0920.15 - hexagon nut
- 0934.11 - spring washer
- 0934.23 - spring washer
- 0934.24 - spring washer.

Characteristics

- Cartridge seal 0491.00
- seal cover 0471.00/01.

Prior to installation

- Check the shaft and the counter-ring seat for contamination and damage (sharp edges). Clean the parts or replace them as needed.
- Check all O-rings in the mechanical shaft seal to make sure they are properly situated, and correct them, if necessary.
- In order to reduce friction, moisten all of the O-ring sliding surfaces with water.

Assembly

1. Insert the stationary ring of the mechanical shaft seal 0433.01 and the O-ring 0412.35 into the seal cover 0471.01.
2. Slide the seal cover 0471.01 onto the shaft
3. Slide the assembly sleeve onto the pump shaft. Slide the rotating part of the mechanical shaft seal 0433.01 onto the pump shaft 0211.00. Use the assembly sleeve to do this.
4. Slide the locating ring 0516.00 onto the shaft.
5. Slide the rotating part of the mechanical shaft seal 0433.00 onto the pump shaft 0211.00.
6. Insert the O-ring 0412.02 into the cartridge seal 0491.00
7. Fasten the cartridge seal 0491.00 to the backplate 0161.00 using the spring washers 0934.11 and hexagon nuts 0920.15. Torque M8: 19 Nm.
8. Grease all contact surfaces between the bearing housing

0330.00 and the backplate 0161.00. Use Klüberpaste UH1 96-402 to do this.

9. Fasten the backplate 0161.00 to the bearing housing 0330.00. Use a plastic hammer to do this. Note the correct direction of the backplate 0161.00. Grease the thread of the studs 0902.02. Use Klüberpaste UH1 96-402 to do this.
10. Fasten the backplate using the spring washers 0934.00 and the hexagon nuts 0920.04. Torque M12: 65 Nm.
11. Insert the stationary ring of the mechanical shaft seal 0433.00 and the O-ring 0412.01 into the seal cover 0471.00.
12. Fasten the seal cover 0471.00 to the cartridge seal 0491.00. Use the spring washers 0934.23 and the hexagon socket head cap screws 0914.09 to do this. Torque M6: 8 Nm.
13. Fasten the seal cover 0471.01 to the cartridge seal 0491.00. Use the spring washers 0934.24 and the hexagon socket head cap screws 0914.29 to do this. Torque M6: 8 Nm

For assembly of the impeller and pump housing, see section 6.5.19 on page 37.

TM05 9018 0814

6.5.19 Assembly of the impeller and volute casing

- Slide the seal spacer 0557.00 together with the O-rings 0412.05 and 0412.79 onto the shaft 0211.00 and insert the key 0940.00.
- Grease the impeller seat and the threaded pump shaft 0211.00. Use Klüberpaste UH1 96-402 for this.



MF-581
Fig. 1 Seal spacer



MF-583
Fig. 2 Pump shaft

- Fit the impeller 0230.00.



MF-573
Fig. 3 Impeller

- Grease the Nord-Lock washer 0930.00. Use Klüberpaste UH1 96-402 for this.

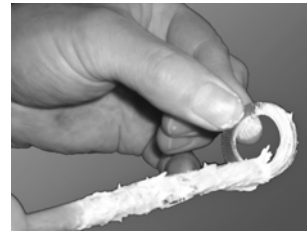

MF-619
Fig. 4 Nord-Lock washer

- Grease the Nord-Lock washer as shown as well as the complete threads of the impeller nut 0922.00.

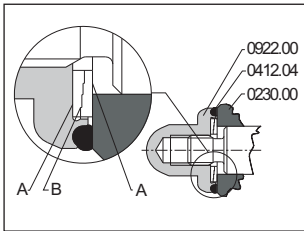

K.0225V1
Fig. 5 Schematic drawing of Nord-Lock washer

- Insert the Nord-Lock washer 0930.00 into the impeller nut 0922.00.



MF-377
Fig. 6 Nord-Lock washer in impeller nut

0230.00 - impeller

0412.04 - O-ring

0922.00 - Impeller nut

A - Fine tothing - greased

B - Thick tothing against each other - greased

- Tighten the impeller nut 0922.00 by hand. Leave about 5 mm space for the O-ring 0412.04.^A



MF-406
Fig. 7 Impeller nut

- Wet the O-ring 0412.04 with clean water and slide it over the impeller nut 0922.00 into the gap between impeller nut 0922.00 and impeller 0230.00.^A



MF-528
Fig. 8 O-ring

^A) Applies to EPDM and Viton O-rings.

In case of other O-ring materials, insert the O-ring into the impeller nut 0922.00 before the nut is screwed on.

9. Tighten the impeller nut 0922.00 to the following torques:
 M20 - 100-120 Nm
 M24 - 180-230 Nm
 M30 - 210-250 Nm.

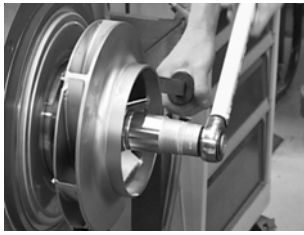

MF-575

Fig. 9 Impeller nut

10. Double mechanical shaft seal, tandem:
 Release the spring of the mechanical shaft seal's rotating ring against the impeller 0230.00.



MF-548

Fig. 10 Spring of mechanical shaft seal

11. Mount the volute casing 0102.00 and the bearing housing.
 Pay attention to the right direction of the volute casing 0102.00.



MF-524

Fig. 11 Volute casing and bearing housing

12. Grease the studs 0902.02 of the volute casing 0102.00.
 Use Klüberpaste UH1 96-402 for this.



MF-523

Fig. 12 Studs of volute casing

13. Assemble the volute casing 0102.00 and the bearing housing 0330.00 by using the spring washer 0934.00 and the hexagon nuts 0920.04.

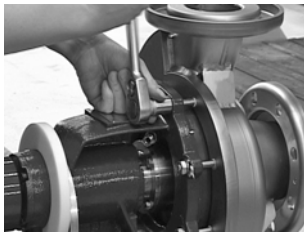

MF-526

Fig. 13 Volute casing and bearing housing

14. Tighten the hexagon nuts 0920.04 in the order shown below.
 Torques:
 M10 - 37 Nm
 M12 - 65 Nm.

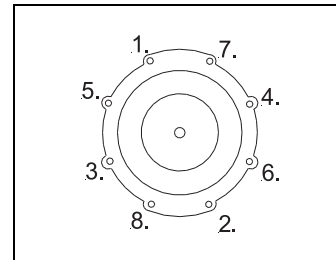

K.0356V1

Fig. 14 Tightening order

6.6 Troubleshooting

Problem	Cause	Remedy
Pump does not deliver or delivers at a reduced rate.	1. Incorrect electrical connection (two phases).	1. Check the electrical connections and correct, if necessary.
	2. Wrong direction of rotation.	2. Reverse the phases of the power supply (reverse the polarity).
	3. Air in suction line or in pump. ¹	3. Vent the suction line or the pump and refill.
	4. Back pressure too high.	4. Reset the operating point according to the data sheet. Check the system for contamination.
	5. Suction head too high, NPSH feed too low.	5. Raise the liquid level on the suction side. Open the isolating valve in the suction line completely.
	6. Lines clogged or foreign material in the impeller.	6. Open the pump and fix the problem.
	7. Air inclusion as a result of a defective seal.	7. Check the pipeline seals, the pump housing seals and the shaft seals. Replace, if necessary
	8. Disturbed inflow condition due to tees, valves, bends or container outlet.	8. Check positioning and design of the parts and correct, if necessary.

Problem	Cause	Remedy
Motor safety switch turns motor off. Motor is overloaded.	1. Pump seized up because of clogging.	1. Open the pump and fix the problem.
	2. Pump seized up because pump body was twisted by the pipelines. Check for damage.	2. Install the pump so that there is no stress on it. Support the pipelines at fixed points.
	3. Pump continues to run beyond rated operating point.	3. Set the operating point according to the data sheet.
	4. Density or viscosity of pumped medium is higher than the value stated in the order.	4. If it is acceptable that the performance is lower than the value stated, decrease the flow rate on the pressure side. Otherwise, use a more powerful motor.
	5. Motor safety switch not properly adjusted.	5. Check the setting. Replace the safety switch if necessary.
	6. Motor running on two phases.	6. Check the electrical connections. Replace defective fuses.
Pump produces too much noise. Pump runs roughly and vibrates.	1. Suction head too high, NPSH feed too low.	1. Raise the liquid level on the suction side. Open the isolating valve in the suction line completely.
	2. Air in suction line or in pump. ¹	2. Vent the suction line or the pump and refill.
	3. Back pressure lower than stated.	3. Set the operating point according to the data sheet.
	4. Impeller out of balance.	4. Clean, inspect, and rebalance the impeller.
	5. Internal parts worn.	5. Replace the parts.
	6. Pump is twisted (causing contact noises). Check for damage.	6. Install the pump so that there is no stress on it. Support the pipelines at fixed points.
	7. Bearings defective.	7. Replace the bearings.
	8. Insufficient, excessive or incorrect lubricant in bearings.	8. Adjust the amount of lubricant or use a different type of lubricant.
	9. Motor cooling fan is defective.	9. Replace the motor cooling fan.
	10. Gear ring of coupling (power transmission) is defective. ²	10. Replace the gear ring of the coupling. Realign the coupling.
	11. Foreign material in pump.	11. Open the pump and clean it (install a screen in front of self-priming pumps, if necessary).
	12. Pipe fastening or installation stands are too unstable.	12. Check pipe fastening and installation stands and reinforce.
Leakage at pump housing, at connections, at mechanical seal, at stuffing box or at gland seal.	1. Pump is twisted (causing leaks at the pump housing or connections).	1. Install the pump so that there is no stress on it. Support the pipelines at fixed points.
	2. Housing seals and seals of the connections defective.	2. Replace the housing seals or the seals of the connections.
	3. Rotating mechanical seal dirty or stuck.	3. Inspect and clean the rotating mechanical seal.
	4. Rotating mechanical seal worn.	4. Replace the mechanical seal.
	5. Stuffing box packing rings worn out.	5. Tighten the stuffing box, add more packing rings, or replace the packing rings.
	6. Shaft surface or shaft safety sleeve worn down.	6. Replace the shaft or the shaft safety sleeve. Repack the stuffing box.
	7. Elastomer unsuitable for the pumped liquid.	7. Use an elastomer suitable for the pumped medium and the temperature.
Impermissible temperature increase at the pump, bearing housing or motor.	1. Air in suction line or in pump. ¹	1. Vent the suction line or the pump and refill.
	2. Insufficient, excessive or incorrect lubricant in bearings.	2. Adjust the amount of lubricant or use a different type of lubricant.
	3. Pump and bearing housing are twisted.	3. Install the pump so that there is no stress on it. Support the pipelines at fixed points. Check the alignment of the coupling.
	4. Axial thrust too high. ¹	4. Inspect the relief holes in the impeller and the split rings at the inlet.
	5. Motor safety switch is defective or not properly adjusted.	5. Check the adjustment. Replace the motor safety switch if necessary.
	6. Valve on pressure side closed.	6. Open the valve on the pressure side.

1. Does not apply to self-priming pumps.
2. Applies to CN base plate design.

6.7 Disposal

This product or parts of it must be disposed of in an environmentally sound way:

1. Use the public or private waste collection service.
2. If this is not possible, contact the nearest GEA Hilge company or service workshop.

6.8 HILGE assembly tool kit

Remove and install the mechanical seals safely and reliably using tools from the HILGE assembly tool kit.

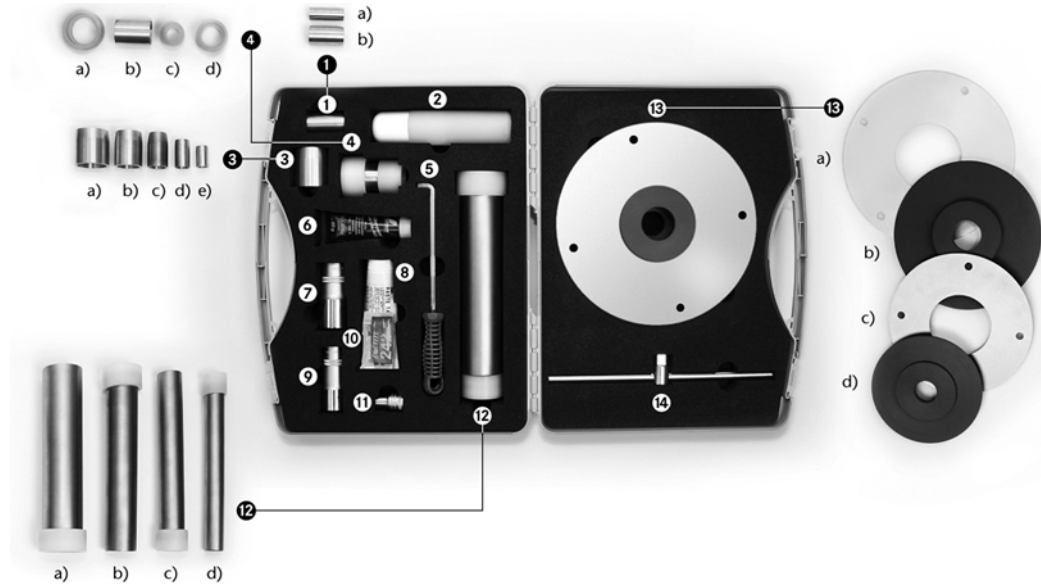

Fig. 15 HILGE assembly tool kit

6.8.1 Content and use

Pos. (fig.)	Description - shaft diameter				
		65-160 / 65-200	80-160	65-250 80-200 / 80-250 / 80-315 100-200 / 100-250 / 100-315 125-250	125-315 150-250 / 150-315 / 150-400 200-400
2	Spray bottle	•	•	•	•
3a	Assembly sleeve Ø50				•
3b	Assembly sleeve Ø40			•	
3c	Assembly sleeve Ø30	•	•		
4a	Plastic adapter Ø40			•	
4d	Plastic adapter Ø30	•	•		
5	Ejector for mechanical seal - stationary ring	•	•	•	•
6	Klüberpaste UH1 96-402	•	•	•	•
7	Socket spanner SW 27	•	•		
7	Socket spanner SW 32			•	
7	Socket spanner SW 50				•
7	Plastic insert for socket spanner SW 27	•	•		
8	Optimol Paste TA	•	•	•	•
10	Screw locking, Loctite Type 243	•	•	•	•
12a	Mechanical seal assembly sleeve with plastic adapter Ø50				•
12b	Mechanical seal assembly sleeve with plastic adapter Ø38 and Ø40			•	
12c	Mechanical seal assembly sleeve with plastic adapter Ø28 and Ø30	•	•		
14	1/2" square T-bar	•	•	•	•

TM05 6455 5112

7. Certificate of non-objection

Overview

This section contains a certificate of non-objection. In the event of inspection or repair send the pump including this certificate to HILGE.

Certificate of non-objection

The following pump and its accessories, together with this certificate of non-objection, are herewith contracted out by the undersigned for inspection/repair:

Pump data

- Model:
- No.:
- Delivery date:
Reason for inspection / repair contract

The pump (please mark with a cross)
___ was not used in liquids hazardous to health
___ was used for the following:

Please state the last liquid pumped, if known:

The pump was carefully drained and also cleaned inside and out before it was shipped/made available. (please mark with a cross).

___ No special safety measures are required in the course of further handling.
___ The following safety measures pertaining to flushing liquids, residual liquids, and disposal are required:

We confirm that the information given above is correct and complete and that shipment is in compliance with legal regulations.

Company (address): _____
Telephone: _____
Fax: _____
Email: _____
Name (incl. title)
(please print): _____
Date: _____
Company stamp /
signature: _____



GEA Hilge

Niederlassung der GEA Tuchenhagen GmbH

Hilgestraße 37-47
55294 Bodenheim, Germany
Phone: +49 6135 7016-0
Fax: +49 6135 1737
gea.com