

GEA SMARTPUMP

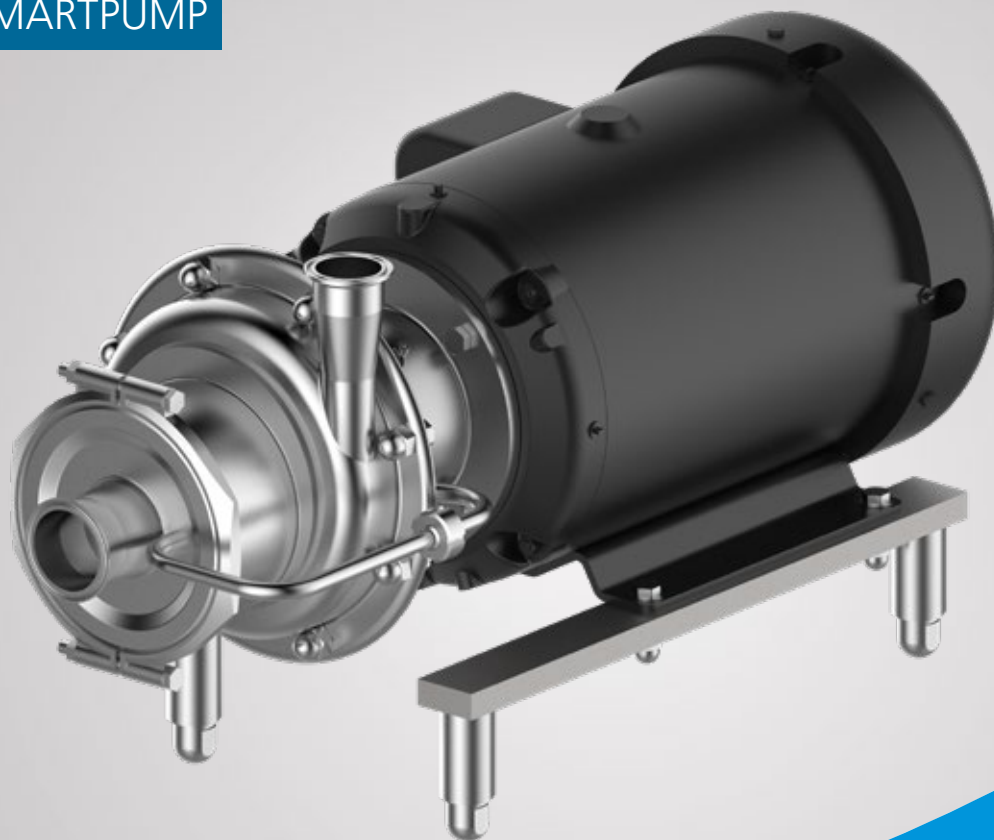

GEA Hilge TPS

Single-stage Self-priming Centrifugal Pumps
Catalog

Legal notice

Publication date: February 2022

The publication of specifications, technical data and information in written or electronic form does not release the user from the responsibility of checking for themselves all products delivered by us for suitability for the application(s) intended. These may be subject to change without prior notification. Errors and printing errors excepted – we assume no liability for the correctness of specifications given.

The general terms and conditions of delivery apply.

All rights reserved – copyright on all contents.

GEA reserves the right to make technical changes to the information in this catalog.

GEA Hilge

Niederlassung der GEA Tuchenhagen GmbH

Hilgestraße 37–47, 55294 Bodenheim, Germany

Registered Office: Büchen, Court of Registration: HRB 836 SB in Lübeck

Management Board: Tobias Dieckmann, Michael Wulle, Oliver Hegehofer

VAT-ID: DE 812589019, Tax No.: 105/5857/1004

Flow Components	
Introduction	6
Hygienic Pumps	
Introduction	7
Certificates	18
GEA Hilge TPS Pumps	
Overview	20
Product Range	25
Connection Guide	26
Seals	29
Installation	30
Media Guide	32
Pump Selection Matrix	42
2-pole, 50 HZ	
Pump Selection Matrix	44
GEA Hilge TPS 2030	46
GEA Hilge TPS 3050	48
GEA Hilge TPS 8050	50
GEA Hilge TPS 8080	52
2-pole, 60 HZ	
Pump Selection Matrix	54
GEA Hilge TPS 2030	56
GEA Hilge TPS 3050	58
GEA Hilge TPS 8050	60
GEA Hilge TPS 8080	62
Appendix	
Composition of Order Code	64
Inquiry Sheet	68
Description of Certificates and Test Reports	70
Abbreviations and Terms	72



GEA Flow Components
Keeping your product in motion

Regardless of the application – for our customers product quality and profitability are what matters. This is what GEA Flow Components is known for. Our engineers are specialists in everything that flows.

GEA Group

GEA is one of the largest technology suppliers for food processing and a wide range of other industries. The global group specializes in machinery, plants, as well as process technology and components. GEA provides sustainable solutions for sophisticated production processes in diverse end-user markets and offers a comprehensive service portfolio.

GEA Flow Components

In addition to our hygienic pump portfolio, our range of sophisticated process components also includes hygienic and aseptic valves as well as cleaning technology.

All components and services are available worldwide through the international GEA sales network.



Around one quarter of the milk processed is handled by GEA equipment



Roughly every second liter of beer is brewed using GEA equipment and solutions



Every fourth liter of human blood is handled by GEA equipment



Approx. one in three instant coffee lines has been built by GEA

GEA Hilge Hygienic Pumps – The heart of every process

GEA Hilge offers a versatile range of centrifugal and positive displacement pumps for a wide variety of sensitive applications in the beverage, food and pharmaceutical industries.

Our pumps with their sophisticated design ensure particularly gentle conveyance of the respective medium, offer lasting reliability and are characterized by economic efficiency. After all, hygienic pumps are used in processes that directly affect the product and production. They are the heart of every process.

State-of-the-art pump technology, made to our customers' preferences

At the GEA Hilge Hygienic Pumps Center of Competence in Bodenheim we develop innovative pumps and processes together with our customers. Our decades of up-close experience with operations and systems at our customers' production sites ensure optimum selection and configuration of the right pumps for every application (e.g. food and dairy, brewery and beverage, pharmaceutical and biotech, personal and home care).

Maximum efficiency

Two product lines, GEA VARIPUMP and GEA SMARTPUMP, enable our customers to choose from a highly versatile pump range with a multitude of smart adaption options to achieve simpler operation, higher-quality production, and reduced consumption of valuable resources. Special construction features of our many types of pumps provide for exceptionally gentle product handling, delivering top-quality products to consumers.

Maximum reliability

Our customers rely on the safe, continuous operation of their production processes without unplanned breaks or disturbances. That is why GEA pumps are optimized for uncompromising reliability in all applications. Thanks to their robust design and long service life, they are known as "workhorses" for their ease of maintenance and outstanding service, proven over decades, and for the great number of pumps currently in operation. Of course, GEA pumps also comply with all relevant hygiene standards and norms with continuous documentation and up-to-date certifications safely ensuring judicial security.



Two modern pump lines for maximum efficiency

Two product lines, GEA VARIPUMP and GEA SMARTPUMP, form a highly versatile pump range with a multitude of adaption options to ensure simpler operation, higher-quality production, and reduced consumption of valuable resources.

Selecting and configuring the right pump requires a high level of experience. The selection matrix provides initial guidance.

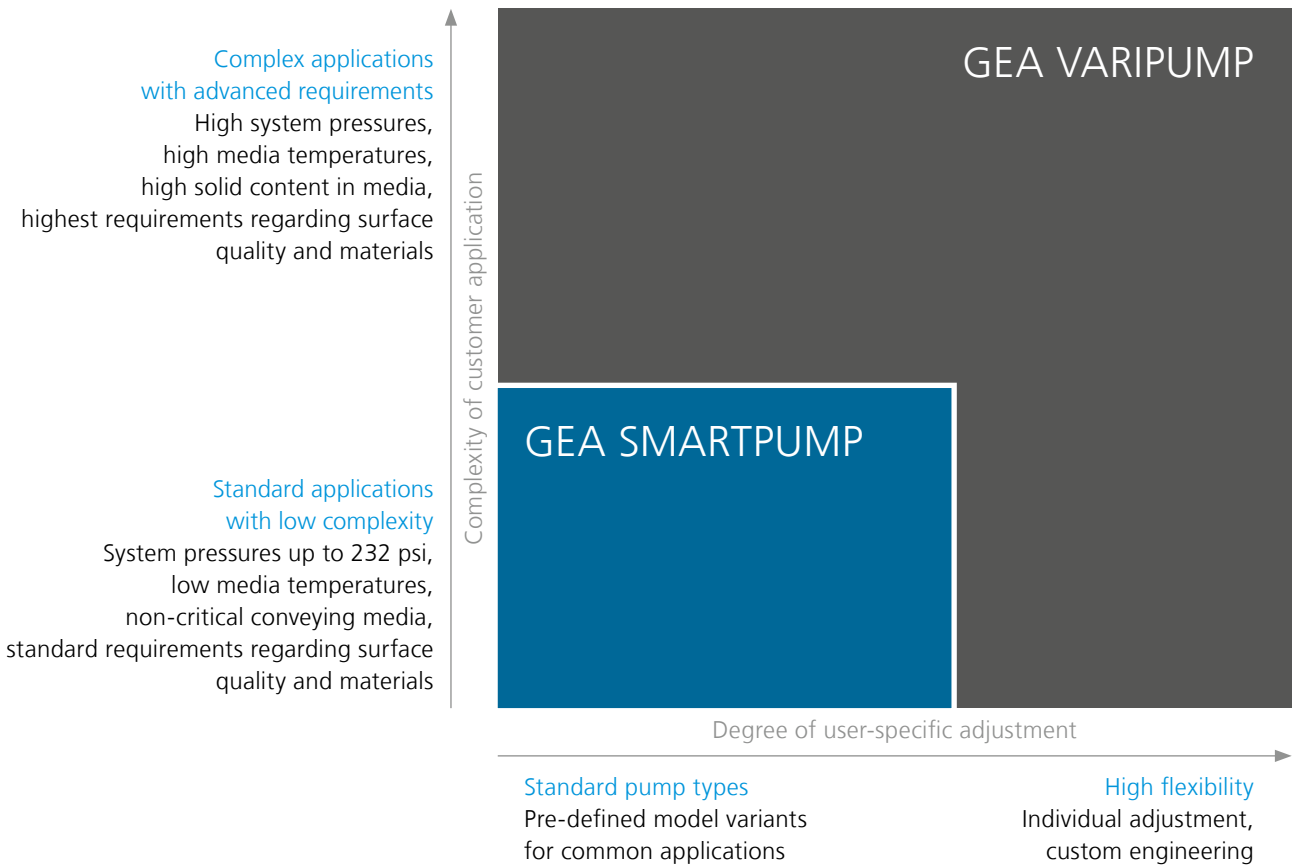

GEA VARIPUMP

The pump series in the GEA VARIPUMP line have been conceived for extreme application demands. The pumps are individually optimized by GEA for each task.

GEA VARIPUMP models are made entirely without die-cast components, offering high-quality surfaces and materials that meet stringent demands even in the sensitive pharmaceutical industry, further ensured by complementing services, e.g. Witnessed Factory Acceptance Test (FAT).

With a great variety of set-up and customizing options the pumps can be adapted individually to any production process, for lower operational costs and maximum system efficiency.

- Developed for advanced application conditions
- Project-specific customization
- Surface roughness up to $R_a \leq 16 \mu\text{in}$ ($0.4 \mu\text{m}$)
- Product-wetted materials according to specific requirements (e.g. no cast parts, $F_e \leq 1\%$ optional)

GEA SMARTPUMP

The GEA SMARTPUMP line comprises highly standardized and attractively priced pump series for common, often-used applications at standard conditions. The pumps are easy to select and ready for fast delivery. Within pre-defined parameters, the standard models can be configured to individual tasks.

The modular construction using high-value materials, the proven “Hygienic Design” and easy-to-apply standardized spare parts all recommend GEA SMARTPUMP pumps for use in cost-critical production systems – at no compromise in terms of quality.

- Application for common and clearly defined “standard” process tasks
- Simple selection and configuration
- Fast delivery
- Standardized spare parts

Self-priming Pumps 50 Hz

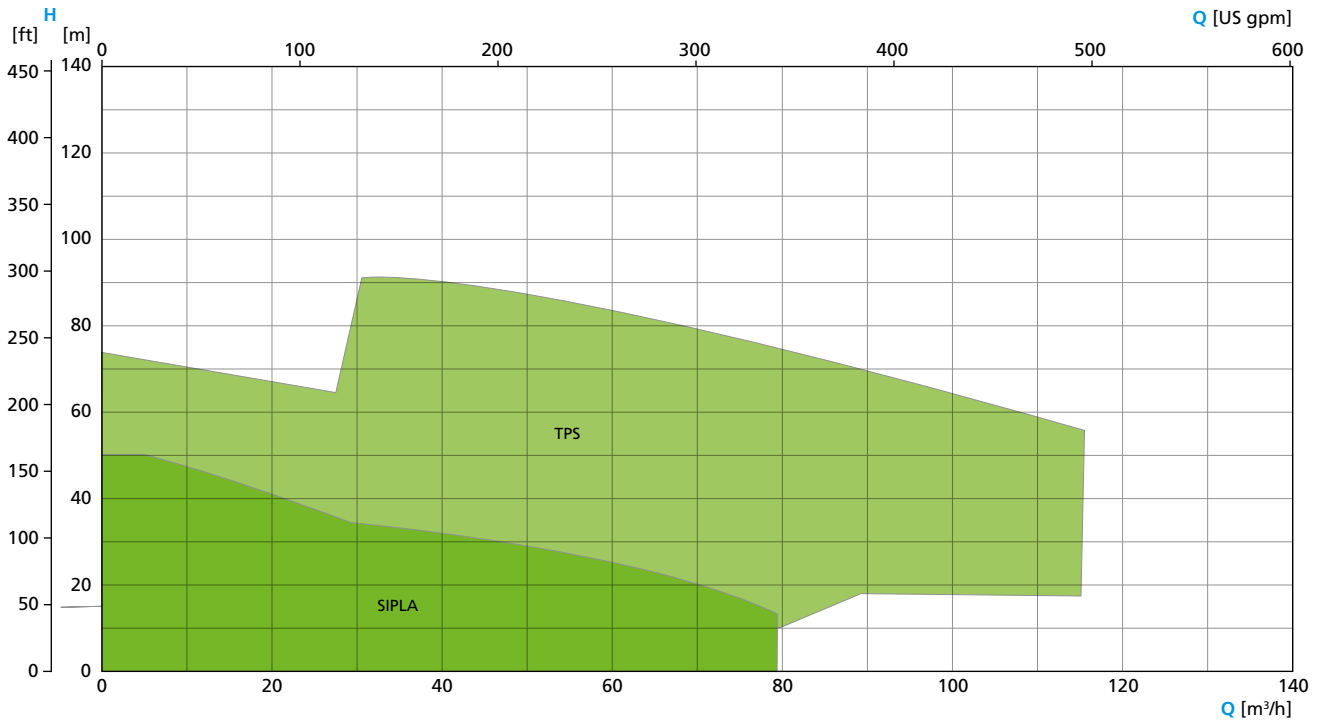

Self-priming Pumps 60 Hz

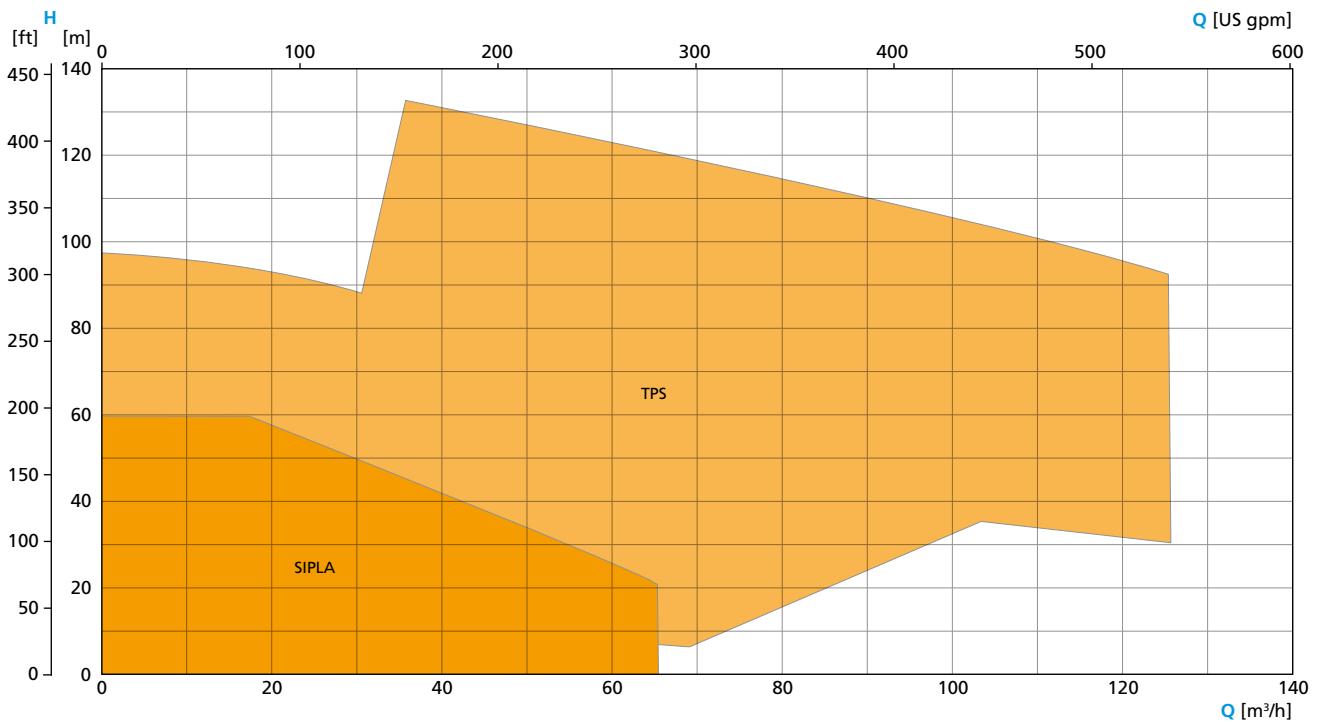

Centrifugal Pumps
2-pole, 50 Hz

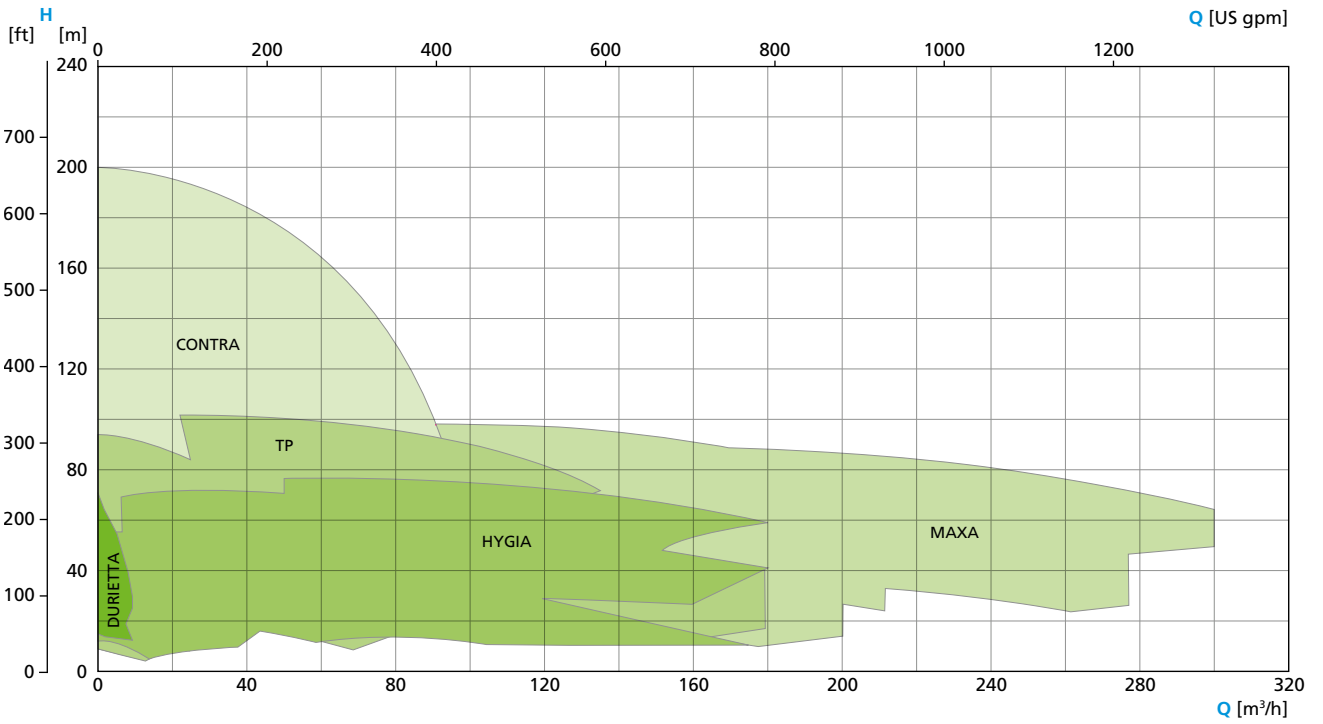

Centrifugal Pumps
2-pole, 60 Hz

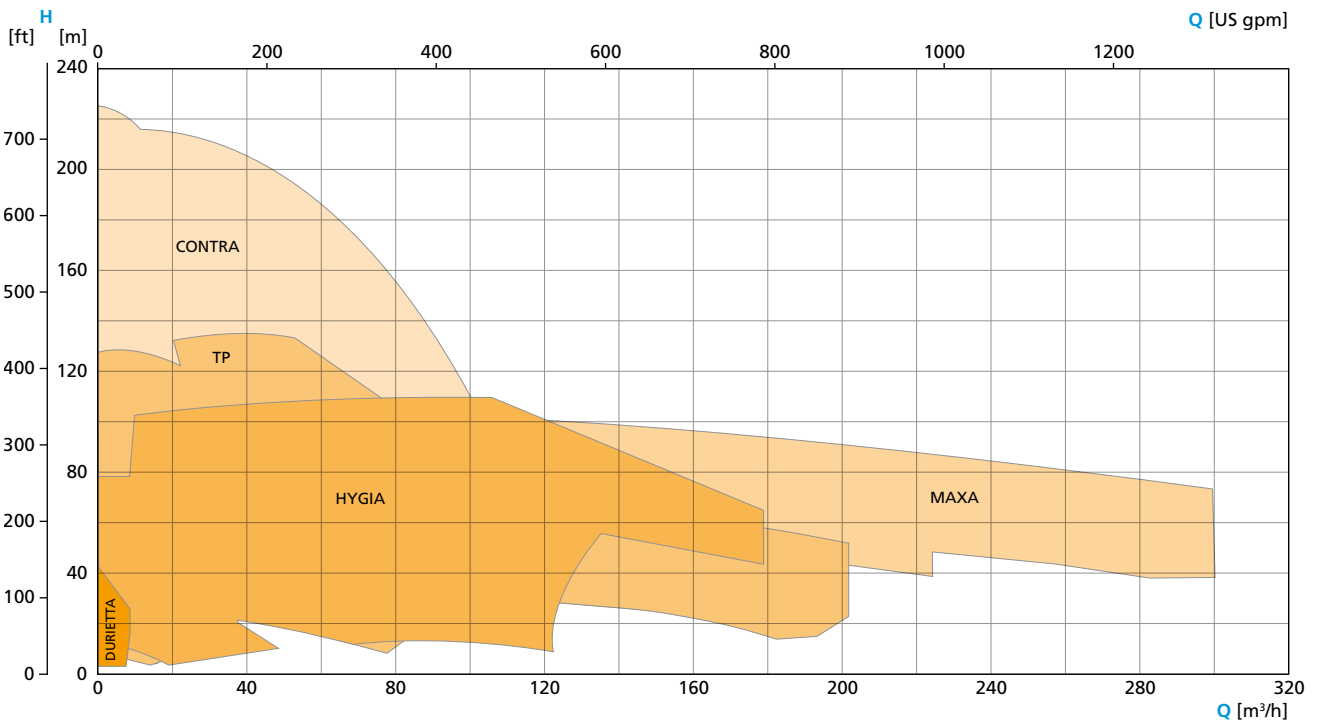

Centrifugal Pumps
4-/6-pole, 50 Hz

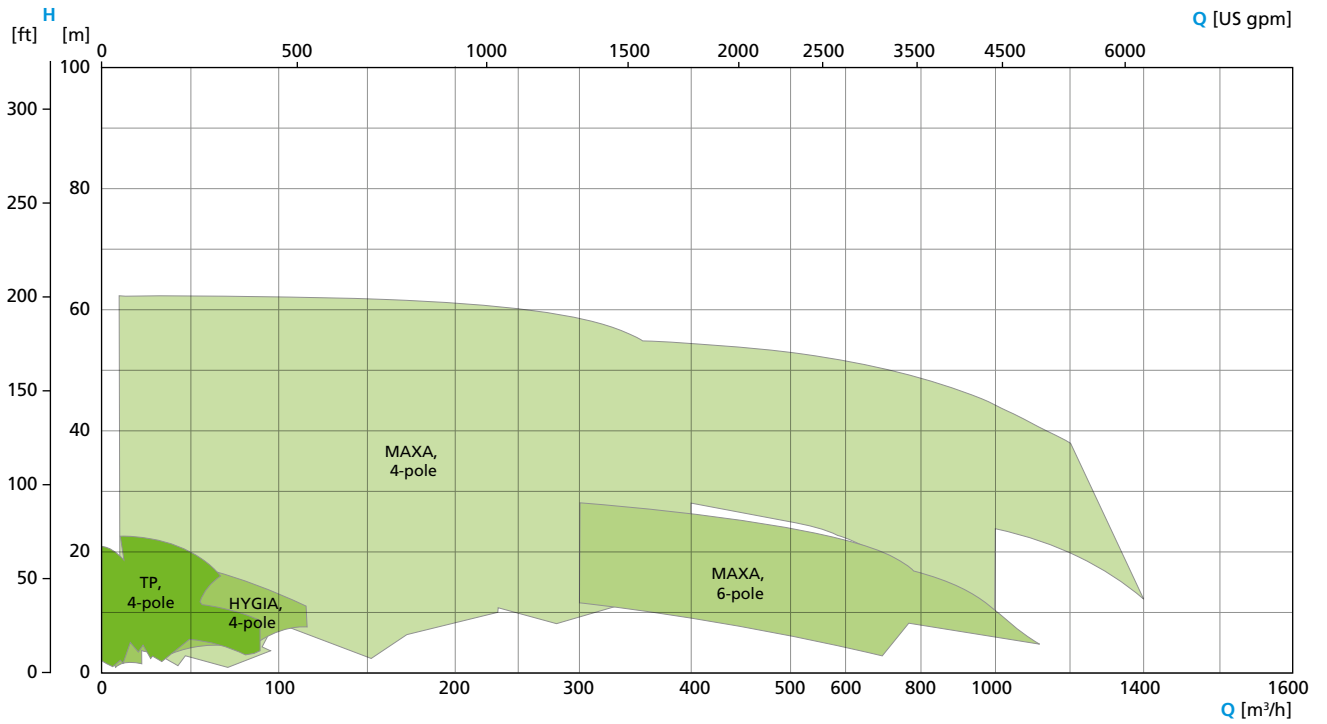

Centrifugal Pumps
4-/6-pole, 60 Hz

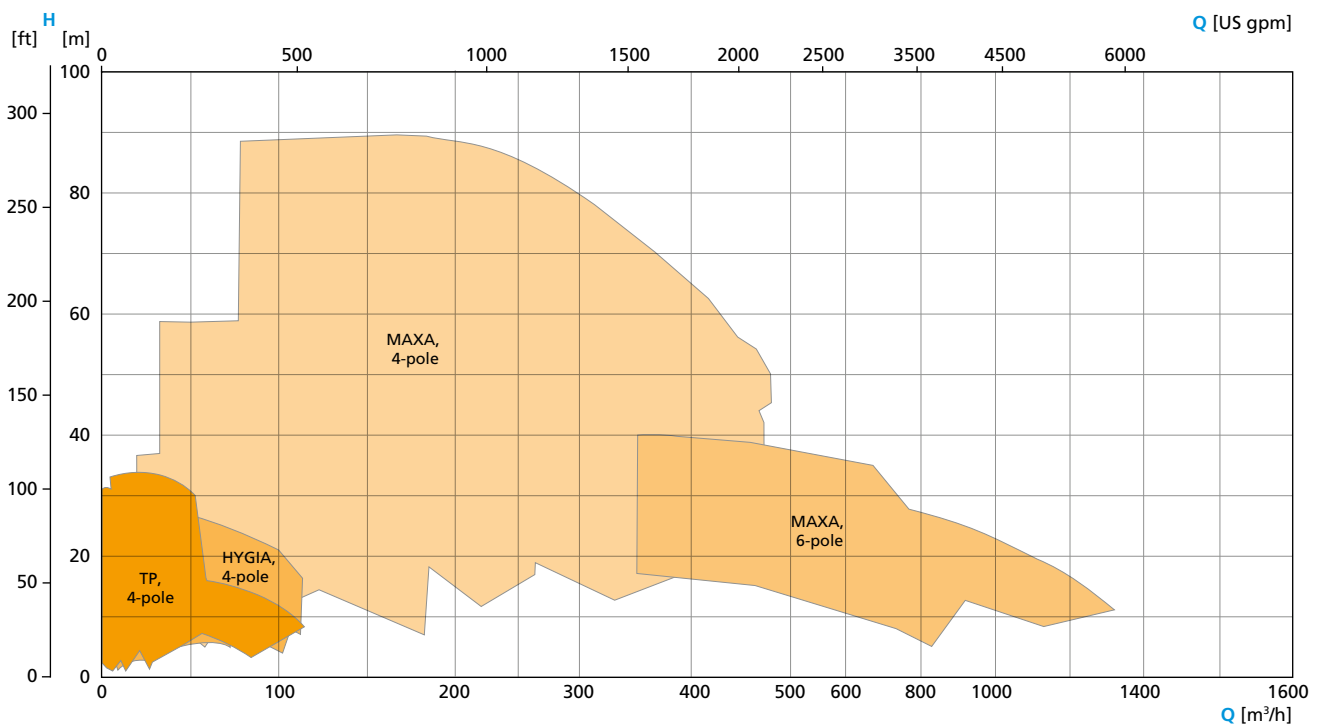

High-pressure Pumps 50 Hz

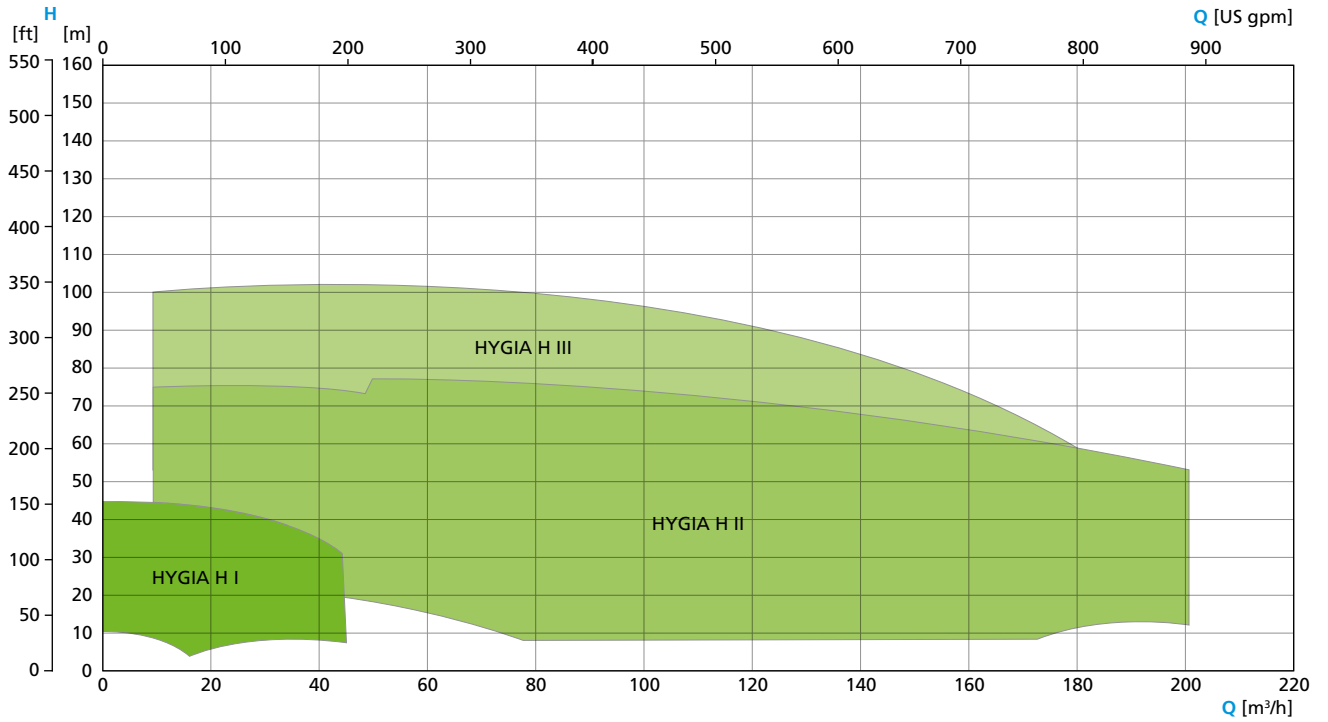

High-pressure Pumps 60 Hz

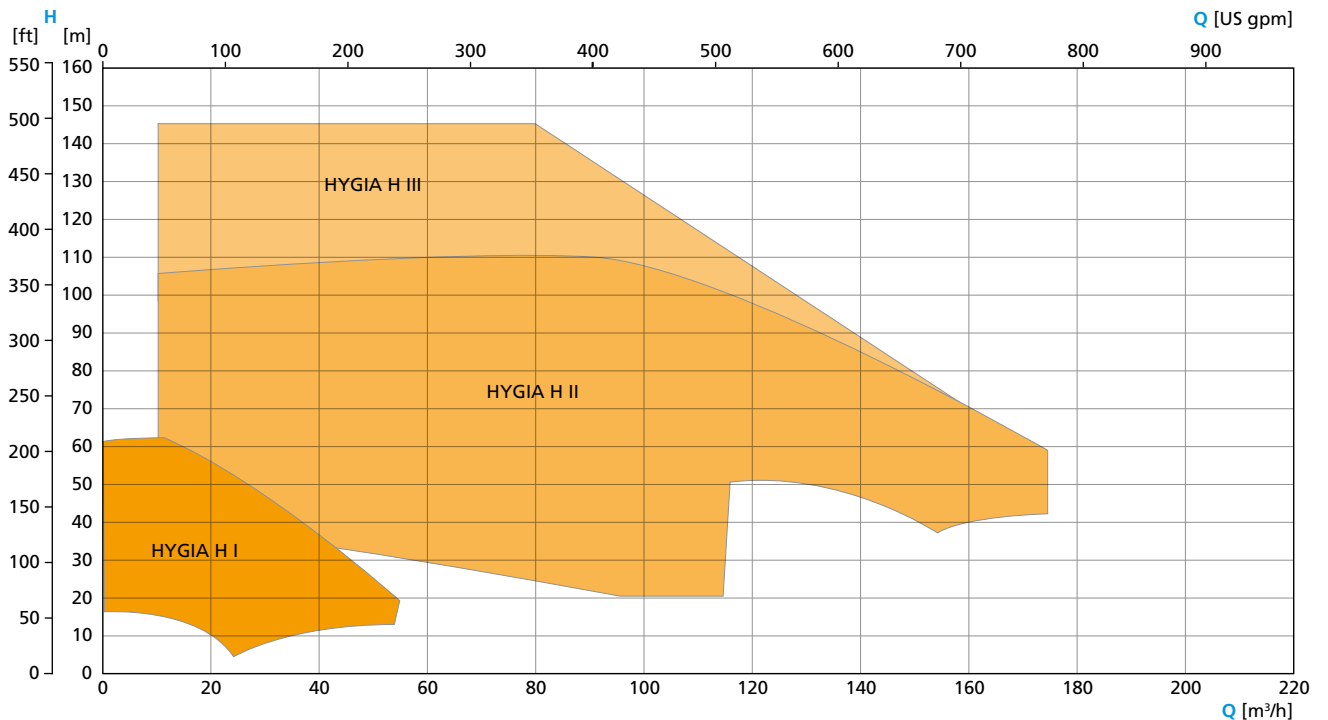

Rotary Lobe Pumps

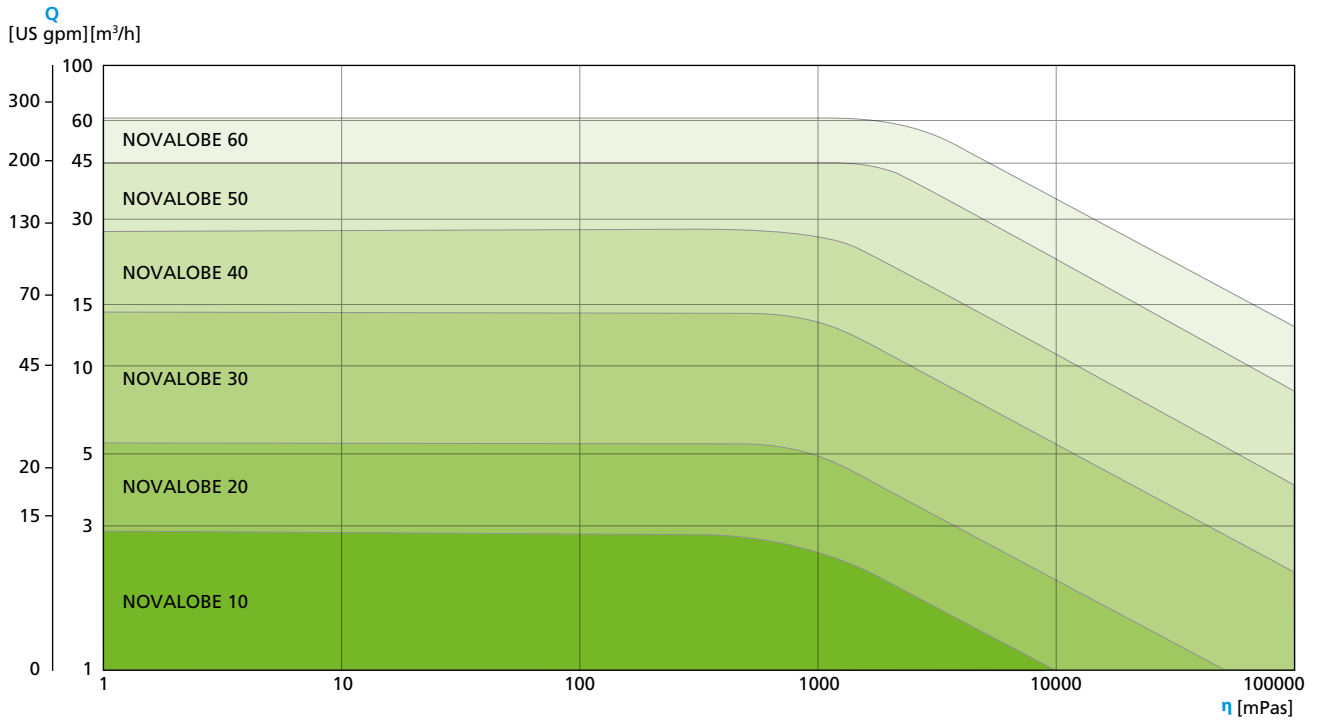

Twin Screw Pumps

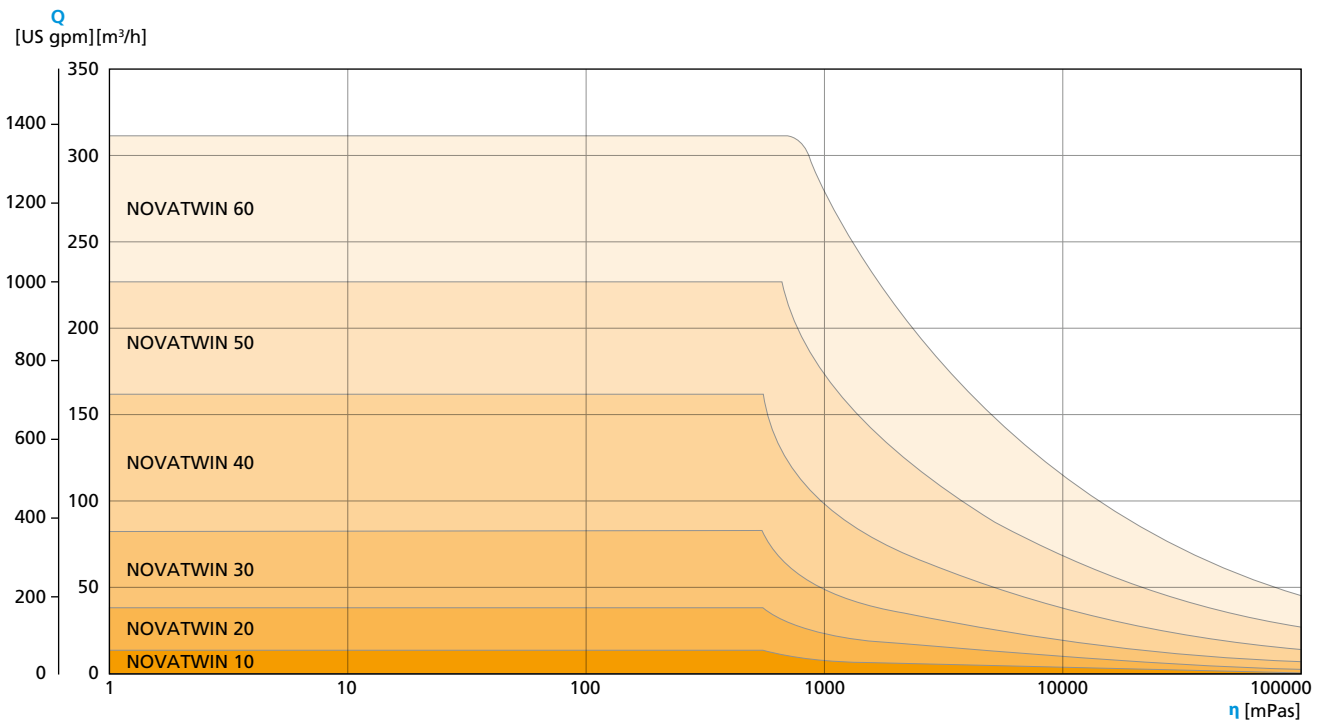

GEA VARIPUMP

Wide model range with numerous variants. Customization to specific customer requirements

GEA SMARTPUMP

Clearly defined list of models, limited to standard requirements no other variants

GEA Hilge HYGIA/HYGIA H

The “Swiss Knife” among the hygienic pumps. Premium quality and highest flexibility of customization ensure successful application in the food, beverage, and pharma industries.

Technical data	50 Hz	60 Hz
Max. flow rate	880 US gpm	770 US gpm
Max. head	328 ft	476 ft
System pressure	232/363/928 psi	



Single-stage end-suction centrifugal pumps

GEA Hilge MAXA

A single-stage centrifugal pump designed for heavy-duty operation in industrial processes. The major dimensions and characteristics of these pumps correspond to DIN EN 733 and DIN EN 22858.

Technical data	50 Hz	60 Hz
Max. flow rate	6,380 US gpm	5,808 US gpm
Max. head	328 ft	328 ft
System pressure	145 psi	



GEA Hilge SIPLA

A single-stage self-priming side channel pump, especially suited for SIP/CIP return systems and applications with high gas content. Right- and left-hand rotation can be freely adjusted for additional application options.

Technical data	50 Hz	60 Hz
Max. flow rate	343 US gpm	282 US gpm
Max. head	154 ft	197 ft
System pressure	145 psi	

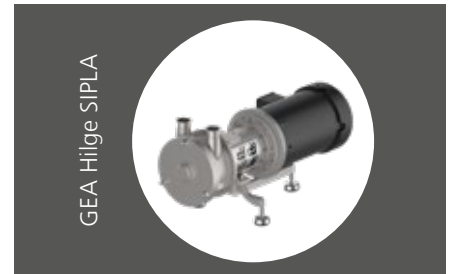

Single-stage self-priming centrifugal pumps



GEA Hilge TP

The GEA Hilge TP is the smart solution for standard applications. The single-stage centrifugal pump suits a wide range of applications and offers uncompromising hygiene and quality.

Technical data	50 Hz	60 Hz
Max. flow rate	748 US gpm	902 US gpm
Max. head	295 ft	443 ft
System pressure	232 psi	

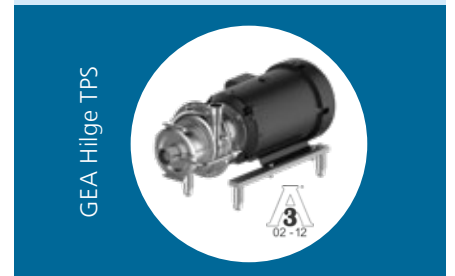

GEA Hilge TPS

This self-priming centrifugal pump is the solution of choice especially for emptying tanks as well as for conveying products containing gas, e.g. CIP return systems.

Technical data	50 Hz	60 Hz
Max. flow rate	506 US gpm	550 US gpm
Max. head	312 ft	453 ft
System pressure	232 psi	

GEA Hilge CONTRA

Single- and multi-stage centrifugal pumps are available in this series. The hygienic design in every detail provides perfect solutions to numerous tasks in sterile and hygienic processes.

Technical data	50 Hz	60 Hz
Max. flow rate	440 US gpm	440 US gpm
Max. head	656 ft	754 ft
System pressure	363 psi	

GEA Hilge NOVALOBE

This rotary lobe pump has been specifically designed for highly viscous media – and for applications where gentle pumping is required. The pump is fully drainable with vertical ports.

Technical data	50/60 Hz
Max. displacement	0.55 gallons/rev
Max. differential pressure	232 psi
System pressure	145/232 psi

GEA Hilge NOVATWIN

The GEA Hilge NOVATWIN is a flexible twin screw pump. It fulfills the highest hygienic standards for gentle product handling as well as CIP with one pump only.

Technical data	50/60 Hz
Max. flow rate	440 US gpm
Max. differential pressure	363 psi
System pressure	up to 435 psi



Multi-stage centrifugal pumps

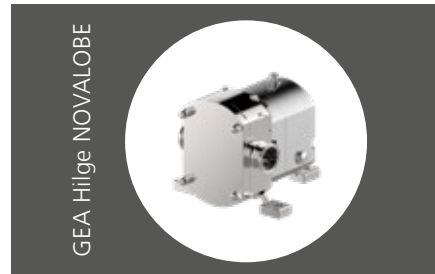

Rotary-lobe pumps
Positive displacement pumps



Twin-screw pumps



GEA Hilge DURIETTA

This end-suction single- or multi-stage centrifugal pump in a very compact design has been created for applications with low flow rates at high flow heads.

Technical data	50 Hz	60 Hz
Max. flow rate	35 US gpm	35 US gpm
Max. head	236 ft	135 ft
System pressure	116 psi	

The certificates listed here are valid for corresponding GEA pump models. Pumps conforming to the requirements of the European Hygienic Engineering and Design Group (EHEDG) as well as 3-A Sanitary Standards, Inc. (3-A SSI) are available for numerous fields of application.

Moreover, independent, standardized tests have confirmed the efficient, problem-free cleaning ability of numerous pumps – for optimum safety and economic gain.

EHEDG certificates apply only to the specific pump type as listed. However, they may be transferred to specific other pump types, owing to identical housing designs and flow path geometries.

Document	GEA Hilge HYGIA/ HYGIA H	GEA Hilge TP/TPS	GEA Hilge CONTRA	GEA Hilge MAXA	GEA Hilge DURIETTA	GEA Hilge SIPLA	GEA Hilge NOVALOBE	GEA Hilge NOVATWIN
3-A Sanitary Standard	•••	•						•
EHEDG certificate	•*	•*	•*				•*	•*
FDA declaration of conformity	•	•	•	•	•	•	•	•
Declaration of compliance with the order 2.1 acc. to EN 10204	•		•	•	•	•	•	•
Test report 2.2 acc. to EN 10204	•	•	•	•	•	•	•	•
Inspection certificate 3.1 acc. to EN 10204	•	•	•	•	•	•	•	•
EAC-Certificate	•*	•	•	•	•	•	•	•
Surface roughness test report	•	•	•	•			•	•
Delta ferrite test report	•		•				•	•
Acoustic measurement test report	•	•	•	•	•	•	•	•
USP Class VI – declaration of conformity	•	•	•			•	•	•
Certificate in acc. with the regulation (EG) No. 1935/2004	•	•	•	•	•	•	•	•
Certificate DIN EN ISO 9001:2015	•	•	•	•	•	•	•	•

Many more certificates on request

Subject to change without notice.

* registered for certification/recertification

** HYGIA H III registered for certification

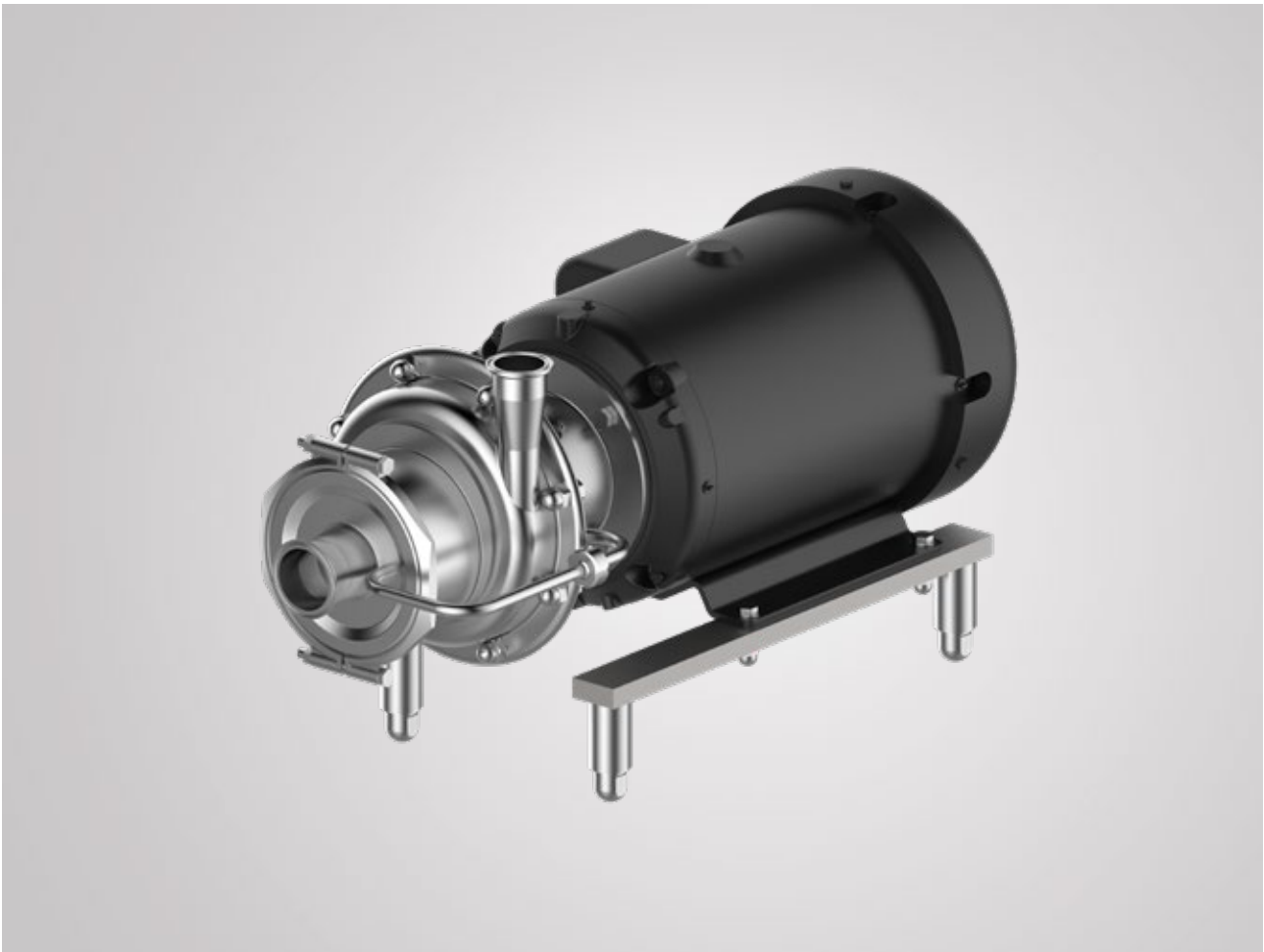

GEA Hilge TPS on 3-A stainless steel adjustable feet

Features and benefits

- 2 in 1: self-priming pump for CIP process and product transfer lead to lower investment cost
- Good efficiency and duty point precise sizing through finely graduated impeller diameters or operation at the frequency converter
- Covers large capacity range: suitable for large plants and long pipelines
- Process safety and optimal cleanability through Hygienic Design
- Smooth rotation results in quiet operation compared to side channel pumps
- Modular design system allows adaptation to changed requirements (e.g. to other impeller sizes or other mechanical seal)
- Low spare parts inventory due to modular pump (same sealing concept as TP)

GEA Hilge TPS

By combining the existing TP series with an upstream screw rotor stage a new generation of hygienic self-priming centrifugal pumps has been created. The GEA Hilge Centrifugal Pump TPS is a self-priming pump for viscosities of up to 500 mPas. The pump is used for CIP return applications, for emptying tanks as well as for conveying products containing gas. The TPS is characterized by a low sound power level, highest efficiency and excellent cleaning properties. The TPS series also permits evacuation of pipes on the suction side – so that just one pump is required for CIP return and product conveying!

Technical Data

	50 Hz	60 Hz
Flow rate	506 US gpm	550 US gpm
Head	312 ft	453 ft
Operating pressure	232 psi	232 psi
Operating temperature	203 °F	203 °F
Sterilization temperature	284 °F (SIP)	284 °F (SIP)
Max. pump efficiency	71 %	72 %

Applications

The GEA Hilge TPS pump range is suitable for the following application areas and products, due to the hygienic design and material selection:

Breweries

- Beer, wort, yeast, water, CIP solutions

Dairies

- Milk, cream, yoghurt, whey, brine, CIP solutions

Food

- Oils, sauces, stock, brine, flavours, ice-cream mix, CIP solutions

Fields of applications

- CIP solutions, tank emptying, gas conveying

Design

GEA Hilge TPS pumps are single-stage, self-priming, centrifugal pumps, designed to meet the hygienic requirements of sterile process technology.

The pumps are available in eleven sizes with a variety of flexible versions. The pumps are CIP- and SIP-capable in compliance with the DIN EN 12462 performance criteria. The design fulfills the following requirements:

- 3-A Sanitary Standard
- EHEDG (registered for recertification)
- EAC
- GMP regulations



Certification

Pump connections

GEA Hilge offers the following standard connections for the GEA Hilge TPS pump range:

- Tri clamp

Additional connections such as sterile connections in accordance with DIN 11853, SMS, RJT, DIN or ISO clamp connections are available on request.

Selected connections also available with drain port. You can find additional information in the connection selection guide from page 26 to 28.

ATEX

For use in potentially explosive areas, Adapta pumps are available. These pumps, which possess an EC declaration of conformity in accordance with the ATEX guideline 2014/34/EU, correspond to device categories 2 or 3, and can be used in zone 1 or 2.



ATEX-Symbol

For explanation see chapter certificates on page 18.

Open impeller design

- All parts stainless steel, wetted components made of 1.4404 or 1.4409 (AISI 316L)
- Surface roughnesses of $R_a \leq 32 \mu\text{in}$ can be achieved by mechanical treatment of the surface

Semi-open impeller



The electro-polished, stainless steel, semi-open impeller is available in two versions, according to the application.

Impeller version	Surface finish
Cast	$R_a \leq 125 \mu\text{in}$ (3.2 μm)
Milled	$R_a \leq 32 \mu\text{in}$ (0.8 μm)

The impeller is suitable for low-viscosity liquids and liquids containing low content of particles.

Materials

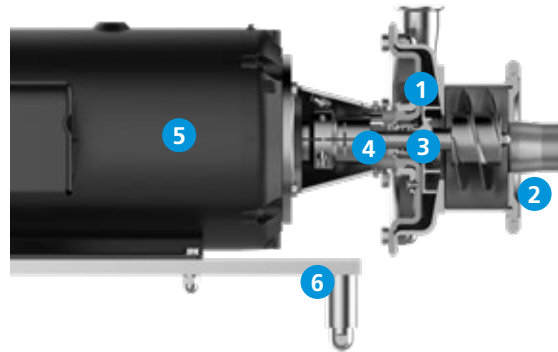

Material overview GEA Hilge TPS

Item	Component	Material	No.
1	Impeller	CrNiMo steel	316L (1.4404/1.4435)
2	Pump casing	CrNiMo steel	316L (1.4404/1.4435)
3	Seal	Single mechanical seal carbon/stainless steel or SiC/SiC other versions available on request	
4	Pump shaft without key	CrNiMo steel	316Ti (1.4571)
5	Motor	Rolled steel, cast iron	
6	Foot	Iron/stainless steel	

Intended use of motor

The range of motors differentiales general purpose and wash-down motors. These types vary in resistance against humidity and general conditions in the plants. We recommend the use of wash-down motors in case one or more of the following boundary conditions apply:

- Continuous exposure to high-humidity (100 %) environments
- Continuous exposure to saline (5 %) environments
- IP X6 (Water projected in powerful jets – 0.5 inch nozzle – against the enclosure from any direction, Water volume: 26.42 gallons per minute, Pressure: 0.15 psi at distance of 9.84 ft)
- Use of alkaline cleaners such as Potassium Hydroxide or Sodium Hydroxide at low concentrations during wash-down routines
- Presence of animal fats, mineral or vegetable oils, detergents or ethylene glycol

Coating

Components not made of stainless steel are provided with one of the following coatings, depending on the design:

Version	Paint/coating	Coating thickness
Primer	2K epoxy resin	1,181–2,362 µin (30–60 µm)
	KTL coating	591–787 µin (15–20 µm)
Top coating	2K epoxy resin	1,969–2,756 µin (50–70 µm)
	2K polyurethane color	2,362 µin (60 µm)
	KTL coating	591–787 µin (15–20 µm)

Surface design

Selected components are electro-polished in order to improve the surface and protect it against corrosion.

Surface	Electro-polished components
$R_a \leq 125 \mu\text{in}$ (3.2 µm)	Casing
$R_a \leq 32 \mu\text{in}$ (0.8 µm)	All components that come into contact with the pumped fluid

Lantern (motor stool) and cast impeller not electro-polished.

Casing design

Clamp ring

- System pressure up to 230 psi
- Freely selectable discharge port position

Sealing according to the VARIVENT® principle

The special groove ensures that the seal is kept reliably in place at all times. The shape of the groove is based on FEM analyses. The metallic stop allows a defined compression of the seal, ensuring gap-free sealing against the product chamber without dead corners.



O-ring sealing between pump housing and cover

Mechanical seal

GEA Hilge offers the following seal designs:

- Single-acting mechanical seal
- Single-acting flushed mechanical seal (Quench)
- Double-acting mechanical seal

The pumps of the GEA Hilge TPS range are equipped with single internal mechanical seals optimally arranged in the pump.

This ensures efficient lubrication and cooling of the mechanical seal. CIP and SIP-capability is fulfilled according to hygienic design criteria.

The standard material for the mechanical seals is carbon/stainless steel with EPDM elastomers. Other executions and materials are available on request.

For further information on mechanical seals, see page 29.

Design variants

Standard version	Description
GEA Hilge TPS	Horizontal installation, plug-in shaft, standard motor



GEA Hilge TPS on 3-A stainless steel adjustable feet



GEA Hilge TPS on stainless steel adjustable feet

Designs

The following overview lists common designs, installations and versions:

- On 3-A stainless steel adjustable feet
- On stainless steel adjustable feet

Additional versions on request.

Terminal box position

This terminal box positions are possible for all pumps without shroud.

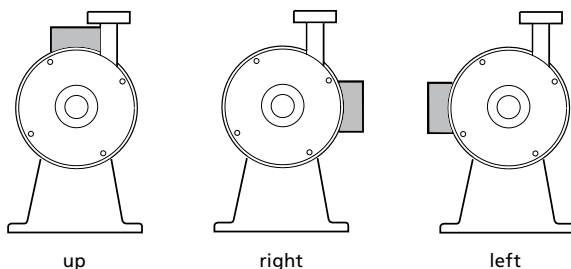

Possible terminal box positions

Positioning of discharge port and terminal box

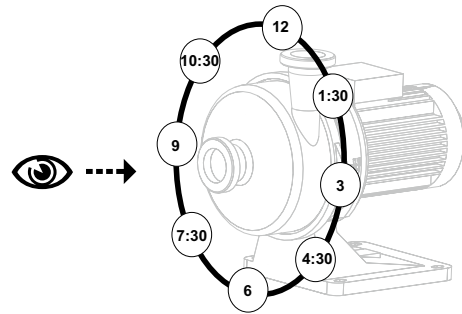

Positioning of discharge port and terminal box for horizontal pumps

Noise emissions

Measured values according to DIN EN ISO 3746 for pump units, measurement uncertainty 3 dB(A).

Type	Lpfa [dB (A)]
TPS 2030	80
TPS 3050	83
TPS 8050	84
TPS 8080	88

The noise emissions of a pump are significantly affected by the given application. The values given here therefore serve only as a guide. Please contact GEA for more detailed information.

Motors

GEA Hilge TPS

P2 [hp]	Frame size	2-pole	4-pole
3.0	182TC	•	•
5.0	184TC	•	•
7.5	213TC	•	•
10.0	215TC	•	•
15.0	254TC	•	
20.0	256TC	•	
25.0	284TSC	•	
30.0	286TSC	•	
40.0	324TSC	•	
50.0	326TSC	•	
60.0	364TSC	•	

Motor protection

Three-phase motors should be connected to a motor-protective circuit breaker.

All three-phase mains-operated standard motors can be connected to an external frequency converter. When a frequency converter is connected, the motor isolation is often overloaded, making the motor louder than during normal operation. In addition, large motors will be exposed to bearing currents caused by the frequency converter.

The following should be taken into account when operating a frequency converter:

- In the event of special noise protection requirements, motor noise can be reduced by using a dU/dt filter between the motor and the frequency converter. For noise-sensitive environments, we recommend using a sinus filter.
- The length of the cable between motor and frequency converter affects the motor load. For this reason, check whether the cable length corresponds to the specifications issued by the supplier of the frequency converter.
- For supply voltages between 500 and 690 V, fit either a dU/dt filter to reduce voltage peaks, or use a motor with reinforced insulation.
- For supply voltages of 690 V, use a motor with reinforced insulation, and fit a dU/dt filter.

Design

The motors are totally enclosed, fan-cooled, C-face standard motors with main dimensions and electrical tolerances acc. NEMA-MG1.

Pump range	Design – NEMA-MG1
GEA Hilge TPS	IM 3001 (IM B5) IM 2001 (IM B35)

Relative air humidity: Max. 95 %

Enclosure class: IP55

Insulation class: F according to NEMA-MG1

Ambient temperature: Max. 104 °F (standard motor)

Motor data	Efficiency class		
	50 Hz	60 Hz	PTC
3.0	NEMA Premium Efficiency (IE3)		•
5.0			•
7.5			•
10.0			•
15.0			•
20.0			•
25.0			•
30.0			•
40.0			•
50.0			•
60.0			•

Selecting according to the application

The table below is intended as a general guide. Selection of connection often depends on on-site conditions.

Connection		Application																
Type	Standard	Beverages					Food				Industrial applications				Cleaning			
		Beer	Wine	Juice	Alcohol	Soft drinks	Confectionery	Dairy products	Frying oil	Syrup	Glue and paint	Purification products	Chemical products	Industrial wastewater and efflux	Surface treatment products	Biofuel	CIP	SIP
Clamps	ASME/ DIN 32676 tri-clamp	•	•	•	•	•	•	•	•	•	•						•	•
	Q-line clamp		•	•	•	•	•	•	•	•							•	
	I-line clamp		•	•	•	•	•	•	•	•							•	•
Flanges	VARIVENT® flange		•	•	•	•	•			•							•	•
	ANSI-B 16.5 flange	•				•			•		•		•	•		•	•	
	DIN 11864-2/ DIN 11853-2 flange		•	•	•	•			•		•		•				•	
Threads	NPT thread										•		•	•		•	•	
	SMS thread		•	•		•												
	ACME bevel thread	•	•	•		•	•	•									•	
	DIN 11851 thread		•	•													•	

- Commonly used connections

Design

The following tables show the design of the different connection types.

Clamps

Applications	Standard	Design	Description of the components
<ul style="list-style-type: none"> Beverage Industry Food Industry Cosmetic Industry Cleaning System (CIP/SIP) 	DIN 32676 Class C (Tri-Clamp® / ASME BPE)		0121a: Clamp connection at pump casing 0121: Clamp connection 0410: Profile gasket 0501: Clamp ring
<ul style="list-style-type: none"> Beverage Industry Food Industry Cosmetic Industry Cleaning System (CIP/SIP) 	I-Line (ASME BPE)		0121a: Clamp connection at pump casing 0121: Clamp connection 0400: Profile gasket 0501: Clamp ring
<ul style="list-style-type: none"> Beverage Industry Food Industry Cleaning System (CIP) 	Q-Line (ASME BPE)		0121a: Clamp connection at pump casing 0121: Clamp connection 0400: Profile gasket 0501: Clamp ring

Flanges

Applications	Standard	Design	Description of the components
Aseptic Flange			
<ul style="list-style-type: none"> Food Industry Beverage Industry Cosmetic Industry Cleaning System (CIP) 	DIN 11864-2/ 11853-2 Form A		0122a: Flanged connection at pump casing 0122: Flanged connection 0412: O-ring 0901: Hexagon head screw 0920: Hexagon nut
Flange			
<ul style="list-style-type: none"> Food Industry Beverage Industry Cleaning System (CIP) 	VARIVENT® (ASME BPE)		0122a: Flanged connection at pump casing 0122: Flanged connection 0412: O-ring 0554: Washer 0901: Hexagon head screw 0920: Hexagon nut
<ul style="list-style-type: none"> Beverage Industry Food Industry Cleaning System (CIP) Industrial Applications 	ANSI-B 16.5 150lb/sq. in		0122a: Flanged connection at pump casing 0122: Flanged connection 0400: Gasket 0554: Washer 0901: Hexagon head screw 0920: Hexagon nut

Threads

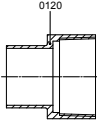
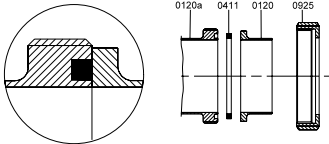
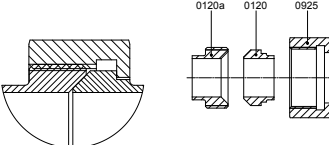
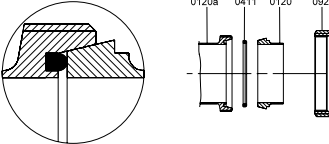
Applications	Standard	Design	Description of the components
<ul style="list-style-type: none"> Industrial Applications Cleaning System (CIP) 	<p>NPT (ASME-BPE)</p>		<p>120: Threaded connection at pump casing</p>
<ul style="list-style-type: none"> Beverage Industry 	<p>SMS (ISO 2037)</p>		<p>0120a: Threaded connection at pump casing 0120: Threaded connection 0411: Joint ring 0925: Grooved union nut</p>
<ul style="list-style-type: none"> Beverage Industry Food Industry Cleaning System (CIP) 	<p>ACME Bevel</p>		<p>0120a: Threaded connection at pump casing 0120: Threaded connection 0925: Grooved union nut</p>
<ul style="list-style-type: none"> Beverage Industry Cleaning System (CIP) 	<p>DIN 11851</p>		<p>0120a: Threaded connection at pump casing 0120: Threaded connection 0411: Joint ring 0925: Grooved union nut</p>

In order to ensure correct operation (depending on the application and the medium), single or single mechanical flushed seal systems can be supplied. The mechanical seal is optimally placed inside the pump. This ensures efficient lubrication and cooling of the mechanical seal, while also

ensuring CIP (Cleaning In Place) and SIP (Sterilization In Place) capability. The standard material for the mechanical seals are carbon/stainless steel or SiC/SiC with EPDM or FKM (Viton) elastomers.

Mechanical seals

The operating range of the seal depends on the liquid, the type of seal, the operating pressure and the liquid temperature.

The seal types described below are standard seal types; other seals are available on request.

Version	Material pairs stationary seal face/O-rings	Max. pressure	Max. temperature
Encapsulated spring	silicon carbide /silicon carbide /EPDM silicon carbide /silicon carbide /FKM carbon/stainless steel/EPDM carbon/stainless steel/FKM carbon/SiC/EPDM carbon/SiC/FKM	232 psi	23 to 212 °F

Special seals available in different materials up to 365 psi.

Mechanical seal arrangements

Arrangement	Design	Components
Double-acting mechanical seal		11: Slide ring holder 120.1: Face seal ring, primary 120.5: Stationary seal ring 120.6: Face seal, secondary
Single-acting mechanical seal		100.1: Face seal ring 100.2: Stationary seal ring 110.6: Spring
Single-acting mechanical seal, flushed		11: Slide ring holder 100.1: Face seal ring 100.2: Stationary seal ring 110.1: Shaft protection sleeve 110.2: Shaft seal 110.6: Spring

Mechanical installation

GEA Hilge TPS

Never install the pump vertically!

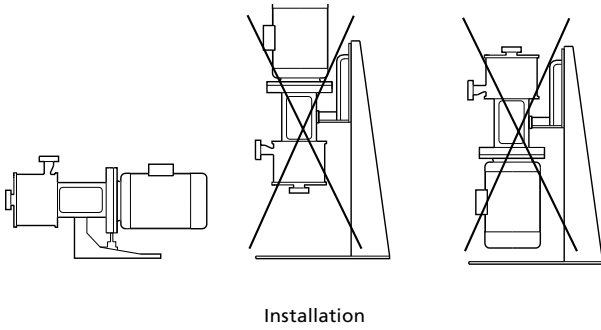

Space requirements

Horizontal installation

- Pumps fitted with motors up to and including 5.0 hp require an 11.81 inch clearance behind the motor.
- Pumps fitted with motors of 7.5 hp and up require at least a 1 meter clearance above the motor and 11.81 inch behind it to allow the use of lifting equipment.

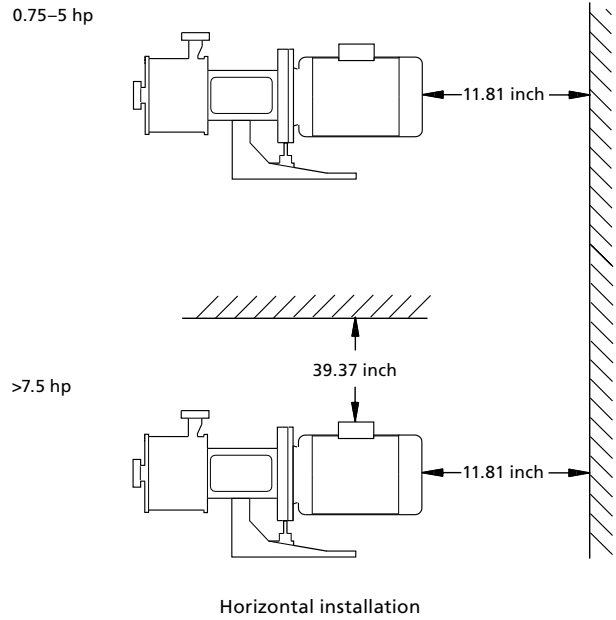

Elimination of noise and vibrations

In order to achieve optimum operation and minimum noise and vibration, consider vibration dampening of the pump. Generally, always consider this for pumps with motors above 15 hp. Smaller motors, however, may also cause undesirable noise and vibration.

Noise and vibration are generated by the rotation in the motor and pump and by the flow in the pipework and fittings. The effect on the environment is subjective and depends on correct installation and the state of the remaining system.

Foundation

Vibration dampening is best achieved by installing the pumps on a plane and rigid concrete foundation.

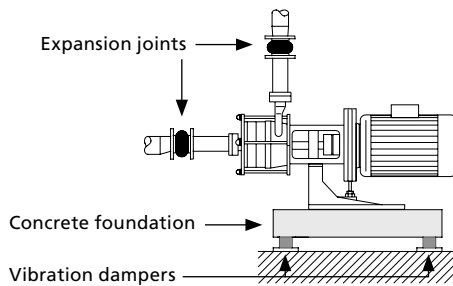

Example of a pump foundation

As a guideline, the weight of the concrete foundation should be 1.5 times the pump weight.

Vibration dampers

To prevent vibrations from being transmitted to the building, we recommend that you isolate the pump foundation from buildings by means of vibration dampers.

The selection of the correct vibration dampers requires the following data:

- Forces that will be transmitted through the vibration dampers
- Motor speed, taking speed control into account as needed
- Required dampening in % (suggested value is 70 %).

The right damper varies from installation to installation, and the wrong damper may increase the vibration level. Vibration dampers should therefore be sized by the supplier.

Expansion joints

If the pump is installed on a pedestal with vibration dampers, expansion joints must always be fitted on the pipeline connections. This is important to prevent the pump from "hanging" in the connections.

Install expansion joints in order to

- absorb expansion/contractions in the pipework caused by variable liquid temperatures
- reduce mechanical strains that occur in connection with pressure surges in the plant
- isolate mechanical structure-borne noise in the pipework (only rubber bellows expansion joints).

Note: Do not install expansion joints to compensate for inaccuracies in the pipework such as center displacement of flanges.

Fit expansion joints at a distance of at least 1 to 1.5 times the nominal flange diameter away from the pump on the suction as well as on the discharge side. This will prevent the development of turbulence in the expansion joints, resulting in better suction conditions and a minimum pressure loss on the discharge side.

We always recommend expansion joints with limiting rods for flanges larger than DN 100/4".

The pipes should be anchored so that they do not stress the expansion joints and the pump. Follow the supplier's instructions and pass them on to advisers or pipe installers.

The values for density and viscosity given here are ratios and can deviate in practice.

Application beer

				Mechanical seal* material product side / atmospheric side		
Subgroup	Temperature [°F]	Density [lb/gal]	Viscosity [CPS]	Single	Quench	Tandem
Altbier	< 212	10	1	aeE (up to 145 psi), aiH (from 145 psi)	-	-
Beer						
Beer mix						
Berliner Weisse						
Bock beer						
Craft beer						
Export beer						
Full beer (Vollbier)						
Green beer						
Herb beer						
Lager						
Light beer						
Martzen (Märzen)						
Non-alcoholic beer						
Pils						
Pilsener						
Ringed (Kräusen)						
Wheat beer						
Cold wort	< 104	< 11	< 5	aeE (up to 145 psi), aiH (from 145 psi)	-	-
Original wort	< 212	< 11	< 5	-	kiE/WDR	kiE/aeE
Hop extract (dissolved)	104-194	< 11	< 5	-	kiE/WDR	kiE/aeE
Lees	104-239	< 11	< 5	-	kiE/WDR	kiE/aeE
Mash (beer)	< 68	< 11	< 100	aeE	-	-
Lauter wort	< 140	< 11	< 5	aeE	-	-
Hot wort	< 212	< 11	< 5	kiV (up to 233 psi), kil (up to 363 psi)	-	-
Crop yeast	< 212	< 12	< 5	kiV (up to 233 psi), kil (up to 363 psi)	-	-
Pitching yeast						
Yeast						
Enzymes (watery dissolution)						
Lactic acid, con. < 50% (C ₃ H ₆ O ₃)						
Lactic acid, con. > 50% (C ₃ H ₆ O ₃)						

Application water

				Mechanical seal* material product side / atmospheric side		
Subgroup	Temperature [°F]	Density [lb/gal]	Viscosity [CPS]	Single	Quench	Tandem
Iced water	25 to 37	< 10	1	kiE (up to 145 psi), kiH (from 145 psi)	-	-
Cold water	< 230	< 10	1	aeE (up to 145 psi), aiH (from 145 psi)	-	-
Deminerlized water (Not for sterile applications)						
Drinking water						
Flushing water						
Hot water						
Mineral water						
Process water						
Service water						
Water						

Application wine/sparkling wine

				Mechanical seal* material product side / atmospheric side		
Subgroup	Temperature [°F]	Density [lb/gal]	Viscosity [CPS]	Single	Quench	Tandem
Champagne	< 95	< 10	1	aeE (up to 145 psi), aiH (from 145 psi)	-	-
Cherry wine						
Cider						
Cidre						
Dry sparkling wine						
Fruit wine						
Prosecco						
Red wine						
Rosé wine						
Sparkling wine						
Strawberry wine						
White wine						
Wine						
Young wine						
Dessert wine	< 95	< 11	15	aeE (up to 145 psi), aiH (from 145 psi)	-	-
Dessert wine, late-harvest wine						
Drape must (w/o. particles)						
Ice wine	< 95	< 11	100	aeE (up to 145 psi), aiH (from 145 psi)	-	-
Wine lees						
Wine yeast						
Mash (wine)	< 95	< 11	5	aeE (up to 145 psi), aiH (from 145 psi)	-	-

Application coffee/tea/cocoa

				Mechanical seal* material product side / atmospheric side			
Subgroup	Temperature [°F]	Density [lb/gal]	Viscosity [CPS]	Single	Quench	Tandem	Encapsulated seal for vacuum application
Coffee	< 257	10	1	aeE	-	-	
Coffee extract	< 176–212	< 12	< 250	-	-	kiV/aeV	x
Tea	< 257	10	1	aeE	-	-	
Fruit tea / flavored tea	< 257	10	1	aeE	-	-	
Cocoa drink	< 104	12	< 10	aeE	-	-	

* aeE: carbon/stainless steel/EPDM, aeV: carbon/stainless steel/Viton, aiH: carbon/SiC/EPDM (USP-Class VI), kiE: SiC/SiC/EPDM, kiH: SiC/SiC/EPDM (USP-Class VI), kil: SiC/SiC/Viton (USP Class VI), kiV: SiC/SiC/Viton, WDR: lip seal. The elastomer of the static seals equals the elastomer of the mechanical seals.

Application milk

Subgroup	Temperature [°F]	Density [lb/gal]	Viscosity [CPS]	Mechanical seal* material product side / atmospheric side		
				Single	Quench	Tandem
Buttermilk	< 131	< 11	< 10	aeE (up to 145 psi), aiH (from 145 psi)	–	–
	> 131 – < 212	< 11	< 5	–	aeE/WDR (up to 145 psi), aiH/WDR (from 145 psi)	aeE/aeE (up to 145 psi), aiH/aeE (from 145 psi)
UHT milk	< 131	< 11	< 10	aeE (up to 145 psi), aiH (from 145 psi)	–	–
	> 131 – < 212	< 11	< 5	–	aeE/WDR (up to 145 psi), aiH/WDR (from 145 psi)	aeE/aeE (up to 145 psi), aiH/aeE (from 145 psi)
Yoghurt milk	< 131	< 11	< 10	aeE (up to 145 psi), aiH (from 145 psi)	–	–
	> 131 – < 212	< 11	< 5	–	aeE/WDR (up to 145 psi), aiH/WDR (from 145 psi)	aeE/aeE (up to 145 psi), aiH/aeE (from 145 psi)
Kefir	< 131	< 11	< 10	aeE (up to 145 psi), aiH (from 145 psi)	–	–
	> 131 – < 212	< 11	< 5	–	aeE/WDR (up to 145 psi), aiH/WDR (from 145 psi)	aeE/aeE (up to 145 psi), aiH/aeE (from 145 psi)
Cheese milk	< 131	< 11	< 10	aeE (up to 145 psi), aiH (from 145 psi)	–	–
	> 131 – < 212	< 11	< 5	–	aeE/WDR (up to 145 psi), aiH/WDR (from 145 psi)	aeE/aeE (up to 145 psi), aiH/aeE (from 145 psi)
Skimmed milk	< 131	< 11	< 10	aeE (up to 145 psi), aiH (from 145 psi)	–	–
	> 131 – < 212	< 11	< 5	–	aeE/WDR (up to 145 psi), aiH/WDR (from 145 psi)	aeE/aeE (up to 145 psi), aiH/aeE (from 145 psi)
Skimmed milk concentrate	< 131	< 11	< 10	aeE (up to 145 psi), aiH (from 145 psi)	–	–
	> 131 – < 212	< 11	< 5	–	aeE/WDR (up to 145 psi), aiH/WDR (from 145 psi)	aeE/aeE (up to 145 psi), aiH/aeE (from 145 psi)
Milk	< 131	< 11	< 10	aeE (up to 145 psi), aiH (from 145 psi)	–	–
	> 131 – < 212	< 11	< 5	–	aeE/WDR (up to 145 psi), aiH/WDR (from 145 psi)	aeE/aeE (up to 145 psi), aiH/aeE (from 145 psi)
Milk concentrate	< 131	< 11	< 10	aeE (up to 145 psi), aiH (from 145 psi)	–	–
	> 131 – < 212	< 11	< 5	–	aeE/WDR (up to 145 psi), aiH/WDR (from 145 psi)	aeE/aeE (up to 145 psi), aiH/aeE (from 145 psi)
Lactic culture	< 131	< 11	< 10	aeE (up to 145 psi), aiH (from 145 psi)	–	–
	> 131 – < 212	< 11	< 5	–	aeE/WDR (up to 145 psi), aiH/WDR (from 145 psi)	aeE/aeE (up to 145 psi), aiH/aeE (from 145 psi)
Milk mix	< 131	< 11	< 10	aeE (up to 145 psi), aiH (from 145 psi)	–	–
	> 131 – < 212	< 11	< 5	–	aeE/WDR (up to 145 psi), aiH/WDR (from 145 psi)	aeE/aeE (up to 145 psi), aiH/aeE (from 145 psi)
Whey	< 131	< 11	< 10	aeE (up to 145 psi), aiH (from 145 psi)	–	–
	> 131 – < 212	< 11	< 5	–	aeE/WDR (up to 145 psi), aiH/WDR (from 145 psi)	aeE/aeE (up to 145 psi), aiH/aeE (from 145 psi)
Raw milk	< 131	< 11	< 10	aeE (up to 145 psi), aiH (from 145 psi)	–	–
	> 131 – < 212	< 11	< 5	–	aeE/WDR (up to 145 psi), aiH/WDR (from 145 psi)	aeE/aeE (up to 145 psi), aiH/aeE (from 145 psi)
Pre-stirred yoghurt	< 131	< 11	< 10	aeE (up to 145 psi), aiH (from 145 psi)	–	–
	> 131 – < 212	< 11	< 5	–	aeE/WDR (up to 145 psi), aiH/WDR (from 145 psi)	aeE/aeE (up to 145 psi), aiH/aeE (from 145 psi)
Sour milk	< 131	< 11	< 10	aeE (up to 145 psi), aiH (from 145 psi)	–	–
	> 131 – < 212	< 11	< 5	–	aeE/WDR (up to 145 psi), aiH/WDR (from 145 psi)	aeE/aeE (up to 145 psi), aiH/aeE (from 145 psi)

				Mechanical seal* material product side / atmospheric side		
Subgroup	Temperature [°F]	Density [lb/gal]	Viscosity [CPS]	Single	Quench	Tandem
Sour cream with thickening agents	< 131	< 11	< 10	aeE (up to 145 psi), aiH (from 145 psi)	–	–
	> 131 – < 212	< 11	< 5	–	aeE/WDR (up to 145 psi), aiH/WDR (from 145 psi)	aeE/aeE (up to 145 psi), aiH/aeE (from 145 psi)
Full cream milk	< 131	< 11	< 10	aeE (up to 145 psi), aiH (from 145 psi)	–	–
	> 131 – < 212	< 11	< 5	–	aeE/WDR (up to 145 psi), aiH/WDR (from 145 psi)	aeE/aeE (up to 145 psi), aiH/aeE (from 145 psi)
Coffee cream	< 131	< 11	< 40	aeV (up to 145 psi), ail (from 145 psi)	–	–
	> 131 – < 212	< 11	< 20	–	aeV/WDR (up to 145 psi), ail/WDR (from 145 psi)	aeV/aeV (up to 145 psi), ail/aeV (from 145 psi)
Whipping cream	< 131	< 11	< 40	aeV (up to 145 psi), ail (from 145 psi)	–	–
	> 131 – < 212	< 11	< 20	–	aeV/WDR (up to 145 psi), ail/WDR (from 145 psi)	aeV/aeV (up to 145 psi), ail/aeV (from 145 psi)
Sour cream	< 131	< 11	< 40	aeV (up to 145 psi), ail (from 145 psi)	–	–
	> 131 – < 212	< 11	< 20	–	aeV/WDR (up to 145 psi), ail/WDR (from 145 psi)	aeV/aeV (up to 145 psi), ail/aeV (from 145 psi)
Cream	< 131	< 11	< 40	aeV (up to 145 psi), ail (from 145 psi)	–	–
	> 131 – < 212	< 11	< 20	–	aeV/WDR (up to 145 psi), ail/WDR (from 145 psi)	aeV/aeV (up to 145 psi), ail/aeV (from 145 psi)
Condensed milk	< 131	< 11	< 40	aeV (up to 145 psi), ail (from 145 psi)	–	–
	> 131 – < 212	< 11	< 20	–	aeV/WDR (up to 145 psi), ail/WDR (from 145 psi)	aeV/aeV (up to 145 psi), ail/aeV (from 145 psi)

Application vinegar/sauces/marinade

				Mechanical seal* material product side / atmospheric side		
Subgroup	Temperature [°F]	Density [lb/gal]	Viscosity [CPS]	Single	Quench	Tandem
Soy sauce	41–203	13	25	kiE	–	–
	203–257	13	25	–	kiE/WDR	kiE/aeE
Cider vinegar						
Herb-flavored vinegar						
Vinegar	140	10	1	aeE	–	–
Wine vinegar						
Vinegar essence	140	11	1	aeV	–	–

* aeE: carbon/stainless steel/EPDM, aeV: carbon/stainless steel/Viton, aiH: carbon/SIC/EPDM (USP-Class VI), ail: carbon/SIC/Viton (USP-Class VI), kiE: SIC/SIC/EPDM, WDR: lip seal. The elastomer of the static seals equals the elastomer of the mechanical seals.

Application non-alcoholic drink

Subgroup	Temperature [°F]	Density [lb/gal]	Viscosity [CPS]	Mechanical seal* material product side / atmospheric side			
				Single	Quench	Tandem	Encapsulated seal
Apple juice	< 158	10	< 50	aeE	-	-	
	< 158	10	< 50	aeE	-	-	x
	< 158	10	< 50	kiE	-	-	x
	> 158 – < 203	10	< 10	-	kiE/WDR	kiE/aeE	
	> 158 – < 203	10	< 10	-	kiE/WDR	kiE/aeE	x
Apricot /mango juice	< 158	10	< 50	aeE	-	-	
	< 158	10	< 50	aeE	-	-	x
	< 158	10	< 50	kiE	-	-	x
	> 158 – < 203	10	< 10	-	kiE/WDR	kiE/aeE	
	> 158 – < 203	10	< 10	-	kiE/WDR	kiE/aeE	x
Cherry juice	< 158	10	< 50	aeE	-	-	
	< 158	10	< 50	aeE	-	-	x
	< 158	10	< 50	kiE	-	-	x
	> 158 – < 203	10	< 10	-	kiE/WDR	kiE/aeE	
	> 158 – < 203	10	< 10	-	kiE/WDR	kiE/aeE	x
Cola	< 212	10	< 5	aeE	-	-	
	< 212	10	< 5	aeE	-	-	
Concentrated lemon juice, without pulp and granules	< 158	10	25	kiV	-	-	
Cranberry juice	< 158	10	< 50	aeE	-	-	
	< 158	10	< 50	aeE	-	-	x
	< 158	10	< 50	kiE	-	-	x
	> 158 – < 203	10	< 10	-	kiE/WDR	kiE/aeE	
	> 158 – < 203	10	< 10	-	kiE/WDR	kiE/aeE	x
Fruit juice, with granules	< 158	10	< 50	kiE	-	-	x
Fruit juice, with pulp		10	< 50	aeE	-	-	x
Fruit juice, with pulp and with granules	> 158 – < 203	10	< 10	-	kiE/WDR	kiE/aeE	x
Fruit juice, without pulp	< 158	10	< 50	aeE	-	-	
	> 158 – < 203	10	< 10	-	kiE/WDR	kiE/aeE	
Grape juice	< 158	10	< 50	aeE	-	-	
	< 158	10	< 50	aeE	-	-	x
	< 158	10	< 50	kiE	-	-	x
	> 158 – < 203	10	< 10	-	kiE/WDR	kiE/aeE	
	> 158 – < 203	10	< 10	-	kiE/WDR	kiE/aeE	x
Iced tea	< 212	10	< 5	aeE	-	-	
Lemon juice, with pulp and granules	< 158	10	25	kiV	-	-	x
Lemon juice, without pulp and granules	< 158	10	25	aeV	-	-	
Lemonade	< 212	10	< 5	aeE	-	-	
	< 212	10	< 5	aeE	-	-	
Mineral water	< 212	10	< 5	aeE	-	-	
	< 212	10	< 5	aeE	-	-	
Multivitamin juice	< 158	10	< 50	aeE	-	-	
	< 158	10	< 50	aeE	-	-	x
	> 158 – < 203	10	< 10	-	kiE/WDR	kiE/aeE	
	> 158 – < 203	10	< 10	-	kiE/WDR	kiE/aeE	x
Orange juice	< 158	10	< 50	aeE	-	-	
	< 158	10	< 50	aeE	-	-	x
	< 158	10	< 50	kiE	-	-	x
	> 158 – < 203	10	< 10	-	kiE/WDR	kiE/aeE	
	> 158 – < 203	10	< 10	-	kiE/WDR	kiE/aeE	x
Peach/passion fruit juice	< 158	10	< 50	aeE	-	-	
	< 158	10	< 50	aeE	-	-	x
	< 158	10	< 50	kiE	-	-	x
	> 158 – < 203	10	< 10	-	kiE/WDR	kiE/aeE	
	> 158 – < 203	10	< 10	-	kiE/WDR	kiE/aeE	x

				Mechanical seal* material product side / atmospheric side			
Subgroup	Temperature [°F]	Density [lb/gal]	Viscosity [CPS]	Single	Quench	Tandem	Encapsulated seal
Raspberry/strawberry juice	< 158	10	< 50	aeE	–	–	
	< 158	10	< 50	aeE	–	–	x
	< 158	10	< 50	kiE	–	–	x
	> 158 – < 203	10	< 10	–	kiE/WDR	kiE/aeE	
	> 158 – < 203	10	< 10	–	kiE/WDR	kiE/aeE	x
Vegetable juice, with pulp and granules	< 158	11	< 50	kiV	–	–	x
	> 158 – < 203	11	< 10	–	–	kiV/aeV	x
Vegetable juice, without pulp and granules	< 158	11	< 50	aeV	–	–	
	> 158 – < 203	11	< 10	–	–	kiV/aeV	

Application concentrated fruit juice

					Mechanical seal* material product side / atmospheric side		
Subgroup	Temperature [°F]	Density [lb/gal]	Viscosity [CPS]	Concentration [Brix]	Single	Quench	Tandem
Concentrated fruit juice	41–194	12	related to temperature	to 25°	aeE (up to 145 psi), aiH (from 145 psi)	–	–
	41–104	12		26–49°	aeE (up to 145 psi), aiH (from 145 psi)	–	–
	104–194	12		26–49°	–	aeE/WDR	aeE/aeE
	59–104	12		50°	aeE (up to 145 psi), aiH (from 145 psi)	–	–
	104–194	12		50°	–	aeE/WDR	aeE/aeE
	59–104	13		55°	aeE (up to 145 psi), aiH (from 145 psi)	–	–
	104–194	13		55°	–	aeE/WDR	aeE/aeE
	59–104	13		60°	aeE (up to 145 psi), aiH (from 145 psi)	–	–
	104–194	13		60°	–	aeE/WDR	aeE/aeE
	59–104	13		65°	aeE (up to 145 psi), aiH (from 145 psi)	–	–
	104–194	13		65°	–	aeE/WDR	aeE/aeE
	68–104	14		70°	aeE (up to 145 psi), aiH (from 145 psi)	–	–
	104–194	14		70°	–	aeE/WDR	aeE/aeE

* aeE: carbon/stainless steel/EPDM, aeV: carbon/stainless steel/Viton, aiH: carbon/SiC/EPDM (USP-Class VI), kiE: SiC/SiC/EPDM, kiH: SiC/SiC/EPDM (USP-Class VI), kiV: SiC/SiC/Viton, WDR: lip seal. The elastomer of the static seals equals the elastomer of the mechanical seals.

Application oil

Subgroup	Temperature [°F]	Density [lb/gal]	Viscosity [CPS]	Mechanical seal* material product side / atmospheric side								
				Single	Quench	Tandem						
Cocoa butter	50–86	9	< 80	aeV	–	–						
Coconut oil / copra oil												
Corn oil												
Cotton seed oil												
Linseed oil												
Olive oil												
Palm oil												
Peanut oil												
Pumpkin seed oil												
Rape oil / rapeseed oil												
Safflower oil												
Sesame oil							86–257	9	< 40	aeV	–	–
Soy oil / soy bean oil												
Sunflower oil												
Walnut oil												
Wheat germ oil	< 338	9	10		–	–						
Chip fat												
Butter oil (liquid)							> 113–248	9	45	aeV	–	–
Lard (liquid)							> 113–248	9	45	aeV	–	–
Liquid butter							> 95–248	9	45	aeV	–	–
Fish oil							50–257	10	< 100	aeV	–	–
Whale oil							50–257	10	< 100	aeV	–	–
Cod liver (cod-liver oil)							50–257	10	< 100	aeV	–	–
Mineral oil							50–212			aeV	–	–
Motor oil												
Petroleum												
Derv							50–212	9	< 15	aeV	–	–
Diesel oil												
Oil-in-water emulsion												

Application spirits

Subgroup	Temperature [°F]	Density [lb/gal]	Viscosity [CPS]	Concentration [%]	Mechanical seal* material product side / atmospheric side		
					Single	Quench	Tandem
Spirits	104	10	< 5		aeE (up to 145 psi), aiH (from 145 psi)	–	–
	< 122	12	< 150		–	aeE/WDR	kiE/aeE
	< 212	12	< 100		–	aeE/WDR	kiE/aeE
	< 172	10	1	< 10	aeE (up to 145 psi), aiH (from 145 psi)	–	–
	< 172	9	1	< 50	aeE (up to 145 psi), aiH (from 145 psi)	–	–
	< 172	8	1	< 98	aeE (up to 145 psi), aiH (from 145 psi)	–	–

Application cleaning in place (CIP)

Subgroup	Temperature [°F]	Density [kg/m³]	Viscosity [mPas]	Concentration [%]	Mechanical seal* material product side / atmospheric side		
					Single	Quench	Tandem
CIP liquid (concentration approx. 5%)	< 212	11	< 5	< 5	aeE (up to 145 psi), aiH (from 145 psi)	–	–

Application sugar syrup

					Mechanical seal* material product side / atmospheric side		
Subgroup	Temperature [°F]	Density [lb/gal]	Viscosity [mPas]	Concentration [Brix]	Single	Quench	Tandem
Sugar syrup without crystals	41–194	12	related to temperature	to 25°	aeE (up to 145 psi), aiH (from 145 psi)	–	–
	41–104	12		26–49°	aeE (up to 145 psi), aiH (from 145 psi)	–	–
	104–194	12		26–49°	0	aeE/WDR	aeE/aeE
	59–104	12		50°	aeE (up to 145 psi), aiH (from 145 psi)	–	–
	104–194	12		50°	0	aeE/WDR	aeE/aeE
	59–104	13		55°	aeE (up to 145 psi), aiH (from 145 psi)	–	–
	104–194	13		55°	0	aeE/WDR	aeE/aeE
	59–104	13		60°	aeE (up to 145 psi), aiH (from 145 psi)	–	–
	104–194	13		60°	0	aeE/WDR	aeE/aeE
	59–104	13		65°	aeE (up to 145 psi), aiH (from 145 psi)	–	–
	104–194	13		65°	0	aeE/WDR	aeE/aeE
	68–104	14		70°	aeE (up to 145 psi), aiH (from 145 psi)	–	–
	104–194	14		70°	0	aeE/WDR	aeE/aeE
	68–104	14		72,7°	aeE (up to 145 psi), aiH (from 145 psi)	–	–
	104–194	14		72,7°	0	aeE/WDR	aeE/aeE
	41–194	12		to 25°	kiE (up to 145 psi), kiH (10 – 233 psi)	–	–
	41–104	12		26–49°	kiE (up to 145 psi), kiH (10 – 233 psi)	–	–
	104–194	12		26–49°	0	kiE/WDR	kiE/aeE
	59–104	12		50°	kiE (up to 145 psi), kiH (10 – 233 psi)	–	–
	104–194	12		50°	0	kiE/WDR	kiE/aeE
	59–104	13		55°	kiE (up to 145 psi), kiH (10 – 233 psi)	–	–
	104–194	13		55°	0	kiE/WDR	kiE/aeE
	59–104	13		60°	kiE (up to 145 psi), kiH (10 – 233 psi)	–	–
	104–194	13		60°	0	kiE/WDR	kiE/aeE
	59–104	13		65°	kiE (up to 145 psi), kiH (10 – 233 psi)	–	–
	104–194	13		65°	0	kiE/WDR	kiE/aeE
	68–104	14		70°	kiE (up to 145 psi), kiH (10 – 233 psi)	–	–
	104–194	14		70°	0	kiE/WDR	kiE/aeE

* aeE: carbon/stainless steel/EPDM, aeV: carbon/stainless steel/Viton, aiH: carbon/SiC/EPDM (USP-Class VI), kiE: SiC/SiC/EPDM, kiH: SiC/SiC/EPDM (USP-Class VI), WDR: lip seal. The elastomer of the static seals equals the elastomer of the mechanical seals.

Application chemicals

2 Subgroup	Temperature [°F]	Density [lb/gal]	Viscosity [CPS]	Concentration [%]	Mechanical seal* material product side / atmospheric side		
					Single	Quench	Tandem
Caustic soda (NaOH)	< 140	related to concentration		< 15	kiE	-	-
	< 140	related to concentration		> 15 - < 50	-	kiE/WDR	kiE/aeE
	> 140 - < 214	related to concentration		< 12	kiE	-	-
Phosphoric acid (H ₃ PO ₄)	> 140 - < 214	related to concentration		< 12 - < 50	-	kiE/WDR	kiE/aeE
	< 104	1% = 10	< 5	< 15	kiV	-	-
	> 104 - < 185	5% = 10	< 5	< 15	-	kiV/WDR	kiV/aeV
	< 185	10% = 11	< 5	> 15 - < 45	-	-	kiV/aeV
Nitric acid (HNO ₃)	32-68	1% = 10	5	0-10	kiV	-	-
	68-104	5% = 10	5	0-10	-	kiV/WDR	kiV/aeV
	32-104	10% = 10	5	10.1-20	-	kiV/WDR	kiV/aeV
	104-185	20% = 11	5	0-20	-	-	kiV/aeV
	32-185	30% = 12	5	20.1-40	-	-	kiV/aeV
High test peroxide (H ₂ O ₂) Hydrogen peroxide	< 194	< 11	2	2-3	aeV	-	-
	< 194	< 12	2	< 40	kiV	-	-
	< 194	< 13	2	< 60	kiV	-	-
	< 140	< 15	2	< 100	-	-	kiV/aeV
Brine solution Common salt solution Sodium chloride (NaCl)	< 86	< 11	< 5	< 5	aeE	-	-
	86-104	< 11	< 5	< 5	kiE	-	-
	< 104	< 11	< 5	5.1-10	kiE	-	-
Curing brine (butchery)	< 104	< 12	< 25	10.1-25	-	kiE/WDR	kiE/aeE
	< 104	12	< 300	< 20	kiE	-	-
Salting brine (cheese dairy)	< 104	13	< 60	20-30	-	kiE/WDR	kiE/aeE
Ammonia/ammoniac (NH ₃)	< 104	8	< 5		-	aeE/WDR	aeE/aeE
Caustic potash (KOH) Potassium hydroxide	< 140	< 11	< 5	< 10	kiE	-	-
	< 140	< 12	< 5	< 20	kiE	-	-
Glycerol Propanetriol	80	< 11	< 5	0-40	aeV	-	-
	80	< 12	< 20	40.1-60	aeV	-	-
	80	< 12	< 50	60.1-75	aeV	-	-
	80	< 12	< 100	75.1-85	aeV	-	-
Propylene-glycol (C ₃ H ₈ O ₂)	32-176	10	< 5	1-20	kiV	-	-
	23-176	10	< 20	20.1-50	kiV	-	-
	14-176	10	< 150	50.1-75	kiV	-	-
	14-0	11	< 255	75.1-100	kiV	-	-
	32-176	11	< 150	75.1-100	kiV	-	-
Ethanediol Ethylene-glycol (C ₂ H ₆ O ₂)	32-176	10	< 5	1-20	kiE	-	-
	23-176	11	< 20	20.1-50	kiE	-	-
	14-176	11	< 40	50.1-75	kiE	-	-
	14-32	11	< 100	75.1-100	kiE	-	-
	32-176	11	< 65	75.1-100	kiE	-	-
Citric acid (C ₆ H ₈ O ₇) Natural citric acid	41-176	1% = 10	< 15	< 10	kiV	-	-
	41-176	10% = 10	< 15	10.1-50	kiV	-	-
Acetic acid (C ₂ H ₄ O ₂)	41-176	10.1% = 11	1	< 10	aeE	-	-
	41-212	20% = 11	1	10.1-100	-	-	aeK/aeE
		30% = 11					
		50% = 13					

* aeE: carbon/stainless steel/EPDM, aeK: carbon/stainless steel/FFKM, aeV: carbon/stainless steel/Viton, kiE: SIC/SIC/EPDM, kiV: SIC/SIC/Viton. The elastomer of the static seals equals the elastomer of the mechanical seals.



**GEA Hilge TPS
Single-stage
self-priming
centrifugal pumps**

2-pole

50 Hz 1

60 Hz 2

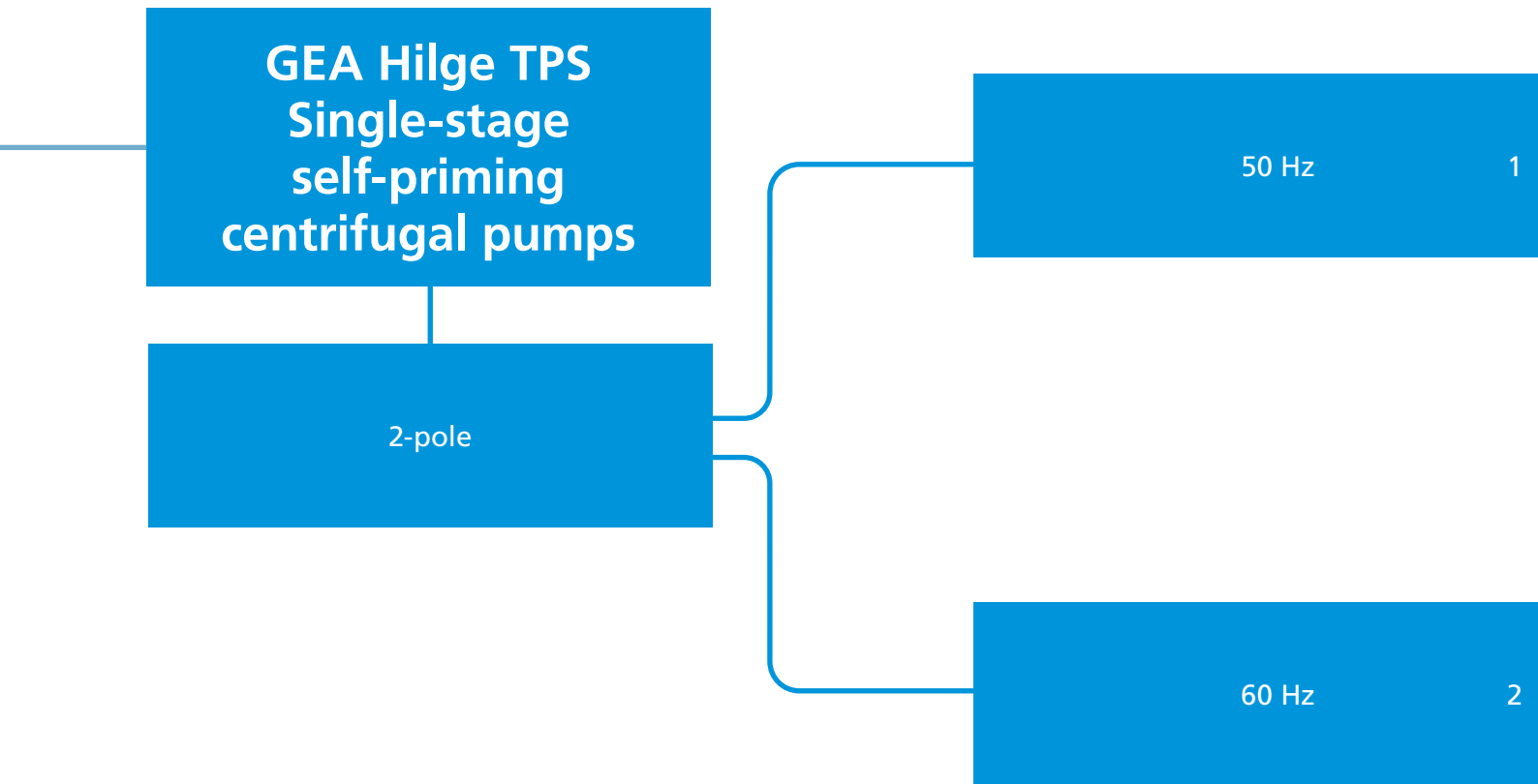



**GEA Hilge TPS
2-pole
50 Hz**

GEA Hilge TPS 2030

GEA Hilge TPS 3050

GEA Hilge TPS 8050

GEA Hilge TPS 8080



Technical data of the standard version

Materials	Pump housing: 316L (1.4404), deep-drawn Impeller: 316L (1.4409), precision casting
Connections	Tri-Clamp ASME BPE/DIN 32676
Nominal width of connections	Suction side 2 1/2"; 2", pressure side 1 1/2"; 2"
Mechanical seal	Single-acting, material C / SIC / EPDM
Static seals	EPDM (FDA, USP Class VI, 3-A)
Motor	Standard motor: NEMA-Motor, 3-phase, 208-230V/460V, C-face with foot, IP55, ISO-Class F, incl. PTC thermostat, premium efficiency
Documentation	Operating instructions, declaration of conformity
Flow rate	Max. 32 m³/h (141 US gpm)
Pump head	Max. 37 m (121 ft)
Housing pressure	Max. 16 bar (232 psi)
Certificates	



Further options see page 74 (Composition of Order Code)

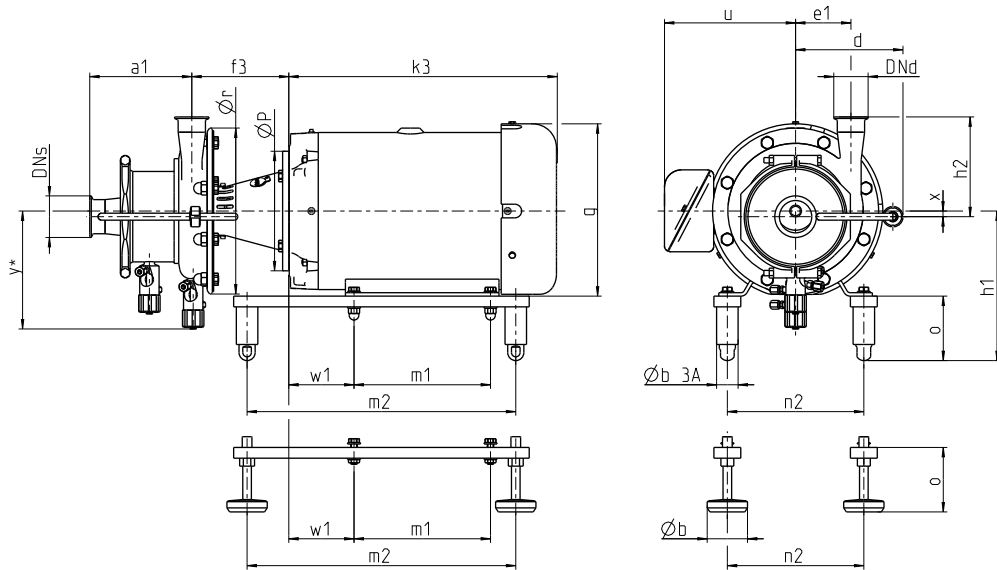

e1 = 3.35 inch
 Ør = 10.20 inch
 x = 0.39 inch
 d = 6.94 inch

Dimensions																	
Frame Size	Power [hp]	k3 [inch]	f3 [inch]	h1 +/- 0.4* [inch]	o +/- 0.4* [inch]	Y* [inch]	ØP [inch]	u [inch]	g [inch]	m1 [inch]	m2 [inch]	n2 [inch]	w1 [inch]	w2 [inch]	Øb _{3A} [inch]	Øb [inch]	Weight [lb]
143TC	1.5	11.33	4.98	8.74	5.24	7.76	4.50	5.87	7.33	5.00	11.61	5.50	2.75	5.26	0.87	1.97	91.00
145TC	2.0	11.73	4.98	8.74	5.24	0.39	4.50	5.87	7.33	5.00	11.61	5.50	2.75	5.26	0.87	1.97	93.00
182TC	3.0	13.59	6.18	9.74	5.24	0.10	8.50	6.70	9.22	5.50	12.20	7.50	3.50	5.57	0.87	1.97	117.00
184TC	5.0	15.16	6.18	9.74	5.24	3.35	8.50	6.70	9.22	5.50	12.20	7.50	3.50	5.57	0.87	1.97	133.00
213TC	7.5	16.70	6.18	10.01	4.76	6.94	8.50	7.97	10.91	7.00	16.14	8.50	4.25	7.81	0.87	1.97	187.00
215TC	10.0	18.27	6.18	10.01	4.76	5.53	8.50	7.97	10.91	7.00	16.14	8.50	4.25	7.81	0.87	1.97	216.00
254TC	15.0	18.56	6.80	10.97	4.72	4.93	8.50	9.45	12.84	10.00	19.69	10.00	4.75	8.82	1.18	2.95	248.00

Connections											
DNs 2" OD, DNd 1 1/2" OD	DIN 32676 clamp	Q-line clamp	I-line clamp	H-line clamp	VARIVENT® flange	ANSI 16.4 flange	DIN 11851 thread	SMS thread	ACME bevel thread	NPT thread	
a1	6.65	6.47	6.69	6.53	6.52	8.28	7.11	6.48	6.66	7.68	
h2	6.44	5.88	6.26	6.32	6.31	7.76	6.62	6.11	6.32	7.47	

Motor dimensions depend on the motor manufacturer and execution. The shown motor dimensions indicate the size for the standard motor

* Option: drain valve (dimensions and other drainage variants on request)

Weight: net-weight without packaging

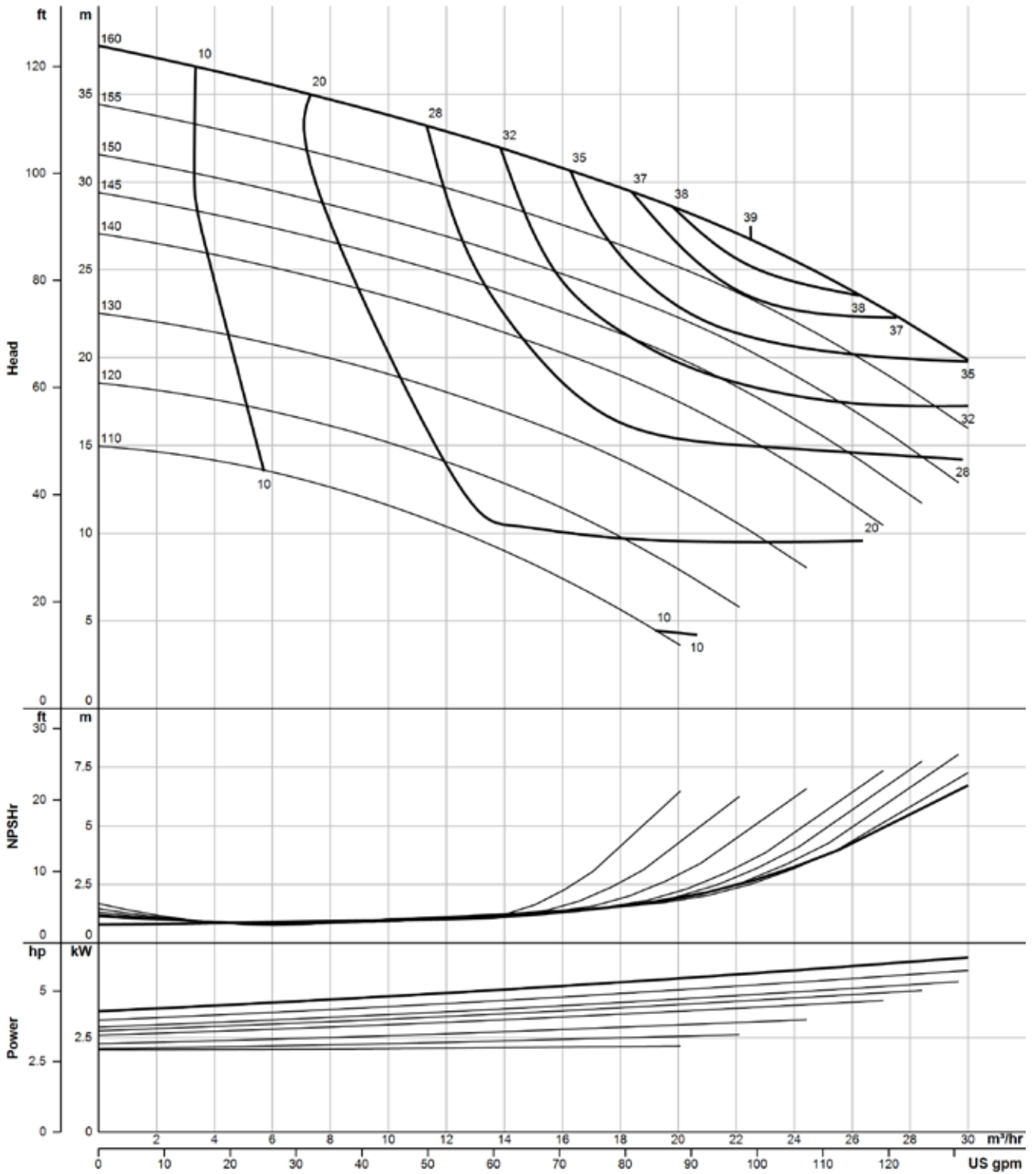

The flow charts are based on water, temperature 59 °F





Technical data of the standard version

Materials	Pump housing: 316L (1.4404), deep-drawn Impeller: 316L (1.4409), precision casting
Connections	Tri-Clamp ASME BPE/DIN 32676
Nominal width of connections	Suction side 2 1/2"; 2", pressure side 2"; 2 1/2"; 3"
Mechanical seal	Single-acting, material C / SIC / EPDM
Static seals	EPDM (FDA, USP Class VI, 3-A)
Motor	Standard motor: NEMA-Motor, 3-phase, 208-230V/460V, C-face with foot, IP55, ISO-Class F, incl. PTC thermostat, premium efficiency
Documentation	Operating instructions, declaration of conformity
Flow rate	Max. 55 m³/h (242 US gpm)
Pump head	Max. 64 m (210 ft)
Housing pressure	Max. 16 bar (232 psi)
Certificates	



Further options see page 74 (Composition of Order Code)

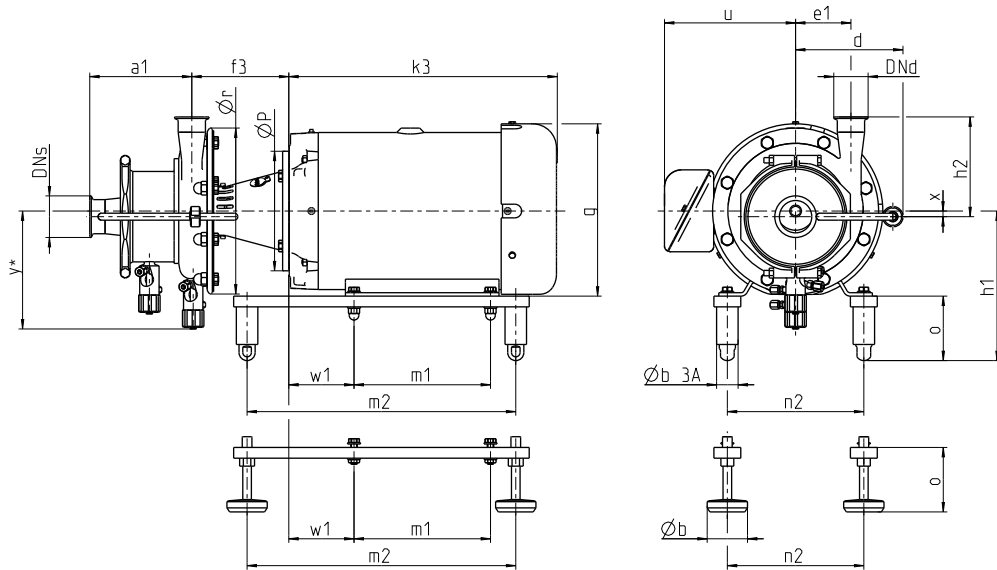

e1 = 4.06 inch
 Ør = 12.17 inch
 x = 0.41 inch
 d = 7.87 inch

Dimensions																	
Frame Size	Power [hp]	k3 [inch]	f3 [inch]	h1 +/- 0.4* [inch]	o +/- 0.4* [inch]	Y* [inch]	ØP [inch]	u [inch]	g [inch]	m1 [inch]	m2 [inch]	n2 [inch]	w1 [inch]	w2 [inch]	Øb _{3A} [inch]	Øb [inch]	Weight [lb]
184TC	5.0	15.16	6.29	9.74	5.24	8.64	8.50	6.70	9.22	5.50	12.20	7.50	3.50	5.57	0.87	1.97	151.00
213TC	7.5	16.70	6.29	10.01	4.76	8.64	8.50	7.97	10.91	7.00	16.14	8.50	4.25	7.81	0.87	1.97	205.00
215TC	10.0	18.27	6.29	10.01	4.76	8.64	8.50	7.97	10.91	7.00	16.14	8.50	4.25	7.81	0.87	1.97	234.00
254TC	15.0	18.56	6.91	10.97	4.72	8.64	8.50	9.45	12.84	10.00	19.69	10.00	4.75	8.82	1.18	2.95	263.00
256TC	20.0	19.35	6.91	10.97	4.72	8.64	8.50	9.45	12.84	10.00	19.69	10.00	4.75	8.82	1.18	2.95	304.00
284TSC	25.0	23.31	6.21	11.72	4.72	8.64	10.50	11.07	14.07	11.00	21.65	11.00	4.75	9.61	1.18	2.95	455.00
286TSC	30.0	23.31	6.21	11.72	4.72	8.64	10.50	11.07	14.07	11.00	21.65	11.00	4.75	9.61	1.18	2.95	506.00

Connections											
DNs 2 1/2" OD. DNd 2" OD	DIN 32676 clamp	Q-line clamp	I-line clamp	H-line clamp	VARIVENT® flange	ANSI 16.4 flange	DIN 11851 thread	SMS thread	ACME bevel thread	NPT thread	
a1	7.47	7.29	7.51	7.35	7.33	9.10	7.92	7.29	7.48	8.50	
h2	7.31	7.00	7.22	7.19	7.17	8.69	7.57	6.98	7.32	8.34	

Motor dimensions depend on the motor manufacturer and execution. The shown motor dimensions indicate the size for the standard motor

* Option: drain valve (dimensions and other drainage variants on request)

Weight: net-weight without packaging

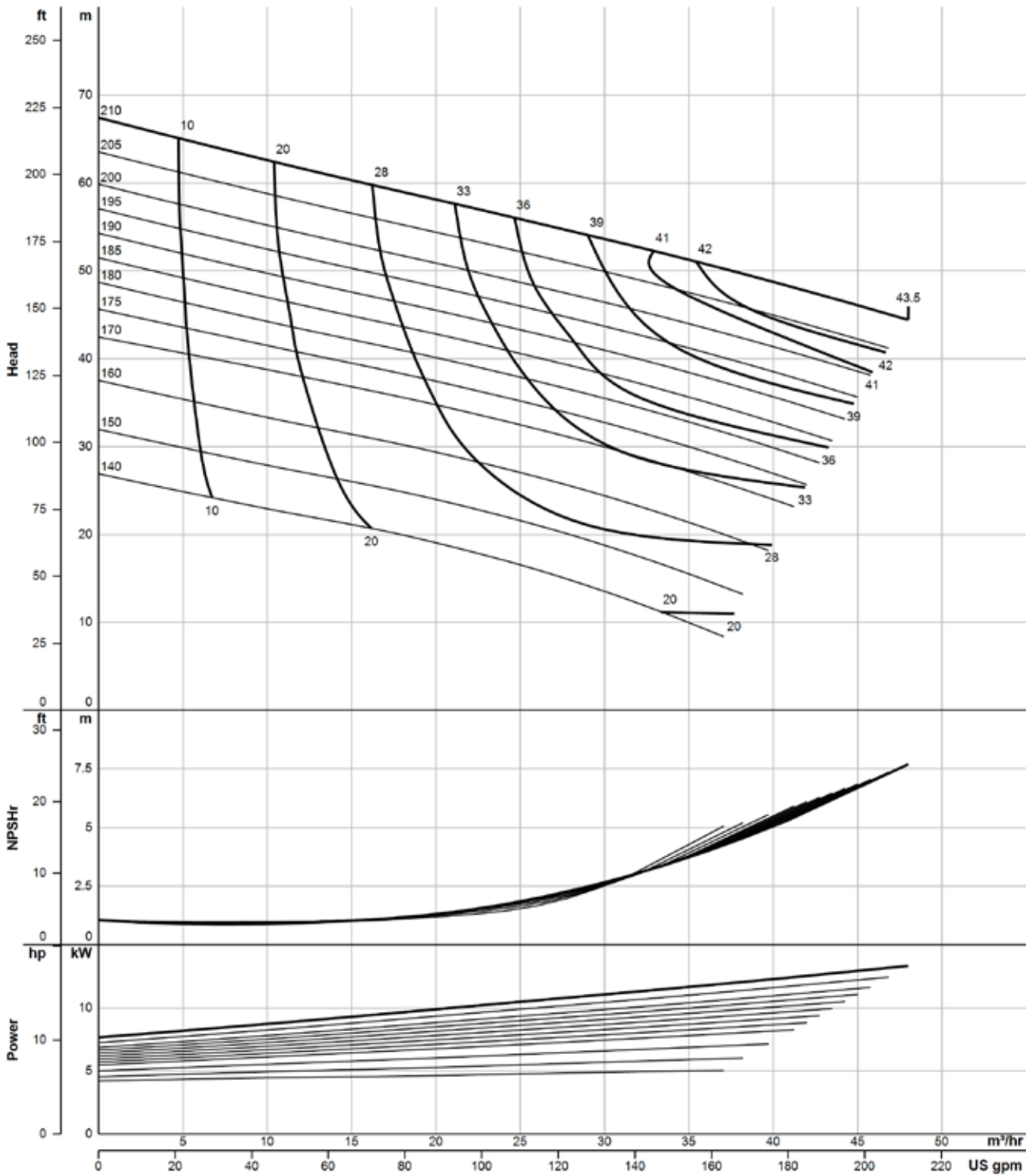

The flow charts are based on water, temperature 59 °F



Technical data of the standard version

Materials	Pump housing: 316L (1.4404), deep-drawn Impeller: 316L (1.4409), precision casting
Connections	Tri-Clamp ASME BPE/DIN 32676
Nominal width of connections	Suction side 3"; 2 1/2", pressure side 2"; 2 1/2"; 3"
Mechanical seal	Single-acting, material C / SIC / EPDM
Static seals	EPDM (FDA, USP Class VI, 3-A)
Motor	Standard motor: NEMA-Motor, 3-phase, 208-230V/460V, C-face with foot, IP55, ISO-Class F, incl. PTC thermostat, premium efficiency
Documentation	Operating instructions, declaration of conformity
Flow rate	Max. 90 m³/h (396 US gpm)
Pump head	Max. 50 m (164 ft)
Housing pressure	Max. 16 bar (232 psi)
Certificates	



Further options see page 74 (Composition of Order Code)

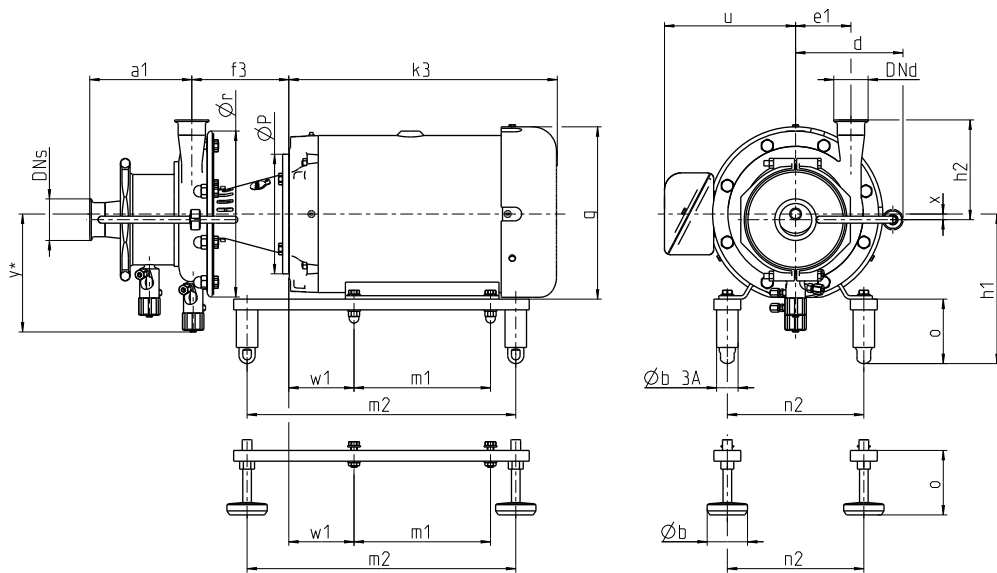

e1 = 4.49 inch
 Ør = 17.01 inch
 x = 0.49 inch
 d = 8.74 inch

Dimensions

Frame Size	Power [hp]	k3 [inch]	f3 [inch]	h1 +/- 0.4* [inch]	o +/- 0.4* [inch]	Y* [inch]	ØP [inch]	u [inch]	g [inch]	m1 [inch]	m2 [inch]	n2 [inch]	w1 [inch]	w2 [inch]	Øb _{3A} [inch]	Øb [inch]	Weight [lb]
215TC	10.0	18.27	6.12	10.01	4.76	9.23	8.50	7.97	10.91	7.00	16.14	8.50	4.25	7.81	0.87	1.97	336.00
254TC	15.0	18.56	6.74	10.97	4.72	9.23	8.50	9.45	12.84	10.00	19.69	10.00	4.75	8.82	1.18	2.95	328.00
256TC	20.0	19.35	6.74	10.97	4.72	9.23	8.50	9.45	12.84	10.00	19.69	10.00	4.75	8.82	1.18	2.95	378.00
284TSC	25.0	23.31	6.04	11.72	4.72	9.23	10.50	11.07	14.07	11.00	21.65	11.00	4.75	9.61	1.18	2.95	537.00
286TSC	30.0	23.31	6.04	11.72	4.72	9.23	10.50	11.07	14.07	11.00	21.65	11.00	4.75	9.61	1.18	2.95	647.00
324TSC	40.0	25.87	6.52	12.92	4.92	9.23	12.50	12.58	15.95	12.00	22.83	12.50	5.25	9.61	1.18	3.94	636.00

Connections

DNs 3" OD. DNd 2 1/2" OD	DIN 32676 clamp	Q-line clamp	I-line clamp	H-line clamp	VARIVENT® flange	ANSI 16.4 flange	DIN 11851 thread	SMS thread	ACME bevel thread	NPT thread
a1	9.39	9.21	9.49	9.27	9.25	11.02	9.84	9.21	9.40	10.42
h2	10.32	10.14	10.36	10.20	10.19	11.95	10.78	10.15	10.33	11.35

Motor dimensions depend on the motor manufacturer and execution. The shown motor dimensions indicate the size for the standard motor

* Option: drain valve (dimensions and other drainage variants on request)

Weight: net-weight without packaging

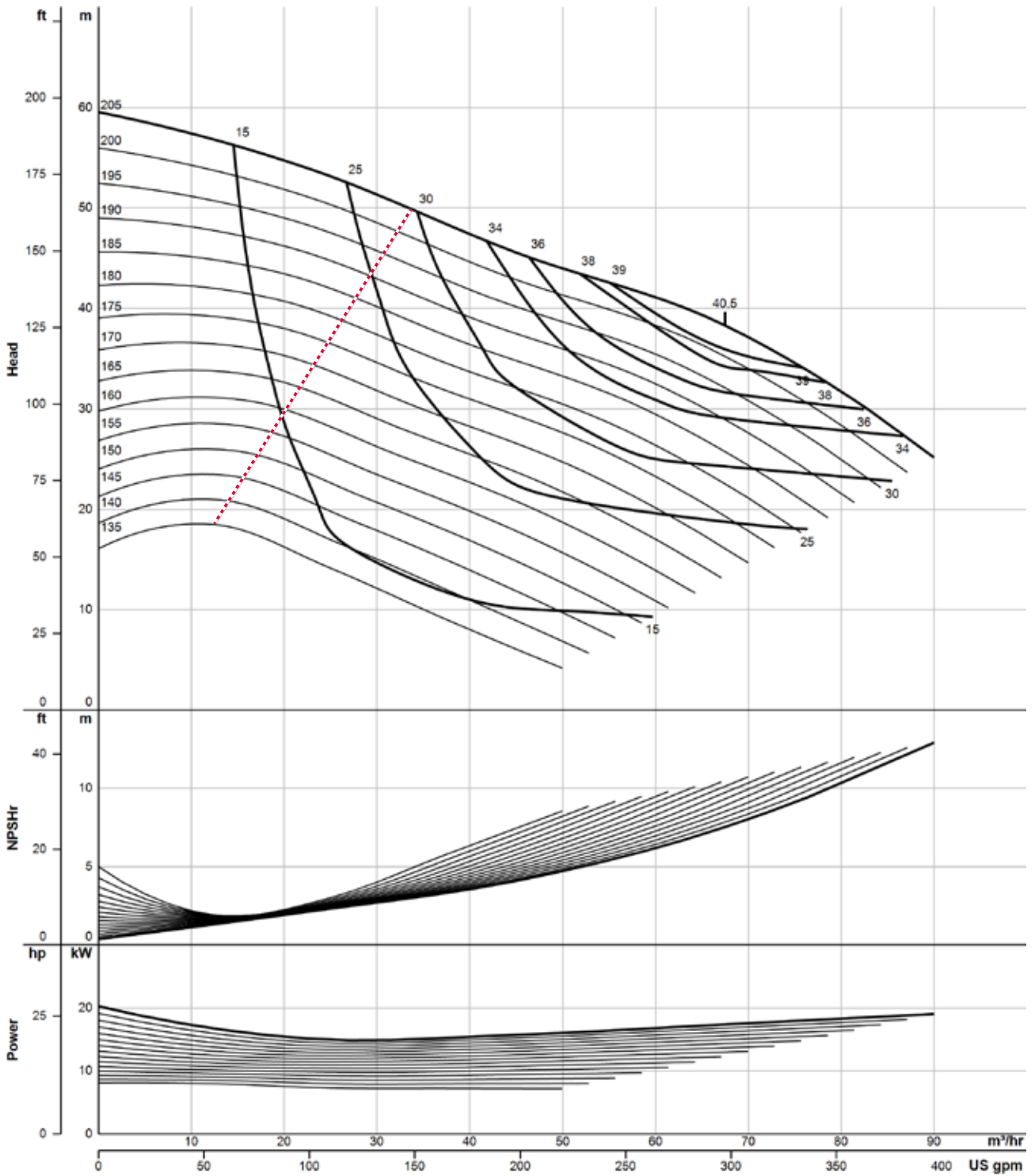

... Lowest allowable duty points
The flow charts are based on water, temperature 59 °F





Technical data of the standard version

Materials	Pump housing: 316L (1.4404), deep-drawn Impeller: 316L (1.4409), precision casting
Connections	Tri-Clamp ASME BPE/DIN 32676
Nominal width of connections	Suction side 3"; 2 1/2", pressure side 2"; 2 1/2"; 3"
Mechanical seal	Single-acting, material C / SIC / EPDM
Static seals	EPDM (FDA, USP Class VI, 3-A)
Motor	Standard motor: NEMA-Motor, 3-phase, 208-230V/460V, C-face with foot, IP55, ISO-Class F, incl. PTC thermostat, premium efficiency
Documentation	Operating instructions, declaration of conformity
Flow rate	Max. 112 m³/h (493 US gpm)
Pump head	Max. 86 m (282 ft)
Housing pressure	Max. 16 bar (232 psi)
Certificates	



Further options see page 74 (Composition of Order Code)

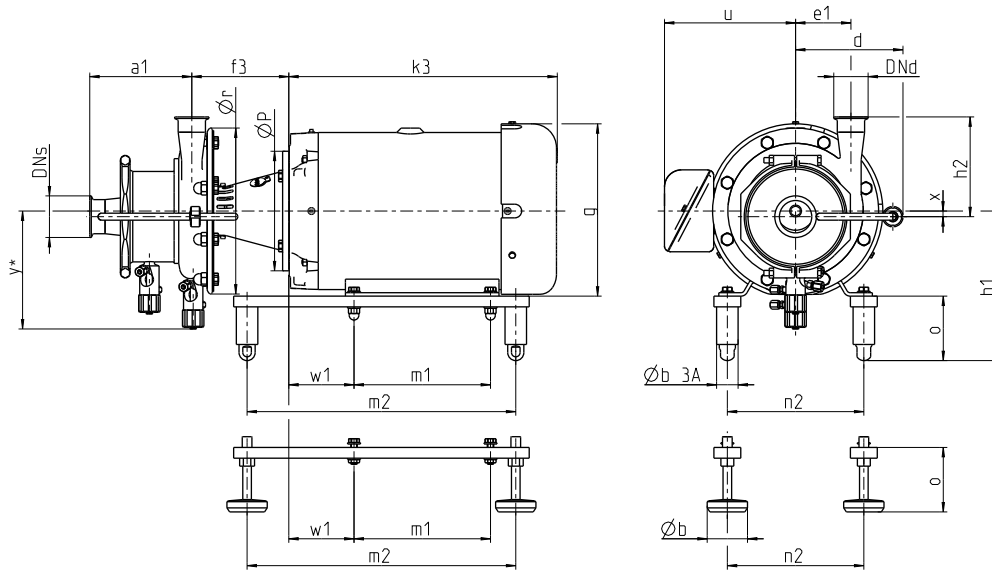

e1 = 4.49 inch
Ør = 17.01 inch
x = 0.49 inch
d = 8.74 inch

Dimensions																	
Frame Size	Power [hp]	k3 [inch]	f3 [inch]	h1 +/- 0.4* [inch]	o +/- 0.4* [inch]	Y* [inch]	ØP [inch]	u [inch]	g [inch]	m1 [inch]	m2 [inch]	n2 [inch]	w1 [inch]	w2 [inch]	Øb _{3A} [inch]	Øb [inch]	Weight [lb]
256TC	20.0	19.35	7.03	10.97	4.72	9.23	8.50	9.45	12.84	10.00	19.69	10.00	4.75	8.82	1.18	2.95	331.00
284TSC	25.0	23.31	6.34	11.72	4.72	9.23	10.50	11.07	14.07	11.00	21.65	11.00	4.75	9.61	1.18	2.95	477.00
286TSC	30.0	23.31	6.34	11.72	4.72	9.23	10.50	11.07	14.07	11.00	21.65	11.00	4.75	9.61	1.18	2.95	508.00
324TSC	40.0	25.87	6.81	12.92	4.92	9.23	12.50	12.58	15.95	12.00	22.83	12.50	5.25	9.61	1.18	3.94	662.00
326TSC	50.0	25.87	6.81	12.92	4.92	9.23	12.50	12.58	15.95	12.00	22.83	12.50	5.25	9.61	1.18	3.94	699.00
364TSC	60.0	28.59	6.81	13.92	4.92	9.23	12.50	16.02	17.96	12.20	23.62	14.00	5.88	9.61	1.18	3.94	940.00

Connections											
DN _s 2" OD. DN _d 2 1/2" OD	DIN 32676 clamp	Q-line clamp	I-line clamp	H-line clamp	VARIVENT® flange	ANSI 16.4 flange	DIN 11851 thread	SMS thread	ACME bevel thread	NPT thread	
a1	9.61	9.42	9.70	9.48	9.47	11.23	10.06	9.43	9.61	10.63	
h2	10.41	10.23	10.45	10.29	10.28	12.04	10.87	10.24	10.42	11.44	

Motor dimensions depend on the motor manufacturer and execution. The shown motor dimensions indicate the size for the standard motor
 * Option: drain valve (dimensions and other drainage variants on request)
 Weight: net-weight without packaging

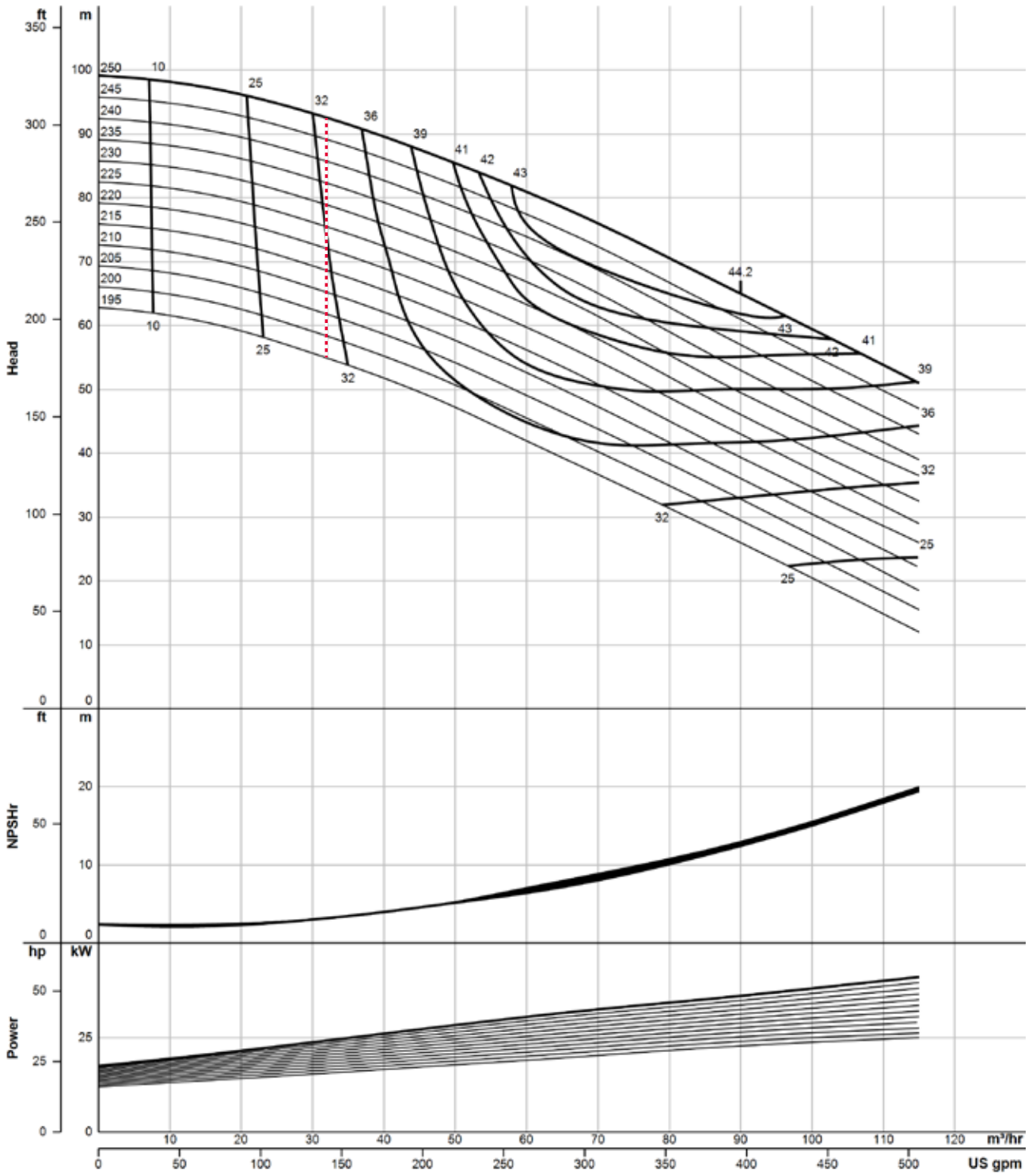

... Lowest allowable duty points
The flow charts are based on water, temperature 59 °F



**GEA Hilge TPS
2-pole
60 Hz**

GEA Hilge TPS 2030

GEA Hilge TPS 3050

GEA Hilge TPS 8050

GEA Hilge TPS 8080



Technical data of the standard version

Materials	Pump housing: 316L (1.4404), deep-drawn Impeller: 316L (1.4409), precision casting
Connections	Tri-Clamp ASME BPE/DIN 32676
Nominal width of connections	Suction port 2½"; 2", pressure port 1½"; 2"
Mechanical seal	Single-acting, material C / SIC / EPDM
Static seals	EPDM (FDA, USP Class VI, 3-A)
Motor	Standard motor: NEMA-Motor, 3-phase, 208-230V/460V, C-face with foot, IP55, ISO-Class F, incl. PTC thermostat, premium efficiency
Documentation	Operating instructions, declaration of conformity
Flow rate	Max. 36 m³/h (158 US gpm)
Pump head	Max. 52 m (171 ft)
Housing pressure	Max. 16 bar (232 psi)
Certificates	



Further options see page 74 (Composition of Order Code)

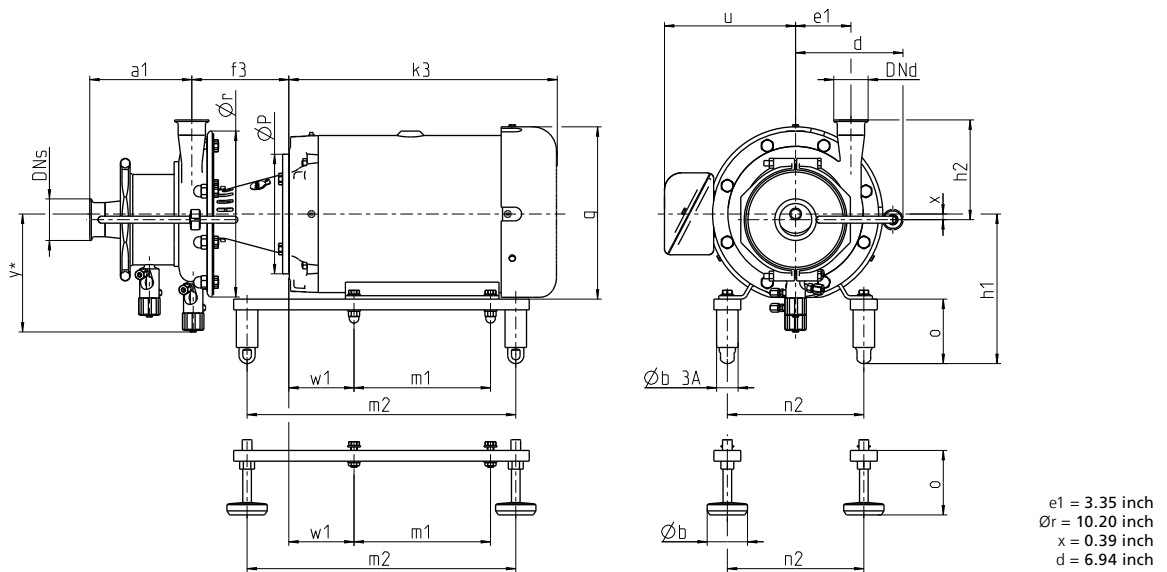

Dimensions																	
Frame Size	Power [hp]	k3 [inch]	f3 [inch]	h1 +/- 0.4* [inch]	o +/- 0.4* [inch]	Y* [inch]	ØP [inch]	u [inch]	g [inch]	m1 [inch]	m2 [inch]	n2 [inch]	w1 [inch]	w2 [inch]	Øb _{3A} [inch]	Øb [inch]	Weight [lb]
143TC	1.5	11.33	4.98	8.74	5.24	7.76	4.50	5.87	7.33	5.00	11.61	5.50	2.75	5.26	0.87	1.97	91.00
145TC	2.0	11.73	4.98	8.74	5.24	0.39	4.50	5.87	7.33	5.00	11.61	5.50	2.75	5.26	0.87	1.97	93.00
182TC	3.0	13.59	6.18	9.74	5.24	0.10	8.50	6.70	9.22	5.50	12.20	7.50	3.50	5.57	0.87	1.97	117.00
184TC	5.0	15.16	6.18	9.74	5.24	3.35	8.50	6.70	9.22	5.50	12.20	7.50	3.50	5.57	0.87	1.97	133.00
213TC	7.5	16.70	6.18	10.01	4.76	6.94	8.50	7.97	10.91	7.00	16.14	8.50	4.25	7.81	0.87	1.97	187.00
215TC	10.0	18.27	6.18	10.01	4.76	5.53	8.50	7.97	10.91	7.00	16.14	8.50	4.25	7.81	0.87	1.97	216.00
254TC	15.0	18.56	6.80	10.97	4.72	4.93	8.50	9.45	12.84	10.00	19.69	10.00	4.75	8.82	1.18	2.95	248.00

Connections											
DNs 2" OD, DNd 1½" OD	DIN 32676 clamp	Q-line clamp	I-line clamp	H-line clamp	VARIVENT® flange	ANSI 16.4 flange	DIN 11851 thread	SMS thread	ACME bevel thread	NPT thread	
a1	6.65	6.47	6.69	6.53	6.52	8.28	7.11	6.48	6.66	7.68	
h2	6.44	5.88	6.26	6.32	6.31	7.76	6.62	6.11	6.32	7.47	

Motor dimensions depend on the motor manufacturer and execution. The shown motor dimensions indicate the size for the standard motor
 * Option: drain valve (dimensions and other drainage variants on request)
 Weight: net-weight without packaging

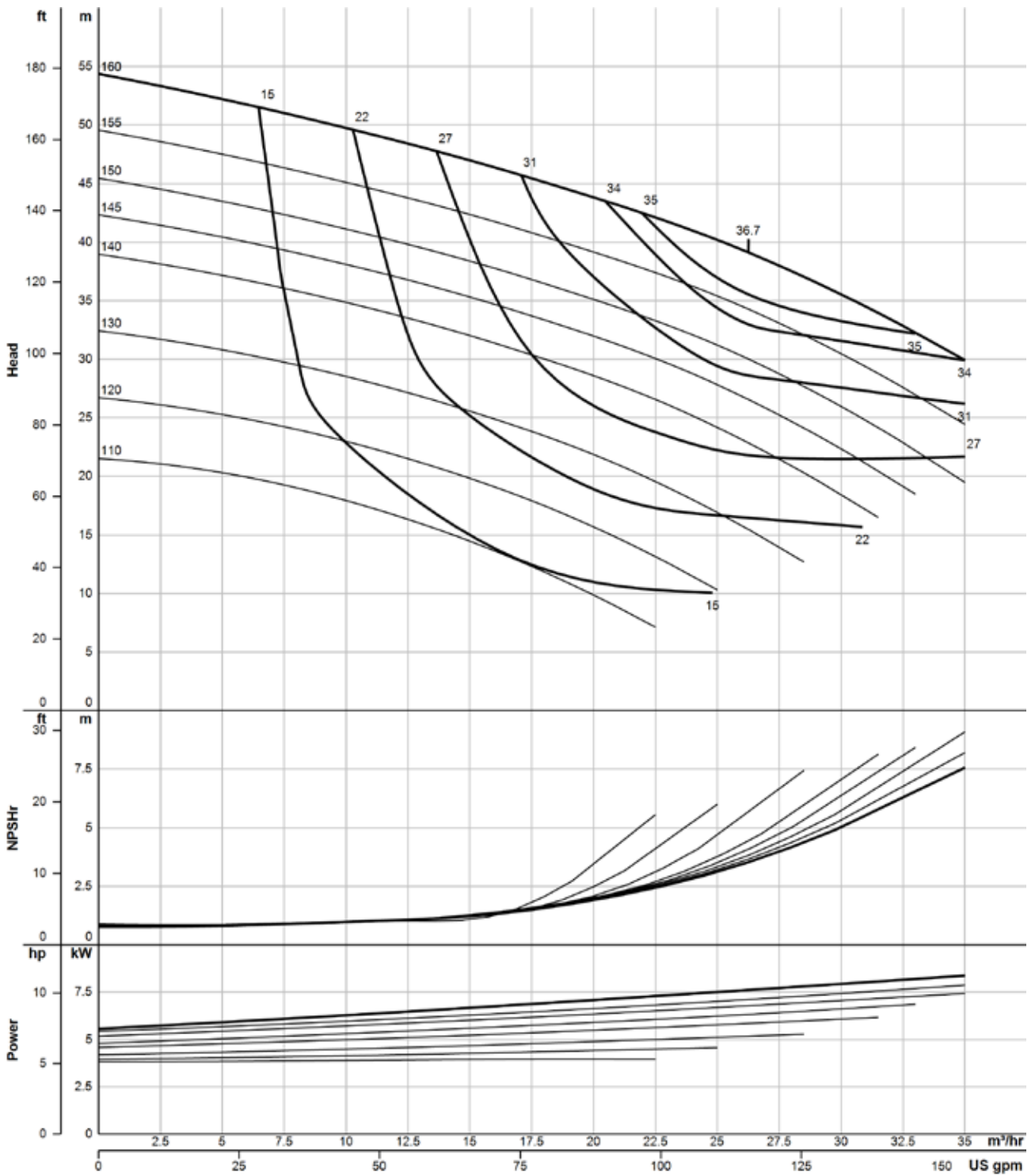

The flow charts are based on water, temperature 59 °F





Technical data of the standard version

Materials	Pump housing: 316L (1.4404), deep-drawn Impeller: 316L (1.4409), precision casting
Connections	Tri-Clamp ASME BPE/DIN 32676
Nominal width of connections	Suction port 2 1/2"; 2", pressure port 2"; 2 1/2"; 3"
Mechanical seal	Single-acting, material C / SIC / EPDM
Static seals	EPDM (FDA, USP Class VI, 3-A)
Motor	Standard motor: NEMA-Motor, 3-phase, 208-230V/460V, C-face with foot, IP55, ISO-Class F, incl. PTC thermostat, premium efficiency
Documentation	Operating instructions, declaration of conformity
Flow rate	Max. 69 m³/h (304 US gpm)
Pump head	Max. 95 m (312 ft)
Housing pressure	Max. 16 bar (232 psi)
Certificates	



Further options see page 74 (Composition of Order Code)

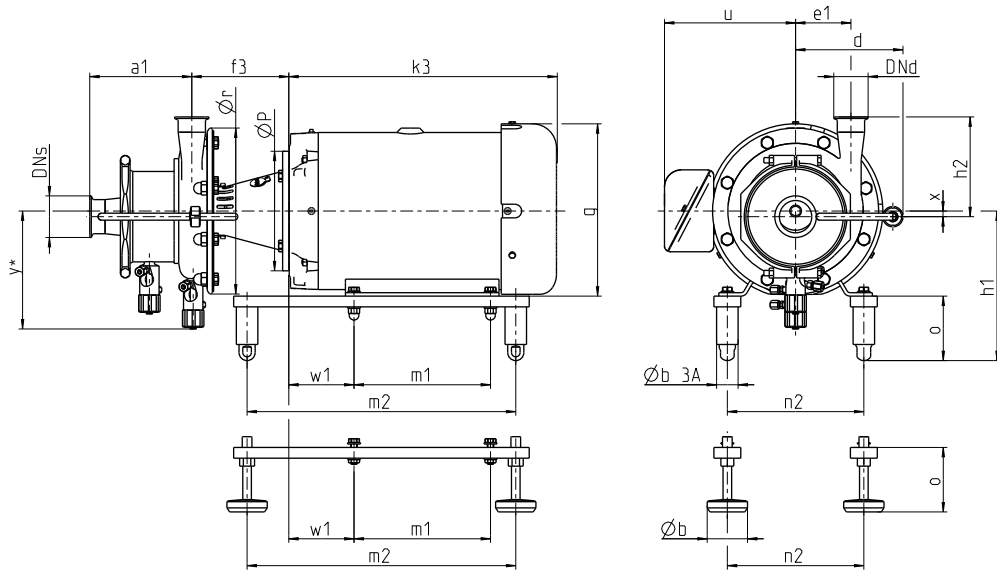

e1 = 4.06 inch
 Ør = 12.17 inch
 x = 0.41 inch
 d = 7.87 inch

Dimensions																	
Frame Size	Power [hp]	k3 [inch]	f3 [inch]	h1 +/- 0.4* [inch]	o +/- 0.4* [inch]	Y* [inch]	ØP [inch]	u [inch]	g [inch]	m1 [inch]	m2 [inch]	n2 [inch]	w1 [inch]	w2 [inch]	Øb _{3A} [inch]	Øb [inch]	Weight [lb]
184TC	5.0	15.16	6.29	9.74	5.24	8.64	8.50	6.70	9.22	5.50	12.20	7.50	3.50	5.57	0.87	1.97	151.00
213TC	7.5	16.70	6.29	10.01	4.76	8.64	8.50	7.97	10.91	7.00	16.14	8.50	4.25	7.81	0.87	1.97	205.00
215TC	10.0	18.27	6.29	10.01	4.76	8.64	8.50	7.97	10.91	7.00	16.14	8.50	4.25	7.81	0.87	1.97	234.00
254TC	15.0	18.56	6.91	10.97	4.72	8.64	8.50	9.45	12.84	10.00	19.69	10.00	4.75	8.82	1.18	2.95	263.00
256TC	20.0	19.35	6.91	10.97	4.72	8.64	8.50	9.45	12.84	10.00	19.69	10.00	4.75	8.82	1.18	2.95	304.00
284TSC	25.0	23.31	6.21	11.72	4.72	8.64	10.50	11.07	14.07	11.00	21.65	11.00	4.75	9.61	1.18	2.95	455.00
286TSC	30.0	23.31	6.21	11.72	4.72	8.64	10.50	11.07	14.07	11.00	21.65	11.00	4.75	9.61	1.18	2.95	506.00

Connections											
DNs 2 1/2" OD. DNd 2" OD	DIN 32676 clamp	Q-line clamp	I-line clamp	H-line clamp	VARIVENT® flange	ANSI 16.4 flange	DIN 11851 thread	SMS thread	ACME bevel thread	NPT thread	
a1	7.47	7.29	7.51	7.35	7.33	9.10	7.92	7.29	7.48	8.50	
h2	7.31	7.00	7.22	7.19	7.17	8.69	7.57	6.98	7.32	8.34	

Motor dimensions depend on the motor manufacturer and execution. The shown motor dimensions indicate the size for the standard motor

* Option: drain valve (dimensions and other drainage variants on request)

Weight: net-weight without packaging

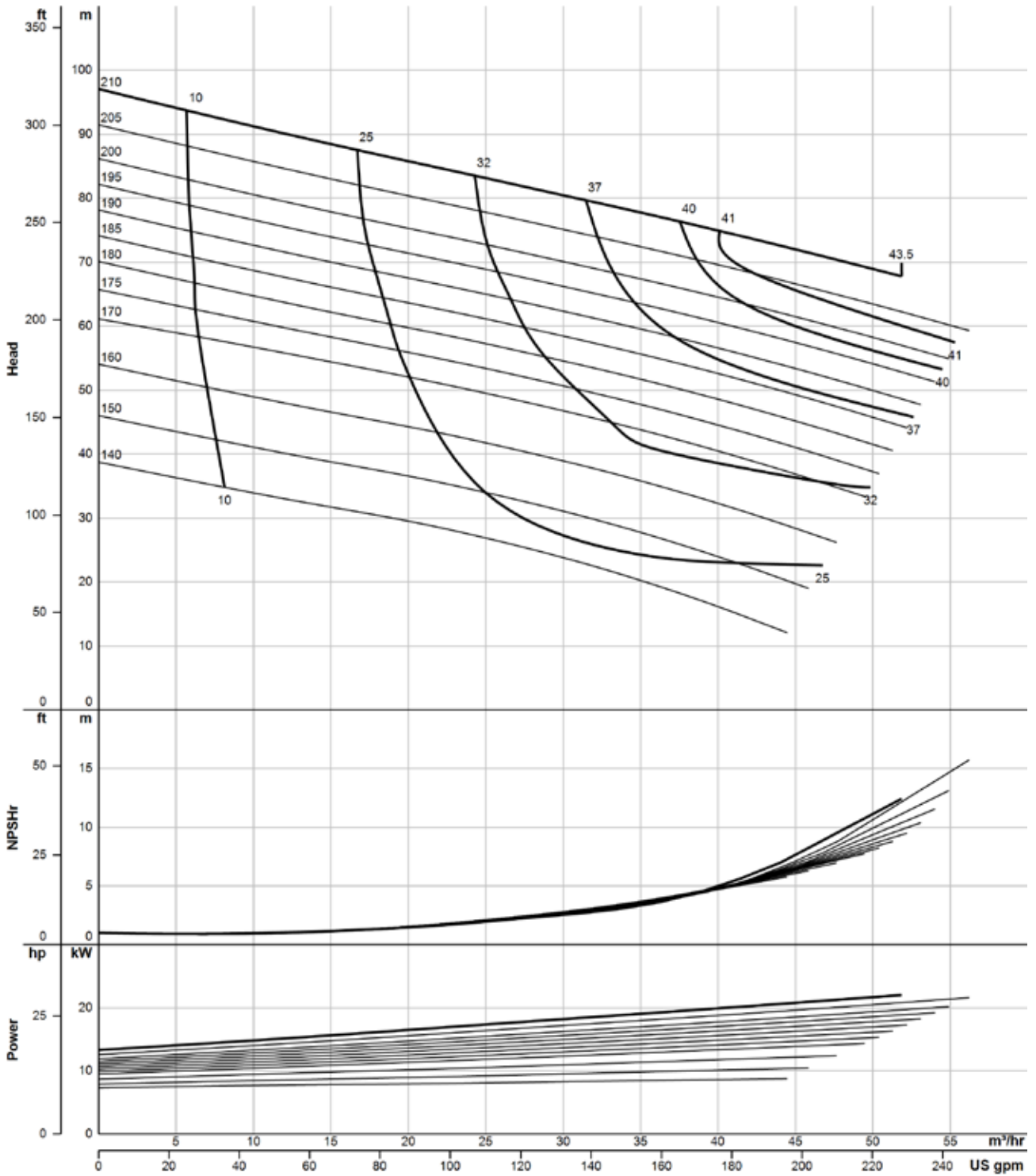

The flow charts are based on water, temperature 59 °F





Technical data of the standard version

Materials	Pump housing: 316L (1.4404), deep-drawn Impeller: 316L (1.4409), precision casting
Connections	Tri-Clamp ASME BPE/DIN 32676
Nominal width of connections	Suction port 3"; 2 1/2", pressure port 2"; 2 1/2"; 3"
Mechanical seal	Single-acting, material C / SIC / EPDM
Static seals	EPDM (FDA, USP Class VI, 3-A)
Motor	Standard motor: NEMA-Motor, 3-phase, 208-230V/460V, C-face with foot, IP55, ISO-Class F, incl. PTC thermostat, premium efficiency
Documentation	Operating instructions, declaration of conformity
Flow rate	Max. 115 m³/h (506 US gpm)
Pump head	Max. 72 m (236 ft)
Housing pressure	Max. 16 bar (232 psi)
Certificates	



Further options see page 74 (Composition of Order Code)

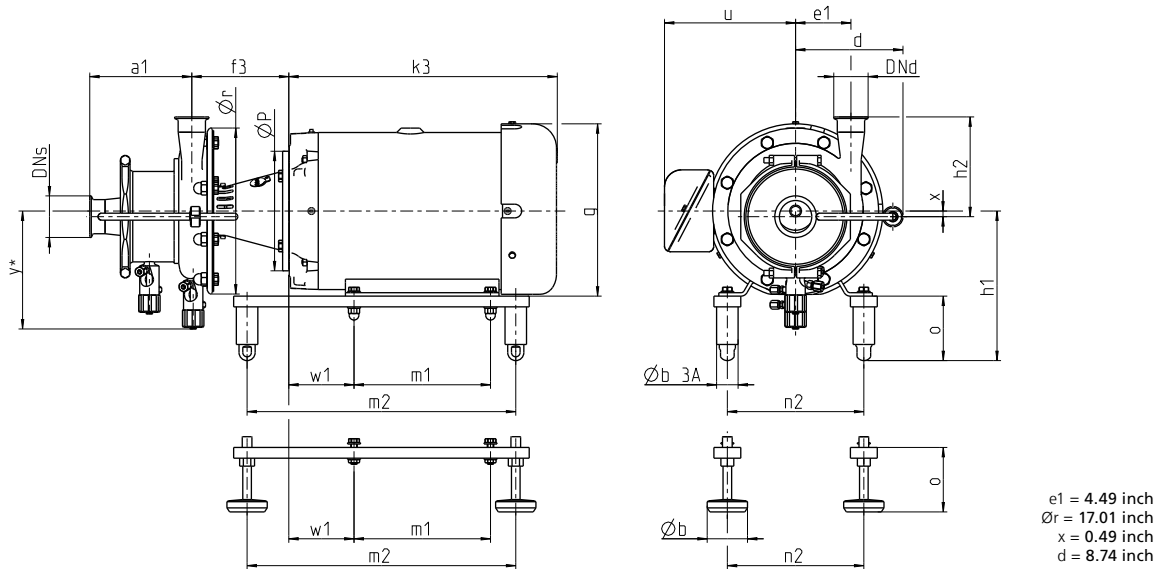

Dimensions																	
Frame Size	Power [hp]	k3 [inch]	f3 [inch]	h1 +/- 0.4* [inch]	o +/- 0.4* [inch]	Y* [inch]	ØP [inch]	u [inch]	g [inch]	m1 [inch]	m2 [inch]	n2 [inch]	w1 [inch]	w2 [inch]	Øb _{3A} [inch]	Øb [inch]	Weight [lb]
256TC	20.0	19.35	7.03	10.97	4.72	9.23	8.50	9.45	12.84	10.00	19.69	10.00	4.75	8.82	0.87	2.95	331.00
284TSC	25.0	23.31	6.34	11.72	4.72	9.23	10.50	11.07	14.07	11.00	21.65	11.00	4.75	9.61	1.18	2.95	477.00
286TSC	30.0	23.31	6.34	11.72	4.72	9.23	10.50	11.07	14.07	11.00	21.65	11.00	4.75	9.61	1.18	2.95	508.00
324TSC	40.0	25.87	6.81	12.92	4.92	9.23	12.50	12.58	15.95	12.00	22.83	12.50	5.25	9.61	1.18	3.94	662.00
326TSC	50.0	25.87	6.81	12.92	4.92	9.23	12.50	12.58	15.95	12.00	22.83	12.50	5.25	9.61	1.18	3.94	699.00
364TSC	60.0	28.59	6.81	13.92	4.92	9.23	12.50	16.02	17.96	12.20	23.62	14.00	5.88	9.61	1.18	3.94	940.00

Connections											
DNs 3" OD. DNd 2 1/2" OD	DIN 32676 clamp	Q-line clamp	I-line clamp	H-line clamp	VARIVENT® flange	ANSI 16.4 flange	DIN 11851 thread	SMS thread	ACME bevel thread	NPT thread	
a1	9.39	9.21	9.49	9.27	9.25	11.02	9.84	9.21	9.40	10.42	
h2	10.32	10.14	10.36	10.20	10.19	11.95	10.78	10.15	10.33	11.35	

Motor dimensions depend on the motor manufacturer and execution. The shown motor dimensions indicate the size for the standard motor
 * Option: drain valve (dimensions and other drainage variants on request)
 Weight: net-weight without packaging

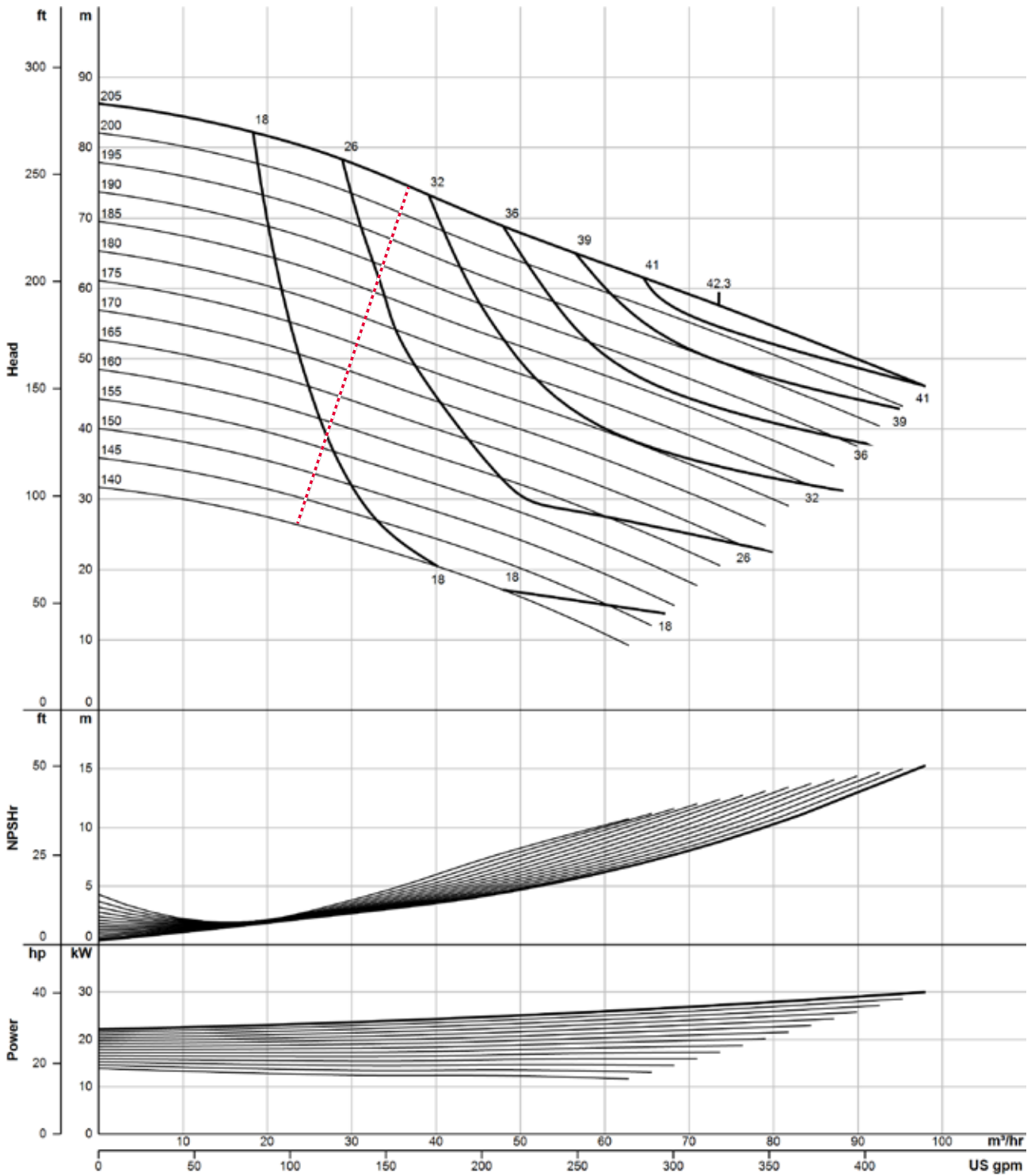

... Lowest allowable duty points
The flow charts are based on water, temperature 59 °F



Technical data of the standard version

Materials	Pump housing: 316L (1.4404), deep-drawn Impeller: 316L (1.4409), precision casting
Connections	Tri-Clamp ASME BPE/DIN 32676
Nominal width of connections	Suction port 3"; 2½", pressure port 2"; 2½"; 3"
Mechanical seal	Single-acting, material C / SIC / EPDM
Static seals	EPDM (FDA, USP Class VI, 3-A)
Motor	Standard motor: NEMA-Motor, 3-phase, 208-230V/460V, C-face with foot, IP55, ISO-Class F, incl. PTC thermostat, premium efficiency
Documentation	Operating instructions, declaration of conformity
Flow rate	Max. 135 m³/h (594 US gpm)
Pump head	Max. 127 m (417 ft)
Housing pressure	Max. 16 bar (232 psi)
Certificates	



Further options see page 74 (Composition of Order Code)

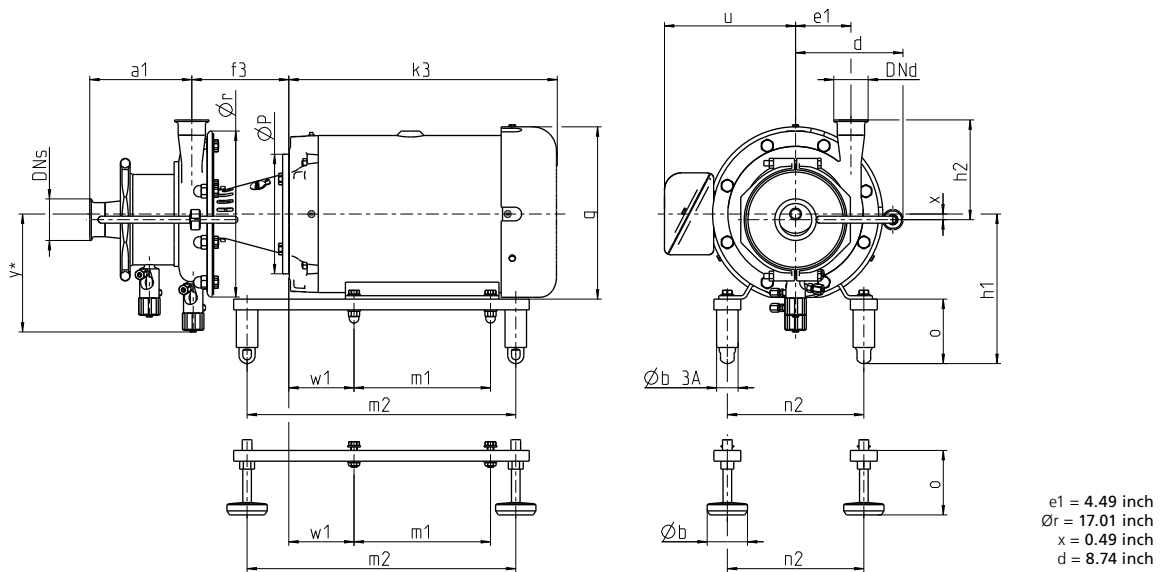

Dimensions																	
Frame Size	Power [hp]	k3 [inch]	f3 [inch]	h1 +/- 0.4* [inch]	o +/- 0.4* [inch]	Y* [inch]	ØP [inch]	u [inch]	g [inch]	m1 [inch]	m2 [inch]	n2 [inch]	w1 [inch]	w2 [inch]	Øb _{3A} [inch]	Øb [inch]	Weight [lb]
256TC	20.0	19.35	7.03	10.97	4.72	9.23	8.50	9.45	12.84	10.00	19.69	10.00	4.75	8.82	1.18	2.95	331.00
284TSC	25.0	23.31	6.34	11.72	4.72	9.23	10.50	11.07	14.07	11.00	21.65	11.00	4.75	9.61	1.18	2.95	477.00
286TSC	30.0	23.31	6.34	11.72	4.72	9.23	10.50	11.07	14.07	11.00	21.65	11.00	4.75	9.61	1.18	2.95	508.00
324TSC	40.0	25.87	6.81	12.92	4.92	9.23	12.50	12.58	15.95	12.00	22.83	12.50	5.25	9.61	1.18	3.94	662.00
326TSC	50.0	25.87	6.81	12.92	4.92	9.23	12.50	12.58	15.95	12.00	22.83	12.50	5.25	9.61	1.18	3.94	699.00
364TSC	60.0	28.59	6.81	13.92	4.92	9.23	12.50	16.02	17.96	12.20	23.62	14.00	5.88	9.61	1.18	3.94	940.00

Connections											
DNs 2" OD. DNd 2 ½" OD	DIN 32676 clamp	Q-line clamp	I-line clamp	H-line clamp	VARIVENT® flange	ANSI 16.4 flange	DIN 11851 thread	SMS thread	ACME bevel thread	NPT thread	
a1	9.61	9.42	9.70	9.48	9.47	11.23	10.06	9.43	9.61	10.63	
h2	10.41	10.23	10.45	10.29	10.28	12.04	10.87	10.24	10.42	11.44	



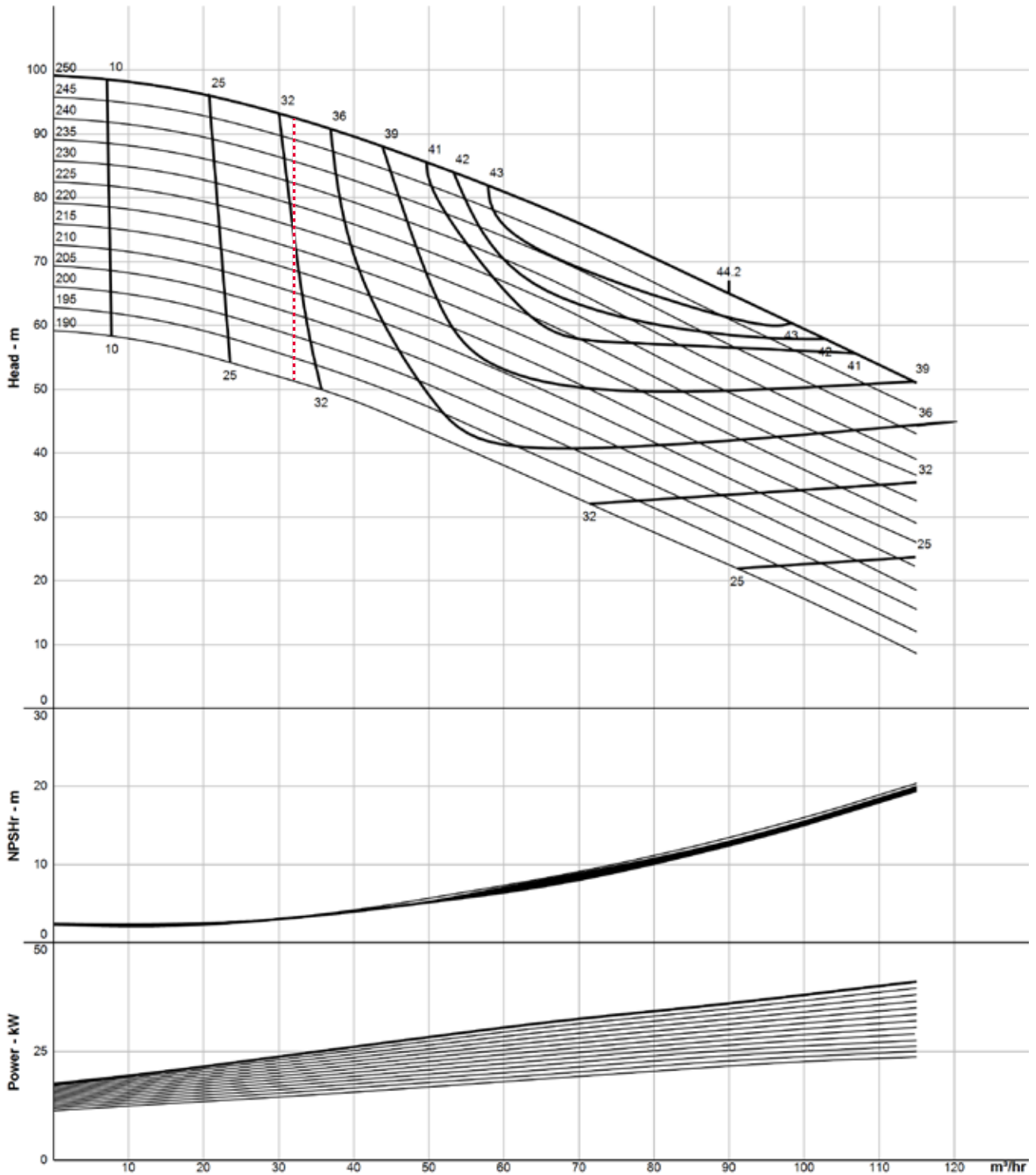









Motor dimensions depend on the motor manufacturer and execution. The shown motor dimensions indicate the size for the standard motor
 * Option: drain valve (dimensions and other drainage variants on request)
 Weight: net-weight without packaging



... Lowest allowable duty points
The flow charts are based on water, temperature 59 °F

Pump code

With 3-A Sanitary Standard 

Position	Composition of order code			
1	Pump type			
	TPS 2030 	TPS 3050 	TPS 8050 	TPS 8080 
2	No. of stages			
	1	1-stage		
3	Version			
	D	3-A	A/B/C	Non 3-A
4	Design			
	K	 Plug-in shaft		
5	Mounting			
	H	M*	B	
	 On 3-A Stainless Steel Adjustable Feet	 On Motor Foot	 On Adjustable Feet	
6	Stainless steel shroud			
	S	With stainless steel shroud		W Without stainless steel shroud
7	Impeller			
	C	 Semi-open		
8	Impeller diameter (mm)			
9	Connection type			
		COA	Tri-clamp	
		QL	Q-line clamp	
		IL	I-line clamp	
		TN	VARIVENT® flange	
		AAB	ANSI-B 16.5 flange	
		ASN	DIN 11864-2 / DIN 11853-2 flange	
		NFK	DIN 11864-2 flange	
		NPT	NPT thread	
		SMG	SMS thread	
		BEV	ACME bevel thread	
		GO	DIN 11851 thread	
		GSK	DIN 11864-1 thread	
		RJT	RJT thread	
		TK	VARIVENT® flange complete	
	ASK	DIN 11864-2 flange complete		
	IG	IDF thread		
	SMK	SMS thread complete		
	GK	DIN 11851 thread complete		
	RJK	RJT thread complete		
	AVK	DIN 11864-1 thread complete		
10	Connection norm			
	D	DIN	O OD	I ISO
11	Diameter suction side			
	DIN	OD		ISO
	1	65–80	2 2½" (2.5)–3" (3)	3 48.3 (48)–114.3 (144)

Motor code

Position	Composition of order code						
1	Motor standard						
	IEC		NEMA		IEC NEMA		
2	No. of poles						
	2	2-pole	4	4-pole	6	6-pole	8
3	Frequency						
	50	50 Hz					60
4	Motor power						
	1 hp to 60 hp						
5	Voltage						
	400/690	400VD/690VY					
	230/400	230VD/400VY					
	220/380	220VD/380VY					
6	Motor design						
	B5	B5	B34	B34	B35	B35	
7	Size						
	143TC to 364TSC						
8	Efficiency class						
	1	IE 1					
	2	IE 2					
	3	IE 3					
	4	IE 4					
	5	IE 5					
	P	NEMA premium efficiency					
S	NEMA super premium efficiency						
9	Protection class						
	55	IP55	56	IP 56	65	IP65	66
10	Motor supplier (alternative motor suppliers on request)						
	S Standard						
11	Options						
	G	General purpose					
	W	Washdown					
	A	Stainless steel washdown					
12	Terminal box						
	L	Left	R	Right	O	Top	U
13	External fan						
	M	With external fan			W	Without external fan	
14	Thermistor						
	M	With thermistor			W	Without thermistor	
15	Frequency converter						
	F	With integrated frequency converter			W	Without integrated frequency converter	
16	ATEX						
	M	With ATEX			W	Without ATEX	

Example of motor dimension order code:

Position	1	2	3	4	5	6	7	8
Code	NEMA	2	60	15 hp	208-230/460	CM	254TC	P
	9	10	11	12	13	14	15	16
	55	S	G	L	W	W	W	W

INQUIRY SHEET · CENTRIFUGAL PUMPS 1/2



GEA Hygienic Pumps

Contact Data

Company: _____

Contact Person: _____ E-Mail: _____

Phone: _____ State: _____

Preferred Range

VARIPUMP SMARTPUMP No requirement

Liquid Data

*Liquid: _____ Solids: No Yes:

*Liquid temperature [°F]: _____ Kind of solids: _____

*Density [lb/ft³]: _____ Size of solids [in]: _____

Viscosity [cPs]: _____ Abrasive: No Yes

Concentration [%]: _____

Operating Conditions

*Duty point 1 Flow [US gpm]: _____ *Head [ft lc]: _____

Duty point 2 Flow [US gpm]: _____ *Head [ft lc]: _____

End-suction pump: Self-priming pump:

Inlet pressure (NPSHa) [ft]: _____ Vacuum at inlet: No Yes

Suction head [ft]: _____ Vacuum, abs. [psi]: _____

System pressure [psi]: _____ Gas content: No < 5 % > 5 %

Cleaning / Sterilization

CIP: No Yes: SIP: No Yes:

CIP Temperature [°F]: _____ SIP Temperature [°F]: _____

CIP Flow [US gpm]: _____ SIP Duration [min]: _____

CIP Head [ft]: _____

Pump execution

*Connection Type ASME

Tri Clamp (DIN 32676) ANSI Flange

Other: _____

Connection Size

DN_i/DN_o:

Drain port

No

Yes: _____

Execution and Design

Bloc version: Pump with stub shaft and motor Combi foot Vertical

Adapta bloc version: Pump with bearing bracket and standard motor On Trolley Vertical with stainless steel stand

With stainless steel shroud Motor foot

3-A Stainless Steel Adjustable Feet Horizontal

* Fields marked with an asterisk are mandatory for a pump selection

INQUIRY SHEET · CENTRIFUGAL PUMPS 2/2



GEA Hygienic Pumps

Surface Roughness

- Not specified
- $R_a \leq 125 \mu\text{in}$ (3.2 μm)
- $R_a \leq 32 \mu\text{in}$ (0.8 μm)
- $R_a \leq 16 \mu\text{in}$ (0.4 μm)

Ferrite Content

- Not specified
- $F_e < 1\%$

Shaft Seal

- Single mechanical seal
- Flushed mechanical seal

Material Shaft Seal

- Carbon/Stainless Steel
- SiC/SiC
- Carbon/SiC
- other: _____

Elastomer

- EPDM
- FKM (Viton)
- other: _____

Motor Data

Supply voltage:

- 3~ 480V/60 Hz
- 3~ 208-230/460V/60 Hz
- 3~ 230V/60 Hz
- 3~ 575V/60 Hz
- other: _____

Motor speed [1/min]: _____

Thermistors: No Yes

Variable speed drive No Yes:

- External frequency converter (not on motor)
- Integrated frequency converter (on motor)

Explosion atmosphere No Yes

EXP Motor No Yes:

Temperature class: _____
 Ambient Temperature [°F]: _____
 Class: _____















Division: _____
 Group: _____

Certificates/Documentation

- 3-A Sanitary Standard
- Inspection certificate 3.1 acc. to DIN EN 10204
- Test report 2.2 acc. to DIN EN 10204
- EHEDG
- UL
- Further certificates and documentation: _____
- FDA declaration of conformity
- Surface roughness test report
- Delta ferrite test report
- CSA
- cURus/cULus

Further Information

* Fields marked with an asterisk are mandatory for a pump selection

2.1		Works certificate according to DIN EN 10204: Declaration of the compliance with the order. This certificate is issued by the manufacturer.
2.2		Test report according to DIN EN 10204: Declaration of the compliance with the order under specification of the results of non-specific tests. This certificate is issued by the manufacturer.
3.1		Inspection certificate 3.1 according to DIN EN 10204: Declaration of the compliance with the order under specification of the results of specific tests. This certificate is issued by an authority which is independent of manufacturing and is validated by the manufacturers authorized inspection representative.
3-A		3-A Sanitary Standards, Inc. (3-A SSI) is an independent, non-profit corporation dedicated to advancing hygienic equipment design for the food, beverage, and pharmaceutical industries.
AS-i		Actuator Sensor interface. BUS system for the lowest field level.
ASME-BPE		Standard of the ASME's – bioprocessing equipment association
ATEX		Atmosphères Explosibles. ATEX comprises the directives of the European Union in the area of explosion protection. For one thing, this is the ATEX equipment directive 94/9/EC, for another, the ATEX workplace directive 1999/92/EC.
cCSAus		Test of a product by CSA according to applicable safety standards in Canada and the USA.
CE		Conformité Européenne. By affixing the CE mark, the manufacturer confirms that the product complies with the European directives applicable to the specific product.
CSA		Canadian Standards Association. A non-governmental Canadian organization which issues standards as well as checking and certifying the safety of products. It is now globally active.
cULus		Test of a product by UL according to applicable safety standards in Canada and the USA.
DIN EN ISO 9001:2015		This norm is the basis for a multitude of varied organizations in different industries worldwide for quality assurance and quality management. It is the most widespread standards of ISO (International Organisation for Standardization).
EAC		Euroasion conformity. The symbol is used similar to the European CE mark. The manufacturer or supplier confirms that the machine has passed all necessary compliance procedures in one of the Member States of the customs union.
EG 1935/2004		Materials in contact with the product used in pumps from GEA Hilge are in accordance with EC regulation 1935/2004. This defines a general framework for materials and objects intended to come into contact with foodstuffs.
EHEDG		European Hygienic Engineering & Design Group. European supervisory authority for foodstuffs and pharmaceuticals. This authority issues approvals and certificates for products and materials that are used in the foodstuffs and pharmaceuticals industries.
FDA		Food and Drug Administration. US supervisory authority for foodstuffs and pharmaceuticals. This authority issues approvals and certificates for products and materials that are used in the foodstuffs and pharmaceuticals industries.
UL		Underwriters Laboratories. An organization founded in the USA for checking and certifying products and their safety.
USP Class VI		The United States Pharmacopeial Convention (USP) is a scientific nonprofit organization that sets standards to help protecting public health. Class VI administer tests and impacts of material and their substances on animal and human tissues.

Abbreviation	Explanation
°C	Degrees Celsius, unit of measurement for temperature
°F	Degrees Fahrenheit, unit of measurement for temperature
3D	Three-dimensional
A	Ampere, unit of measurement of current intensity or Output, term used in automation
AC	Alternating Current
ADI free	All elastomer compounds are free of animal-derived ingredients
AISI	American Iron and Steel Institute, association of the American steel industry
ANSI	American National Standards Institute, American body for standardizing industrial processes
approx.	approximately
AS-i	Actuator Sensor interface, standard for fieldbus communication
ASME	American Society of Mechanical Engineers, professional association of mechanical engineers in the USA
ASME-BPE	Standard of the ASME's – bioprocessing equipment association
ATEX	Atmosphères Explosibles, synonymous with the directives of the European Union for potentially explosive areas
bar	Unit of measurement for pressure. All pressure values [bar/psi] refer to positive pressure [bar _g /psi _g], unless specifically stated otherwise.
bar _g	Unit of measurement for pressure relative to atmospheric pressure
CAN	Controller Area Network; asynchronous serial bus system
CE	Conformité Européenne, administrative symbol for the free movement of industrial products
CIP	Cleaning In Place, designates a process for cleaning technical process systems.
CRN	Canadian Registration Number, is issued by a Canadian Jurisdiction and covers pressure vessels, fittings, or pressure piping. It is a necessary authorization allowing these components to be in operation in Canada.
CSA	Canadian Standards Association, a non-governmental Canadian Standardization organization
Cv	The Cv value corresponds to the water flow rate through a valve (in US gal / min) at a pressure differential of 1 PSI and a water temperature of 5 °C to 30 °C. kv = 14,28 Cv (USA).
Cvs	The Cv values of a valve at nominal stroke (100 % opening) is designated the Cvs value.
dB	Decibel, one tenth of a bel, named after Alexander Graham Bell and used for identifying levels and dimensions
DC	Direct Current

Abbreviation	Explanation
DIN	Deutsches Institut für Normung e. V. Standardization organization in the Federal Republic of Germany, DIN = synonym for standards issued by the organization
DIP	Dual Inline Package, design of a switch
DN	Diameter Nominal, DIN nominal width
Device Net	Network system used in the automation industry to interconnect control devices for data exchange
E	Input, term used in automation
EAC	Certification of technical conformity from the customs union of Russia/Belarus/Kazakhstan
Pressure Equipment Directive 97/23/EC	Directive of the European Parliament and the Council Directive for layout and conformity evaluation for pressure equipment and assemblies with a maximum pressure (PS) of more than 0.5 bars.
EG No. 1935/2004	Regulation of the European Parliament which lays down common rules for materials which come, or may come, into contact with food, either directly or indirectly.
EHEDG	European Hygienic Engineering and Design Group. Consortium of equipment manufacturers, food industries, research institutes as well as public health authorities
EN	European standard, rules of the European Committee for Standardization
EPDM	Ethylene propylene diene rubber, acronym acc. to DIN/ISO 1629
Ex	Synonym for ATEX
FDA	Food and Drug Administration, official foodstuffs monitoring in the United States
FEM calculation	Finite Element Method; calculation process for simulating solids
FKM	Fluorinated rubber, acronym acc. to DIN/ISO 1629
GOST	Gosudarstvennyy Standart, Certification of conformity for components according to standards and regulations of the Russian Federation
H	Henry, unit of measurement for inductance
HNBR	Hydrated acrylonitrile butadiene rubber, acronym acc. to DIN/ISO 1629
Hz	Hertz, unit of frequency named after Heinrich Hertz
I	Formula symbol for electrical current
IEC	International Electrotechnical Commission, international standardization organization for electrical and electronic engineering
IP	Ingress Protection/International Protection, index of protection class acc. to IEC 60529
IPS	Iron Pipe Size, American pipe dimension
ISA	International Society of Automation, international US organization of the automation industry

Abbreviation	Explanation
ISO	International Organization for Standardization, international organization that produced international standards, ISO = synonym for standards from the organization
kg	Kilogram, unit of measurement for weight
Kv	The Kv value corresponds to the water flow rate through a valve (in m ³ /h) at a pressure differential of 0.98 bar and a water temperature of 5 °C to 30 °C.
Kvs	The Kv values of a valve at nominal stroke (100 % opening) is designated the Kvs value
L	Conductive
LED	Light-Emitting Diode
mm	Millimeter, unit of measurement for length
M	Metric, system of units based on the meter or Mega, one million times a unit
m ³ /h	Cubic meters per hour, unit of measurement for volumetric flow
max.	Maximum
NAMUR	Standardization working association for measuring and control technology in the chemical industry, synonym for the interface type of the organization, especially for potentially explosive atmospheres
NC	Normally Closed; valve or solenoid valve control which is closed in idle status
NO	Normally Open; valve or solenoid valve control which is open in idle status
NOT-element	Logic element, NOT gate
NPN	Signal transmission against reference potential, current-consuming
NPT	National Pipe Thread, US thread standard for self-sealing pipe fittings
OD	Outside Diameter, pipe dimension
ODVA	Open DeviceNet Vendor Association, global association for network standards
PA 12/L	Polyamide
Pg	Armored thread
PN	Nominal pressure for pipeline systems according to EN 1333, rated pressure in bar at room temperature (20 °C)
PNP	Signal transmission against reference potential, current-supplying
PPO	Polyphenylene oxide, thermoplastic material
PS	Maximum permitted operating pressure at which the components can operate safely at maximum allowable temperature (TS)

Abbreviation	Explanation
psi	Unit of measurement for pressure, pound-force per square inch, 1 psi = 6894.75 Pa. All pressure values [bar/psi] refer to positive pressure [$\text{bar}_g/\text{psi}_g$], unless specifically stated otherwise.
psi_g	Unit of measurement for pressure relative to atmospheric pressure
PV	Solenoid valve
R_a in μm	Average roughness value, describes the roughness of a technical surface
International Protection-Code IP67, IP66, IP69K	Classifies and rates the degree of protection provided against intrusion dust, accidental contact, and water
SES	GEA Tuchenhagen control head for Ex areas, control top system of GEA Tuchenhagen
SET-UP	Self-learning installation, the SET-UP procedure carries out all necessary settings for generating messages during commissioning and maintenance.
SIP	Sterilization in Place, refers to a process for cleaning technical process systems
SMS	Svensk Mjök Standard, Scandinavian pipe dimension
SW	Indicates the size of a tool spanner, "Schlüsselweite"
TA-Luft VDI 2440	If a product is certified according to TA Luft it meets the requirements for proof of high grade performance according to TA Luft of $1.0 \times 10^{-4} \text{ mbar} \times l / (s \times m)$ at service conditions under the VDI guideline 2440. The product will hence be tested for tightness.
TS	Maximum permitted operating temperature
UL	Underwriters Laboratories, a certification organization established in the USA
USP Class VI	The United States Pharmacopeial Convention (USP) is a scientific nonprofit organization that sets standards to help protecting public health. Class VI administer tests and impacts of material and their substances on animal and human tissues.
UV	Ultraviolet, ultraviolet radiation is a wavelength of light
V	Volt, unit of measurement for voltage
VMQ	High-polymer vinyl methyl polysiloxane, silicone rubber, MVQ = synonym
W	Watt, unit of measurement for power
Y	Control air connection for the working cylinder, designation from pneumatic systems
μ	Micro, one millionth of a unit
Ω	Ohm, the unit of electrical resistance named after Georg Simon Ohm



We live our values.

Excellence • Passion • Integrity • Responsibility • GEA-versity

“Engineering for a better world” is the driving and energizing principle connecting GEA’s workforce. As one of the largest systems suppliers, GEA makes an important contribution to a sustainable future with its solutions and services, particularly in the food, beverage and pharmaceutical sectors. Across the globe, GEA’s plants, processes and components contribute significantly to the reduction of CO₂ emissions, plastic use as well as food waste in production.

GEA is listed on the German MDAX and the STOXX® Europe 600 Index and also included in the DAX 50 ESG and MSCI Global Sustainability indexes.

GEA North America
33 McAlister Farm Road
Portland, ME 04103
Toll-Free 866 531 5629
Fax 207 878 7914

GEA Canada
5045 South Service Road, Suite 201
Burlington, Ontario L7L 5Y7
Tel 289 288 5500

gea.com/unitedstates