



Alfa Laval LeviMag® UltraPure

Mixers

Introduction

The Alfa Laval LeviMag® UltraPure is an aseptic magnetic mixer that uses a patented levitating impeller and advanced design to mix down to the last drop and maximize product yield.

Compact, energy-efficient and easy to maintain, it provides dry-running capabilities and efficient mixing at low speeds, which ensures gentle product treatment, as well as at high speeds for high-intensity mixing. This provides greater process flexibility to handle a wide range of fluid types and mixing duties.

Its open design and low-speed rotation during cleaning contribute to no dead zones, effective residue removal and minimize contamination risks from wear particles. All this contributes to fast return on investment and maximum product yield in tanks ranging in size between 8 gallon and 10567 gallon.

It is supplied with Alfa Laval Q-doc, a comprehensive documentation package that provides full transparency of the entire supply chain and helps make the validation process easy.

Applications

Alfa Laval LeviMag UltraPure offers effective mixing for multiple processes, such as those involving serums, vaccines, plasma fractions, bacteria and cell cultures, and APIs, in the biotechnology, pharmaceutical and other industries with demanding sterile or high-purity applications.

Benefits

- Maximum process efficiency, minimal product loss
- Optimal flow with higher efficiency and less energy consumption
- Mixing down to the last drop for maximum yield due to low agitation and dry-running capability
- Optimized Cleaning-in-Place (CIP) due to full drainability
- Minimized downtime due to ease of maintenance

Standard design

The Alfa Laval LeviMag UltraPure consists of a detachable drive unit, levitating impeller unit with radial blades, seals, ceramic bearings and magnetic coupling, weld plate and connections. It is available in five sizes, with mixing speeds ranging from 10 rpm up to 800 rpm.



Working principle

An impeller with radial blades installed inside the tank rotates due to the torque from the magnetic coupling. The rotation of the impeller mixes the fluid inside the tank. The unique design of the Alfa Laval magnetic coupling ensures the levitation of the impeller at all times. This enables dry-running and complete drainability of process fluids from the tank possible. This ensures highly efficient mixing down to the last drop and, subsequently, maximum yield. It also enables the free flow of CIP liquid and steam around all parts of the mixer, thereby ensuring thorough cleaning. Impeller levitation also eliminates axial wear.

Available versions

- Impeller with male/female bearing
- Impeller complete, with drive unit
- Impeller prepared for Speed Sensor
- ATEX version (Cat. II -/2G Ex h IIC T4 -/Gb)
- SS EN 1.4435 (316L) as standard, Special Alloys EN 1.4529 or EN 2.4602 available on request

Drive unit versions

- Painted (fan ventilated)
- Clean room finish, Sealed Surface Conversion Treatment (smooth, closed, none fan ventilated)
- Extended console for insulated tanks

Motor efficiency

- IE4 (standard)
- Premium (CUS for US)

Safety class

- No requirements (IE4, Premium)
- Eex-de IIC T4 (on ATEX version)
- Class I div.I, group D T4

Accessories

- Weld plates
- Speed Sensor
- Inspection & Service tools
- Installation tools

TECHNICAL DATA

Internals

Product Wetted Surface finish:	Ra <14.96 µin Mech. polished and Electropolished (Acc. to ASME BPE SF4)
Working pressure:	-14.5 to 101.5 PSI
Impeller diameters:	3.94, 5.91, 7.87, 9.84 & 11.81 in Standard or prepared for speed sensor
Versions:	Standard or prepared for speed sensor

Weld Plate

Size WP50:	For impeller size 3.93 & 5.91 in
Size WP81:	For impeller size 7.87, 9.84 & 11.8 in

Drive Unit

Motor, IE4 (standard)

Integrated Permanent Magnet Synchron Motor (IPMSM) which has to be operated with a frequency inverter for IE4 motors

The frequency converter (not Alfa Laval supply) must be ordered for the voltage available at the place of operation

Efficiency class:	IE4
Enclosure / Motor protection:	IP66
Configuration:	Blue
Nominal Power:	1.48 hp
Nominal Voltage and frequency (from frequency converter):	Output 217 VAC, connected in delta, 70 Hz, 2100 RPM
Nominal Current:	3.59 A
Configuration:	Clean room, WP50
Nominal Power:	1.01 hp
Nominal Voltage and frequency (from frequency converter):	Output 199 VAC, connected in delta, 70 Hz, 2100 RPM
Nominal Current:	2.53 A
Configuration:	Clean room, WP81
Nominal Power:	1.48 hp
Nominal Voltage and frequency (from frequency converter):	Output 195 VAC, connected in delta, 70 Hz, 2100 RPM
Nominal Current:	3.61 A
Country Code:	All (one type covers all)

Motor, option Premium/CUS

Efficiency class:	Premium
Enclosure / Motor Protection:	IP66
Configuration:	Blue, WP50
Nominal Power:	0.50 hp
Nominal Voltage and frequency (from frequency converter):	Output 265 VAC, connected in delta, 60 Hz
Nominal Current:	1.40 A
Configuration:	Blue, WP81
Nominal Power:	1.01 hp
Nominal Voltage and frequency (from frequency converter):	Output 265 VAC, connected in delta, 60 Hz

Motor, option Premium/CUS

Nominal Current:	2.72 A
Country Code:	US/CA

Motor, option ATEX

Efficiency class:	IE3
Enclosure / Motor Protection:	IP66
Safety class:	II2G Ex de IIC T4
Configuration:	Blue, WP50
Nominal Power:	0.34 hp
Nominal Voltage and frequency (from frequency converter):	Output 230 VAC, connected in delta, 50 Hz
Nominal Current:	1.30 A
Configuration:	Blue, WP81
Nominal Power:	1.01 hp
Nominal Voltage and frequency (from frequency converter):	Output 230 VAC, connected in delta, 50 Hz
Nominal Current:	2.94 A
Country Code:	EU + Not specific

Motor, option LV Explosion Proof Motor

Efficiency class:	Premium
Enclosure / Motor Protection:	IP66
Safety class:	Class1 Div1 Group D
Configuration:	Blue, WP50
Nominal Power:	0.50 hp
Nominal Voltage and frequency (from frequency converter):	Output 208-230 VAC, connected in delta, 60 Hz
Nominal Current:	2.1 – 2.0 A
Configuration:	Blue, WP81
Nominal Power:	1.48 hp
Nominal Voltage and frequency (from frequency converter):	Output 230 VAC, connected in delta, 60 Hz
Nominal Current:	4.4 A
Country Code:	US/CA

Gear

High efficiency helical bevel right angle gearbox	
Lubricant:	Food compatible oil
Maximum mounting angle acc. to horizontal:	0° - 45° (Different angle intervals based on configuration - Note: Motor may not point downwards)
Surface finish drive unit, standard:	Painted Blue RAL 5010
Surface finish drive unit, Clean Room option:	Sealed Surface Conversion Treatment, Smooth Body (no fan)

Console/flange

Standard height or option for extended height for insulated tanks	
Attachment, Size WP50:	Clamp connection
Attachment, Size WP81:	Flange-bolt connection

PHYSICAL DATA**Materials**

Impeller and Weld plate:	EN 1.4435 (316L/UNS31603), Optionally: EN 1.4529 or EN 2.4602
Drive Rotor, shaft and console/flange:	AISI304 (UNS S30400)
Gear motor, Painted:	C2 according to DIN 12944 (NSF/ANSI 51-2009e)
Gear motor, Clean room:	Permanent Bond Surface (nsd tupH) - compl. w. FDA Title 21 CFR 175.300
Male Bearing:	
Female bearing:	Silicium Carbide (EN 12756)
Seals:	FEP/FKM
Gearbox oil:	USDA H1

Temperatures

During product Mixing, media:	Max. 194 °F
During CIP (max. 50 RPM):	Max. 203 °F
During SIP (max. 50 RPM):	Max. 257 °F
During SIP (max. 0 RPM):	Max. 302 °F

Max. speed

Impeller size 100:	800 RPM (81 Hz)
Impeller size 150:	480 RPM (48.5 Hz)
Impeller size 200:	480 RPM (83 Hz)
Impeller size 250:	230 RPM (40 Hz)
Impeller size 300:	200 RPM (34.5 Hz)

Speed sensor

(Accessory, can only be used for impeller configuration “prepared for speed sensor”)

Alfa Laval Magnetic-Inductive Speed Sensor for LeviMag - the Magnetic inductive proximity sensor is actuated by magnetic fields and capable of detecting permanent magnets in the impeller through the non-magnetic tank material.

Technical Data

Electrical design:	NAMUR
Approval:	ATEX category II 1G
	KEMA 02 ATEX 1090X
	SIL2 (Low Demand Mode) acc. to IEC 61508
	PL c acc. to ISO 13849-1 at HFT0
	SIL3 (All Demand Mode) acc. to IEC 61508
	PL e acc. to ISO 13849-1 with redundant configuration HFT1
Connection:	DC 2-wire, nom. 8.2 VDC
Output:	Acc. to DIN EN 60947-5-6 (NAMUR)
Switching frequency:	1 kHz
Current consumption non-actuated:	< 1.2 mA
Current consumption actuated:	< 2.1 mA

Physical data

Materials:	Cable 4 mm, 2 x 0.25 mm ² , Blue, Lif9YYW, PVC, 2 m
------------	--

Wiring Diagram

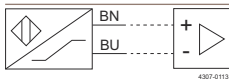

Enclosure:	IP67
------------	------

Documentation:

As standard with UltraPure Q-Doc including:

- Compliance with Regulation (EC) No.: 1935/2004
- Compliance with (Ex/ATEX) directive 2014/34/EU (ATEX option, II -/2G Ex h IIC T4 -/Gb)
- Compliance to the EC Regulation for GMP
- 3.1 Material Certificates acc. to EN10204 (MTR) for all wetted parts
- Compliance to USP Class VI <88> and FEP/FKM seals
- Compliance to FDA CFR 21 (non-metallic parts) for elastomers, ceramics and gear oil
- TSE (Transmissible Spongiform Encephalopathy) / ADI (Animal Derivative Ingredient) Declaration
- Surface finish compliance declaration

Options:

- Surface roughness measurements included
- Weld Log included

Build up:

1. Impeller
2. Seals
3. Female Bearing
4. Male Bearing
5. Weld Plate
6. Clamp ring connection (WP50 only)
7. Flange-Bolt Connection (WP81 only)
8. Drive unit
9. Speed Sensor (Accessory)

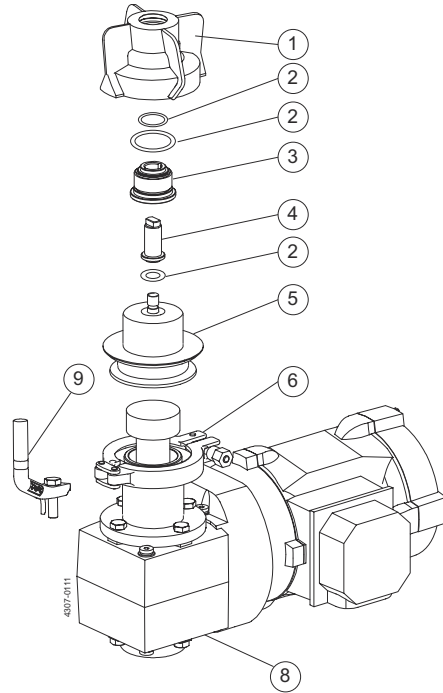

Figure 1. LeviMag WP50

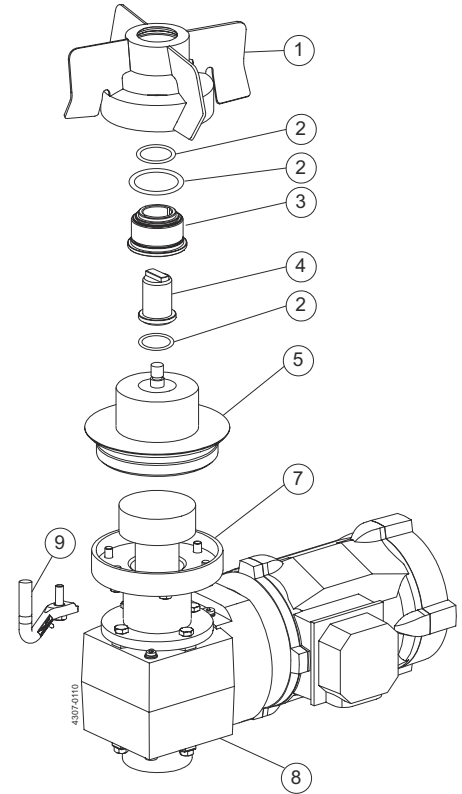

Figure 2. LeviMag WP81

Dimensions: (inch)

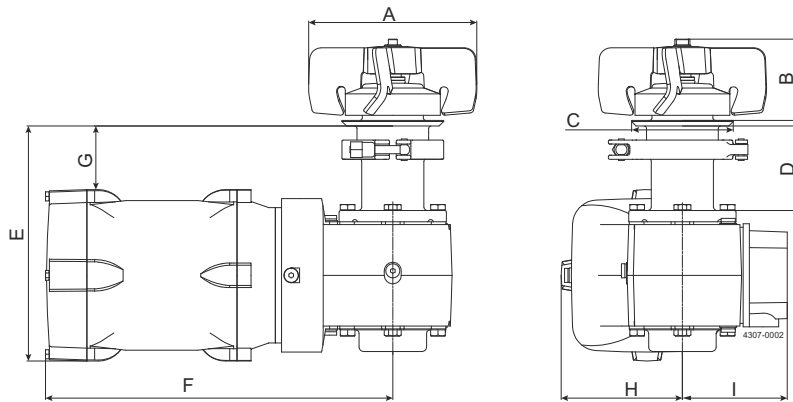

Figure 3. LeviMag WP50

Model	Size WP50 - Ø100 impeller				Size WP50 - Ø150 impeller			
	Standard console	Extended console	Standard console	Extended console	Standard console	Extended console	Standard console	Extended console
Configuration	Height + Painted Gear Motor	Height + Painted Gear Motor	Height + Clean Room Gear Motor	Height + Clean Room Gear Motor	Height + Painted Gear Motor	Height + Painted Gear Motor	Height + Clean Room Gear Motor	Height + Clean Room Gear Motor
A	Ø3.94	Ø3.94	Ø3.94	Ø3.94	Ø5.91	Ø5.91	Ø5.91	Ø5.91
B	2.83	2.83	2.83	2.83	2.83	2.83	2.83	2.83
C	Ø3.50	Ø3.50	Ø3.50	Ø3.50	Ø3.50	Ø3.50	Ø3.50	Ø3.50
D	2.95	4.92	2.95	4.92	2.95	4.92	2.95	4.92
E IE4	8.46	10.43	8.23	10.20	8.46	10.43	8.23	10.20
F IE4	13.39	13.39	12.13	12.13	13.39	13.39	12.13	12.13
G IE4	1.97	3.94	2.24	4.21	1.97	3.94	2.24	4.21

Model	Size WP50 - Ø100 impeller				Size WP50 - Ø150 impeller			
	Standard console Height + Painted Gear Motor	Extended console Height + Painted Gear Motor	Standard console Height + Clean Room Gear Motor	Extended console Height + Clean Room Gear Motor	Standard console Height + Painted Gear Motor	Extended console Height + Painted Gear Motor	Standard console Height + Clean Room Gear Motor	Extended console Height + Clean Room Gear Motor
H IE4	4.49	4.49	4.25	4.25	4.49	4.49	4.25	4.25
I IE4	4.37	4.37	3.66	3.66	4.37	4.37	3.66	3.66
E Premium/CUS	7.95	9.92	-	-	7.95	9.92	-	-
F Premium/CUS	12.51	12.51	-	-	12.51	12.51	-	-
G Premium/CUS	2.48	4.44	-	-	2.48	4.44	-	-
H Premium/CUS	4.13	4.13	-	-	4.13	4.13	-	-
I Premium/CUS	3.70	3.70	-	-	3.70	3.70	-	-
E ATEX	7.95	9.92	-	-	7.95	9.92	-	-
F ATEX	14.68	14.68	-	-	14.68	14.68	-	-
G ATEX	2.44	4.40	-	-	2.44	4.40	-	-
H ATEX	4.13	4.13	-	-	4.13	4.133	-	-
I ATEX	4.68	4.68	-	-	4,68	4,68	-	-
E LV Explosion Proof	8.77	10.74	-	-	8.77	10.74	-	-
F LV Explosion Proof	20.47	20.47	-	-	20.47	20.47	-	-
G LV Explosion Proof	1.77	3.74	-	-	1,77	3,74	-	-
H LV Explosion Proof	4.84	4.84	-	-	4.84	44.21	-	-
I LV Explosion Proof	5.59	5.59	-	-	5.59	5.59	-	-

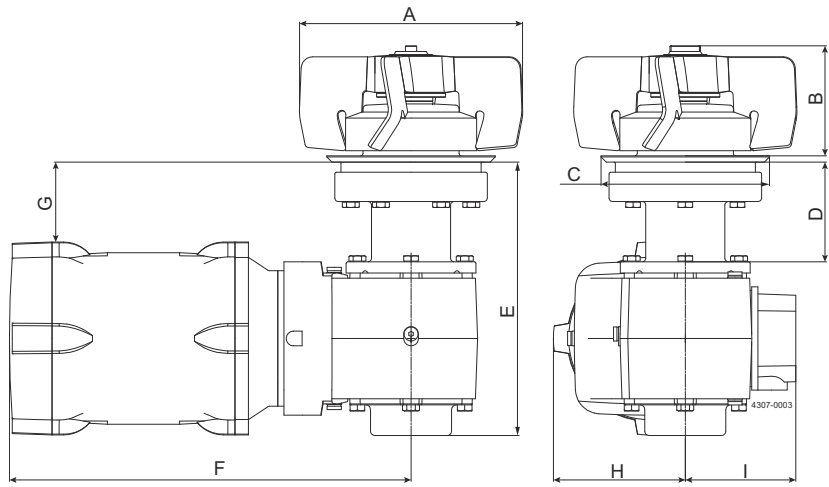
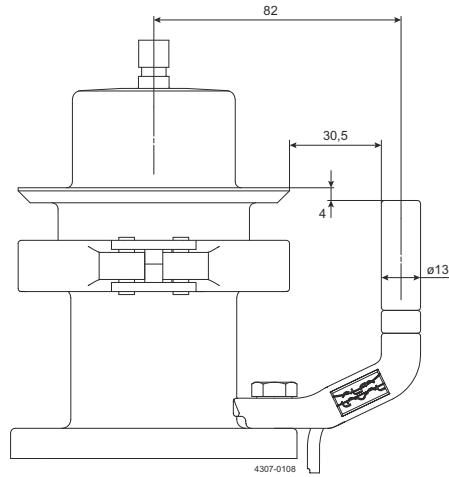
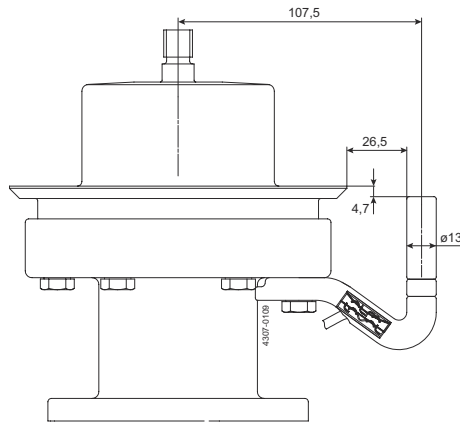

Figure 4. LeviMag WP81

Model	Size WP81 - Ø200 impeller				Size WP81 - Ø250 impeller				Size WP81 - Ø300 impeller			
	Standard console Height + Painted Gear Motor	Extended console Height + Painted Gear Motor	Standard console Height + Clean Room Gear Motor	Extended console Height + Clean Room Gear Motor	Standard console Height + Painted Gear Motor	Extended console Height + Painted Gear Motor	Standard console Height + Clean Room Gear Motor	Extended console Height + Clean Room Gear Motor	Standard console Height + Painted Gear Motor	Extended console Height + Painted Gear Motor	Standard console Height + Clean Room Gear Motor	Extended console Height + Clean Room Gear Motor
A	Ø7.87	Ø7.87	Ø7.87	Ø7.87	Ø9.84	Ø9.84	Ø9.84	Ø9.84	Ø11.81	Ø11.81	Ø11.81	Ø11.81
B	3.86	3.86	3.86	3.86	3.86	3.86	3.86	3.86	3.86	3.86	3.86	3.86
C	Ø5.87	Ø5.87	Ø5.87	Ø5.87	Ø5.87	Ø5.87	Ø5.87	Ø5.87	Ø5.87	Ø5.87	Ø5.87	Ø5.87
D	3.50	5.47	3.50	5.47	3.50	5.47	3.50	5.47	3.50	5.47	3.50	5.47
E IE4	9.57	11.53	9.57	11.54	9.57	11.54	9.57	11.54	9.57	11.54	9.57	11.54
F IE4	13.94	13.94	14.06	14.06	13.94	13.94	14.06	14.06	13.94	13.94	14.06	14.06
G IE4	2.91	4.88	2.76	4.72	2.91	4.88	2.76	4.73	2.91	4.88	2.76	4.73
H IE4	4.49	4.49	4.61	4.61	4.49	4.49	4.61	4.61	4.49	4.49	4.61	4.61
I IE4	4.37	4.37	3.86	3.86	4.37	4.37	3.86	3.86	4.37	4.37	3.86	3.86
E Premium/CUS	9.56	11.53	-	-	9.56	11.53	-	-	9.56	11.53	-	-
F Premium/CUS	13.93	13.93	-	-	13.93	13.93	-	-	13.93	13.93	-	-
G Premium/CUS	3.07	5.03	-	-	3.07	5.03	-	-	3.07	5.03	-	-
H Premium/CUS	4.33	4.33	-	-	4.33	4.33	-	-	4.33	4.33	-	-
I Premium/CUS	4.40	4.40	-	-	4.40	4.40	-	-	4.40	4.40	-	-
E ATEX	11.57	13.54	-	-	11.57	13.54	-	-	11.57	13.54	-	-
F ATEX	16.45	16.45	-	-	16.45	16.45	-	-	16.45	16.45	-	-
G ATEX	3.03	5	-	-	3.03	5	-	-	3.03	5	-	-
H ATEX	4.33	4.33	-	-	4.33	4.33	-	-	4.33	4.33	-	-
I ATEX	5.66	5.66	-	-	5.66	5.66	-	-	5.66	5.66	-	-
E LV Explosion Proof	9.76	11.73	-	-	9.76	11.73	-	-	9.76	11.73	-	-
F LV Explosion Proof	21.02	21.02	-	-	21.02	21.02	-	-	21.02	21.02	-	-
G LV Explosion Proof	2.71	4.68	-	-	2.71	4.68	-	-	2.71	4.68	-	-
H LV Explosion Proof	4.84	4.84	-	-	4.84	4.84	-	-	4.84	4.84	-	-
I LV Explosion Proof	5.59	5.59	-	-	5.59	5.59	-	-	5.59	5.59	-	-



Machine Selection:

LeviMag UltraPure can be sized and configured in Alfa Laval configurator. Selection of size can also be done by use of the below selection charts.

Needed information for selection of size:

- Media Viscosity
- Tank Volume
- Tank diameter and tank bottom shape
- Duty (see below Duty Levels)

Duty Level	Duty	Description
1	Keep media homogenous	Keeping fluids homogenous & low gradient heat transfer
2	Mild blending	Simple blending of miscible fluids & high gradient heat transfer, no specific request to mixing time, create suspension if deposit velocity is below 0.59 inch/s
3	Mixing	Mixing of fluids, relative low mixing time, create suspension if deposit velocity is below 1.18 inch/s
4	Powerful mixing	Dissolving solids, very low mixing time, create suspension if deposit velocity is below 2.36 inch/s

Preconditions for using the selection charts:

- Specific gravity of the media must be less than or equal to 1.1
- Liquid height must be equal to or lower than 2½ times the tank diameter
- If duty involves suspension of particles (see deposit velocity limits in the duty levels), the tank diameter D must be:

$$D \leq \sqrt{\frac{V \cdot 4}{\pi}}$$

where V is the Net Volume

- If preconditions are not fulfilled please contact Alfa Laval Global Technical Support

How to select:

1. Select duty
2. Check preconditions
3. Go to the chart for the chosen duty
4. Read out the point for the requested tank volume (X-axis) and viscosity (Y-axis)
5. Choose the curve to the right from the point
6. If physically possible a larger impeller size can always be chosen - eg. to obtain a gentler product treatment (operating at lower speed)

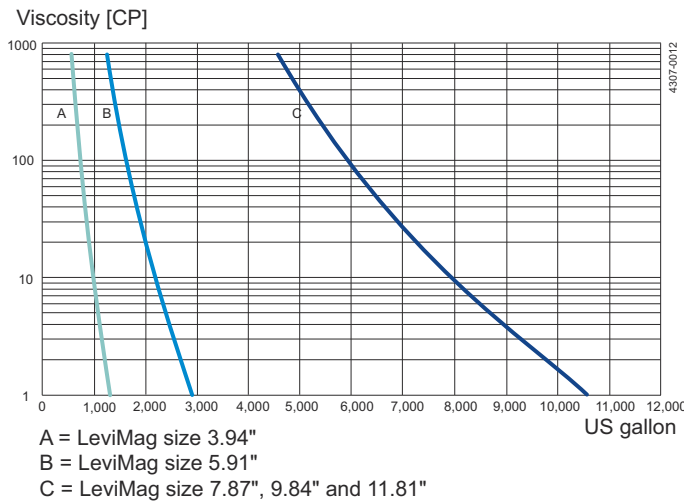
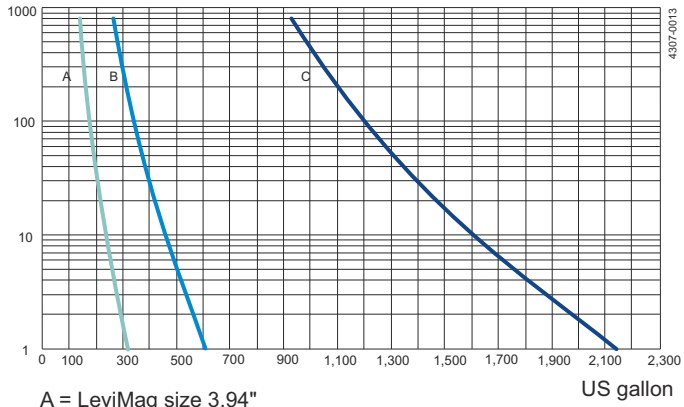

Figure 5. Duty Level 1: Keep media homogenous Volume vs. Viscosity

Viscosity [CP]



A = LeviMag size 3.94"

B = LeviMag size 5.91"

C = LeviMag size 7.87", 9.84" and 11.81"

Figure 6. Duty Level 2: Mild blending Volume vs. Viscosity

Viscosity [CP]

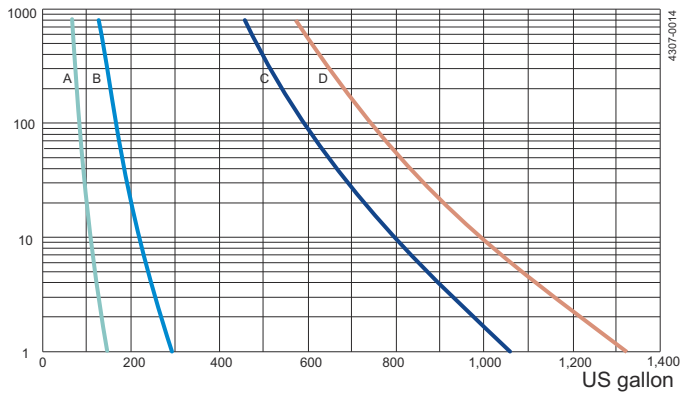

A = LeviMag size 3.94"

B = LeviMag size 5.91"

C = LeviMag size 7.87" & 9.84"

D = LeviMag size 11.81"

Figure 7. Duty Level 3: Mixing Volume vs. Viscosity

Viscosity [CP]

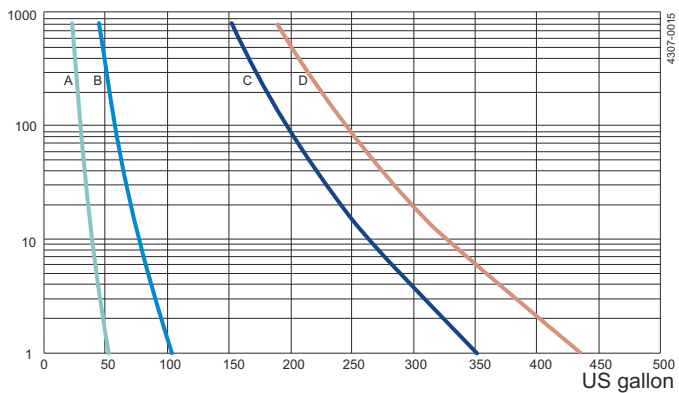

A = LeviMag size 3.94"

B = LeviMag size 5.91"

C = LeviMag size 7.87" & 9.84"

D = LeviMag size 11.81"

Figure 8. Duty Level 4: Powerfull mixing Volume vs. Viscosity

This document and its contents are subject to copyrights and other intellectual property rights owned by Alfa Laval AB (publ) or any of its affiliates (jointly "Alfa Laval"). No part of this document may be copied, re-produced or transmitted in any form or by any means, or for any purpose, without Alfa Laval's prior express written permission. Information and services provided in this document are made as a benefit and service to the user, and no representations or warranties are made about the accuracy or suitability of this information and these services for any purpose. All rights are reserved.

200006333-4-EN-US

© Alfa Laval Corporate

How to contact Alfa Laval

Up-to-date Alfa Laval contact details for all countries are always available on our website at www.alfalaval.com