

Waukesha Cherry-Burrell®

INSTRUCTION MANUAL

Universal 2 Series

Rotary Positive
Displacement Pump

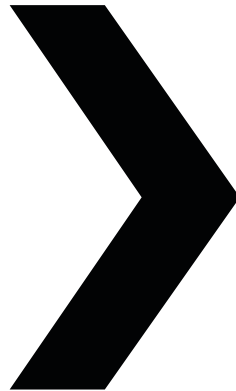

FORM NO.: 95-03015

REVISION: 07/2024

SPXFLOW®

READ AND UNDERSTAND THIS MANUAL PRIOR TO
OPERATING OR SERVICING THIS PRODUCT.

PRODUCT INFORMATION AT YOUR FINGERTIPS

eXpress App

With the new eXpress app, accessing information on a SPX FLOW product is quick and easy.

Simply scan a serial number or QR code and:

- Watch product videos
- Download manuals and drawings
- Receive faster responses to inquiries
- Quick access to where to buy
- Register customer equipment

Scan and Download the eXpress App today

iOS



Android

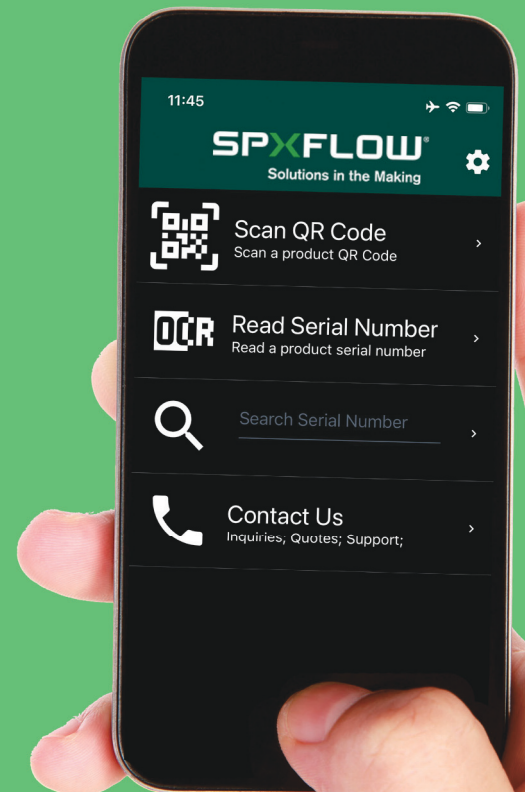
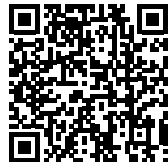

SPX FLOW, Inc.
611 Sugar Creek Road
Delavan, WI 53115 USA

Tel: (800) 252-5200 or (262) 728-1900

Fax: (800) 252-5012 or (262) 728-4904

E-mail: wcb@spxflow.com

Web site: www.spxflow.com

Information contained in this manual is subject to change without notice and does not represent a commitment on the part of SPX FLOW, Inc. No part of this manual may be reproduced or transmitted in any form or by any means, electronic or mechanical, including photocopying and recording, for any purpose, without the express written permission of SPX FLOW, Inc.

Copyright © 2022 SPX FLOW, Inc.
All Rights Reserved.

Revision Date: 07/2024

Publication: 95-03015

Warranty	6
Shipping Damage or Loss	6
Warranty Claim	6
Safety	7
Warnings	8
Replacement Labels	9
Application Instructions	9
Care of Component Materials	10
Stainless Steel Corrosion	10
Alloy 88	10
Elastomer Seal Replacement Following Passivation	10
Introduction	11
Pump Receiving	11
Intended Use	11
Equipment Serial Number	11
Pump Shaft Location	12
Operating Parameters	12
Certifications	15
Factory Remanufacturing Program	15
Qualification Guidelines for Operating Staff	16
Installation	17
Important Safety Information	17
Lifting	17
Install Pump and Drive Unit	18
Install Connections and Piping	19
Install Check Valves	20
Install Isolation Valves	20
Install Relief Valves	21
Inlet Side Strainers and Traps	22
Install Pressure Gauges	22
Seal Flush Connections	23
CIP (Clean-In-Place) Features	24
Check Coupling Alignment	25
Check Angular Alignment	25
Check Parallel Alignment	25
Check Belt and Chain Drive Alignment	26
Check Pump Rotation	26
Operation	27
Pre-Startup Checklist	27
Startup Procedure	27
Shutdown Procedure	27
Emergency Shutdown Procedure	27
Maintenance	28
Important Safety Information	28
Lubrication	29
Maintenance Inspections	30
Annual Maintenance	31
Cleaning	33
Fluid Head Disassembly	34

Gear Case Disassembly	38
Shaft Assembly	40
Gear Case Assembly	43
Fluid Head Assembly	49
Jacketed Cover	55
Triple Lip Seal-Disassembly and Assembly	56
Troubleshooting	62
Parts List	66
006, 014, 015, 018-U2 Pump Parts	66
006, 014, 015, 018-U2 Common Parts	68
030, 034, 040-U2 Common Parts	74
045, 060, 064, 130, 134-U2 Pump Parts	78
045, 060, 064, 130, 134-U2 Common Parts	80
045, 060, 130-U2 Rear Bearing and Spacer	85
180, 184, 220, 224-U2 Pump Parts	86
180, 184, 220, 224-U2 Common Parts	88
210, 213, 214, 320, 323, 324, 370-U2 Pump Parts	92
210, 213, 214, 320, 323, 324, 370-U2 Common Parts	94
210, 213, 214, 320, 323, 324, 370-U2 Common Parts	95
Universal 2 Standard Seals	100
Universal 2 Narrow Face (NF) Seals	103
Universal 2 High-Pressure Barrier (HPB) Seals	104
Triple Lip Seal	105
Seal Kits - 006, 015, 018-U2, 014-U2, 030, 040-U2, 034-U2	106
Seal Kits - 045, 060, 130-U2, 180, 220-U2	107
Seal Kits - 184-U2, 210, 213-U2, 214-U2, 224-U2	108
Seal Kits - 320-U2, 370-U2, 324-U2	109
Triple Lip Seal Kits	110
Shaft & Bearing Assemblies	112
Grease Seals, Bearing Retainers, and Bearing Isolator Kits	113
Universal 2 PD Pump Vented Covers	114
Tru-Fit™ Universal 2 PD Pump	116
Special Tools	118
Long Term Storage	119
Pump Dimensions	120
Pump Shaft Guards	125
ATEX Declaration for Universal 2	126
Nameplates	126
Universal 2 Maintenance Summary Reference Sheet	128
Universal 2 Maintenance Summary Reference Sheet - Copy for optional removal	129

Warranty

LIMITED WARRANTY: Unless otherwise mutually agreed to in writing, (a) SPX FLOW US, LLC (SPX FLOW) goods, auxiliaries and parts thereof are warranted to the Buyer against defective workmanship and material for a period of twelve (12) months from date of installation or eighteen (18) months from date of delivery, whichever expires first, and (b) SPX FLOW services are warranted to Buyer to have been performed in a workman-like manner for a period of ninety (90) days from the date of performance. If the goods or services do not conform to the warranty stated above, then as Buyer's sole remedy, SPX FLOW shall, at SPX FLOW's option, either repair or replace the defective goods or re-perform defective services. If Buyer makes a warranty claim to SPX FLOW and no actual defect is subsequently found, Buyer shall reimburse SPX FLOW for all reasonable costs which SPX FLOW incurs in connection with the alleged defect. Third party goods furnished by SPX FLOW will be repaired or replaced as Buyer's sole remedy, but only to the extent provided in and honored by the original manufacturer's warranty. Unless otherwise agreed to in writing, SPX FLOW shall not be liable for breach of warranty or otherwise in any manner whatsoever for: (i) normal wear and tear; (ii) corrosion, abrasion or erosion; (iii) any good or services which, following delivery or performance by SPX FLOW, has been subjected to accident, abuse, misapplication, improper repair, alteration (including modifications or repairs by Buyer, the end customer or third parties other than SPX FLOW), improper installation or maintenance, neglect, or excessive operating conditions; (iv) defects resulting from Buyer's specifications or designs or those of Buyer's contractors or subcontractors other than SPX FLOW; or (v) defects resulting from the manufacture, distribution, promotion or sale of Buyer's products; (vi) damage resulting from the combination, operation or use with equipment, products, hardware, software, firmware, systems or data not provided by SPX FLOW, if such damage or harm would have been avoided in the absence of such combination, operation or use; or (vii) Buyer's use of the goods in any manner inconsistent with SPX FLOW's written materials regarding the use of such product. In addition, the foregoing warranty shall not include any labor, dismantling, re-installation, transportation or access costs, or other expense associated with the repair or replacement of SPX FLOW goods. THE WARRANTIES CONTAINED HEREIN ARE THE SOLE AND EXCLUSIVE WARRANTIES AVAILABLE TO BUYER AND SPX FLOW HEREBY DISCLAIMS ANY OTHER WARRANTIES, EXPRESS OR IMPLIED, INCLUDING WITHOUT LIMITATION THE IMPLIED WARRANTIES OF MERCHANTABILITY AND FITNESS FOR A PARTICULAR PURPOSE, ANY PERFORMANCE OR PROCESS OUTCOME DESIRED BY THE BUYER AND NOT SPECIFICALLY AGREED TO BY SPX FLOW. THE FOREGOING REPAIR, REPLACEMENT AND REPERFORMANCE OBLIGATIONS STATE SPX FLOW'S ENTIRE AND EXCLUSIVE LIABILITY AND BUYER'S EXCLUSIVE REMEDY FOR ANY CLAIM IN CONNECTION WITH THE SALE AND FURNISHING OF SERVICES, GOODS OR PARTS, THEIR DESIGN, SUITABILITY FOR USE, INSTALLATION OR OPERATIONS.

Shipping Damage or Loss

If equipment is damaged or lost in transit, file a claim at once with the delivering carrier. The carrier has a signed Bill of Lading acknowledging that the shipment has been received from SPX FLOW in good condition. SPX FLOW is not responsible for the collection of claims or replacement of materials due to transit shortage or damages.

Warranty Claim

All warranty claims should initially be directed to the SPX FLOW authorized distributor (Distributor) from whom Buyer purchased the product(s) in question. Warranty claims must have a Returned Material Authorization (RMA) from the Distributor or SPX FLOW or returns will not be accepted. The Distributor and SPX FLOW will assess the product(s) and make any necessary or appropriate repairs or replace the product, as determined by SPX FLOW in its sole discretion, in accordance with the above warranty statement. If it is determined that any necessary repairs for the product(s) are not covered by warranty, Buyer will be contacted prior to the performance of such repairs or the return or destruction of such product(s), as applicable.

Claims for shortages or other errors must be made in writing to SPX FLOW or Distributor, as applicable, within ten (10) days after delivery. This does not include transit shortage or damages. Failure to give such notice shall constitute acceptance and waiver of all such claims by Buyer.

Safety

READ AND UNDERSTAND THIS MANUAL PRIOR TO INSTALLING, OPERATING, OR SERVICING THIS EQUIPMENT

SPX FLOW recommends users of our equipment and designs follow the latest Industrial Safety Standards. At a minimum, these should include the industrial safety requirements established by:

1. Occupational Safety and Health Administration (OSHA)
2. National Fire Protection Association (NFPA)
3. National Electrical Code (NEC)
4. American National Standards Institute (ANSI)

WARNING

Severe injury or death can result from electrical shock, burn, or unintended actuation of equipment. Recommended practice is to disconnect and lockout industrial equipment from power sources, and release stored energy, if present. Refer to the National Fire Protection Association Standard No. NFPA70E, Part II and (as applicable) OSHA rules for Control of Hazardous Energy Sources (Lockout-Tagout) and OSHA Electrical Safety Related Work Practices, including procedural requirements for:

- Lockout-tagout
- Personnel qualifications and training requirements
- When it is not feasible to de-energize and lockout-tagout electrical circuits and equipment before working on or near exposed circuit parts

Before putting SPXFLOW equipment into operation, the operator shall analyze the application for all foreseeable risks, their likelihood to occur and the potential consequences of the identified risks as per ISO 31000 and ISO/IEC 31010 in their actual current version.

Locking and Interlocking Devices: These devices should be checked for proper working condition and capability of performing their intended functions. Make replacements only with the original equipment manufacturer's OEM renewal parts or kits. Adjust or repair in accordance with the manufacturer's instructions.

Periodic Inspection: Equipment should be inspected periodically. Inspection intervals should be based on environmental and operating conditions and adjusted as indicated by experience. At a minimum, an initial inspection within 3 to 4 months after installation is recommended. Inspection of the electrical control systems should meet the recommendations as specified in the National Electrical Manufacturers Association (NEMA) Standard No. ICS 1.3, Preventative Maintenance of Industrial Control and Systems Equipment, for the general guidelines for setting-up a periodic maintenance program.

Replacement Equipment: Use only replacement parts and devices recommended by the manufacturer to maintain the integrity of the equipment. Make sure the parts are properly matched to the equipment series, model, serial number, and revision level of the equipment.

Warnings and cautions are provided in this manual to help avoid serious injury and/or possible damage to equipment:

DANGER

marked with a stop sign.

Immediate hazards which WILL result in severe personal injury or death.

WARNING

marked with a warning triangle.

Hazards or unsafe practices which COULD result in severe personal injury or death.

CAUTION

marked with a warning triangle.

Hazards or unsafe practices which COULD result in minor personal injury or product or property damage.

Warnings

1. Read the instructions before installing the pump and starting it up. Always follow the guidelines for assembly in order to achieve optimum operational reliability.
2. Always check that the specifications of the motor and the motor control unit are correct, particularly in operating environments where there may be a risk of explosion.
3. Pumps should only be installed, disassembled, repaired and assembled by personnel trained in servicing pumps.
4. Always ensure that all electrical installation is carried out by qualified staff.
5. Never hose down or clean the electric motor directly with water or cleaning fluid. If the motor will be used in a washdown environment a washdown designed motor must be used.
6. Never dismantle the pump before the motor has been disconnected from the power supply. Remove the fuses and disconnect the cable from the motor terminal box.
7. Never dismantle the pump until the isolating valves on the suction and discharge side have been closed and the immediate pipe system has been drained. If the pump is used for hot and/or hazardous fluids, special precautions must be taken. In such cases follow the local regulations for personal safety when working with these products.
8. Always ensure that all pipe connections have been fitted and tightened properly before the pump is started. If the pump is used for hot and/or hazardous liquids, take special care: follow the local regulations for personal safety when working with these products.
9. Always wear personal protective equipment according to the requirements established by OSHA, NFPA, NEC (See page 7).
10. Always remove all assembly and auxiliary tools from the pump before starting it up.
11. Make sure product lines and power cables are laid in suitable guides/trays.
12. Always ensure that no debris of any kind is present in the pump.
13. Always ensure that the pump and the motor shafts are properly aligned.
14. Always ensure that the suction and discharge valves isolating the pump are fully open before starting the pump.
15. Never close or obstruct the outlet of the pump as the pressure in the system will increase above the specified maximum pressure of the pump and cause damage to the pump.
16. There are rotating parts in the pump. Never put hands or fingers into a pump while it is in operation.
17. The pump components and piping may contain sharp edges. Handle the rotors carefully because edges may be sharp. Wear gloves while installing and servicing the pump to help avoid injuries from these hazards.
18. Never touch the gear case during operation. The surface temperature may exceed 110°F (43°C). The pump cover and body may be cold or hot depending on the product (CIP at 190°F (88°C) or 300°F (149°C) product, for example).
19. Never touch the motor or motor shroud (if supplied) during operation, as it can become very hot.
20. When moving the pump, use appropriate lifting devices. Attach lifting devices to the eye bolts on the gear case; the gear case has holes for attaching lifting eye bolts. Always use securely fitted lifting straps when lifting with a crane or similar lifting gear.
21. Never drop parts on the floor.
22. Never exceed the maximum temperature or operating pressure specified under “Operating Parameters” on page 12.
23. Guards should be used when applicable. See page 18 and page 125.
24. Make sure to keep the work area clear of machine parts, tools, product lines, foreign materials, and power cables to avoid potential hazards.

Replacement Labels

⚠️WARNING

The following labels are installed on your equipment. If these labels are removed or become unreadable, contact SPX FLOW customer service at 1-800-252-5200 or 262-728-1900, and refer to the part numbers below for replacement labels. See also items 65 and 66 in the parts list section starting on page 66.

Application Instructions

Apply to a clean, dry surface. Remove the backing from the label, place it in proper position, protect it with a cover sheet and burnish it. (A soft rubber roller also may be used to press the label into place.) Apply all labels to be readable from the front of the pump.

**Part no.: 33-63 (040-U2 and smaller pumps)
33-60 (045-U2 and larger pumps)**

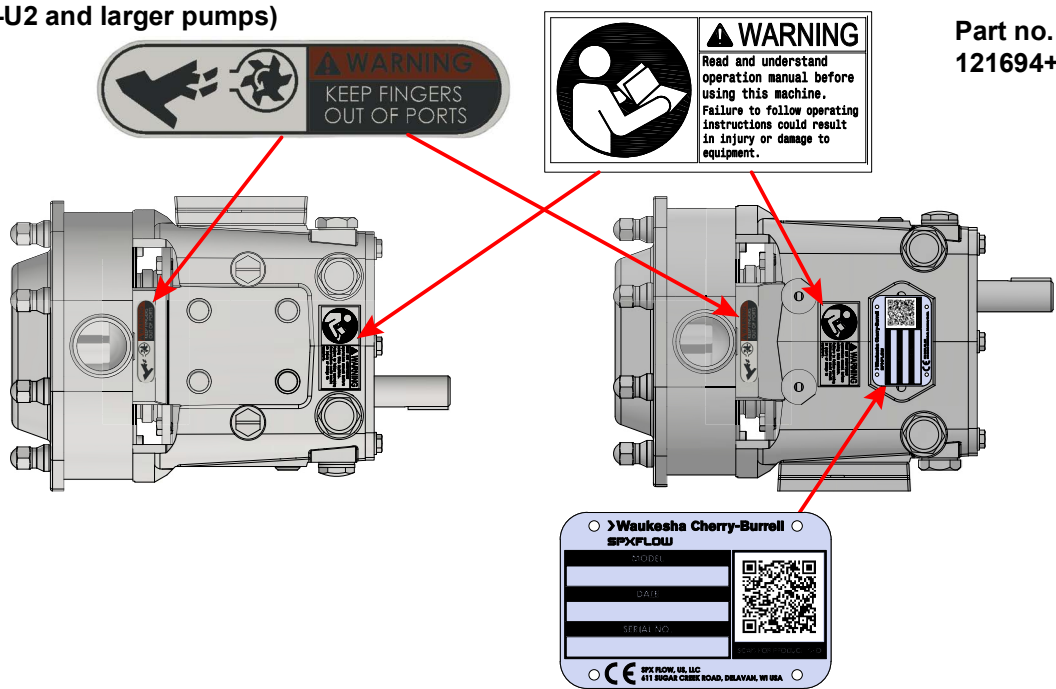

**Part no.:
121694+**

IMPORTANT

1. Pump and Drive are factory aligned.
2. Recheck alignment after installation and before start-up.
3. Recheck alignment periodically, to maximize service life.

PD100-235b 33-95

Part no: 33-95
This label is supplied on base packages, on the side of the gear case.

IMPORTANT

To avoid damage to the shaft seals and/or pump parts:

DO NOT START this pump unless Seal Flush has been installed and is turned ON.

PD100-236a

Part no: 112446+
This label is supplied with pumps with double mechanical seals and single mechanical flush. It is attached to the eye bolt.

Care of Component Materials

NOTE: SPX FLOW recommends the use of an FDA-approved anti-seize compound on all threaded connections.

WARNING

Failure to comply with the Care of Component Materials could lead to bodily injury.

Stainless Steel Corrosion

Corrosion resistance is greatest when a layer of oxide film is formed on the surface of stainless steel. If film is disturbed or destroyed, stainless steel becomes much less resistant to corrosion and may rust, pit or crack.

Corrosion pitting, rusting and stress cracks may occur due to chemical attack. Use only cleaning chemicals specified by a reputable chemical manufacturer for use with 300 series stainless steel. Do not use excessive concentrations, temperatures or exposure times. Avoid contact with highly corrosive acids such as hydrofluoric, hydrochloric or sulfuric. Also avoid prolonged contact with chloride-containing chemicals, especially in presence of acid. If chlorine-based sanitizers are used, such as sodium hypochlorite (bleach), do not exceed concentrations of 150 ppm available chlorine, do not exceed contact time of 20 minutes, and do not exceed temperatures of 104°F (40°C).

Corrosion discoloration, deposits or pitting may occur under product deposits or under gaskets. Keep surfaces clean, including those under gaskets or in grooves or tight corners. Clean immediately after use. Do not allow equipment to set idle, exposed to air with accumulated foreign material on the surface. Corrosion pitting may occur when stray electrical currents come in contact with moist stainless steel. Ensure all electrical devices connected to the equipment are correctly grounded.

Alloy 88

Waukesha Alloy 88 is the standard rotor material for Universal 1, Universal 2, Universal 3, Universal TS, Universal Lobe, Universal 420/520, and 5000 Series Rotary PD pumps. This alloy was developed specifically for corrosion resistance and close operating clearance requirements of high performance rotary positive displacement pumps. Alloy 88 is a nickel based, corrosion-resistant, non-galling or seizing material. The ASTM designation is A494 Grade CY5SnBiM (UNS N26055), and the material is listed in the 3-A Sanitary Standards as acceptable for product contact surfaces.

The corrosion resistance of Alloy 88 is approximately equal to AISI 300 Series Stainless Steel. However, Alloy 88 has limited resistance to certain aggressive chemicals that may be commonly used in contact with AISI 300 Series Stainless Steel.

Do not use Alloy 88 in contact with nitric acid. Nitric acid is commonly used to passivate new installations of stainless steel equipment. Do not allow nitric acid based passivation chemicals to contact Alloy 88 rotors. Remove the rotors during passivation and use a separate pump to circulate the passivation chemicals. Also, if nitric acid-based CIP cleaning chemicals are used, remove the rotors prior to CIP cleaning and clean them separately by hand in a mild detergent. If you have questions regarding other aggressive chemicals, please contact SPX FLOW Application Engineering for assistance.

Elastomer Seal Replacement Following Passivation

Passivation chemicals can damage product contact areas of this equipment. Elastomers (rubber components) are most likely to be affected. Always inspect all elastomer seals after passivation is completed. Replace any seals showing signs of chemical attack. Indications may include swelling, cracks, loss of elasticity or any other noticeable changes when compared with new components.

Introduction

Pump Receiving

⚠ DANGER

The pump contains internal moving parts. DO NOT put hands or fingers into the pump body ports or drive area at any time during operation. To avoid serious injury, DO NOT install, clean, service, or repair the pump unless all power is off and locked out.

All ports are covered at the factory to keep out foreign objects during transit. If covers are missing or damaged, remove the pump cover (if damaged) and thoroughly inspect the fluid head. Be sure that the pumping head is clean and free of foreign material before rotating the shaft.

Each standard Waukesha Cherry-Burrell brand pump is shipped completely assembled and lubricated. Review “Operation” on page 27 before operating the pump.

Intended Use

The Universal 2 Series Rotary Positive Displacement Pump is exclusively intended for pumping liquids, especially in food and beverage installations.

Refrain from using the pump in a manner which exceeds the scope and specifications stated in this manual.

Any use exceeding the margins and specifications set forth is considered to be not intended.

SPX FLOW is not liable for any damage resulting from such activities. The user bears the full risk.

⚠ WARNING

Improper use of the pump leads to:

- damage
- leakage
- destruction
- potential failures in the production process.

Equipment Serial Number

All Waukesha Cherry-Burrell brand pumps are identified by a serial number on the gear case nameplate, which is stamped on the pump body and cover.

⚠ CAUTION

The gear case, body, and cover must be kept together as a unit due to backface, rotor and cover clearances. Failure to do so will damage the pump.

Pump Shaft Location

There are two pump drive shaft locations:

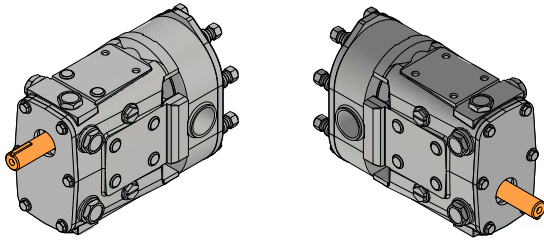

Figure 1 - Upper and Lower Shaft Mount

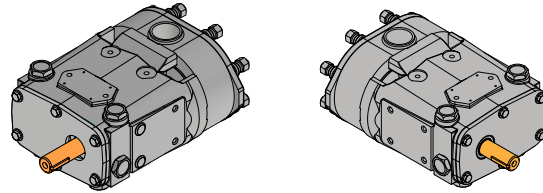

Figure 2 - Sidemount Left Hand and Right Hand
(as viewed from pump cover)

Operating Parameters

U2 Model	Nominal Displacement per revolution	Maximum Nominal Capacity	Inlet/Outlet	Optional Inlet/Outlet	Maximum Product Pressure	Max. RPM
006	.0082 gal (.031 liter)	8 gpm (1.8 m ³ /hr.)	1"	1-1/2"	300 psi (20.7 bar)	1000
015	.0142 gal (.054 liter)	11 gpm (2.5 m ³ /hr.)	1-1/2"	-	250 psi (17.2 bar)	800
018	.029 gal (.110 liter)	20 gpm (4.5 m ³ /hr.)	1-1/2"	2"	200 psi (13.8 bar)	700
030	.060 gal (.227 liter)	36 gpm (8.2 m ³ /hr.)	1-1/2"	2"	250 psi (17.2 bar)	600
040	.076 gal (.288 liter)	46 gpm (10.4 m ³ /hr.)	2"	-	150 psi (10.3 bar)	600
045	.098 gal (.371 liter)	58 gpm (13.2 m ³ /hr.)	2"	-	450 psi (31.0 bar)	600
060	.153 gal (.579 liter)	90 gpm (20.4 m ³ /hr.)	2-1/2"	3"	300 psi (20.7 bar)	600
130	.253 gal (.958 liter)	150 gpm (34.1 m ³ /hr.)	3"	-	200 psi (13.8 bar)	600
180	.380 gal (1.438 liter)	230 gpm (52.2 m ³ /hr.)	3"	-	450 psi (31.0 bar)	600
210, 213	.502 gal (1.900 liter)	300 gpm (68.1 m ³ /hr.)	4"	-	500 psi (34.5bar)	600
220	.521 gal (1.972 liter)	310 gpm (70.4 m ³ /hr.)	4"	-	300 psi (20.7 bar)	600
320, 323	.752 gal (2.847 liter)	450 gpm (102 m ³ /hr.)	6"	-	300 psi (20.7 bar)	600
370	1.099 gal (4.160 liter)	660 gpm (150 m ³ /hr.)	6"	-	200 psi (13.8 bar)	600

U2 Model	Nominal Displacement per revolution	Maximum Nominal Capacity	Inlet W x L Inches	Outlet	Maximum Product Pressure	Max. RPM
014	.0142 gal (.054 liter)	5.68 gpm (1.3 m ³ /hr.)	1.44 x 4.94	1-1/2"	250 psi (17.2 bar)	400
034	.060 gal (.227 liter)	24 gpm (5.5 m ³ /hr.)	1.81 x 6.84	2"	250 psi (17.2 bar)	400
064	.153 gal (.579 liter)	61 gpm (13.9 m ³ /hr.)	2.44 x 9.0	2-1/2"	300 psi (20.7 bar)	400
134	.253 gal (.958 liter)	101 gpm (22.9 m ³ /hr.)	3.19 x 9.38	3"	200 psi (13.8 bar)	400
184	.380 gal (1.438 liter)	152 gpm (34.5 m ³ /hr.)	3.28 x 11.25	3"	450 psi (31.0 bar)	400
214	.502 gal (1.900 liter)	200 gpm (45.4 m ³ /hr.)	3.45 x 12.70	4"	500 psi (34.5bar)	400
224	.521 gal (1.972 liter)	208 gpm (47.2 m ³ /hr.)	4.06 x 11.25	4"	300 psi (20.7 bar)	400
324	.752 gal (2.847 liter)	300 gpm (68.1 m ³ /hr.)	4.25 x 12.70	6"	300 psi (20.7 bar)	400

Other inlet/outlet sizes are available. Contact SPX FLOW Application Engineering.

Pump max temperature is 300°F (149°C).

Operating temperatures depend on the rotor style used. See "Rotor Styles" on page 14 for descriptions.

Rotor Style	For use with liquid temperatures between:*
Standard and Wine Clearance	-40°F (-40°C) to 180°F (82°C)
Front Face Clearance	180°F (82°C) to 200°F (93°C)
316SS Clearance	-40°F (-40°C) to 200°F (93°C)
Hot and Extra Hot Clearance	-40°F (-40°C) to 300°F (149°C)

* Contact SPX FLOW Application Engineering for higher pressures or higher temperature applications.

 DANGER

Operating the pump outside the stated operating parameters may result in severe personal injury or death.

Rotor Styles

"Standard" and "Wine" clearance rotors may be used with liquid temperatures up to 180°F (82°C).

Between 160°-200°F (71°-93°C), consider other application factors such as speed of operation, differential pressure, the lubricating properties of the liquid being pumped, and the product viscosity. If these factors trend toward a difficult application (high speed, high pressure, non-lubricating) then "Front Face" or "Hot" clearance rotors are recommended. Wine clearance rotors (same operating parameters as listed for standard rotors) provide additional clearance between the rotor hub and the cover bore area only. They give extra protection against contact in this area.

"FF" (Front Face) clearance rotors provide additional clearance in the front face area only. They are recommended for use with liquid temperature between 180°F (82°C) to 200°F (93°C). They give better pumping efficiency (less slip) than "Hot" clearance rotors when used with low viscosity liquids. However, do not use "FF" rotors if they will be subjected to temperature shock (extreme, rapid temperature change.)

"Hot" clearance rotors are recommended for use with liquid temperatures between -40°F (-40°C) and 300°F (149°C). They provide additional clearance in the front face area plus rotor to body areas. Because of this additional clearance there is more slip (inefficiency) with low viscosity liquids, which the pump must overcome with higher operating speed (rpm.) VHP (viscous horsepower) is slightly lower when using hot clearance rotors. Hot clearance rotors are also used when the product viscosity is above 200 CPS.

"316SS" clearance rotors are made from 316 stainless steel material (in place of standard non-galling alloy 88) and recommended for use at temperatures up to 200°F (93°C). These rotors provide additional clearance all around (more than Hot clearance alloy 88 rotors) to ensure no running contact between the 316 SS rotors and other 316 SS pump components. Because of this additional clearance, there is more slip (inefficiency) with low viscosity liquids, which the pump must overcome with higher operating speed (rpm). VHP (viscous horsepower) is slightly lower when using "316SS" clearance rotors.

Some models in some series have a "316SS Hot" clearance rotor option for temperatures above 200°F (93°C).

NOTE: Consult SPX FLOW Technical Services for applications near 300°F or above 200°F with 316SS rotors.

"Extra Hot" clearance rotors are recommended for use with products such as chocolate, which tend to "plate out" and build up on rotor surfaces. These rotors require special selection procedures. Contact SPX FLOW Technical Services for assistance.

Single wing rotors are available for certain pump models. They are recommended for applications pumping particulates with minimal damage. These rotors perform the same as standard twin wing rotors. DO NOT USE ABOVE 300 RPM. Single wing rotors are not available for use with RF (rectangular flange) models.

For clearance data, see Table 8, "Rotor Clearances," on page 47.

Certifications

EHEDG

Only pumps containing the elastomers and seals listed on the EHEDG certificate are EHEDG-certified. To maintain compliance, pumps must have process connections that meet EHEDG guidelines and must be mounted in a free-drain position.

Pumps must be connected to process piping using sanitary welds or EHEDG-approved process connections as described in the EHEDG Position Paper, "Easy cleanable Pipe couplings and Process connections" found under "Free Documents" on www.ehedg.org.

To search for EHEDG certificates, go to www.ehedg.org, locate the Testing and Certification" menu heading and select "Certified Equipment." Scroll down to the "Full Text Search" option, type in "SPX FLOW" and select the "Go" button.

3-A

Only designs meeting 3-A Standards are 3-A certified. To maintain compliance, pumps must have process connections that meet 3-A Standards and must be mounted in a free-drain position.

To search for 3-A certificates, go to www.3-a.org/3-A-Symbol/Search-Database-of-Current-Certificates. From here, you can search by Company, Certificate Number, or Standard:

Company: SPX Flow US, LLC
Certificate: 29 (for all SPX FLOW Centrifugal and Rotary Pumps)
Standard: 02-__ for Centrifugal and Positive Rotary Pumps;
63-__ for Sanitary Fittings. ("__" indicates the current revision.)

ATEX

Only pumps that are listed as ATEX on the pump nameplate (see Figure 99 on page 126) are ATEX-certified.

Factory Remanufacturing Program

Waukesha Cherry-Burrell brand Universal 2 pumps are designed so that they may be factory remanufactured twice and backed with a new pump warranty each time.

Factory remanufacturing involves replacement of all shafts, bearings, oil seals, gears, etc. The pump body and cover are re-machined and new oversized rotors are installed. The pumps are stamped R-1 or R-2, after the serial number, designating that they have been reconditioned once or twice.

Contact your SPX FLOW Customer Service Representative at 1-800-252-5200 or 262-728-1900 and furnish the 3 serial numbers (serial tag, pump body, and cover) of any pump being considered for remanufacturing.

Qualification Guidelines for Operating Staff

Definitions

Operator

A person who is capable of handling the installation, interior, operation, warnings, cleaning, repair or transportation of the machine.

Trained person

A person who is instructed in the tasks given and the possible dangerous situation that may occur. The person is also aware of the protection installations and measures.

Skilled worker

A person who based upon his or her background and due to his or her knowledge, is able to perform the tasks, and has an appropriate knowledge of the provisions given.

Table 1: Qualification Guidelines for Operating Staff

Phase of Life	Task Example	Prerequisite for the operating staff	
		Trained person	Skilled worker
Transport	Lift	x	
	Loading	x	
	Unloading	x	
Assembly and Installation/ Commissioning	Assembly/fastening of the machine		x
	Connection to the electric grid		x
	Filling of lubricant to drive motors	x	
Operation	Startup	x	
	Controlling	x	
	Surveillance	x	
	Shutdown	x	
Cleaning, Maintenance	Cleaning	x	
	Refilling of lubricants	x	
	Disconnection from energy supply	x	
	Assembly/Disassembly of parts	x	
Troubleshooting	Disconnection from energy supply	x	
	Troubleshooting	x	
	Assembly/Disassembly of parts	x	
	Repair	x	
Dismounting/Unplugging from plant	Removal of energy supply	x	
	Dismount		x
	Lift		x
	Loading		x
	Unloading		x

Installation

Important Safety Information

⚠ DANGER

The pump contains internal moving parts. DO NOT put hands or fingers into the pump body ports or drive area at any time during operation. To avoid serious injury, DO NOT install, clean, service, or repair the pump unless all power is off and locked out and the pump is de-pressurized.

⚠ WARNING

The pump components and piping may contain sharp edges. Handle the rotors carefully because edges may be sharp. Wear gloves while installing and servicing the pump to help avoid injuries from these hazards.

⚠ CAUTION

Maintenance should be performed only by trained personnel. See “Qualification Guidelines for Operating Staff” on page 16.

Lifting

Table 2: Pump Weights (less motor or base)	
U2 Model	Weight lb (kg)
006, 015	56 (25.4)
014	47 (21)
018	65 (29.5)
030	130 (59)
034	100 (45)
040	140 (64)
045	295 (134)
060	285 (129.3)
064	255 (116)
130	305 (138.3)
134	280 (127)
180, 184	520 (236)
220	590 (268)
224	505 (229)
210, 213, 214	915 (415)
320, 323, 324	895 (406)
370	945 (428.6)

Attach lifting straps/chains to the two eye bolts on the top of the gear case.

⚠ CAUTION

When moving the pump, use appropriate lifting devices. Always use securely fitted lifting straps/chains when lifting with a crane or similar lifting gear.

⚠ WARNING

Do not stand underneath the pump while it is being lifted.

⚠ CAUTION

To lift the cover on a 210 or larger U2, attach an eye bolt to the threaded hole in the cover and attach lifting straps or chains to the eye bolt.

To lift the jacketed cover on an 045 or larger U2, attach an eye bolt to the threaded hole on the jacket and attached lifting straps or chains to the eye bolt.

To lift the body of a 130 or larger U2, use a lifting strap threaded through the ports on either side of the body. To lift the gear case assembly on pumps larger than 015-U2, attach lifting straps/chains to the two eye bolts on the top of the gear case.

⚠ CAUTION

For Unit orders (a pump and motor mounted on a common baseplate (not pictured)), use straps to lift the unit by the baseframe at either end. Do not lift by the eye bolts on the pump or motor. Due to the wide range of pump sizes and motors, SPX FLOW cannot give lifting instructions here for all configurations. Contact SPX FLOW or an authorized lifting expert if questions arise.

Install Pump and Drive Unit

⚠ CAUTION

The motor must be installed by qualified personnel, e.g., a licensed electrician.

All system equipment, such as motors, sheaves, drive couplings, speed reducers, etc., must be properly sized to ensure satisfactory operation of your Waukesha Cherry-Burrell brand pump within its limits. Customer-supplied motors should have a basic level of safety to prevent electrical hazards, and should be dealt with in accordance with the manufacturer's instructions.

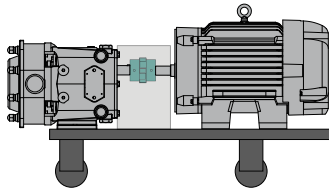

Figure 3 - Portable Base

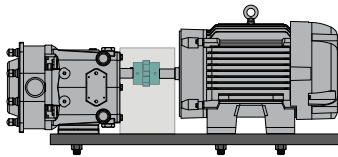

Figure 4 - Adjustable Leg Base

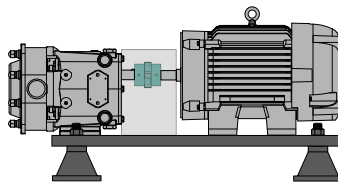

Figure 5 - Leveling and/or Vibration Isolation Pads

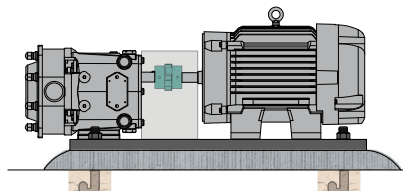

Figure 6 - Permanent Installation on Foundation

In a typical installation configuration, the pump and drive unit are mounted on a common base plate. The unit can be installed in any of the arrangements shown in Figure 3 through Figure 6.

NOTE: The gap between the pump body and gear case is required for 3-A sanitary standards.

NOTE: When installing a unit as shown in Figure 6, level the unit before installing the bolts.

The shaded area in Figure 3 through Figure 6 indicates the guard location.

See "Pump Shaft Guards" on page 125.

⚠ WARNING

Full guards must be installed to isolate operators and maintenance personnel from rotating components.

Guards are provided as part of a complete pump and drive package and are selected by SPX FLOW Engineering for the pump, base, and motor ordered. Do not modify the guard provided by SPX FLOW. If the guard provided by SPX FLOW is lost, contact SPX FLOW Customer Service and provide your order number or PO number of the pump to order a correctly-sized replacement guard.

If the pump was not purchased as a unit, it is the responsibility of the customer to ensure proper guarding. Refer to your local regulations for guidance.

Install Connections and Piping

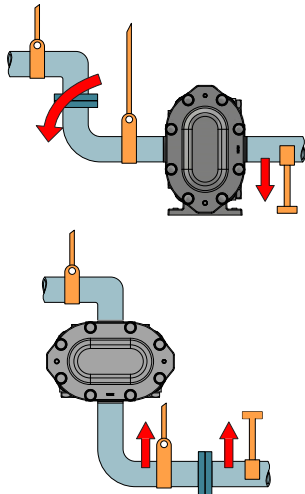

Figure 7 - Piping Support

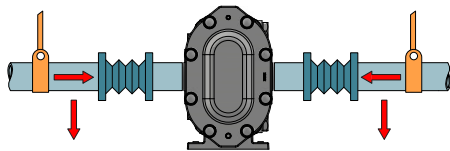

Figure 8 - Flexible Connections and Supports

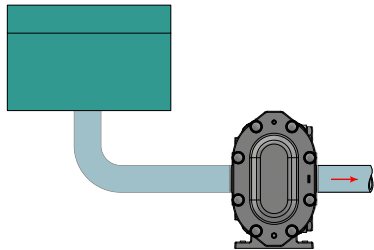

Figure 9 - Pump Below Supply (recommended)

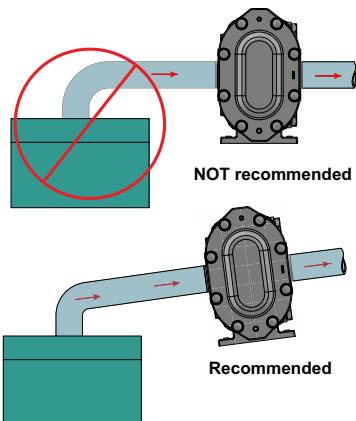

Figure 10 - Piping Slope

Piping Support

To minimize forces exerted on the pump, support all piping to the pump independently with hangers or pedestals. Such forces can cause misalignment of the pump parts and lead to excessive wear of rotors, bearings, and shafts.

Figure 7 shows typical supporting methods used to independently support each pipe, reducing the weight effect of piping and fluid on the pump.

⚠ WARNING

Do not exceed 50 lb (22.7 kg) load on pump inlet or discharge ports. Exceeding this limit may cause damage to the pump.

Expansion Joints

Thermal expansion of piping can cause tremendous forces. Use thermal expansion joints to minimize these forces on the pump.

Flexible joints can be used to limit transmission of mechanical vibration. Ensure that the free ends of any flexible connections in the system are anchored.

Inlet Piping

Install the pump below the supply liquid level to reduce the air in the system by flooded suction, to prevent the pump from becoming air-bound (Figure 9).

If the pump is installed above the supply liquid level, the piping on the inlet side must slope up toward the pump, preventing air pockets in the pipes (Figure 10).

Install Check Valves

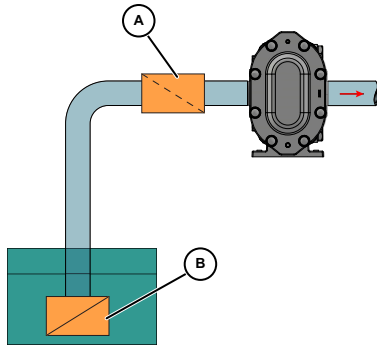

- A. Inlet Check Valve
- B. Foot Check Valve

Figure 11 - Inlet Check Valve

Inlet Side on Lift Applications

Use check valves to keep the inlet line full, particularly with low-viscosity fluids (Figure 11).

Discharge Side

For systems with liquid under a vacuum, install a check valve on the discharge side of the pump. The check valve prevents back-flow (air or fluid) to aid in the initial start-up by minimizing the required differential pressure supplied by the pump to start the flow (Figure 12).

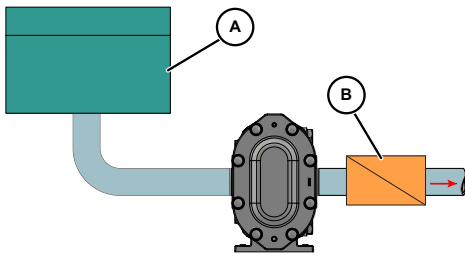

- A. Closed Tank - produces vacuum on liquid (Low Absolute Pressure)
- B. Check Valve (outlet)

Figure 12 - Discharge Check Valve

Install Isolation Valves

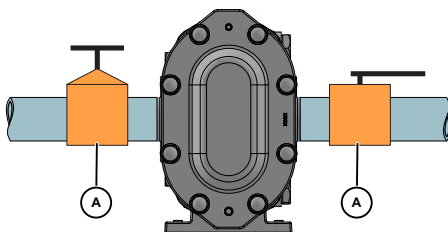

Figure 13 - Isolation Valves

Isolation valves permit pump maintenance and safe pump removal without draining the system (Figure 13, item A).

NOTE: Make sure the inlet flow is not restricted. Don't start the pump deadheaded, e.g., operated with no flow through it.

Install Relief Valves

Install relief valves to protect the pump and piping system against excessive pressure. We recommend installing an external relief valve designed to bypass fluid from the pump outlet to the inlet side of the system (See Figure 14, Figure 15, and Figure 16).

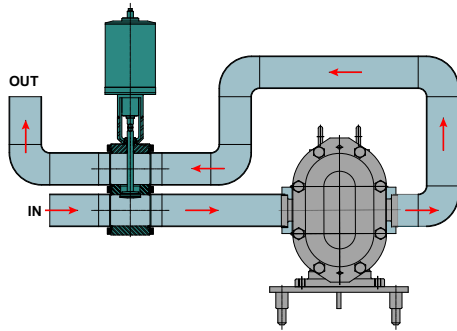

Figure 14 - WR63 Reverse-Acting Over-Pressure Relief Valve

NOTE: Integral relief valves built into the pump covers, also known as “vented covers” (not shown), are available. These covers are not “CIP-able” and must be disassembled for cleaning. They are not recommended on applications with viscosities over 5000 cP or where the discharge must be closed for more than a few minutes.

⚠ CAUTION

Prolonged operation of the pump with closed discharge will cause heating of the fluid circulating through the relief valve. If this is the case, install an external relief valve to discharge externally through the piping connected to the fluid source, or into inlet piping near the source. Contact SPX FLOW Application Engineering for sizing an external relief valve.

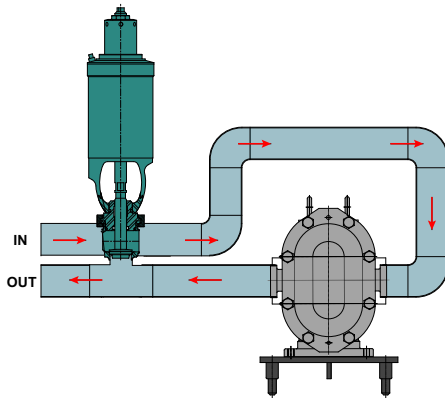

Figure 15 - WR61C Air-to-Raise Valve with Adjustable-Spring Actuator

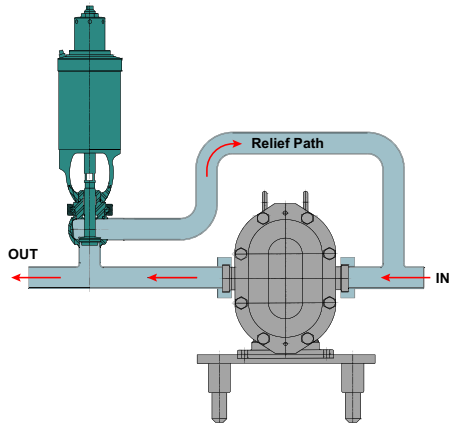
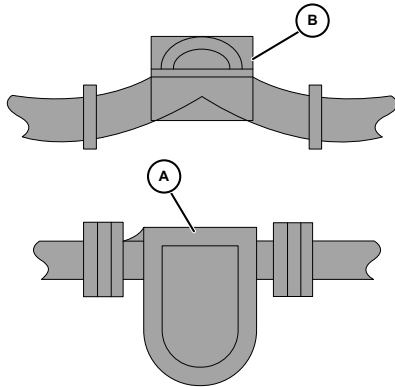

Figure 16 - WR61T 4RHAR Valve

Inlet Side Strainers and Traps



A. Strainer B. Magnetic Trap

Figure 17 - Inline Strainers and Traps

Inlet side strainers and traps (Figure 17, items A and B, respectively) can be used to prevent foreign matter from damaging the pump. Select carefully to prevent cavitation caused by restricting the inlet. If inlet strainers are used, service them regularly to prevent clogging and flow stoppage.

Install Pressure Gauges

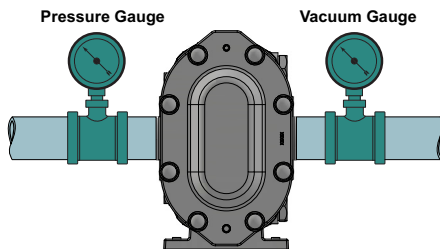
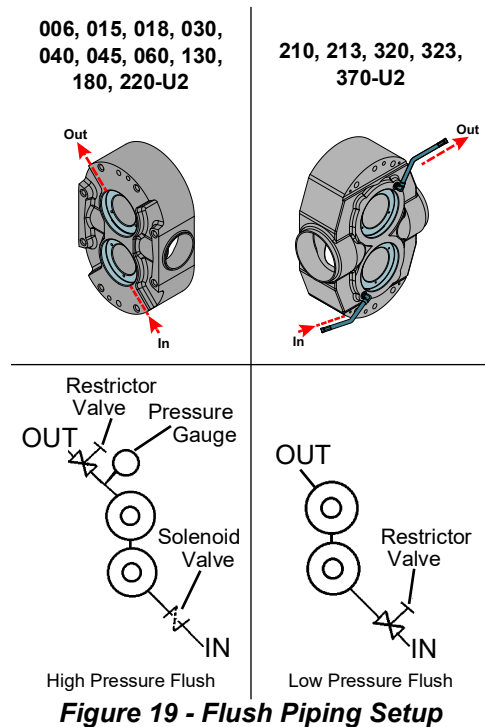

Figure 18 - Pressure and Vacuum Gauges

Pressure and vacuum gauges provide valuable information about pump operation (Figure 18). Wherever possible, install the gauges to help provide information on the following:

- Normal or abnormal pressures
- Indication of flow
- Changes in pump condition
- Changes in system conditions
- Changes in fluid viscosity

Seal Flush Connections



NOTE: If the pumped product contains abrasive solids or hardens on the seal faces, an alternate high pressure barrier flush arrangement may be used. A very small amount of flush liquid enters the pumped liquid, therefore the flush media must be compatible with the product.

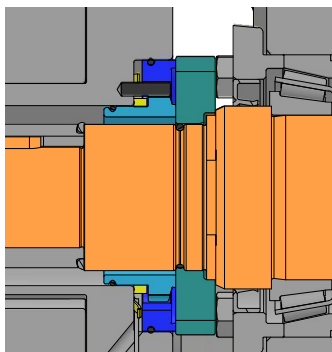

Figure 20 - HPB Seal

⚠ WARNING

Operating the pump without flush will damage the seal and pump parts due to excess heat from dry running.

Pumps with double seals require flushing. The flush media (water or lubricating fluid compatible with the product) must be connected and flowing whenever the pump is operated.

Pump bodies have two 1/8-inch female pipe thread (NPT) flush connections located near the bottom and top of the body.

1. Connect the flush inlet to the lower connection, and outlet to upper connection to flood the flush area completely.
2. Connect the flush outlet for unrestricted flow to the drain.
 - If steam is used as a flush media, connect the inlet at the upper connection, and the outlet at the lower connection to ensure condensation removal.
 - If steam condensate is used as a flush media, connect the inlet at the lower connection, and the outlet at the upper connection.
3. Use cool, filtered flush media to obtain maximum service life of the seal components. If the pumped product is sticky or solidifies at room temperature, use warm or hot flush media.
4. Install a pressure reducing valve and flow control valve (needle valve) on the flush supply line. Set the supply pressure at a maximum of 30 psi (2 bar) and adjust the flow rate to approximately 1/4 gpm (more for high temperature applications).
5. Install a solenoid valve in the flush supply and wire it in series with the motor starter to provide an automatic start/stop of the flush media flow before the motor turns on and after the motor turns off.

Universal 2 High-Pressure Barrier (HPB) Seals

The Universal 2 High Pressure Barrier (HPB) Seal is available in the Double Mechanical Seal Design only.

The maximum barrier pressure is 100 psi.

Recommended seal flush flow is 1/8 gpm.

To calculate the barrier pressure to ensure that the barrier fluid is on the seal instead of the product:

$$((D_p - S_p) \times 30\%) + S_p + 30 \text{ psi} = B_p$$

D_p = pump discharge pressure

S_p = pump suction pressure

B_p = flush water pressure

Contact SPX FLOW Application Engineering for assistance.

CIP (Clean-In-Place) Features

Universal 2 pumps with optional CIP features are designed to provide complete access of the CIP solutions to all product contact surfaces.

Standard CIP features

- Flat body profile (minimum requirement for standard CIP installations) allows complete draining of the side-mounted pump, and provides the CIP solution access to the entire cover O-ring groove.

Particulate CIP features

NOTE: *Particulate CIP is also known as "Full" CIP. This option decreases the pump efficiency.*

- Flat body profile (minimum requirement for standard CIP installations) allows complete draining of the side-mounted pump, and provides the CIP solution access to the entire cover O-ring groove.
- Holes in the rotor hubs and body hubs provide additional "Full CIP" solution access to the cover hub/shaft seal areas for difficult cleaning applications.

Guidelines

Use the following guidelines when designing and installing the CIP system to ensure successful cleaning:

- Ensure that the velocity rate of CIP solutions is adequate to clean the entire circuit. For most applications, a velocity of 5 ft/sec is sufficient. For the CIP solution to achieve the proper velocity, the pump drive must have enough speed range and horsepower. The required inlet pressure also must be satisfied. If the pump does not supply enough CIP solution velocity, a separate CIP supply pump with an installed bypass may be used. To determine the appropriate bypass arrangement, contact SPX FLOW Application Engineering.
- Ensure that a differential pressure is created across the pump. Differential pressure will push CIP solutions through close-clearance areas of the pump, resulting in better cleaning action. The high pressure side may be either the inlet or outlet side. 30 psi (2 bar) differential pressure is adequate for most applications. For difficult cleaning applications, higher pressure or longer cleaning cycles may be required.
- The pump must be operated during CIP to increase turbulence and cleaning action within the pump.
- If complete draining is required, the pump must be in the side mount position.

CAUTION

In order to avoid temperature shock after the introduction of hot CIP fluid, stop the pump after filling the pumphead with hot CIP fluid. Once the hot CIP fluid has filled the pumphead, allow up to 15 minutes for the pump fluid components to thermally expand, then re-start the pump.

Check Coupling Alignment



Figure 21 - Lovejoy Coupling



Figure 22 - T.B. Woods® Coupling

Pumps and drives ordered from the factory and mounted on a common base plate are aligned before shipment. Alignment **must** be re-checked after the complete unit has been installed and piping completed. Periodic re-checking is advisable during the pump service life.

- SPX FLOW recommends using a flexible coupling to connect the drive to the pump. Several different types are available, including couplings with slip or overload provisions. SPX FLOW provides Lovejoy (Figure 21) or T.B. Woods® (Figure 22) couplings unless otherwise specified when ordering. Flexible couplings can be used to compensate for end play and small differences in alignment.
- Align the pump and drive shaft as closely as possible. Pump and drive are factory-aligned.
 - Re-check alignment after installation and before start-up.
 - Re-check alignment periodically, to maximize service life.

Check Angular Alignment

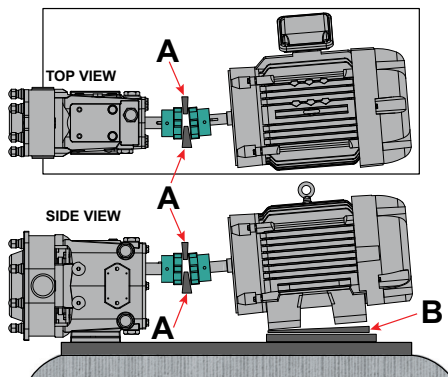

Figure 23 - Check Angular Alignment

1. Using feeler gauges or taper gauges (Figure 23, items A and B), check the alignment at four points every 90 degrees around the coupling; **adjust to equal dimension at all points.**
2. Set the space between the coupling halves to the manufacturer's recommended distance.
3. Install shims to bring the system into alignment.

Check Parallel Alignment

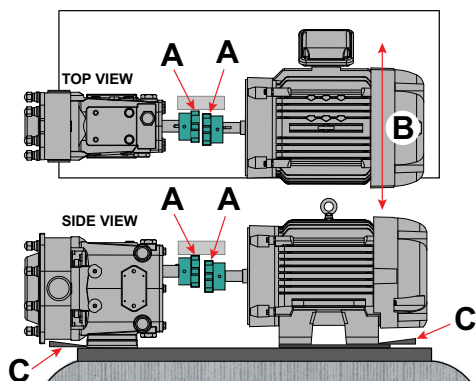

Figure 24 - Check Parallel Alignment

1. Check both the horizontal and vertical alignment of the pump and drive using a straight edge.
2. Using a feeler gauge at location "A" in Figure 24, determine the direction and amount of movement needed (Figure 24, item B).
3. If necessary, shim at location "C" and/or move drive as needed.

Check Belt and Chain Drive Alignment

Use a straight edge to visually check the belt or chain alignment. Keep the shaft distance to a minimum (Figure 25, item A).

After the piping is complete and before the belts are installed, manually turn the pump shaft to ensure it turns freely.

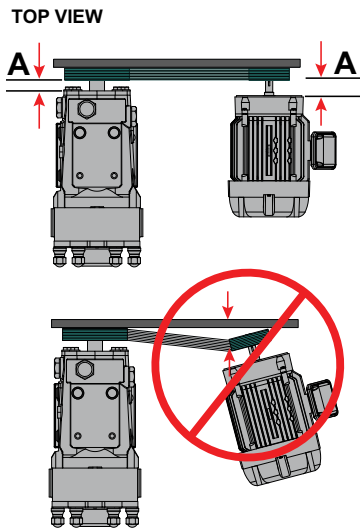

Figure 25 - Belt and Chain Drive

Check Pump Rotation

After the correct drive rotation is verified, connect the coupling and assemble the pump and coupling guards.

NOTE: The pump is bidirectional unless it is supplied with optional suction vents.

CAUTION

The pump covers in the following figures have been removed to view the rotor rotation. Never operate the pump with the covers removed.

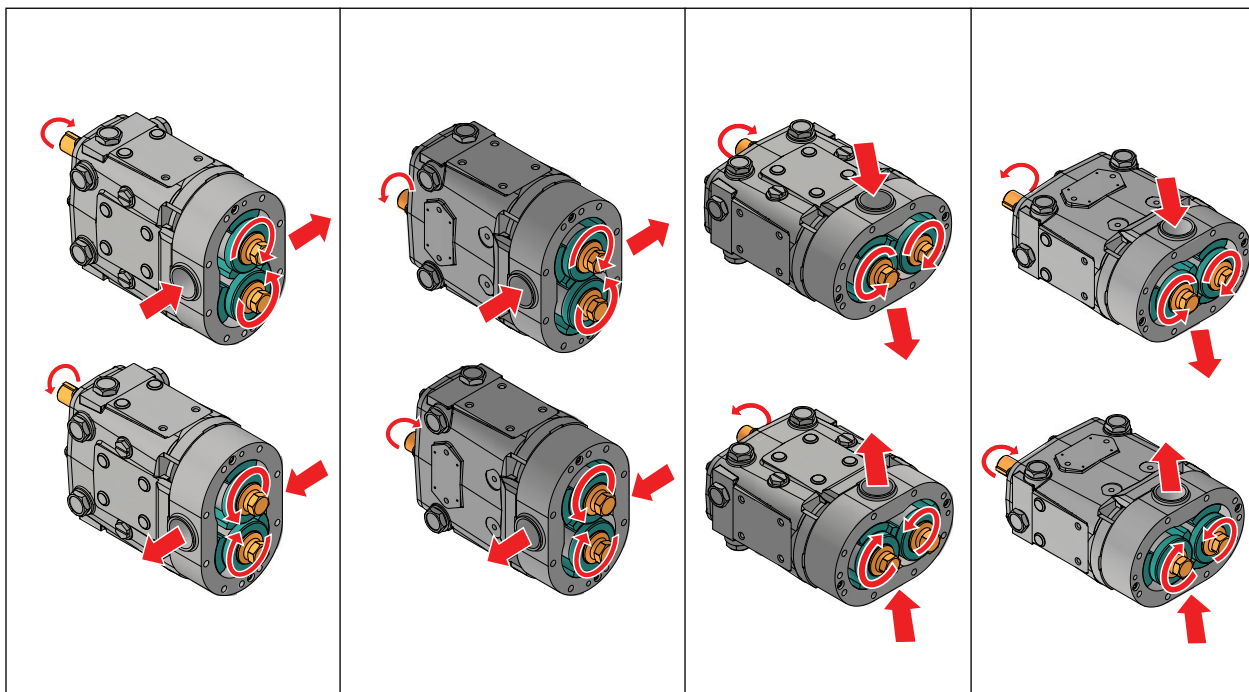

Figure 26 - Upper Shaft Drive Flow, Lower Shaft Drive Flow and Vertical Porting Flow and Pump Rotation (Liquid End Shown)

Operation

⚠ DANGER

The pump contains internal moving parts. **DO NOT** put hands or fingers into the pump body ports or drive area at any time during operation. To avoid serious injury, **DO NOT** install, clean, service, or repair the pump unless all power is off and locked out.

⚠ CAUTION

These pumps are positive displacement, low slip design and will be severely damaged if operated with closed valves in the discharge or inlet lines. The pump warranty is not valid for damages caused by a hydraulic overload from operation or start-up with a closed valve in the system.

Pre-Startup Checklist

⚠ CAUTION

Do not use this pump to flush a newly-installed system. Severe damage may occur to the pump and system if the pump is used to flush the system.

Remove the rotors during system flushing, to prevent debris from being trapped between the rotors and the pump body. This debris may damage the pump upon startup.

⚠ WARNING

Full guards must be installed to isolate the operators and maintenance personnel from the rotating components.

Guards are provided as part of a complete pump and drive package. The gap between the pump body and gear case is required for 3-A sanitary standards.

⚠ WARNING

Do not start a pump with seal flush unless the seal flush is installed and turned on.

1. Ensure that the pump is correctly installed as described in "Installation" on page 17. Review "Install Relief Valves" on page 21 and install relief valves as needed.
2. Check the coupling alignment. See "Check Coupling Alignment" on page 25.
3. Ensure that the pump and piping are clean and free of foreign material such as welding slag, gaskets, etc.
4. Ensure that all piping connections are tight and leak-free. Where possible, check the system with non-hazardous fluid.
5. Ensure that the pump and drive are lubricated. See "Lubrication" on page 29.
6. Ensure that all guards are in place and secure.
7. Double mechanical seals require adequate supply and flow of clean flushing fluids.
8. Ensure that all valves are open on the discharge side and a free flow path is open to the destination.
9. Ensure that all valves are open on the inlet side and fluid can fill the pump. A flooded suction installation is recommended.
10. Check the direction of pump and drive rotation to ensure that the pump will rotate in the proper direction. See "Check Pump Rotation" on page 26.

Startup Procedure

⚠ CAUTION

In order to avoid temperature shock after the introduction of hot or cold product, stop the pump after filling the pumphead with product. Once the product has filled the pumphead, allow up to 15 minutes for the pump's fluid components to thermally adjust, then re-start the pump

1. Start the pump drive. Where possible, start at a slow speed or jog.
2. For sanitary applications, sanitize the pump per customer requirements before putting the pump into service.
3. Check to make sure that the liquid is reaching the pump. If pumping does not begin and stabilize, check "Troubleshooting" on page 62.

Shutdown Procedure

1. Shut off the power to the pump drive.
2. Shut off the supply and discharge lines.

Emergency Shutdown Procedure

Emergency Shutdown Procedures should be documented by plant personnel after assessing system-wide requirements.

Maintenance

Important Safety Information

⚠ DANGER

The pump contains internal moving parts. **DO NOT** put hands or fingers into the pump body ports or drive area at any time during operation. To avoid serious injury, **DO NOT** install, clean, service, or repair the pump unless all power is off and locked out and the pump is de-pressurized.

⚠ WARNING

The pump components and piping may contain sharp edges. Handle the rotors carefully because edges may be sharp. Wear gloves while installing and servicing the pump to help avoid injuries from these hazards.

⚠ WARNING

Never touch the gear case during operation. The surface temperature may exceed 110°F (43°C). The pump cover and body may be cold or hot depending on the product (CIP at 190°F (88°C) or 300°F (149°C) product, for example).

⚠ CAUTION

Maintenance should be performed only by trained personnel. See “Qualification Guidelines for Operating Staff” on page 16.

⚠ CAUTION

Make sure the pump is securely bolted or clamped down prior to performing any maintenance work. The pump center of gravity changes as parts are added or removed, and could result in tipping of an unsecured pump.

⚠ CAUTION

Make sure to keep the work area clear of machine parts, tools, product lines, foreign materials, and power cables to avoid potential hazards.

⚠ CAUTION

Make sure appropriate lighting is available: at least 1000 lux, independent of daylight and weather conditions.

⚠ CAUTION

Before carrying out any maintenance and repair work on cold components, ensure that the machine parts in question are sufficiently heated. The contact temperature of accessible machine parts must not be lower than those in the EN ISO 13732-1.

⚠ CAUTION

To lift the cover on a 210 or larger U2, attach an eye bolt to the threaded hole in the cover and attach lifting straps or chains to the eye bolt.

To lift the jacketed cover on an 045 or larger U2, attach an eye bolt to the threaded hole on the jacket and attached lifting straps or chains to the eye bolt.

To lift the body of a 130 or larger U2, use a lifting strap threaded through the ports on either side of the body. To lift the gear case assembly on pumps larger than 015-U2, attach lifting straps/chains to the two eye bolts on the top of the gear case.

Before detaching port connections to the pump:

- Close the suction and discharge valves.
- Drain the pump and clean or rinse, if necessary.
- Disconnect or shut off the electrical supply and lock out all power.

Lubrication

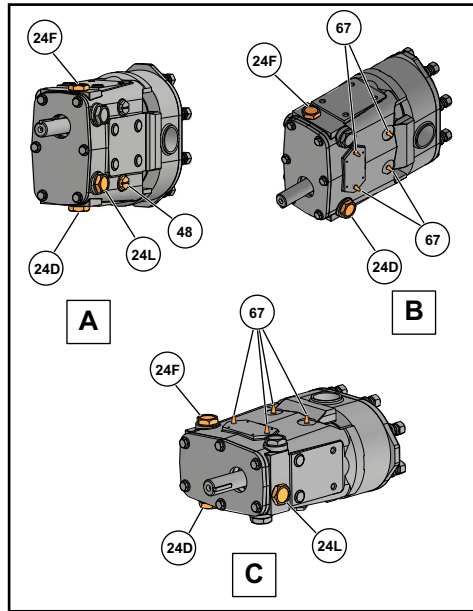

Figure 27 - Lubrication Points

- A. Upper Shaft Drive Pump (Standard)
- B. Lower Shaft Drive Pump (Optional)
- C. Side-Mount Pump (Optional)
- 24D. Oil Drain Plug
- 24F. Oil Fill Plug
- 24L. Oil Level Check Plug, Sight Glass
- 48. Grease Clean-out Plug
- 67. Grease Fittings

Gear Oil Specification

ISO Grade 320, SAE 140 or AGMA Number 6EP, part number 118402+. If food-grade oil is required, use part number 000140003+.

Bearing Lubricant Grease

NLGI Grade No. 2, EP, Lithium-based lubricant is standard, part number 118401+. If food-grade grease is required, use part number 000140002+.

Drive Lubrication

Refer to the manufacturer's manual shipped with the drive for proper drive lubrication and frequency.

Gears

Gears are factory-lubricated with gear oil at the quantity shown in Table 3. **Change the oil every 750 hours.**

NOTE: Aggressive washdown or extreme running conditions may require more frequent lubrication intervals.

When the pump is not running, the gear oil level is correct when the oil level is visible in the sight glass.

When the pump is running, the oil level may be difficult to see and may appear cloudy.

Universal pumps are shipped with the oil level at or slightly above the sight glass.

Bearings

Bearings are factory-lubricated with grease. Re-lubricate them at the quantity shown in Table 3 on page 29. **Grease the bearings every 750 hours.**

NOTE: Aggressive washdown or extreme running conditions may require more frequent lubrication intervals.

Excess grease will accumulate in the gear case and must be removed through the cleanout hole covered with a plastic plug (Figure 27, item 48).

Best practice is to clean out this area every time you grease the pump. Water can accumulate in the gear case from condensation or from aggressive washdown. If water is found in the gear case, clean out this area more frequently.

Table 3: Lubrication Quantities

Universal 2 Model	Oil Capacity (Gears)		Grease Quantity (per Bearing)	
	Top or Bottom	Side Mount	Front	Rear
006, 014, 015, 018	1.3 oz (40 ml)	3.3 oz (100 ml)	.37 oz (11 cc)	.13 oz (4 cc)
030, 034, 040	2.0 oz (60 ml)	4 oz (120 ml)	.60 oz (18 cc)	.21 oz (6 cc)
045, 060, 064, 130, 134	6.0 oz (170 ml)	9.5 oz (280 ml)	.84 oz (25 cc)	.76 oz (22 cc)
180, 184, 220, 224	11 oz (320 ml)	20 oz (600 ml)	1.33 oz (39 cc)	1.03 oz (30 cc)
210, 213, 214, 320, 323, 324, 370	17 oz (500 ml)	44 oz (1300 ml)	1.96 oz (58 cc)	1.16 oz (34 cc)

Maintenance Inspections

⚠ DANGER

The pump contains internal moving parts. DO NOT put hands or fingers into the pump body ports or drive area at any time during operation. To avoid serious injury, DO NOT install, clean, service, or repair the pump unless all power is off and locked out.

Detecting wear in the early stages can reduce repair costs and downtime. A simple “look-feel” inspection of the pump during breakdown cleaning is recommended to detect signs of trouble at an early stage.

A detailed maintenance inspection should be scheduled annually. See “Annual Maintenance” on page 31.

Refer to the “Maintenance Inspection Chart” on page 32 for possible causes and solutions to common issues discovered during inspection.

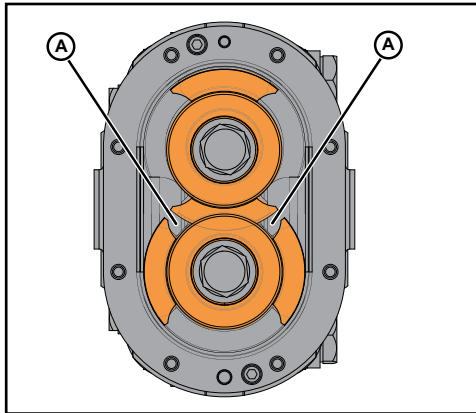

Figure 28 - Rotor to Rotor Tip Clearance

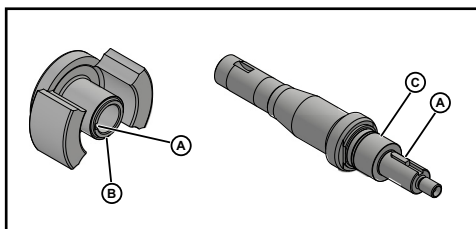

Figure 29 - Rotor and Shaft Inspection

Inspection of Rotor Tips

Remove the cover (see “Remove Cover” on page 34) and check for metal-to-metal contact between the rotor wings. When contact is detected, repair or replace the pump.

Visually inspect the rotors for rotor tip to rotor tip contact and rotor tip to rotor hub contact. Manually rotate the pump drive shaft and ensure that the rotor tip clearance is equal on both sides as indicated in Figure 28.

Inspection of Rotor, Shaft Key, and Keyway

Visually inspect the rotor, shaft key, and rotor keyway (Figure 29, item A) for excessive wear; replace them as necessary.

NOTE: The shaft key or keyway should not show signs of wear. The key is not a load-carrying device and is used for proper alignment only. If wear is observed on or near the keyway, this indicates that the rotor nuts may be torqued incorrectly. Torque the rotor nuts to the specifications in Table 4.

Table 4: Rotor Nut Torque

U2 Model	Rotor Nut Torque
006,014 015, 018	50 ft-lb (68 N·m)
030, 034, 040	120 ft-lb (163 N·m)
045, 060, 064, 130, 134	250 ft-lb (339 N·m)
180,184, 220, 224	325 ft-lb (441 N·m)
210, 213, 214, 320, 323, 324, 370	375 ft-lb (508 N·m)

Inspection of Shaft

Visually inspect the shaft for twists or bends; replace it as necessary.

Inspection of Rotor Hub End

Visually inspect the rotor hub end (Figure 29, item B) for excessive wear; replace it as necessary. Each time the rotors are removed, replace the O-rings on the hub.

Inspection of Shaft Shoulder

Visually inspect the shaft shoulder (Figure 29, item C) for excessive wear; replace it as necessary. If the shaft shoulder has a sharp edge, remove the edge with a file to prevent cutting the shaft O-ring on installation

NOTE: Rotor hub and shaft shoulder wear are caused by operating with a loose rotor nut(s) for extended periods.

Inspection of Gears and Bearings

Gear backlash

With the fluid head and seals removed, feel for gear backlash by rotating either shaft by hand. The other shaft must engage immediately. Perform this check three times at 60-degree intervals. If play (backlash) is evident, remove the gear case cover, check the gear teeth for wear, and ensure that the gear is not loose on the shaft. If the gear teeth are worn, replace the gears. If the gear is loose on the shaft, inspect the shaft key and keyway; replace as necessary.

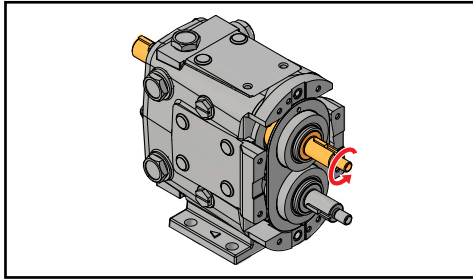

Figure 30 - Backlash Check

Check bearing condition

With the fluid head and seals removed, check the bearing condition by applying (by hand) an up or down force of approximately 30 lbs (14 kg). If movement is detected, the bearing may be failing. Also check the shaft movement forward or backward. If the bearing is failing, replace the bearing and review the lubrication section starting on page 29.

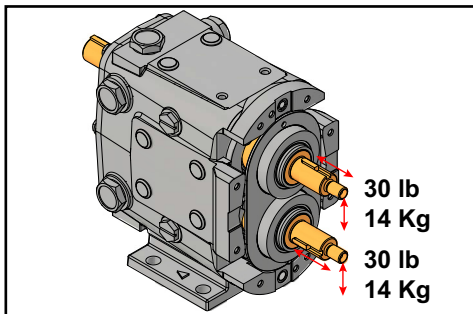

Figure 31 - Bearing Deflection Check

Annual Maintenance

⚠ DANGER

The pump contains internal moving parts. DO NOT put hands or fingers into the pump body ports or drive area at any time during operation. To avoid serious injury, DO NOT install, clean, service, or repair the pump unless all power is off and locked out.

At least annually, perform the procedures and corrective measures outlined in “Maintenance Inspections” on page 30, in addition to the following preventive maintenance:

- Check the bearings with a dial indicator for shaft radial play. If the deflection is equal to or greater than the rotor-to-body diametrical clearance (“Checking for Proper Clearance” on page 46), replace the bearings.
- Remove the gear cover and inspect the gears for wear, backlash and looseness. Loosen and torque the gear locknuts to the proper torque.
- Thoroughly inspect the rotors for worn keyways, hub wear and stress cracks. Use the dye check method to detect any fatigue-type cracks at rotor stress points (Figure 32, item A).
- Review the performance record on the pump, and check the radial and backface clearances to determine wear and effect on performance. Adjustment to the operating speed can compensate for wear in some applications.

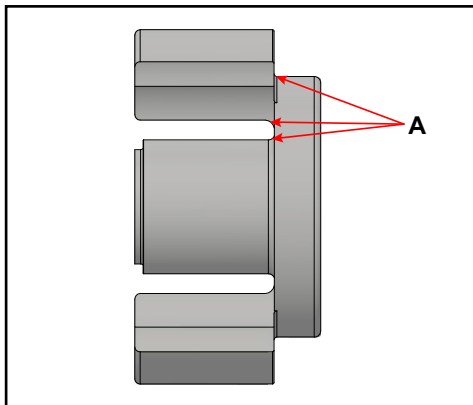

Figure 32 - Rotor Stress Points

⚠ CAUTION

When bearings or shafts are replaced in the field, take care to correctly position the shaft by shimming it to maintain sufficient running clearances between the rotor wing faces and the pump body faces (backface and cover face). It is important to hold the same backface dimension for both rotors to avoid crossover interference.

Maintenance Inspection Chart

Frequency	Check for	Possible Causes	Possible Solutions
At least weekly	Low oil level, oil contamination, oil leaks	Oil leak from gear case cover oil seal or gear case rear oil seal Loose back cover Oil plug damaged	Replace oil seals (items 12 & 13 in the parts lists starting on page 67) Check or replace oil plug. See "Lubrication" on page 29.
Weekly	Leaks - Product	Damaged seals Damaged elastomers	Replace seals Replace elastomers
Weekly	Leaks - Flush fluid	Damaged seal, fitting, or flush tube Damaged flush-side seal components Damaged elastomers.	Replace seal, fitting, or flush tube Replace flush-side seal components Replace elastomers
Monthly	Excess grease in cleanout plugs	Excess grease accumulates as part of normal operation	Remove excess gear oil from cleanout plugs (Figure 27, item 48 on page 29).
Every 3 months	Damaged front grease seals.	Seal may be old and worn. No grease on lips to lubricate. Shaft worn under seals.	Replace seals. Properly lubricate with grease when installing. Inspect shaft surface under seals.
Every 3 months	Damaged rear oil seals.	Seal may be old and worn. No grease on lips to lubricate. Shaft worn under seals. Not centered on shaft when installed.	Replace seals. Properly lubricate with grease when installing. Inspect shaft surface under seals.
Every 3 months	Rotor tip to rotor tip contact or uneven rotor tip to rotor tip clearance.	Hard object jammed into rotors and twisted shafts.	Replace shafts. Install strainers if necessary. Check and replace gears if necessary.
Every 3 months	Rotor tip to rotor hub contact.	Loose rotor nut(s). Belleville-style washer(s) on backwards. Backface clearances not even. Bearings need replacing.	Torque rotor nut(s) properly. Install belleville-style washers correctly. Verify backface clearances are even. Check and replace bearings.
Every 3 months	Worn rotor or shaft keyway(s). Worn or damaged rotor key(s).	Loose rotor nut(s). Belleville-style washer(s) on backwards.	Replace rotors, shafts and keys. Torque rotor nut(s). See Table 15 on page 60. Install belleville-style washer(s) correctly.
Every 3 months	Worn rotor hub end or shaft shoulder.	Loose rotor nut(s). Belleville-style washer(s) on backwards. Rotors slammed against shoulder when installed.	Torque rotor nut(s). See Table 15 on page 60. Install belleville-style washer(s) correctly. Replace rotors and shafts or shim front bearing(s) to maintain proper backface clearances.
Every 3 months	Sharp edged shaft shoulder.	Loose rotor nut(s). Belleville-style washer(s) on backwards. Rotors slammed against shoulder when installed. Backface clearances not even.	Torque rotor nut(s). See Table 15 on page 60. Install belleville-style washer(s) correctly. Remove sharp edge with file to prevent cutting shaft O-ring. Verify backface clearances are even.

Frequency	Check for	Possible Causes	Possible Solutions
Every 3 months	Gear backlash.	Lack of lubrication. Excessive hydraulic loads. Loose gear locknuts.	Check lubrication level and frequency. Reduce hydraulic loads. Torque locknuts to specified torque values. See Table 15 on page 60. Check and replace gears if necessary.
Every 3 months	Worn or broken gear teeth.	Lack of lubrication. Excessive hydraulic loads. Loose gear locknuts.	Check lubrication level and frequency. Reduce hydraulic loads. Torque locknuts to specified torque values. See Table 15 on page 60. Check and replace gears if necessary.
Every 3 months	Loose gears.	Gear locknuts not torqued properly. Locking assembly not torqued properly. Worn gear key.	Torque gear nut to specified torque value. See Table 15 on page 60. Check and replace gears if necessary. Inspect gear key, shaft keyway and shaft, replace if necessary.
Every 3 months	Loose bearings, axially or radially.	Lack of lubrication. Excessive hydraulic loads. Product or water contamination.	Check lubrication level and frequency. Reduce hydraulic loads. Ensure no excess grease build-up. Replace bearings if necessary.

Cleaning

Determine the pump cleaning schedule on-site for materials being processed and plant maintenance schedule. For CIP models, see “CIP (Clean-In-Place) Features” on page 24.

To disassemble the fluid head, see “Fluid Head Disassembly” on page 34. Remove and clean the cover O-ring, pump seals, and the rotor nut assembly. Inspect and replace them as necessary.

NOTE: Always replace the rotor nut O-rings and rotor hub O-rings when reassembling the pump. If the area behind these seals becomes soiled, contact SPX FLOW Application Engineering for a specific cleaning and sanitizing procedure validated to remove bacteria. If a chlorine solution (200 ppm available chlorine) is used, it should leave no residual deposits which would remain in the pump.

CAUTION

Acid cleaners have a much higher metal corrosion rate and pump parts should remain in acid cleaning solutions no longer than necessary. Any strong inorganic mineral-based acids that are harmful to your hands would be harmful to pump parts. See “Stainless Steel Corrosion” on page 10.

In applications where material can harden in the pump during shutdown, a CIP cleaning, flush, or disassembly of the fluid head and manual cleaning is strongly recommended.

Fluid Head Disassembly

⚠ DANGER

The pump contains internal moving parts. DO NOT put hands or fingers into the pump body ports or drive area at any time during operation. To avoid serious injury, DO NOT install, clean, service, or repair the pump unless all power is off and locked out.

⚠ DANGER

To avoid serious injury, shut off and drain product from the pump prior to disconnecting the piping.

Remove Cover

1. Remove the cover nuts (Figure 33, item 11) from the cover (item 2). Using a soft hammer, tap the cover (item 2) off the body studs and dowel pins.
2. Place the cover on a protected surface with the finished surfaces facing up.

⚠ CAUTION

To lift the cover on a 210 or larger U2, attach an eye bolt to the threaded hole in the cover and attach lifting straps or chains to the eye bolt.

To lift the jacketed cover on an 045 or larger U2, attach an eye bolt to the threaded hole on the jacket and attached lifting straps or chains to the eye bolt.

1. Remove and inspect the cover O-ring (item 36).

Universal 2 Wrench Size	
Model	Cover Nut
006, 014, 015, 018	5/8"
030, 034, 040	
045, 060, 064, 130, 134	7/8"
180, 184, 220, 224	
210, 213, 214, 320, 323, 324, 370	1"

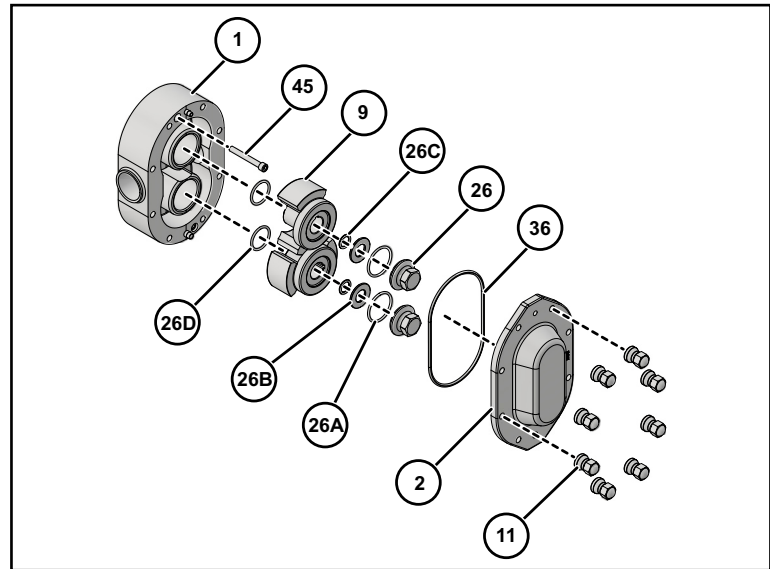

Figure 33 - Exploded View of Fluid Head

- | | |
|------------------------|------------------------------|
| 1. Body | 26B. Belleville-style washer |
| 2. Cover | 26C. Retainer O-ring |
| 9. Rotor | 26D. Rotor O-ring* |
| 11. Cover Nut | 36. Cover O-ring |
| 26. Rotor Nut | 45. Body Retaining Cap Screw |
| 26A. Rotor Nut O-ring* | |

* Discard the O-rings from the rotor and rotor nut; these are intended for one-time use only.

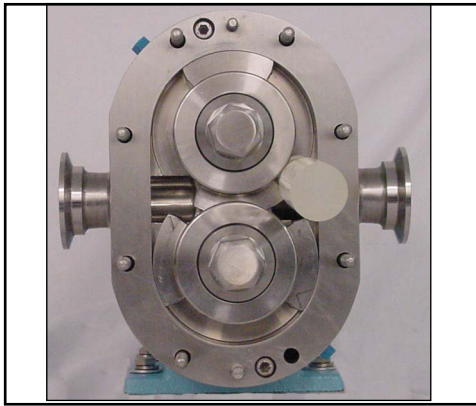

Figure 34 - Loosen Top Rotor

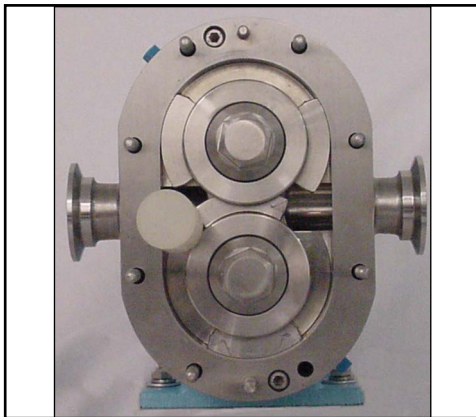

Figure 35 - Loosen Bottom Rotor

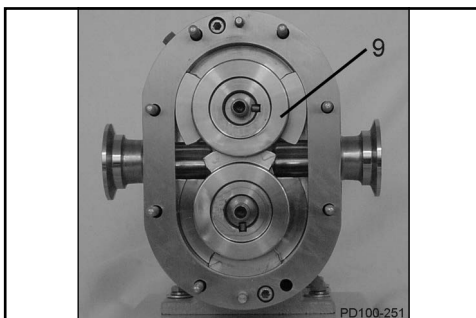

Figure 36 - Remove Overlapping Rotor First

Remove Rotor Nut Assemblies

1. Use the rotor blocking tool (part number 139790+) to keep the rotors from turning when removing the rotor nuts.

NOTE: When working on a rotor, always block the rotor against the body, not against the other rotor. See Figure 34 and Figure 35.

2. Using a wrench, remove the rotor nuts, belleville-style washers, rotor nut O-rings and rotor hub O-rings.

Table 5: Rotor Nut Wrench Size and Socket Tool

U2 Model	Wrench Size	Socket Tool
006, 014, 015, 018	15/16"	140074+
030, 034, 040	1-1/4"	139795+
045, 060, 064, 130, 134	1-5/8"	139796+
180, 184, 220, 224	2-1/4"	139797+
210, 213, 214, 320, 323, 324	2-3/8"	126536+

NOTE: SPX FLOW recommends using the Non-Marring Socket Tool for Rotor Nuts to protect the rotor nut. See Table 5 above and page 118.

Remove Rotors

1. Using only your hands, remove the rotor with the hub overlapping the other rotor wing (Figure 36, item 9).
2. Place the rotors in the up-turned cover to prevent damage to close-tolerance parts.

If the rotors cannot be removed by hand:

1. Use plastic or hardwood dowels to pry out the rotors.
2. Remove the body retaining cap screws. Tap the body forward and backward with a soft hammer to loosen the rotors.
3. If necessary, use a puller. Use care with the puller or dowels to avoid damaging the rotors.
4. Place the rotors in the up-turned cover to prevent damage to close-tolerance parts.

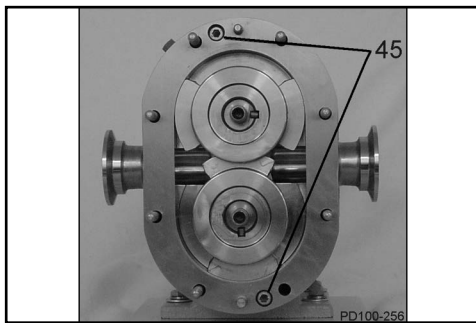

Figure 37 - Location of Cap Screws

Remove Pump Body

1. Remove the two body retaining cap screws (Figure 37, item 45).
2. Using a plastic mallet, tap the body off the gear case, dowel pins and body studs.
3. Slide the body straight off the body studs to prevent damaging mechanical seal parts.

⚠ CAUTION

To lift the body of a 130 or larger U2, use a lifting strap threaded through the ports on either side of the body.

4. Place the body on a protected surface with seals facing up to protect the seals.

Model	Body Retaining Cap Screw
006, 014, 015, 018	3/16"
030, 034, 040	
045, 060, 064, 130, 134	1/4"
180, 184, 220, 224	5/16"
210, 213, 214, 320, 323, 324, 370	

Remove Mechanical Seal

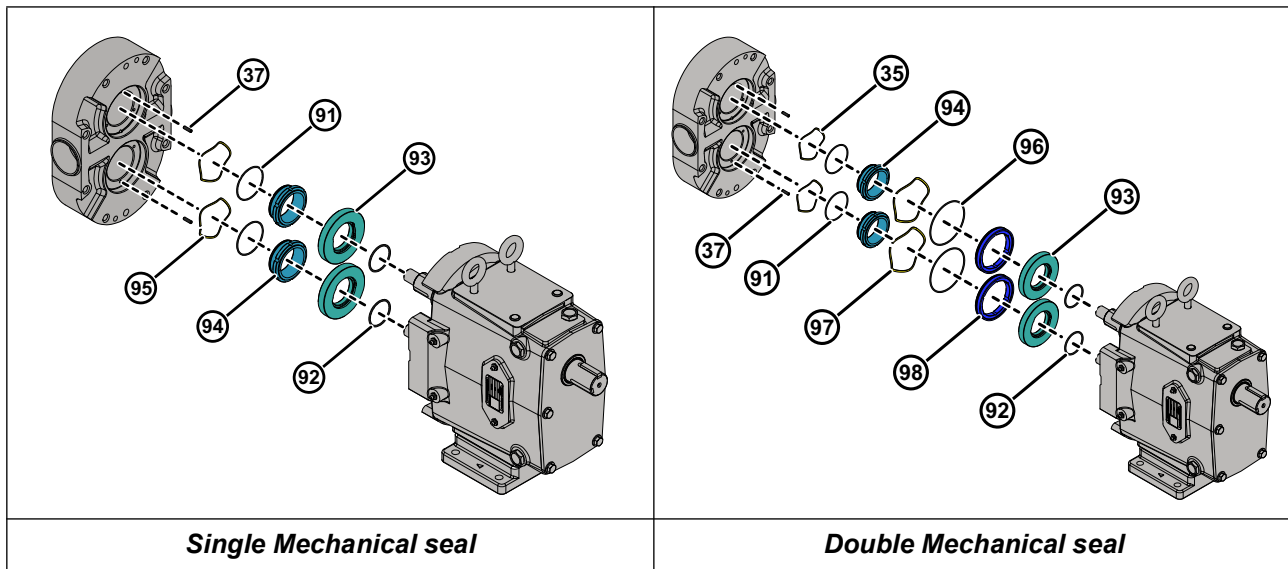

- 37. Stop Pin
- 91. Inner Seal O-ring
- 92. Shaft O-ring
- 93. Seal Seat
- 94. Inner Seal

- 95. Inner Wave Spring
- 96. Outer Seal O-ring
- 97. Outer Wave Spring
- 98. Outer Seal

Figure 38 - Mechanical seals

1. Remove the stationary seals from the pump body, using care not to damage the seals on the three body pins.

2. Remove the mechanical seal springs and O-rings on the stationary seals.
3. Inspect the three seal body pins for damage and repair or replace them as necessary. If the pins are loose, replace them with new ones.
4. Remove the rotary seal from each shaft. Use caution not to damage the seals during removal. Use a steady, even force behind the seal in multiple locations. After the rotary seals are removed, remove and replace the shaft O-rings. Before installing the new O-rings, inspect the shaft's O-ring groove(s) for damage and repair or replace them if required.
5. Inspect the flats on the shaft shoulder and repair or replace the shafts if required.

Gear Case Disassembly

⚠ DANGER

To avoid serious injury, DO NOT install, clean, service, or repair the pump unless all power is off and locked out.

⚠ DANGER

To avoid serious injury, shut off and drain product from the pump prior to disconnecting piping.

⚠ CAUTION

To lift the gear case assembly on pumps larger than 015-U2, attach lifting straps/chains to the two eye bolts on the top of the gear case.

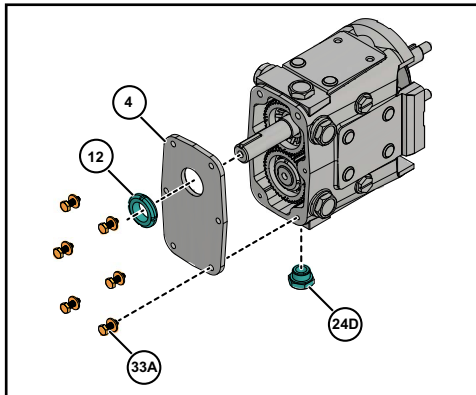

Figure 39 - Remove Gear Case Cover

Remove Gear Case Cover

1. Remove the oil drain plug (Figure 39, item 24D); drain the oil.
2. Remove the cap screws from the gear case (item 33A).
3. Pull the cover (item 4) off the shaft extension. If the cover sticks, use a soft hammer to loosen it.
4. Remove the silicone sealant (item 25) from the gear case and cover.
5. Using an arbor press, remove the oil seal (item 12) from the cover. Discard the used oil seal.

- 3. Gear Case
- 4. Gear Case Cover
- 12. Oil Seal
- 24D. Oil Drain Plug
- 24F. Oil Fill Plug
- 24L. Oil Level Check Plug, Sight Glass
- 25. Silicone Sealant
- 33A. Cap Screw

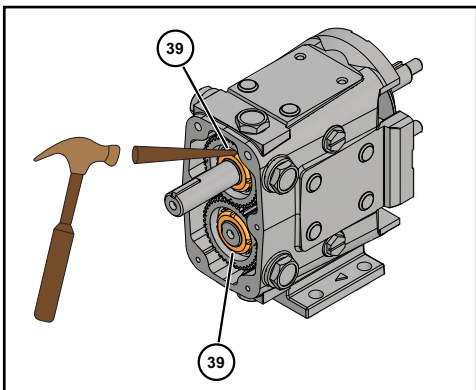
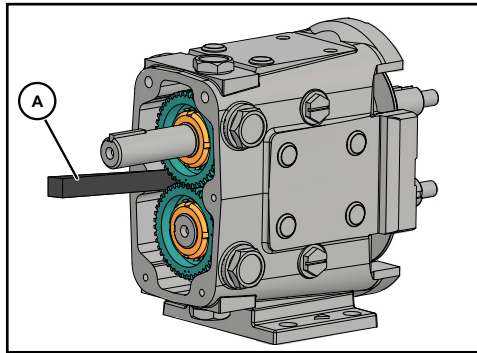

Figure 40 - Straighten Lock Tab

Remove Shaft

1. Straighten the tab on the lock washers (Figure 40, item 39).



- Prevent the shafts from turning by placing a wedge or soft dowel between the gears (Figure 41, item A). Use a gear nut driver tool (see below) to remove the gear locknut. The gears will be removed later.

Table 6: Gear Nut Driver Tool

U2 ND Model	Part Number
006, 014, 015, 018	109281+
030, 034, 040	109282+
045, 060, 064, 130, 134	109283+
180, 184, 220, 224	110304+
210, 213, 214, 320, 323, 324, 370	114702+

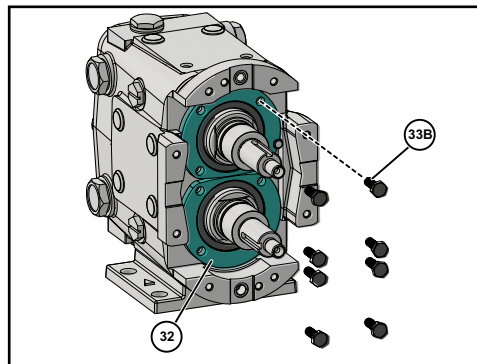

- Remove the front bearing retainer screws (Figure 41, item 33B) and pull off the bearing retainers (item 32). (If a retainer is stuck, leave it in place; it will press out when the shaft is removed.)

Figure 41 - Remove Bearing Retainers

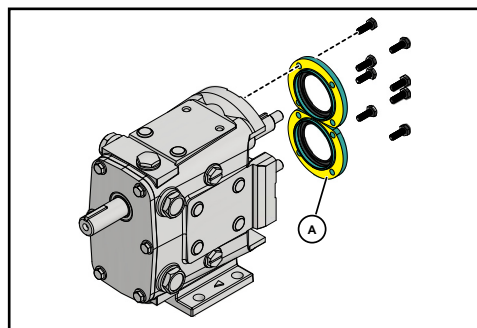

- Remove the silicone sealant (Figure 42, item A) from the bearing retainer and gear case.

NOTE: Protect the liquid end of the shafts by wrapping them with tape.

Figure 42 - Remove Sealant from Retainer

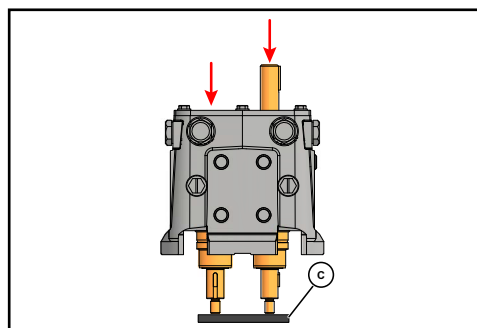

- Place the gear case on an arbor press with the liquid end facing down. Protect the shaft ends with a wood or plastic block (Figure 43, item C) and press the shafts out of the gear case.

CAUTION

To lift the gear case assembly on pumps larger than 015-U2, attach lifting straps/chains to the two eye bolts on the top of the gear case.

- Remove the gear spacers and gear keys from the shafts.
- Remove the gears from the gear case.

Figure 43 - Press Shafts from Gear Case

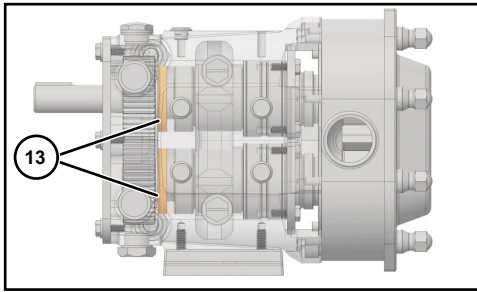

Figure 44 - Remove Rear Oil Seals

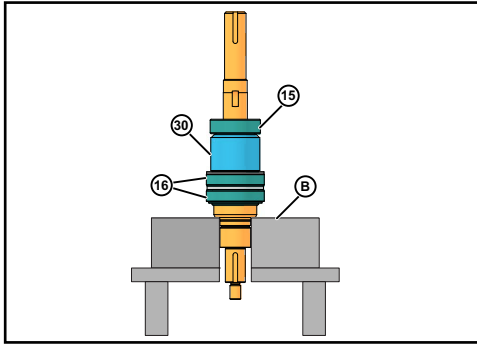

Figure 45 - Remove Bearings From Shaft

Shaft Assembly

NOTE: SPX FLOW now offers shaft assemblies with pressed-on bearings. See page 112.

8. Press out and discard the front bearing seals from the front bearing retainers. Clean and reuse the bearing isolators, if installed.
9. Remove the shims. If the shafts and bearings will be reused, identify the shims and bearings that belong with each shaft.
10. Press out and discard both rear oil seals in the gear case (Figure 44, item 13).

11. Use a hydraulic press and V-blocks (Figure 45, item B) to remove the bearings (items 15 and 16) and spacer (item 30)

NOTE: Make sure both ends of the shaft are protected when removing the shaft.

Front Bearing Assembly

SPX FLOW PD Precision Pumps require bearing assemblies with very tight internal tolerances. In fact, the internal tolerances of “off-the-shelf” bearings can be many times larger than required. Although they are considered in-spec in the bearing industry, they can cause internal damage within an SPX FLOW PD Pump.

SPX FLOW’s proprietary bearing “MATCHING” process starts with top quality bearing assemblies, then sorts, measures, pairs, grinds and adds spacers to them to ensure the matched bearing sets meet the required tight internal tolerances.

SPX FLOW bearings can be cross-referenced and appear to be the same, but competitive bearings are omitting the Matching process, which is imperative to achieve the required internal tolerances. Once a bearing set is matched, it must remain together as a set for the life of the pump, in order to maintain the tight internal tolerances.

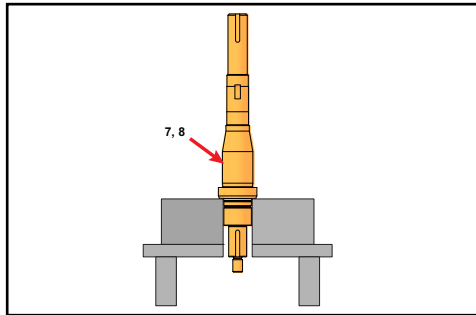

Figure 46 - Grease Shaft

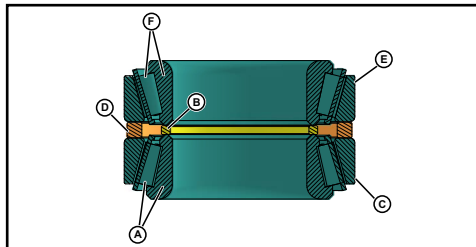

Figure 47 - Bearing assembly

- A. Lower Cone / Roller Assembly
- B. Inner Spacer
- C. Lower Cup
- D. Outer Spacer
- E. Upper Cup
- F. Upper Cone / Roller Assembly

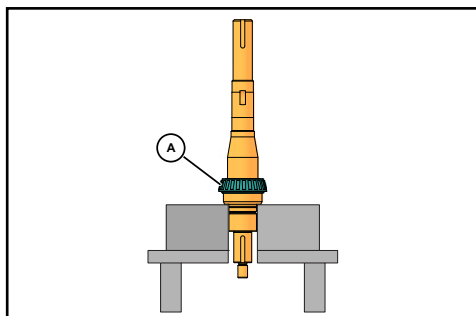

Figure 48 - Press Lower Cone onto Shaft

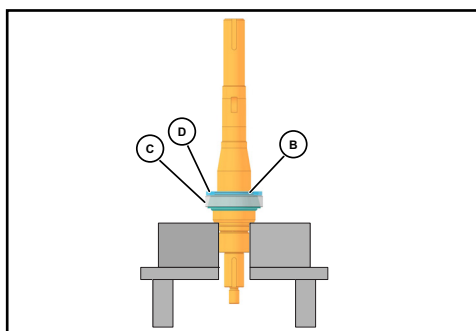

Figure 49 - Inner & Outer Spacer and Lower Cup

NOTE: The following instructions cover the assembly of a six-piece front bearing assembly. For a four-piece assembly, only one spacer and cup is used.

1. Lubricate the front bearing area of the shaft (Figure 46, item 7, 8) with oil or grease. Place it upright in a hydraulic press with the liquid end down.

2. Unwrap the front bearing assembly.

NOTE: DO NOT interchange the parts of one bearing assembly with another. The parts are precisely matched during manufacturing and must be installed as a matched assembly. See Figure 47.

3. Lift the lower cone and roller assembly (Figure 48, item A) out of the bearing stack and place it on the shaft with the radius facing down. Press it onto the shaft until it is seated against the shaft shoulder. **Press only on the inner cone.**

4. Place the inner spacer (Figure 49, item B) over the shaft onto the lower cone and roller assembly.
5. Place the lower cup (item C) over the lower cone and roller assembly, keeping the cup opening toward the assembly.
6. Place the outer spacer (item D) over the shaft and onto the lower cup.

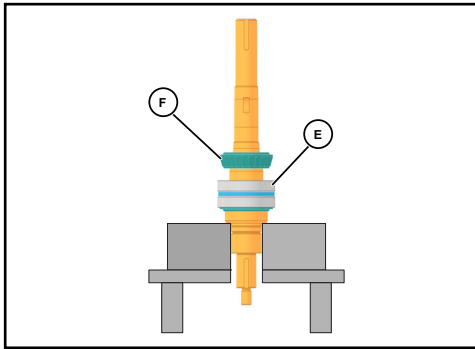

Figure 50 - Upper Cup & Upper Cone

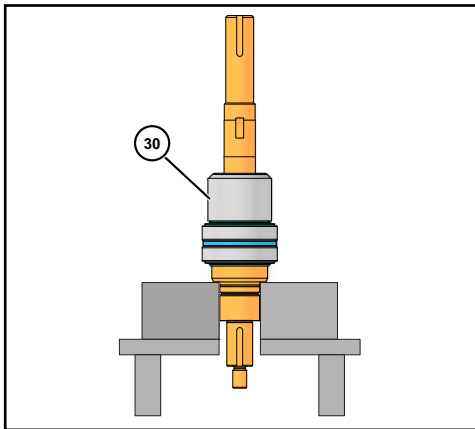

Figure 51 - Install Bearing Spacer

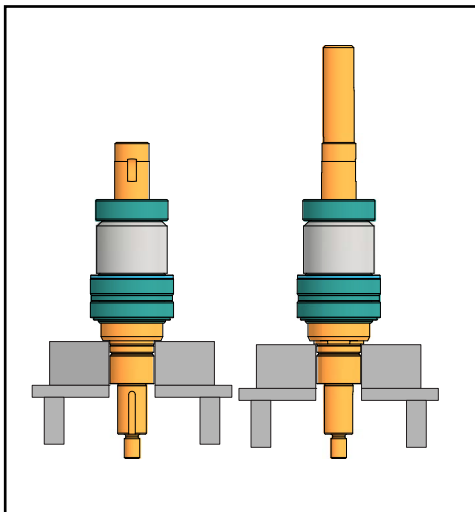

Figure 52 - Rear Bearing Assembly

7. Place the upper cup (Figure 50, item E) on top of the outer spacer.
8. Lubricate the remaining upper cone and roller assembly (Figure 50, item F) with oil or grease and slip it over the shaft with the roller radius facing up. Press it onto the shaft and into the upper cup.

NOTE: Make sure all components are aligned before pressing. Press only on the inner cone.

9. Install the bearing spacer (Figure 51, item 30).

Rear Bearing Assembly

Models 006, 014, 015, 018, 030, 034 and 040 use a single ball bearing assembly for the rear bearing. All other models use a tapered roller bearing assembly similar to the front bearings.

NOTE: PD Pump shaft assemblies with pressed-on bearings are available. See page 112.

1. Unwrap the rear bearing assembly.

NOTE: DO NOT interchange the parts of one bearing assembly with another. These parts are precisely matched during manufacturing and must be installed as a matched assembly.

- **For models with ball bearing assemblies:** Lubricate the shaft inner bearing race with oil or grease. Press the bearing into place. The shielded side of the bearing fits against the bearing spacer. Press only on the inner race.
- **For models with tapered roller bearing assemblies:** Lubricate the shaft bearing area with oil or grease. Follow the "Front Bearing Assembly" procedures 40.

NOTE: Heating the bearings is **NOT** recommended. If bearings are heated, do not exceed 300°F (149°C).

Gear Case Assembly

⚠ CAUTION

To lift the gear case assembly on pumps larger than 015-U2, attach lifting straps/chains to the two eye bolts on the top of the gear case.

Suggested Shims			
U2 Model	Standard Shaft in (mm)	Replacement Shaft in (mm)	Shim kit
006, 014, 015, 018	.113 (2.87)	.110 (2.79)	117889+
030, 034, 040	.105 (2.27)	.102 (2.59)	117890+
045, 060, 064, 130, 134	.093 (2.36)	.088 (2.24)	117891+
180, 184, 220, 224	.115 (2.92)	.110 (2.79)	117892+
210, 213, 214, 320, 324, 370	.125 (3.18)	.120 (3.05)	117893+

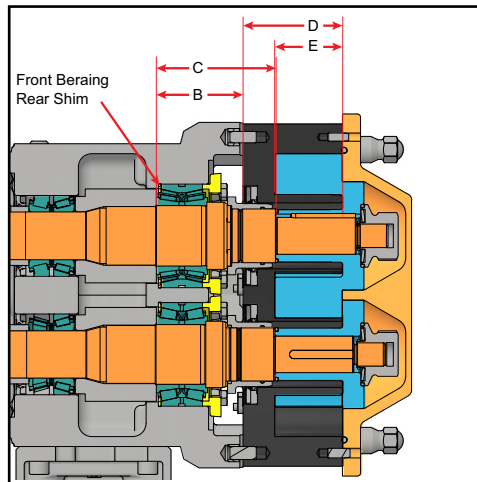

Figure 53 - Measure B, C, D and E

Shimming

- When installing the shafts in the gear case, shim behind the front bearing to achieve the proper backface clearance between the back of the rotors and the body. The backface clearance must be equal for both rotors to prevent the rotors from hitting each other during operation.

NOTE: Do not install bearing retainer sealant, gears, or gear locknuts until the correct shimming has been verified.

- If the shafts and/or bearings do not need to be replaced and the shims are marked indicating the shaft and bearing they are matched with, a shim adjustment probably will not be necessary. Reuse the existing tagged shims, shafts and bearings in the same gear case bores.
- If existing shims are lost and/or a standard shaft is used, determine the required shims from the chart.
- If it is necessary to calculate the required shims for replacement shafts, bearings or both, refer to Figure 53; carry measurements and calculations to three decimal places (e.g., .059).

NOTE: Arrange with thicker shims on outside of the shim pack.

- Determine the shim thickness required for the front bearing:
 - Measure "B" in the gear case and "C" on the shaft (Figure 53).
 - Measure "D" and "E" on the body (Figure 53).
 - Determine the proper backface clearance. Refer to Table 8, "Rotor Clearances," on page 47.
 - Required Shims = Backface clearance - C + B + D - E.
- Place the shims in the gear case, resting against the shoulder in the front bearing bore.

(Callouts for both Figure 53)

- B. Front face of gear case to back of bearing bore
- C. Shaft shoulder to back of bearing race
- D. Body thickness
- E. Depth of rotor cavity

Install Shaft

1. With the shims in place, install the shaft assembly in the front bearing bore with the fluid end facing up. Ensure that the shaft is installed in its original location.

NOTE: The shafts may need to be removed for a final shim adjustment.

2. Lubricate the outside diameter of the bearing.
3. Press the shaft into place until it is seated against the shim pack. **Press only against the outer race of the bearing.**

NOTE: A tube of the same diameter as the outer race of the bearing also can be used to press the shaft into place.

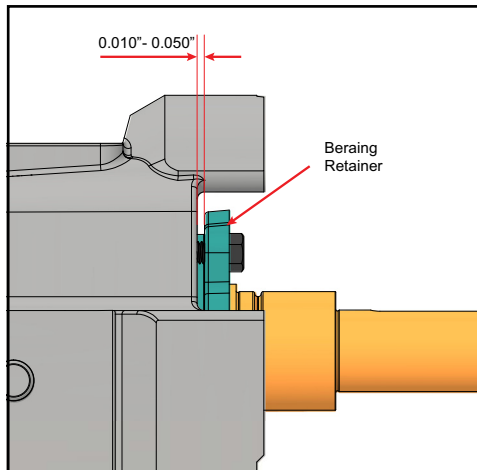

Figure 54 - Bearing Retainer Clearance

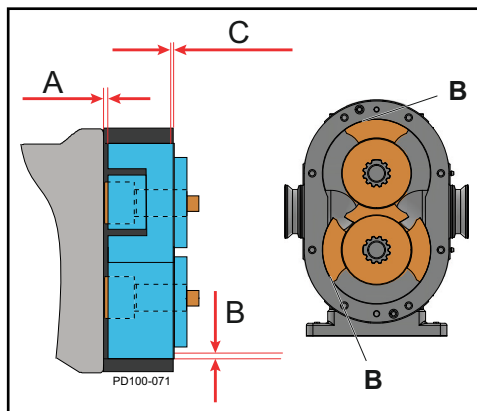

Figure 55 - Measure Clearance

NOTE: "B" dimension is below the face of the casing.

4. Temporarily secure the shaft/bearing in place with bearing retainers to aid in checking the clearances. **DO NOT** install silicone sealant at this time.
 5. The bearing retainer must rest firmly against the bearing. Leave a .010 to .050 in (.25 to 1.25 mm) clearance between the back of the bearing retainer and the front of the gear case (Figure 54). If this clearance is not met, place shims between the bearing and retainer.
 6. Temporarily mount the body on the gear case.
 7. Secure the body to the gear case using the body retaining screws.
 8. Install the rotors and rotor nuts. Rotor nut O-rings, belleville-style washers and retainer O-rings are not required at this time.
 9. Measure the rotor backface clearance (Figure 55, item A) through the port or from the front. The backface clearance for both rotors must be the same to prevent rotor crossover contact and must be ± 0.0005 " of the value found in Table 8, "Rotor Clearances," on page 47.
 10. Check the rotor front face clearance (Figure 55, item C).
 11. Check the rotor to body clearance (Figure 55, item B).
 12. Check the clearances against Table 8, "Rotor Clearances," on page 47. For other non-standard rotors, check with customer service.
- NOTE:** If the process uses special clearance rotors, contact customer service with the serial number of the pump for clearance tolerance values.
13. If the backface clearance is not met, disassemble the pump and adjust the shimming to achieve the correct backface clearance.
 14. If the rotor to body clearance is not met or is uneven, contact SPX FLOW Application Engineering for proper adjustment procedures.
 15. After obtaining proper clearance, remove the rotor nuts, rotors, body, and bearing retainers.

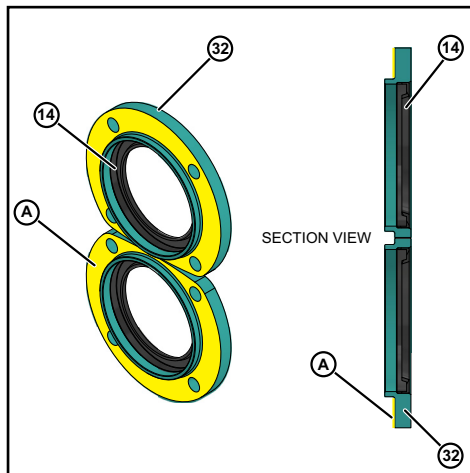

Figure 56 - Install Bearing Retainer

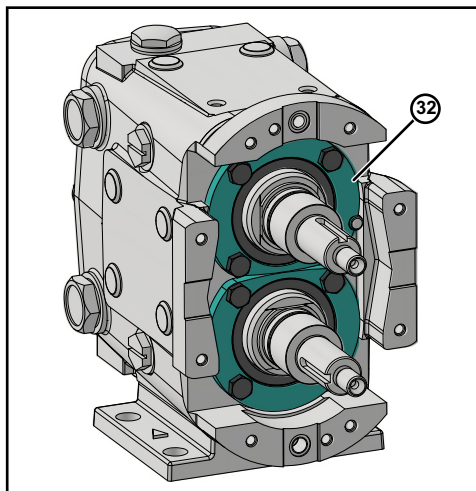

Figure 57 - Install Bearing Retainer

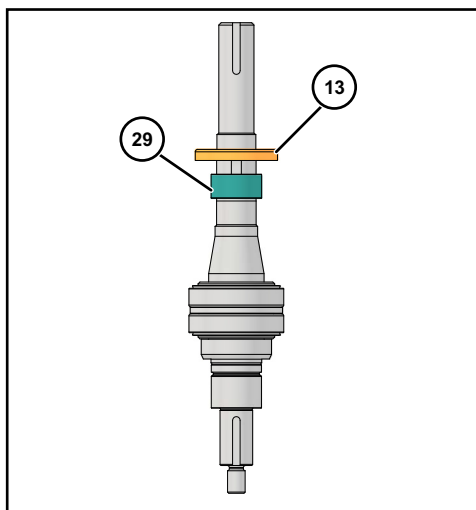

Figure 58 - Install Rear Seal

16. Grease the front and rear bearing through the grease fittings until grease is visible around the bearing assemblies. The amount of grease required is listed in “Grease Quantity (per Bearing)” on page 29. Rotate the shafts while greasing to disperse the grease.

17. Lubricate the seal lips and install the grease seals in the bearing retainers (compression spring on inside).

18. Coat the retainer flanges with silicone sealant (Figure 56, item A). (Gore-Tex® sealing tape can be used on silicone free models.) The grease seal (item 14) will be flush with the front of the bearing retainer. On 030 models, the grease seal will be against the step on the inside diameter of the retainer.

19. Install the bearing retainers (Figure 56, item 32).

Install Rear Seal Assembly

NOTE: Place tape or other material over the shaft end to prevent cutting the seal during installation.

1. Install the gear spacers (Figure 58, item 29).
2. Lubricate the inside and outside diameters of the oil seals with oil or grease.
3. Install the oil seals with the spring facing out (Figure 58, item 13).

Install Timing Gears

1. Place the gear keys into the shaft key slots. Angle the keys out for easier installation of the gears.

NOTE: To aid in timing setup, rotate the rotors until they are at right angles to each other before installing the gears.

2. Slide the spur drive gear onto the drive shaft. The spur drive gear has one punch mark on the gear.
3. Slide the short shaft gear onto the short shaft. The short shaft gear has two punch marks on the gear. Straddle the single punch mark of the spur drive gear with the two punch marks on the short shaft gear (Figure 59).

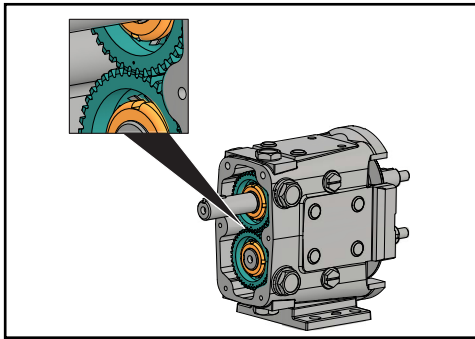

Figure 59 - Timing Gear Marks

4. Use a wood or nylon block (Figure 60, item A) to keep the shafts from turning. If a block is not available, use rags to block the gears, or with one rotor on the shaft, block the rotor with a nylon dowel.
5. Slide the lock washers onto the shaft. Lubricate the threaded area on the shafts and face of the locknuts with oil or grease.

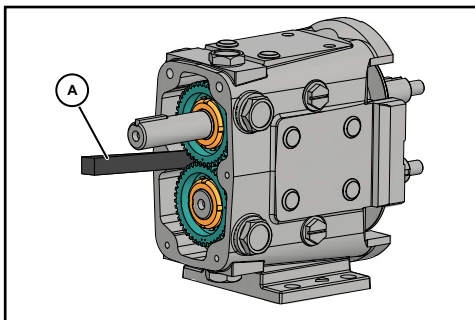

Figure 60 - Block Shaft Rotation

6. Tighten the gear locknuts to the specified torque, using a gear nut driver tool.

Table 7: Torque Values and Gear Nut Driver Tool

Model U2 Pumps	Gear Nut Torque	Tool Part No.
006, 015, 018	120 ft-lb(163 N·m)	109281+
030, 040		109282+
045, 060, 130	140 ft-lb (190 N·m)	109283+
180, 220	230 ft-lb (312 N·m)	110304+
210, 213, 320, 323, 370	320 ft-lb (434 N·m)	114702+

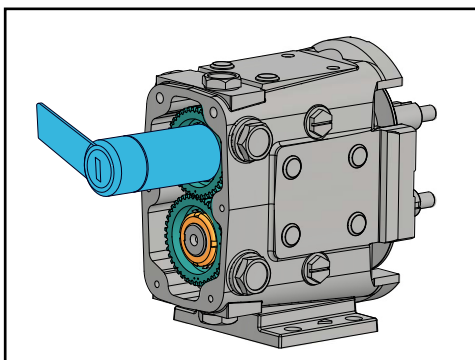

Figure 61 - Install Gear Locknuts

7. Bend the locking tab on the lock washers into the locking nut slots, securing the gear locknut into place (Figure 62).

Checking for Proper Clearance

Waukesha Cherry-Burrell brand pumps are designed with close running clearances. Backface clearances are set with shims during assembly.

Shafts are positioned with shims behind the front bearing and locked into gear case with the bearing retainers. Rotors lock against the shaft shoulder. Clearance between the body backface and the back of the rotor wing is called backface clearance.

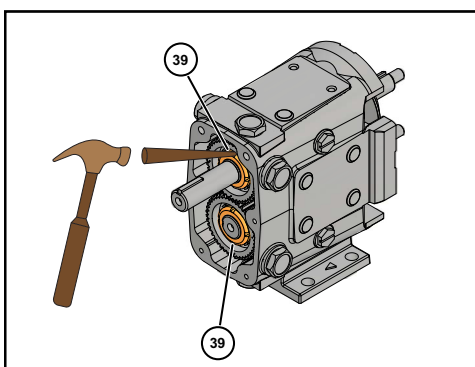

Figure 62 - Bend Lock Tab on Lock washers

NOTE: It is generally best to keep backface clearance to a minimum.

CAUTION

Backface clearance for both rotors must be equal to avoid crossover interference with the adjacent rotor hub.

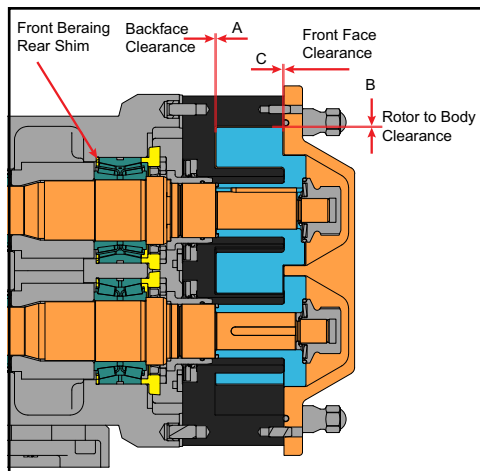

Figure 63 - Clearance Measurements

1. To check backface clearance, first mount the body (less seals) onto the housing. Assemble the rotors and secure them with rotor jam nuts.
2. With feeler gauges, measure the rotor backface clearance (Figure 63, item A), through the port or from the front.
3. Measure the rotor front face clearance (Figure 63, item C).
4. Measure the rotor to body clearance (Figure 63, item B).
5. Check the measured clearances against Table 8, “Rotor Clearances,” on page 47.
6. Make corrections as required and follow examples in Table 9, “Backface Clearance Corrections,” to determine the exact adjustment to make and to avoid unnecessary assembly/disassembly.
7. To make shim adjustments, first remove the rotors, body and shafts. Make the required shim adjustment and reassemble.
8. Re-check the backface clearances. Be sure both rotors have the same clearance to avoid crossover interference with the adjacent rotor hub.

Table 8: Rotor Clearances

Universal 2 Model	A - Backface in (mm)		B - Rotor to Body in (mm)		C - Front Face in (mm)	
	Std & FF	Hot	Std & FF	Hot	Standard	FF & Hot
006	0.0015 - 0.002 (0.04 - 0.05)	0.0015 - 0.002 (0.04 - 0.05)	0.001 - 0.004 (0.03 - 0.10)	0.0025 - 0.0055 (0.06 - 0.14)	0.004 - 0.006 (0.10 - 0.15)	0.0055 - 0.0075 (0.14 - 0.19)
014, 015, 018	0.0015 - 0.002 (0.04 - 0.05)	0.0015 - 0.002 (0.04 - 0.05)	0.001 - 0.004 (0.03 - 0.10)	0.0025 - 0.0055 (0.06 - 0.14)	0.004 - 0.0065 (0.10 - 0.17)	0.006 - 0.0085 (0.15 - 0.22)
030, 034, 040	0.002 - 0.0025 (0.05 - 0.06)	0.002 - 0.0025 (0.05 - 0.06)	0.001 - 0.005 (0.03 - 0.13)	0.0025 - 0.006 (0.06 - 0.15)	0.0035 - 0.006 (0.09 - 0.15)	0.0065 - 0.009 (0.17 - 0.23)
045, 060, 064	0.003 - 0.0035 (0.08 - 0.09)	0.003 - 0.0035 (0.08 - 0.09)	0.003 - 0.0075 (0.08 - 0.19)	0.005 - 0.010 (0.13 - 0.25)	0.0045 - 0.009 (0.11 - 0.23)	0.0085 - 0.014 (0.22 - 0.36)
130, 134	0.003 - 0.0035 (0.08 - 0.09)	0.003 - 0.0035 (0.08 - 0.09)	0.0035 - 0.0075 (0.09 - 0.19)	0.0055 - 0.0095 (0.14 - 0.24)	0.0045 - 0.009 (0.11 - 0.23)	0.009 - 0.015 (0.23 - 0.38)
180, 184, 220, 224	0.004 - 0.005 (0.10 - 0.13)	0.004 - 0.005 (0.10 - 0.13)	0.0055 - 0.0095 (0.14 - 0.24)	0.009 - 0.013 (0.23 - 0.33)	0.005 - 0.010 (0.13 - 0.25)	0.010 - 0.015 (0.25 - 0.38)
210, 213, 214, 320, 323, 324	0.005 - 0.006 (0.13 - 0.15)	0.005 - 0.006 (0.13 - 0.15)	0.008 - 0.012 (0.20 - 0.30)	0.010 - 0.014 (0.25 - 0.36)	0.007 - 0.012 (0.18 - 0.30)	0.013 - 0.018 (0.33 - 0.46)
370	0.005 - 0.006 (0.13 - 0.15)	0.005 - 0.006 (0.13 - 0.15)	0.009 - 0.013 (0.23 - 0.33)	0.011 - 0.015 (0.28 - 0.38)	0.007 - 0.012 (0.18 - 0.30)	0.013 - 0.018 (0.33 - 0.46)

Rotor Styles: Std. = Standard Clearance, FF = Front Face Clearance, Hot = Hot Clearance

See “Rotor Styles” on page 14 for descriptions; see page 12 for operating temperatures.

Table 9: Backface Clearance Corrections

Problem	Condition	Correction
Too Much Backface Clearance (A)	Dimension A is greater than the value in Table 8.	A (measured) minus Column A (Table 8) = shims to remove from the rear outer race of the front bearing
	Rotor wing face projects past the body front face	C (measured with depth micrometer) plus C (Table 8) = shims to remove from the rear of the front bearing
Not Enough Backface Clearance (A)	Dimension A is less than the value in Table 8.	Column A (Table 8) minus A (measured) = shims to add to the rear outer race of the front bearing

NOTE: If the clearance corrections in Table 9 have been performed and desired performance is not achieved, contact SPX FLOW technical services for guidance.

Install Gear Case Cover

1. Lubricate the inside diameter of a new oil seal (3).
2. Press the new oil seal (3) into the gear case cover (4) flush with the outside face, with the spring facing in.
3. Apply silicone sealant (A) to the back of the gear case (5). (Gore-Tex® sealing tape can be used on silicone-free models.) Place tape on the inside of the screw holes.
4. Tape the shaft end to prevent cutting the seal on the keyway. Mount the cover assembly on the gear case. Secure it with cap screws (1) and washers (2).
5. Remove the tape from the shaft end.

NOTE: Make sure that the shaft is centered in the lip seal before securing the cap screws.

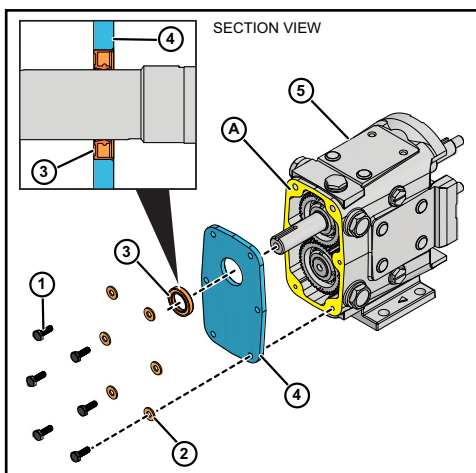

Figure 64 - Install Cover Lip Seal and Cover

6. Install the oil drain plug (1).
7. Fill the gear case with gear oil to the proper level. Refer to "Lubrication" on page 29.

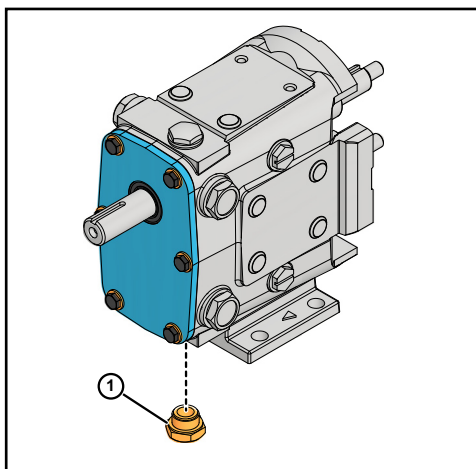
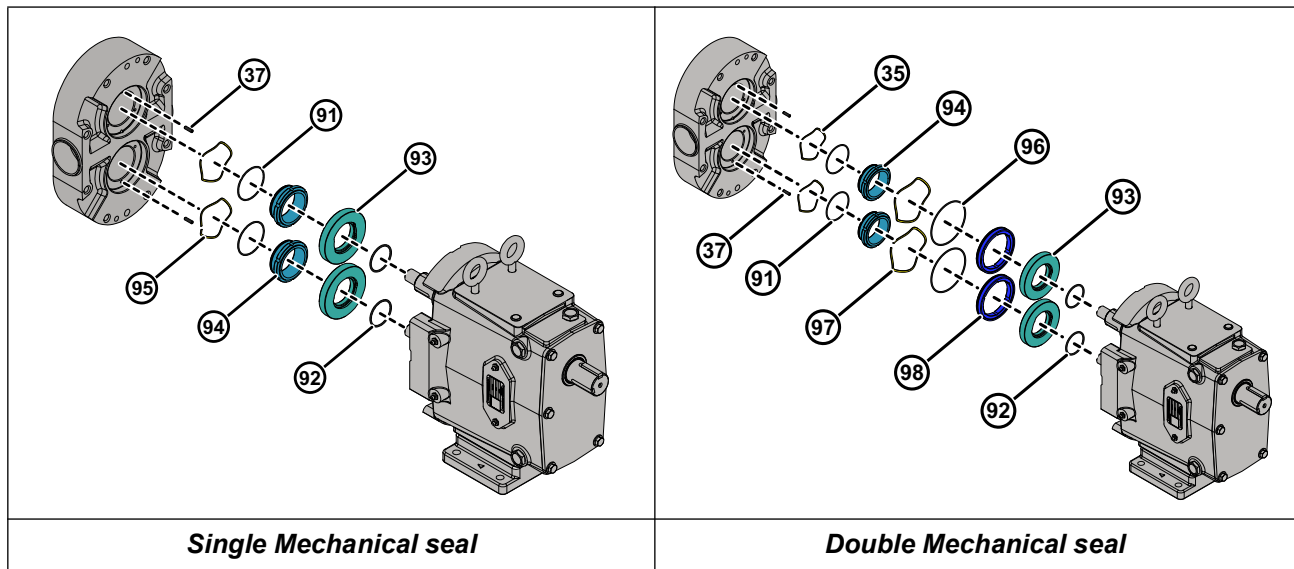

Figure 65 - Install Oil drain Plug

Fluid Head Assembly

Install Mechanical Seal



37. Stop Pin
91. Inner Seal O-ring
92. Shaft O-ring
93. Seal Seat
94. Inner Seal

95. Inner Wave Spring
96. Outer Seal O-ring
97. Outer Wave Spring
98. Outer Seal

Figure 66 - Mechanical seals

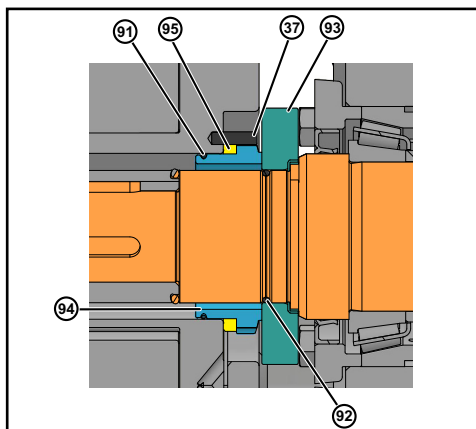

Figure 67 - Single Mechanical Seal

1. Lubricate the shaft O-ring (Figure 67, item 92) with a lubrication compound compatible with the O-ring material and process fluid(s). Place the O-ring on the shaft.
2. Install the rotating seal seat (item 93) on the shaft. Align the drive flats on the seat with the drive flats on the shaft.
3. Push the seat squarely against the shaft shoulder.
4. Install the inner wave spring (item 95) onto the inner seal (item 94).
5. Lubricate the inner seal O-ring (item 91) with a lubrication compound compatible with the O-ring material and process fluid(s). Install the inner seal O-ring into the groove of the inner seal.

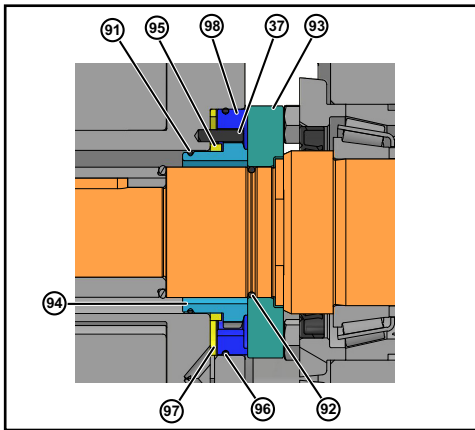

Figure 68 - Double Mechanical Seal

6. Place the inner seal into the back of the pump body. Ensure that the notches are aligned in the inner seal with the stop pins in the body. Press firmly and evenly into place.
7. If a double mechanical seal is used, install the outer wave spring (Figure 68, item 97) in the body and the outer O-ring (item 96) in the outer seal groove (item 98). Place the outer seal in the pump body around the inner seal, aligning the notches in the outer seal with the stop pins in the body.
8. Inspect the seal faces for cleanliness. Ensure that the faces have no nicks or scratches. Lubricate the seal faces with a lubricant compatible with the process fluid(s).
9. Perform steps 1 through 5 on both shafts.

Install Pump Body

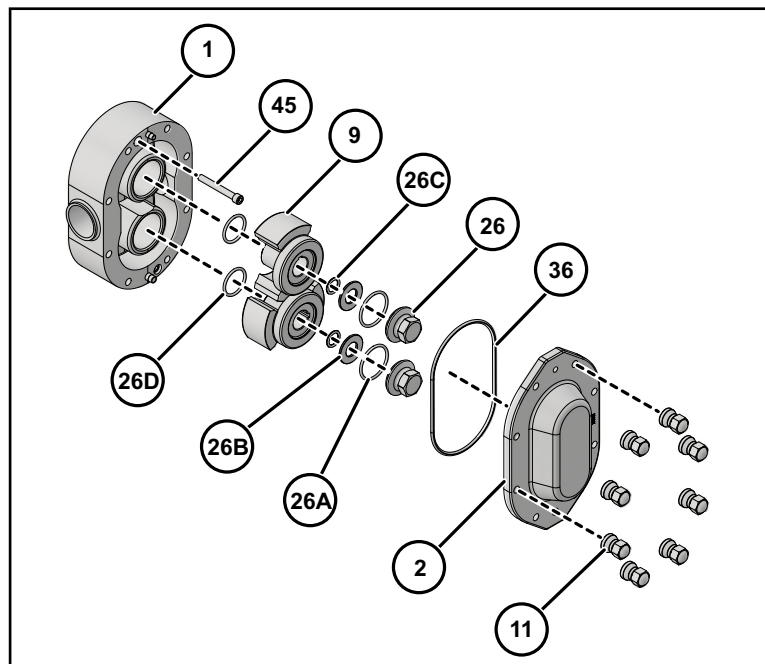

Figure 69 - Exploded View of Fluid Head

- | | |
|------------------------|------------------------------|
| 1. Body | 26B. Belleville-style Washer |
| 2. Cover | 26C. Retainer O-ring |
| 9. Rotor | 26D. Rotor Hub O-ring* |
| 11. Cover Nut | 26E. Rotor Key |
| 26. Rotor Nut | 36. Cover O-ring |
| 26A. Rotor Nut O-ring* | 45. Body Retaining Cap Screw |

* Discard rotor nut and rotor hub O-rings; these are one-time use only.

CAUTION

To lift the body of a 130 or larger U2, use a lifting strap threaded through the ports on either side of the body.

1. Match the large and small dowel pin sizes on the pump body with the dowel pin holes in the pump gear case.
2. Install the body (Figure 69, item 1) to the gear case assembly, aligning the body with the body studs. Avoid damaging the seals as the body is drawn over the shafts.
3. Secure the body to the gear case using two cap screws (Figure 69, item 45).

Install Rotors

1. Lubricate the rotor hub O-ring (Figure 69, item 26D) with a lubrication compound compatible with the O-ring material and process fluid(s).
2. Install new rotor hub O-rings (item 26D) into the groove on the rotor hubs.
3. Install the rotors (item 9) onto the shafts.
4. Align the keyways in the rotors with the keyways on the shafts and install the keys (item 26E).

NOTE: For rotor nut assembly detail, including orientation of the belleville-style washer (item 26B), see Figure 70 and Figure 71 on page 51.

Install Rotor Nut Assemblies

See Figure 69 on page 50, and Figure 70 and Figure 71 on this page.

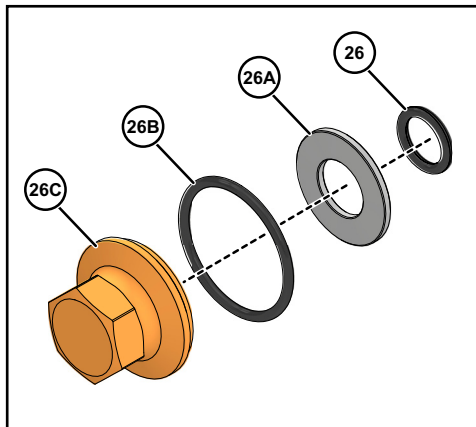

Figure 70 - Rotor Nut Assembly

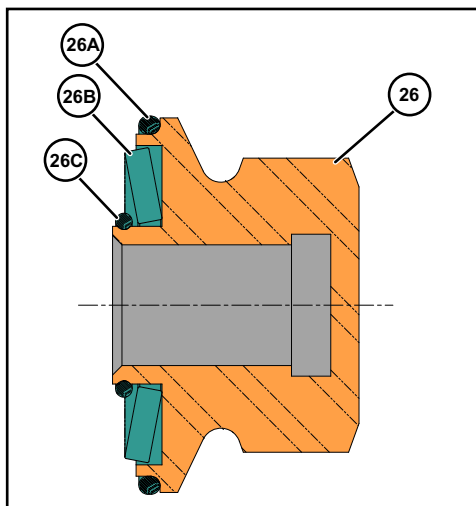

Figure 71 - Cross-Section View of Rotor Nut Assembly, as Assembled

1. Install a belleville-style washer (item 26B) into the rotor nut (26) with the raised side of the washer facing **toward** the rotor nut.
2. Place the retainer O-ring (item 26C) into the rotor nut to retain the belleville-style washer. The washer should **not** be tight against the O-ring.
3. Lubricate a new rotor nut O-ring (item 26A) with a lubrication compound compatible with the O-ring material and process fluid(s). If the O-ring is not lubricated, it will pucker when tightening the rotor nut.
4. Install the rotor nut O-ring onto the rotor nut.
5. Prior to assembling the rotor nuts, apply an anti-seize compound to the shaft threads.
6. Use the rotor blocking tool (part number 139790+) to prevent the rotors from turning during installation.

NOTE: Always block the rotor against the body, not against the other rotor.

NOTE: SPX FLOW recommends using the Non-Marring Socket Tool for Rotor Nuts to protect the rotor nut when torquing.

7. Screw the rotor nuts (item 26) onto the shafts (clockwise) and tighten them to the required torque.

Table 10: Rotor Nut Wrench Size and Socket Tool

U2 Model	Wrench Size	Socket Tool
006, 014, 015, 018	15/16"	126533+
030, 0034, 40	1-1/4"	139795+
045, 060, 064, 130, 134	1-5/8"	139796+
180, 184, 220, 224	2-1/4"	139797+
210, 213, 214, 320, 323, 324, 370	2-3/8"	126536+

⚠ CAUTION

Failure to tighten the cover nuts to the proper torque (see Table 12) could cause the body studs to fail prematurely under high pressure.

⚠ CAUTION

To lift the cover on a 210 or larger U2, attach an eye bolt to the threaded hole in the cover and attach lifting straps or chains to the eye bolt.

To lift the jacketed cover on an 045 or larger U2, attach an eye bolt to the threaded hole on the jacket and attached lifting straps or chains to the eye bolt.

Table 12: Cover Nut Torque

U2 Model	Cover Nut Torque
006, 014, 015, 018	7 ft-lb (10 N·m)
030, 034, 040	11 ft-lb (15 N·m)
045, 060, 064	56 ft-lb (76 N·m)
130, 134	25 ft-lb (34 N·m)
180, 184, 220, 224	110 ft-lb (149 N·m)
210, 213, 214, 320, 323, 324, 370	158 ft-lb (214 N·m)

⚠ CAUTION

Use a torque wrench to tighten the rotor nuts to the proper torque. (See Tables 10 and 11 for wrench sizes and torque values.) Failure to tighten the nuts properly could result in the nuts loosening during operation, causing damage to the pump.

Table 11: Rotor Nut Torque

U2 Model	Rotor Nut Torque
006, 015, 018	50 ft-lb (68 N·m)
030, 040	120 ft-lb (163 N·m)
045, 060, 130	250 ft-lb (339 N·m)
180, 220	325 ft-lb (441 N·m)
210, 213, 320, 323, 370	375 ft-lb (508 N·m)

Install Cover

1. Clean the cover O-ring (See Figure 69 on page 50, item 36) and install it in the groove in the cover.
2. Match the large and small dowel pin sizes on the pump body with the dowel pin holes in the cover.
3. Install the cover (See Figure 69 on page 50, item 2) on the pump body.
4. Prior to assembling the cover nuts, apply an anti-seize compound compatible with the product to the threads of the body studs.
5. Tighten the cover securely using the cover nuts (See Figure 69 on page 50, item 11) and Table 12.

⚠ CAUTION

If a double seal arrangement is used, the seals must be provided with a clean, compatible barrier fluid. Make certain that the flush ports in the pump body are clean and clear.

Relief Cover Option (Vented Cover)

The optional Relief Cover Feature (also called Vented Cover) is an adjustable, internal by-pass arrangement which can be used for control of the pressure and/or flow. It is bidirectional; that is, the pump flow or rotation can be in either direction.

CAUTION

SPX FLOW does not recommend using a vented cover on liquids with a viscosity of over 5000 cPs.

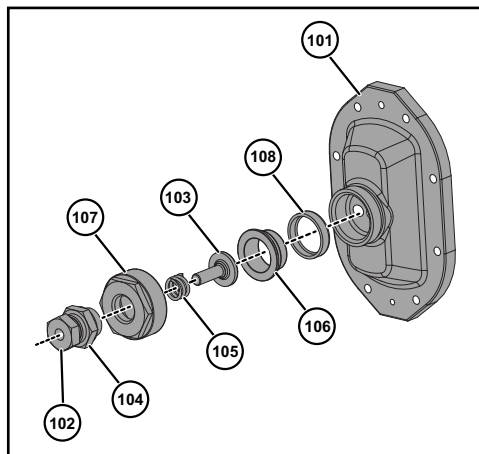

Figure 72 - Manual Cover

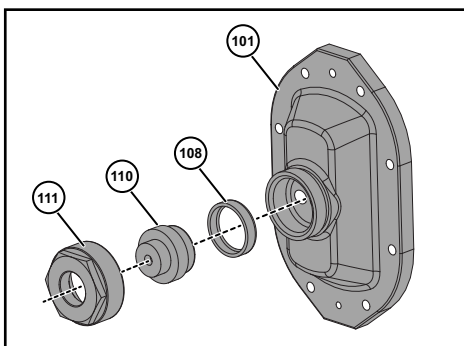

Figure 73 - Pneumatic Diaphragm Cover

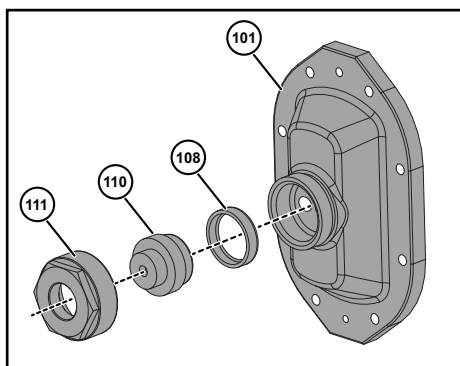

Figure 74 - Pneumatic Piston Cover

This option does not provide full flow relief for all pumping situations.

The pressure downstream of the pump may increase with increasing amount of by-pass through the Relief Cover. Actual downstream pressure will depend on the pump speed, product viscosity, and the relief set point (spring adjustment or air pressure). Avoid high flow rates through the cover with high viscosity products. The resulting pressure may be greater than the maximum rating of the pump or other system components. Install a pressure gauge and measure the pressure under the worst conditions of maximum flow and maximum viscosity to determine the maximum pressure for your process. **Under any conditions, if there is a complete flow shut off downstream, stop the pump as soon as possible.** Continued pump operation with the entire flow by-passing will rapidly build heat within the pump body. Contact SPX FLOW Application Engineering for assistance.

NOTE: The vented cover is not CIP-able. It must be manually disassembled for cleaning.

Three types of Relief Covers are available:

Manual

By-pass pressure is adjusted by a threaded adjusting screw (102) which compresses a spring (105). Several spring sizes are available, to cover a range of operating pressures.

Pneumatic Diaphragm

By-pass pressure is adjusted by regulated air or gas pressure, operating on the side of a diaphragm (108) opposite the pumped fluid.

Pneumatic Piston

By-pass pressure is adjusted by regulated air or gas pressure, operating on the side of a metal piston (112), opposite the pumped fluid. An extended pressure range is possible.

NOTE: On all types of relief covers, the temperature and chemical resistance of the elastomer diaphragms and O-rings determine the useful range: Buna-N (material supplied as standard) and Silicone Rubber (optional material upon request)

Installation Adjustment

Manual

Turn the adjusting screw counterclockwise to its farthest position, then clockwise until a light spring pressure is felt.

Pneumatic Diaphragm

1. Set air/gas pressure to 2-5 psig.
2. Turn on the pump.
3. With the pressure gauge and valve in the discharge line:
 - Close the discharge valve.
 - Turn the adjusting screw clockwise until the desired relief pressure registers on the gauge. Lock the adjusting screw with a lock nut.
 - Open the valve in the discharge line. The relief cover is set and will open if the system pressure exceeds the preset limit.
4. Without a pressure gauge in the discharge line:
 - Turn the adjusting screw clockwise and observe the product flow at the discharge of the system.
5. When the product flow reaches the maximum or desired flow rate, lock the adjusting screw with a lock nut.

Pneumatic Piston

1. With a pressure gauge and valve in the discharge line:
 - Close the discharge valve slowly and observe the gauge pressure. **DO NOT ALLOW PRESSURE TO EXCEED 200 psi.**
 - Increase the air/gas pressure, until the desired relief pressure registers on the gauge. Lock the air/gas pressure regulator adjusting screw with a lock nut.
 - Open the valve in the discharge line. The relief cover is set and will open if the system pressure exceeds the preset limit.
2. Without a pressure gauge in the discharge line:
 - With a regulator, increase the air/gas pressure to the relief valve and observe the product flow at the discharge of the system.
3. When the product flow reaches a maximum or desired flow rate, lock the regulator adjusting screw with a lock nut.

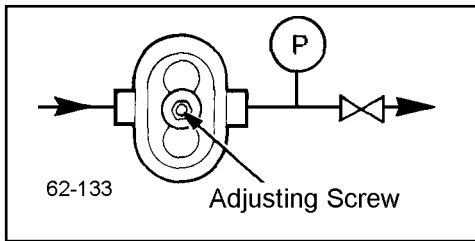

Figure 75 - Manual Adjustment

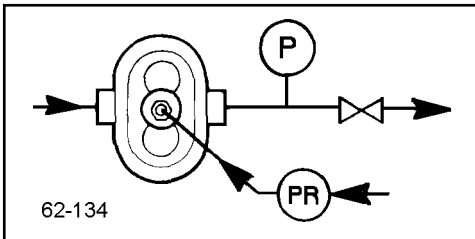

Figure 76 - Adjustment with a Pressure Gauge

Jacketed Cover

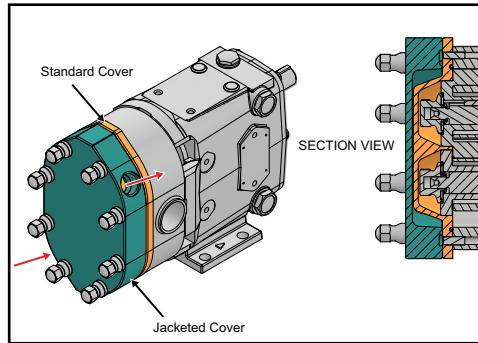

Figure 77 - Jacketed Cover

Table 13: Pipe Tap

Model Number	Pipe Tap	O-ring
006 - 018	3/4 NPT	V70252
030 - 040	3/4 NPT	V70261
045 - 130	1 NPT	V07272
180, 220	1 NPT	V70280
210, 320-370	1 NPT	GD0117V00

The jacketed cover is designed to allow circulation of a heating or cooling medium. The purpose is to help preheat or cool the pumping head and sustain operating temperature during short shutdown periods. It should not be used as a heat exchanger to control pumping temperature during operation. The temperature rating is dependent on the rotor selection. See Table 8, “Rotor Clearances,” on page 47.

NOTE: Pressure limit for cover media is 60 PSI.

NOTE: Jacketed covers require longer mounting studs in the gear case.

Low Pressure Flush

1. Set flow rate of approximately 1/4 GPM for most applications. For high temperature applications, increase flow. (See “If the pumped product contains abrasive solids or hardens on the seal faces, an alternate high pressure barrier flush arrangement may be used. A very small amount of flush liquid enters the pumped liquid, therefore the flush media must be compatible with the product.” on page 23.)
2. The flush media (water or lubricating fluid compatible with the product) must be connected and flowing whenever the pump is operated. Flushing media is restricted on the inlet side and has free flow to drain on the outlet side.
3. Typical flushing connections are 1/8" NPT female pipe taps.

See also “Seal Flush Connections” on page 23 and “If the pumped product contains abrasive solids or hardens on the seal faces, an alternate high pressure barrier flush arrangement may be used. A very small amount of flush liquid enters the pumped liquid, therefore the flush media must be compatible with the product.” on page 23.

Flushing Connection - Aseptic Series

All connections are 1/8" female pipe taps. The pump has double "barriers" or seals at every opening to the pump chamber. Live steam or a sterile fluid is circulated between these double seals at the ports, in the cover and at the shaft seals.

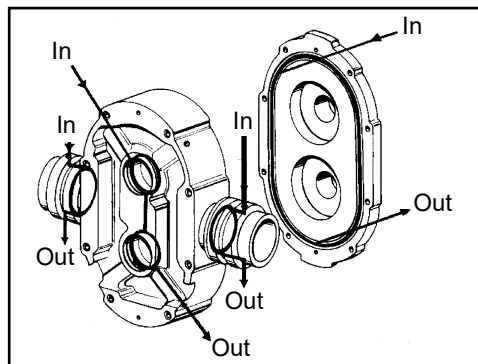

Figure 78 - Flushing Connection - Aseptic Series

Triple Lip Seal- Disassembly and Assembly

Remove Lip Seal

NOTE: 1. Before starting the maintenance of the Triple Lip Seal, make sure you have the spare parts, see page 105 and tools ready.

2. Removal of cover, rotor and pump body process, see page 34.

1. Remove all the retainer-tab bolts (72) and retainer-tabs (71) from the pump body, as shown in Figure 79. This is *applicable for model 006-130*.

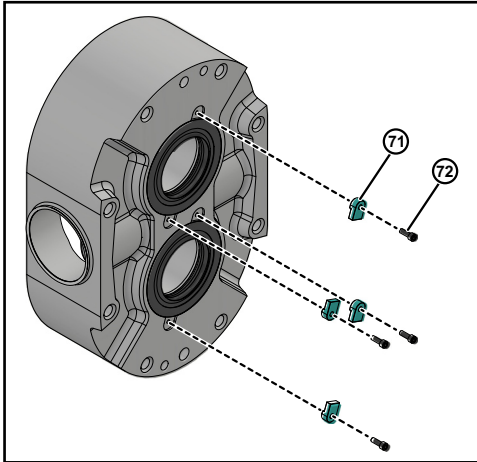

Figure 79 - Remove Screws and Retainer-tab

2. Remove all the retainer-tab bolts (72) and retainer-tabs (71) from the pump body, as shown in Figure 80. This is *applicable for model 180-370*.

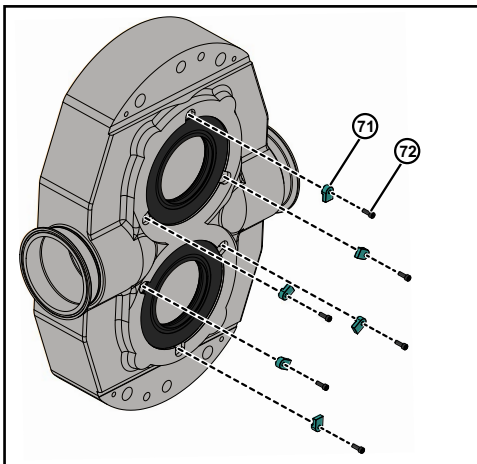

Figure 80 - Remove Screws and Retainer-tab

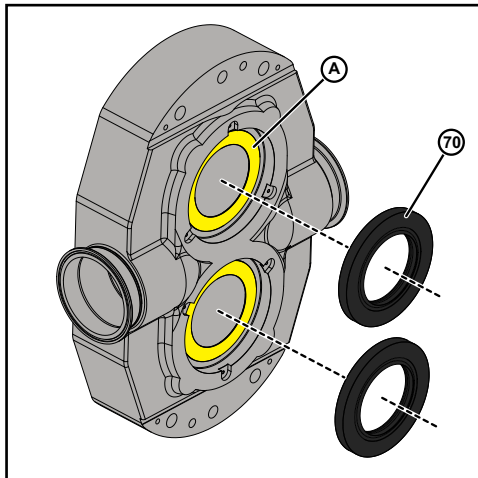

Figure 81 - Remove Lip seals

3. Remove and discard the lip seal (70) by using suitable tool like claw hammer/screw driver etc.
4. Remove the thin bead of silicone sealant (A) from the body, as shown in Figure 81.

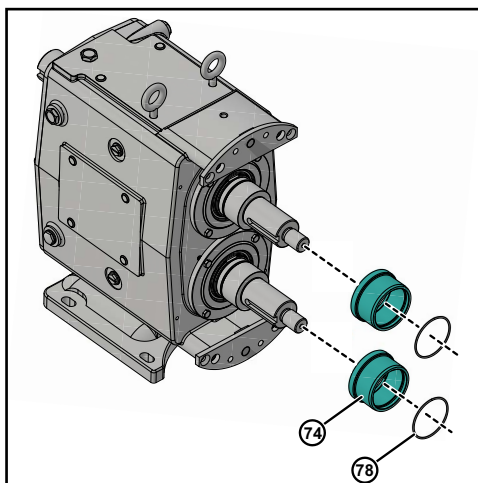

Figure 82 - Remove Sleeves and O-rings

5. Remove the two sleeves (74) along with two sleeve O-rings (78), as shown in Figure 82.

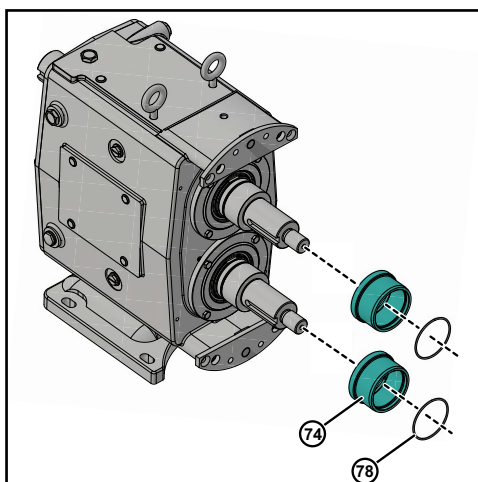

Figure 83 - Install Sleeves and O-rings

Install Lip Seal

1. Lubricate the two sleeve O-rings (78) with a lubrication compound compatible with the O-ring material and process fluid(s). Install the sleeve O-rings (78) into the groove of the sleeve (74),
2. Install the two sleeves (74) on the shaft, as shown in Figure 83.

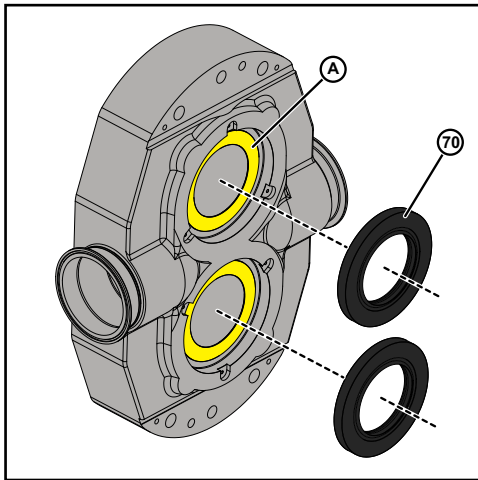

Figure 84 - Install Lip Seals

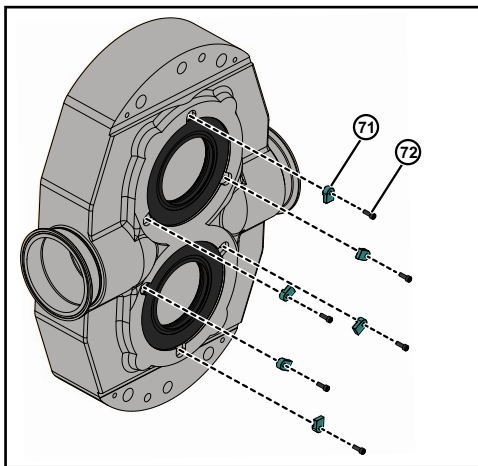

Figure 85 - Install Screws and Retainer-tab

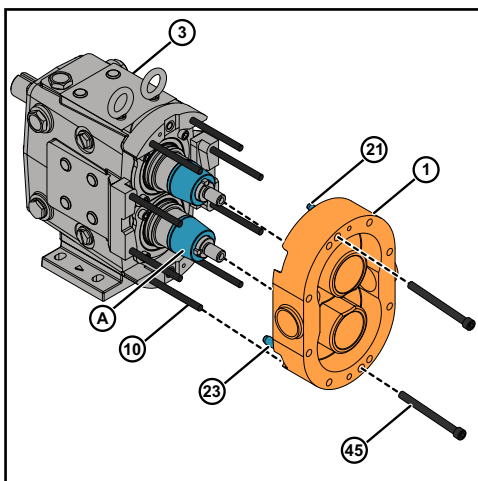

Figure 86 - Install pump body

3. Apply a thin bead of silicone sealant (A) to the body, as shown in Figure 84.
4. Install the lip seals (70) into the pump body, as shown in Figure 84. Use the press tool to light press firmly and evenly into place.
5. Lubricate the seal faces with a lubricant compatible with the process fluid(s).

6. Install all the retainer-tab (71) and retainer bolts (72) onto the pump body, as shown in Figure 85.

NOTE: For pump size 006-130, there are 2 Qty of Retainer-Tabs and 2 Qty of Bolts for per lip seal.

Install Pump body

1. Install the installation guide (A) on both shafts to avoid damaging the lip seals as the pump body is drawn over the shafts. Ensure the front face of installation guide is attached to the back face of sleeve, as shown in Figure 86. See the installation guide part numbers Table on page 118.
2. Match the large and small dowel pin (21 & 23) sizes on the pump body (1) with the dowel pin holes in the pump gear case (3).
3. Install the pump body (1) to the gear case assembly (3), aligning the pump body with the body studs (10) and gradually tighten the two cap screw(45).

CAUTION

To lift the body of a 130 or larger U2, use a lifting strap threaded through the ports on either side of the body.

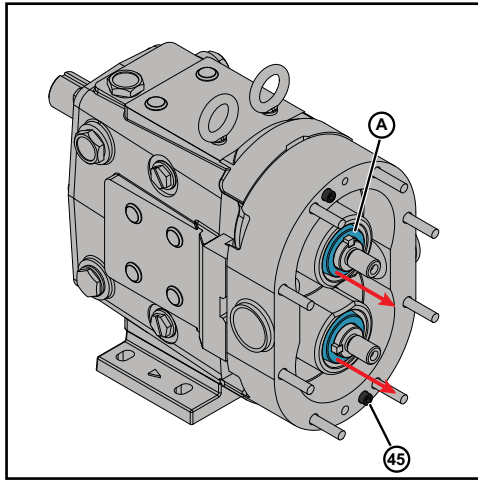

Figure 87 - Install Cap screw

4. Secure the pump body to the gear case using two cap screws (45).
5. Remove both the installation guide (A) from the pump body, as shown in Figure 87.

NOTE: Installation of cover and rotor process, see page 51.

NOTE: For the triple lip seal part list see page 105.



Reference Tables

Model	Rotor Nut	Body Retaining Cap Screw	Cover Nut
006, 014, 015, 018	15/16"	3/16"	5/8"
030, 034, 040	1-1/4"		
045, 060, 064, 130, 134	1-5/8"	1/4"	7/8"
180, 184, 220, 224	2-1/4"	5/16"	
210, 213, 214, 320, 323, 324, 370	2-3/8"		1"

Model	Gear Nut	Rotor Nut	Cover Nut	Gear Nut Driver Tool
006, 015, 018	120 ft-lb 163 N·m	50 ft-lb 68 N·m	7 ft-lb 10 N·m	109281+
030, 040		120 ft-lb 163 N·m	11 ft-lb 15 N·m	109282+
045, 060	140 ft-lb 190 N·m	250 ft-lb 339 N·m	56 ft-lb 76 N·m	109283+
130			25 ft-lb 34 N·m	
180, 220	230 ft-lb 312 N·m	325 ft-lb 441 N·m	110 ft-lb 149 N·m	110304+
210, 213, 320, 323, 370	320 ft-lb 434 N·m	375 ft-lb 508 N·m	158 ft-lb 214 N·m	114702+

Model	Shaft		Front Bearing		Rear Bearing	
	IN	OUT	ON	OFF	ON	OFF
006, 014, 015, 018	.25	.50	.50	1.00	.50	1.00
030, 034, 040	.25	1.00	.50	1.00	.50	1.00
045, 060, 064, 130, 134	.50	1.00	2.00	5.00	3.00	5.00
180, 184, 220, 224	.50	1.00	5.00	15.00	5.00	15.00
210, 213, 214, 320, 323, 324, 370	.50	1.00	5.00	2.00	5.00	2.00

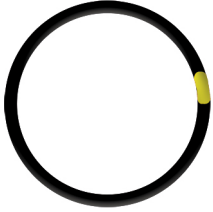
Table 17: Standard O-Ring Selections, Descriptions and Color Codes for Universal Pumps

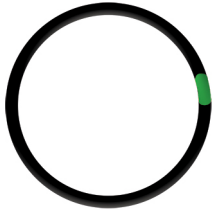
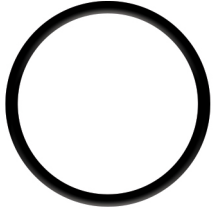
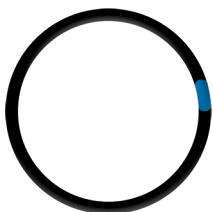
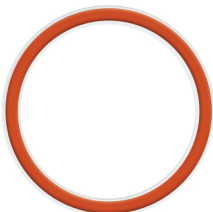
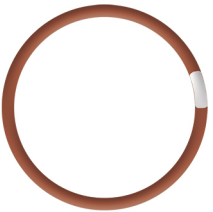
<p>Nitrile (Buna-N) (NBR) Compound Color: Black Color Code: Yellow FDA Compliant to 21CFR177.2600 3A Sanitary</p>		<p>Silicone (Si) Compound Color: Orange Color Code: Black FDA Compliant to 21CFR177.2600 3A Sanitary</p>	
<p>Ethylene Propylene Diene Rubber (EPDM) Compound Color: Black or Purple Color Code: Green FDA Compliant to 21CFR177.2600</p>		<p>Perfluoroelastomer (FFKM) Compound Color: Black Color Code: None Individually packaged with size and material noted.</p>	
<p>Ethylene Propylene Diene Rubber (Sulfur Free) (EPDM) Compound Color: Black or Purple Color Code: Blue FDA Compliant to 21CFR177.2600</p>		<p>PTFE Encapsulated Compound Color: Translucent coating over Orange or Black Silicone or FKM core Color Code: None FDA Compliant to 21CFR177.2600</p>	
<p>Fluorocarbon Rubber (FKM) Compound Color: Rust, Brown or Black Color Code: White FDA Compliant to 21CFR177.2600 3A Sanitary</p>			

Troubleshooting

PROBLEM	POSSIBLE CAUSE	SUGGESTED ACTION
No flow, pump rotors are not turning	Drive motor not running.	Check resets, fuses, circuit breakers.
	Keys sheared or missing.	Replace.
	Drive belts, power transmission components slipping or broken.	Replace or adjust.
	Pump shaft, keys, or gears sheared.	Inspect: and replace parts as necessary.
No flow, pump rotors are turning	Rotors turn in the wrong direction.	Check motor hookup to reverse motor rotation.
	Relief valve not properly adjusted, or held open by foreign material.	Adjust or clear valve.
	Suction port is blocked, not allowing flow to the pump.	Check all inlet valves, strainers, tank outlet ports.
No flow, pump not priming	Valve closed in inlet line.	Open valve.
	Inlet line clogged or restricted.	Clear line, clean filters, etc.
	Air leaks due to bad gaskets or pipe connections.	Replace gaskets; check lines for leakage (can be done by air pressure or by filling with liquid and pressurizing with air).
	Pump speed too slow.	Increase pump speed.
	Pump speed too fast for high-viscosity liquid.	Decrease pump speed.
	Liquid drains or siphons from system during off periods.	Use foot valve or check valves. Filling inlet lines with material before startup may solve startup priming problems due to no material in system.
	"Air" lock caused by fluids which "gas off", or vaporize, or allow gas to come out of solution during off periods.	Install and use a manual or automatic air bleed from pump or lines near pump.
	Extra clearance rotors, worn pump.	Increase pump speed, use foot valve to improve priming. Replace worn rotors.
	Net inlet pressure available too low.	Check Net Inlet Pressure Available & Net Inlet Pressure Required. Change inlet system as needed.
	On "Vacuum" inlet system: On initial start-up, atmospheric "blow back" prevents pump from developing enough differential pressure to start flow.	Install check valve in discharge line.

PROBLEM	POSSIBLE CAUSE	SUGGESTED ACTION
Insufficient flow	Speed too low or too high to obtain desired flow.	Check flow-speed curve (available from SPX FLOW website) and adjust as necessary.
	Air leak due to bad seals, pipe connections, or other equipment.	Replace seals, check inlet fittings.
Insufficient flow—flow being bypassed somewhere	Flow diverted in branch line, open valve, etc.	Check system and controls
	Relief valve not adjusted or jammed.	Clear or adjust valve.
Insufficient flow—high slip	Hot (HC) or extra clearance rotors on "cold" fluid and/or low viscosity fluid.	Replace with standard clearance rotors.
	Worn pump.	Increase pump speed (within limits). Replace rotors, have pump remanufactured.
	High pressure.	Reduce pressure by adjusting system settings or hardware.
Fluid vaporization ("starved" pump inlet)	Strainers, foot valves, inlet fittings or lines clogged.	Clear lines. If problem continues, inlet system may require changing.
	Inlet line size too small, inlet line too long. Too many fittings or valves. Foot valve, strainers too small.	Increase inlet line size. Reduce length, minimize direction and size changes, reduce number of fittings.
	NIPA - Net Inlet Pressure Available at Pump is too low.	Raise liquid level in source tank to increase Net Inlet Pressure (NIPA). Increase Net Inlet Pressure Available at Pump by raising or pressurizing source tank.
		Select larger pump size with lower Net Inlet Pressure Required.
	Fluid viscosity greater than expected.	Reduce pump speed and accept lower flow, or change system to reduce line losses. Change temperature of product to reduce viscosity.
	Fluid temperature higher than expected (vapor pressure higher).	Reduce temperature, reduce speed and accept lower flow or change system to increase Net Inlet Pressure Available.

PROBLEM	POSSIBLE CAUSE	SUGGESTED ACTION
Noisy operation	Cavitation	
	High fluid viscosity. High vapor pressure fluid. High temperature.	Slow down pump, reduce temperature, change system setup.
	Net Inlet Pressure Available less than Net Inlet Pressure Required.	Increase NIPA - Net Inlet Pressure Available or reduce NIPR - Net Inlet Pressure Required. Contact SPX FLOW if necessary.
	Air or gas in fluid	
	Leaks in the pump or piping.	Correct leaks.
	Dissolved gas or naturally aerated products.	Minimize discharge pressure (also see "Cavitation," above).
Noisy operation caused by mechanical problems	Rotor to body contact	
	Improper assembly of pump.	Check clearances and adjust shimming.
	Distortion of pump due to improper piping installation.	Change piping installation to eliminate piping stress and distortion on body.
	Pressures required higher than the pump is rated for.	Reduce discharge pressure required.
	Worn bearings.	Rebuild with new bearings and lubricate regularly.
	Rotor to Rotor Contact	
	Loose or incorrectly-timed gears.	This has caused severe damage to components - rebuild with new parts.
	Sheared keys.	This has caused severe damage to components - rebuild with new parts.
	Worn gear splines.	This has caused severe damage to components - rebuild with new parts.
	Drive noise caused by gear trains, chains, couplings, bearings.	Repair or replace drive parts. Check bearings for damage and replace as necessary.
Pump requires excessive power (overheats, stalls, high current draw, breakers trip)	Higher than expected viscosity losses.	If within pump rating, increase drive size.
	Higher than expected pressures.	Reduce pump speed. Increase line sizes.
	Fluid is colder with a higher viscosity than expected.	Heat fluid, insulate lines or heat trace lines. Increase line sizes.

PROBLEM	POSSIBLE CAUSE	SUGGESTED ACTION
Pump requires excessive power (overheats, stalls, high current draw, breakers trip)	Fluid sets in line and pump during shutdown.	<p>Insulate lines or heat trace lines.</p> <p>Install a “soft start” drive.</p> <p>Install a recirculating bypass system.</p> <p>Flush system with a nonsetting fluid.</p>
	Fluid builds up on pump surfaces.	Replace the pump with more running clearances.
Short pump service life	Pumping abrasives	Larger pumps at slower speeds.
	Speeds and pressures higher than rated.	<p>Reduce speeds and pressures by making changes in the system.</p> <p>Replace pump with a larger model with higher pressure ratings.</p>
	Worn bearings and gears due to lack of lubrication.	<p>Check and replace bearing and gears as necessary. Adjust lubrication schedule to decrease time between lubrication.</p> <p>Modify external wash down method to reduce water entering into gear case.</p>
	Misalignment of drive and piping. (Excessive overhung load or misaligned couplings.)	Check alignment of piping and drive. Adjust as necessary.

Parts List

006, 014, 015, 018-U2 Pump Parts

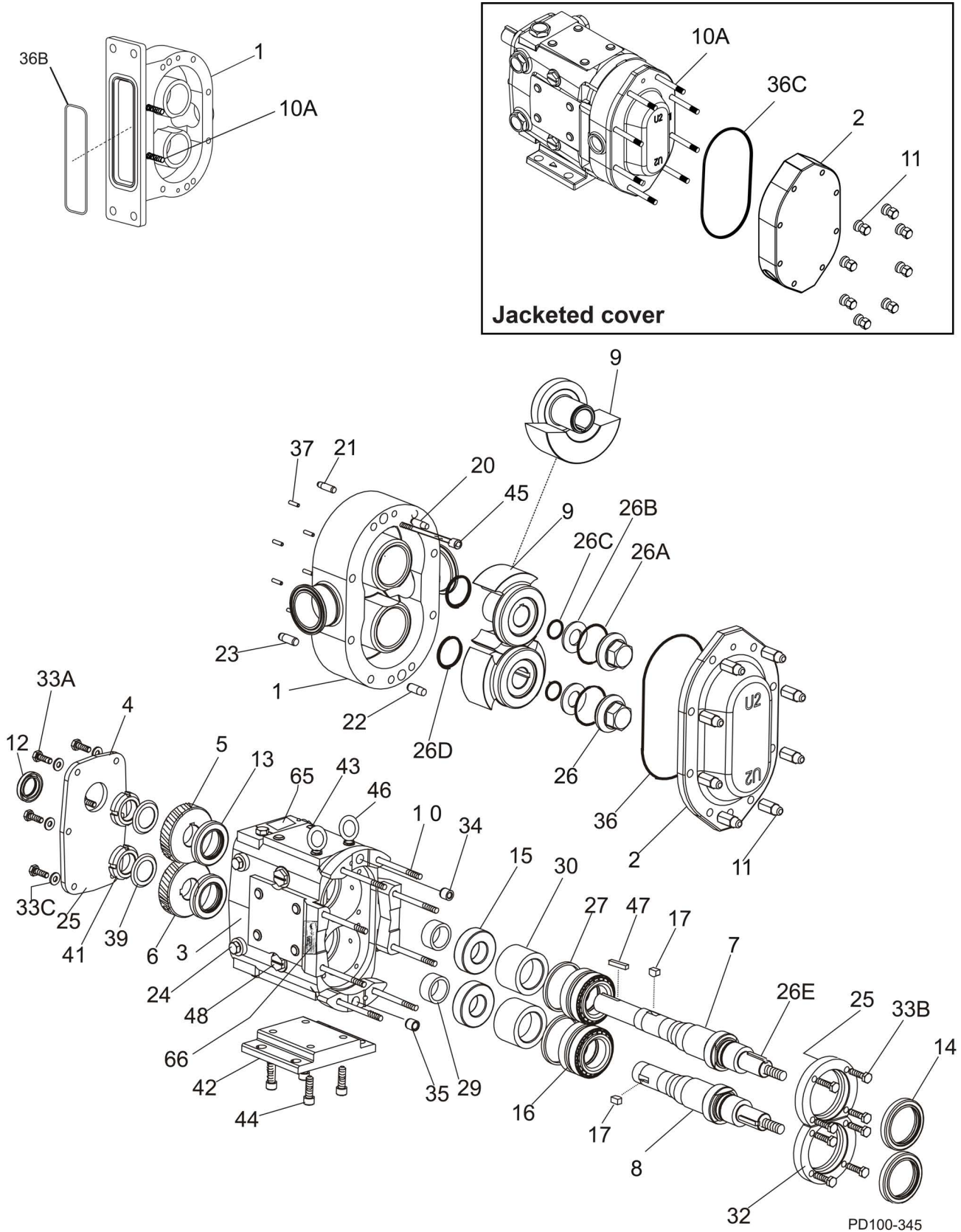

006, 014, 015, 018-U2 Pump Parts

ITEM NO.	DESCRIPTION	QTY. PER PUMP	PART NO.	NOTES
1	006-U2 Pump Body	1	See Note 1	1
	006-U2 Pump Body with Flush	1	See Note 1	1
	014-U2 Rectangular Flange Inlet Body	1	See Note 1	1
	014-U2 Rect. Flange Inlet Body with Flush	1	See Note 1	1
	015-U2 Pump Body	1	See Note 1	1
	015-U2 Pump Body with Flush	1	See Note 1	1
	018-U2 Pump Body	1	See Note 1	1
	018-U2 Pump Body with Flush	1	See Note 1	1
3	Gear Case Assembly, CI, Model 006/015	1	POA	3, 4
	Gear Case Assembly, SS; Model 006/015 (Optional)	1	POA	3, 4
	Gear Case Assembly, CI, Model 018	1	POA	3, 4
	Gear Case Assembly, SS; Model 018 (Optional)	1	POA	3, 4
7	006-014-015-U2 Drive Shaft	1	108405+	41, 47
	018-U2 Drive Shaft	1	108407+	41, 47
8	006-014-015-U2 Short Shaft	1	108406+	47
	018-U2 Short Shaft	1	108408+	47
9	006-U2 Rotor, Twin Wing, Alloy 88	2	101870+	2
	006-U2 Rotor, Twin Wing, 316SS	2	102199+	2
	014-015-U2 Rotor, Twin Wing, Alloy 88	2	101882+	2
	014-015-U2 Rotor, Twin Wing, 316SS	2	102205+	2
	015-U2 Rotor, Single Wing, Alloy 88	2	117060+	2, 13
	018-U2 Rotor, Twin Wing, Alloy 88	2	101894+	2
	018-U2 Rotor, Twin Wing, 316SS	2	102211+	2
	018-U2 Rotor, Single Wing, Alloy 88	2	117072+	2, 13
10	006-015-U2 Stud	8	AD0011000	
10	014-U2 Stud	6	AD0011000	
	014-U2 Stud	2	35547+	
10	018-U2 Stud	8	101721+	
10A	006-015-U2 Stud, Jacketed Cover	8	AD0011J00	
10A	006-015-U2 Stud, Jacketed Cover	8	307977+	45
10A	014-U2 Stud, Jacketed Cover	6	AD0011J00	
	014-U2 Stud, Jacketed Cover	2	35548+	
10A	014-U2 Stud, Jacketed Cover	8	307977+	45
10A	018-U2 Stud, Jacketed Cover	8	107754+	
10A	018-U2 Stud, Jacketed Cover	8	307978+	45

Notes:

1. Contact customer service with serial number of pump for part number.
2. Standard clearances and finishes for rotor part numbers shown. Contact customer service for optional clearances and finishes.
3. Gear Case Assemblies listed are upper drive, side mount left hand, and include shafts and timing gears. CI assemblies are painted WCB blue. Contact customer service for other options.
4. Please contact the SPX Flow Customer Service for Gear Case options.
13. Single wing rotors cannot be used with rectangular flange inlet pumps.
41. Tru-Fit drive shaft is longer than the standard drive shaft listed here. See page 116.
45. Studs to be installed with a jacketed cover (0300549+).
46. For Tru-Fit parts, see page 116.
47. For shaft & bearing assembly part numbers, see page 112.

006, 014, 015, 018-U2 Common Parts

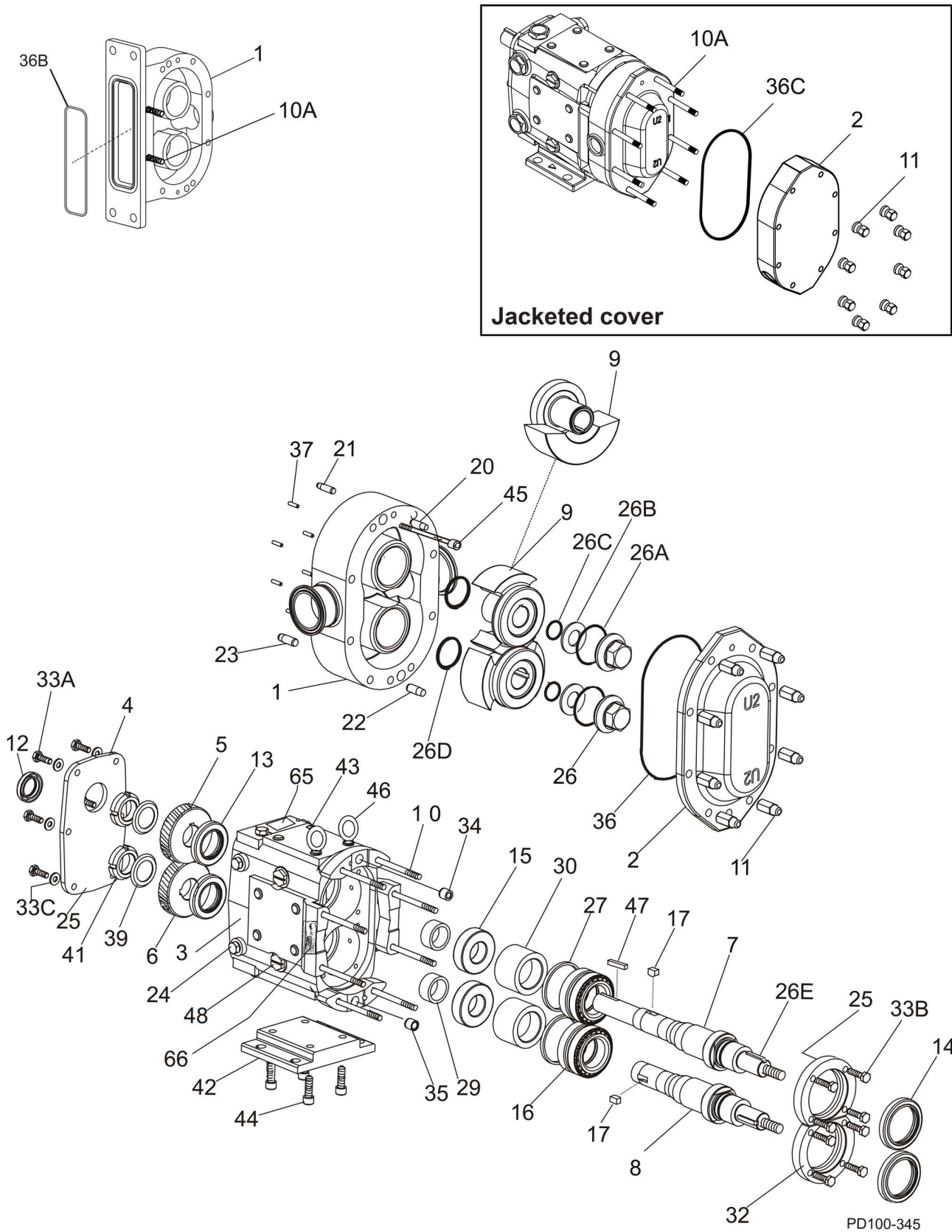

006, 014, 015, 018-U2 Common Parts

ITEM NO.	DESCRIPTION	QTY. PER PUMP	PART NO.	NOTES
2	Pump Cover	1	101842+	
	Pump Cover	1	0300602-01+	48
2A	Jacketed Cover	1	107664+	
	Jacketed Cover	1	0300549+	49
2	Pump Cover Vented - Complete Assembly	1	POA	1
4	Gear Case Cover, Steel	1	020106000+	
	Gear Case Cover, SS; Optional	1	102280+	
5	Gear, Drive Shaft, Spur	1	107997+	
6	Gear, Short Shaft, Spur	1	107997+	
11	Hex Nut	8	108369+	
	Wing Nut; Optional	8	105850+	
12	Oil Seal, Gear Case Cover	1	000030016+	
13	Oil Seal, Gear Case Rear	2	000030017+	
14	Grease Seal, Bearing Retainer, standard gearcase	2	121679+	3, 4
	Grease Seal, Bearing Retainer, SS Gearcase or Bearing Isolator	2	101716+	4
15	Bearing, Rear	2	015035000+	
16	Bearing, Front	2	101714+	
17	Key, Gear	2	015037000+	
20	Dowel Pin, Cover Side, .245" x .85"	1	137001+	43
21	Dowel Pin, Gear Case Side, .245" x 1.0"	1	124581+	44
22	Dowel Pin, Cover Side, .308" x .85"	1	137002+	43
23	Dowel Pin, Gear Case Side, .308" x 1.0"	1	124582+	44
24	Oil Plug, M20 x 1.5"	5	115798+	40
	Oil Level Indicator, M20 x 1.5"	1	115799+	
	Oil Level Indicator, SS, M20 x 1.5"	1	137435+	
	Oil Level Indicator, ATEX, M20 x 1.5	1	131417+	
25	Silicone Sealant	1	000142301+	
26	Nut, Rotor	2	101804+	
26A*	O-Ring, Rotor Nut, Buna N	2	N70126	
	O-Ring, Rotor Nut, EPDM	2	E70126	
	O-Ring, Rotor Nut, FKM	2	V70126	
26B*	Washer, Belleville	2	101691+	
26C*	O-Ring, Retainer, Buna N	2	N70112	
	O-Ring, Retainer, EPDM	2	E70112	
	O-Ring, Retainer, FKM	2	V70112	
26D*	O-Ring, Rotor Hub, Buna N	2	N70121	
	O-Ring, Rotor Hub, EPDM	2	E70121	
	O-Ring, Rotor Hub, FKM	2	V70121	

Notes:*** Recommended Spare Parts**

- Please configure in eSales or contact customer service.
- Pumps manufactured prior to June 2004 use 000030018+ for the grease seal.
- Pumps with bearing isolators use 101716+ as the grease seal and 101810+ as the bearing retainer. For bearing isolator kit, and pumps older than 7/12/04, see page 113.
- Applies to pumps shipped after October 2003. Pumps shipped prior to October 2003 used qty 6 of plug w/washer, part number 000046002+.
- Exposed length of dowel pin: .444" (11.3 mm)
- Exposed length of dowel pin: .563" (14.3 mm)
- For shaft & bearing assembly part numbers, see page 112.
- Pump cover are available from June 22, 2023
- Jacketed cover are available from March 30, 2023.

006, 014, 015, 018-U2 Common Parts, cont'd

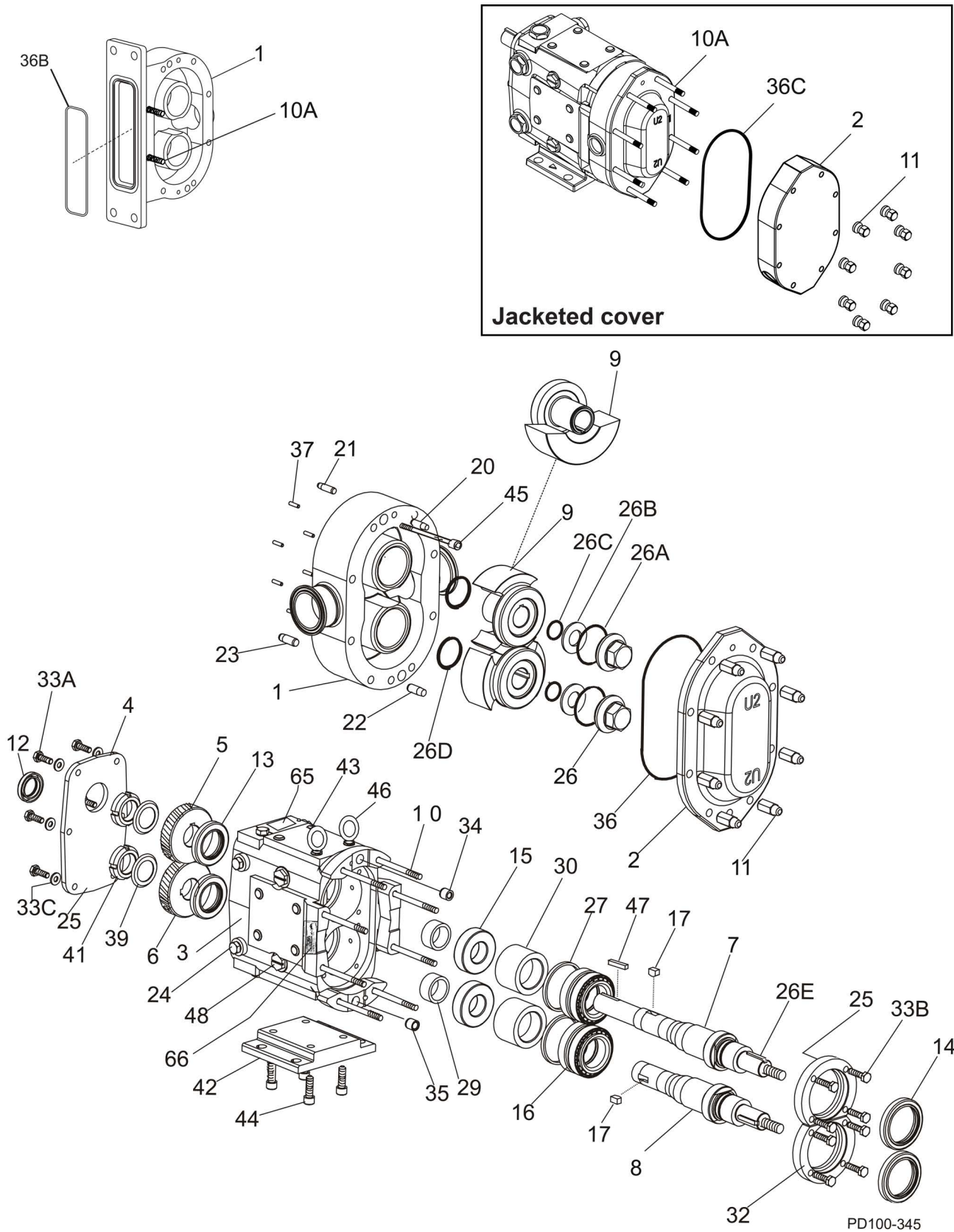

006, 014, 015, 018-U2 Common Parts, cont'd

ITEM NO.	DESCRIPTION	QTY. PER PUMP	PART NO.	NOTES
26E	006-014-015-U2 Key, Rotor	2	101817+	
	018-U2 Key, Rotor	2	101819+	
27	Shim Kit	2	117889+	
29	Spacer, Gear to Rear Bearing	2	015055000+	
30	Bearing Spacer	2	101814+	
32	Bearing Retainer, Front SS, for standard gearcase	2	120332+	4
	Bearing Retainer, Front SS, for SS Gearcase or Bearing Isolator	2	101810+	4
33A, 33B	1/4-20 x .75" HHCS, SS	14	30-58	
33C	1/4" Flat Washer	6	43-27	
34	Dowel Bushing, Upper	1	AD0116000	
35	Dowel Bushing, Lower	1	AD0116 100	
36*	O-Ring, Pump Cover, Buna N	1	N70249	
	O-Ring, Pump Cover, EPDM	1	E70249	
	O-Ring, Pump Cover, FKM	1	V70249	
36B*	014-U2 O-Ring, Rectangular Flange, Buna N	1	N70241	
	014-U2 O-Ring, Rectangular Flange, EPDM	1	E70241	
	014-U2 O-Ring, Rectangular Flange, FKM	1	V70241	
36C*	O-Ring, Pump Jacketed Cover, Buna N	1	N70252	
	O-Ring, Pump Jacketed Cover, EPDM	1	E70252	
	O-Ring, Pump Jacketed Cover, FKM	1	V70252	
	O-Ring, Pump Jacketed Cover, Silicone	1	S75251	
37	Stop Pin, Seal	6	101718+	
39	Lockwasher, Gear	2	STD136005	
41	Locknut, Gear	2	STD236005	
42	Gear Case Shim, CI	1	020110000+	
	Gear Case Shim, SS; Optional	1	102284+	
	Pump Pedestal, 6.75", Optional	1	014110675+	
43	Plastic Cap Plug	8	000121003+	
44	5/16-18 x 1" SHCS, SS	4	30-525	
	006-014-015-U2 Body Retaining Screw, 1/4-20 x 1-1/4"	2	30-523	
45	018-U2 Body Retaining Screw, 1/4-20 x 2"	2	30-211	
	Eye Bolt, 5/16-18 x .50" ZP 2	2	30-722	
47	Key, Coupling - 3/16 x 3/16 x 1-1/8"	1	000037001+	
	Key, Coupling - Tru-Fit	1	119714+	
48	Cleanout Plug	2	35824+	15
61	Name Plate, Sanitary	1	135623+	
62	#2 x .187" RHDS	4	30-355	
65	Caution Plate	2	121694+	
66	Warning Label	2	33-63	
67	006-015-018-U1 Grease Fitting, 1/8"	4	BD0092000	2
	014-U1 Grease Fitting, 1/8"	4	BD0092100	3
68	Plastic Cap, Grease Fitting	4	BD0093000	

Notes:

* Recommended Spare Parts

2. This grease fitting is the straight style. Part number BD0092100 is the angled style.
3. This grease fitting is the angled style. Part number BD0092000 is the straight style.
4. 101810+ bearing retainer is used with 101716+ grease seal. For bearing isolator kit, and for pumps older than 7/12/04, see page 113.
15. For an older gear case without a threaded plug hole, use plug p/n 000121003+.
16. For seals, see page 102.
17. For vented covers, see page 114.

030, 034, 040-U2 Pump Parts

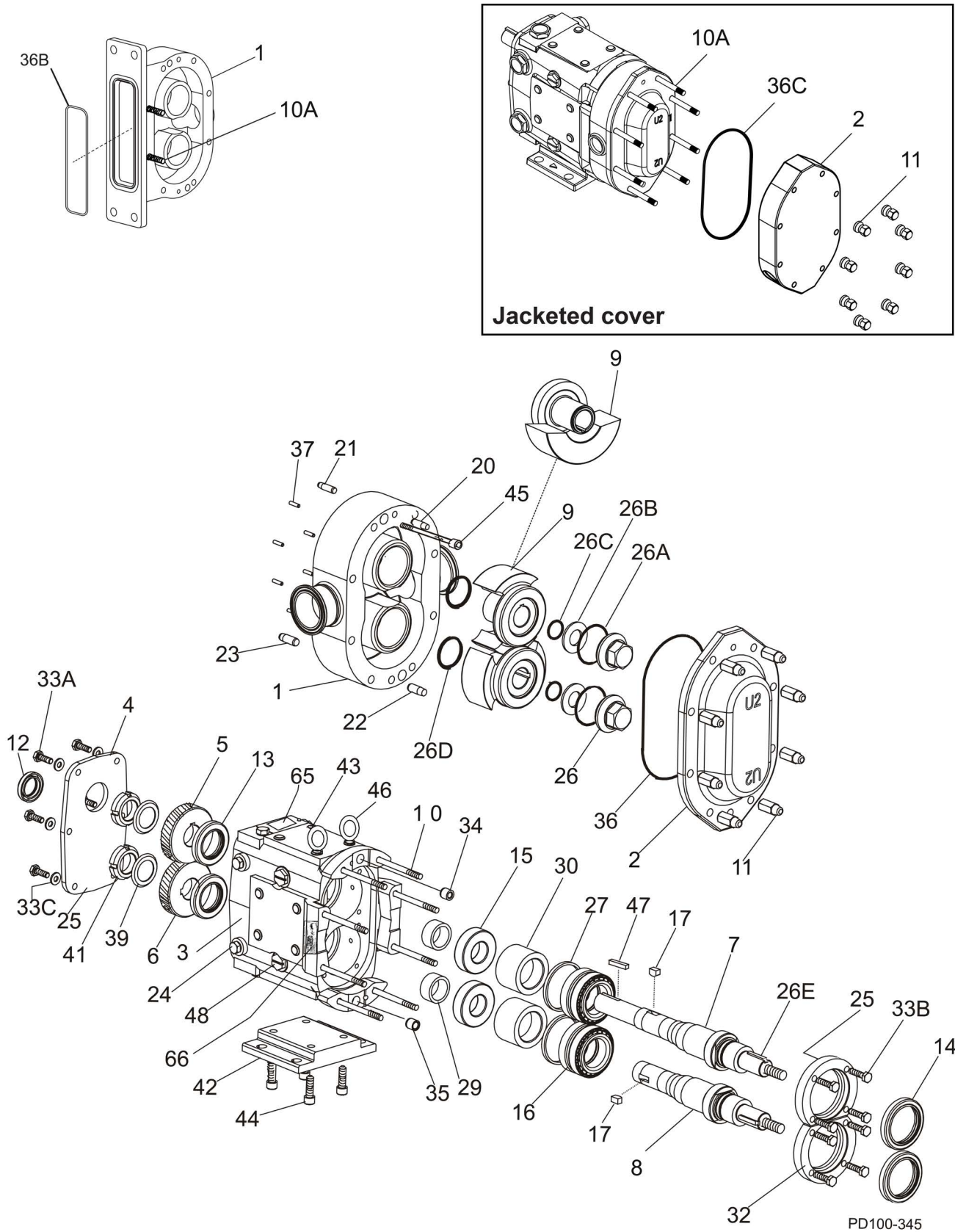

030, 034, 040-U2 Pump Parts

ITEM NO.	DESCRIPTION	QTY. PER PUMP	PART NO.	NOTES
1	030-U2 Pump Body	1	See Note 1	1
	030-U2 Pump Body with Flush	1	See Note 1	1
	034-U2 Rectangular Flange Inlet Body	1	See Note 1	1
	034-U2 Rectangular Flange Inlet Body with Flush	1	See Note 1	1
	040-U2 Pump Body	1	See Note 1	1
	040-U2 Pump Body with Flush	1	See Note 1	1
3	030-034-U2 Gear Case Assembly, CI	1	POA	3, 4
	030-034-U2 Gear Case Assembly, SS; Optional	1	POA	3, 4
	040-U2 Gear Case Assembly, CI	1	POA	3, 4
	040-U2 Gear Case Assembly, SS; Optional	1	POA	3, 4
7	030-034 U2 Drive Shaft	1	108409+	41
	040 U2 Drive Shaft	1	118722+	41
8	030-034 U2 Short Shaft	1	108410+	
	040-U2 Short Shaft	1	118723+	
9	030-034-U2 Rotor, Twin Wing, Alloy 88	2	102151+	2
	030-034-U2 Rotor, Twin Wing, 316SS	2	102217+	2
	030-U2 Rotor, Single Wing, Alloy 88	2	117084+	2, 12, 13
	030-U2 Rotor, Single Wing, 316SS	2	117088+	2, 12A, 13
	040-U2 Rotor, Twin Wing, Alloy 88	2	118766+	2
	040-U2 Rotor, Twin Wing, 316SS	2	118779+	2
	040-U2 Rotor, Single Wing, Alloy 88	1	124255+	2, 13
	040-U2 Rotor, Single Wing, 316SS	1	124268+	2, 13
10	030-U2 Stud	8	108842+	
10	034-U2 Stud	6	108842+	
	034-U2 Stud	2	35555+	
10	040-U2 Stud	8	118897+	
10A	030-U2 Stud, Jacketed Cover	8	108845+	
10A	034-U2 Stud, Jacketed Cover	6	108845+	
	034-U2 Stud, Jacketed Cover	2	35549+	
10A	040-U2 Stud, Jacketed Cover	8	118898+	

Notes:

1. Contact customer service with serial number of pump for part number.
2. Standard clearances and finishes for rotor part numbers shown. Contact customer service for optional clearances and finishes.
3. Gear case assemblies listed are upper drive, side mount left hand, and include shafts and timing gears. CI assemblies are painted WCB blue. Contact customer service for other options.
4. Please contact the SPX Flow Customer Service for Gear Case options.
12. Replaces P/N 104707 (straight) and P/N 104836 (90 degree) rotors.
- 12A. Replaces P/N 104719 (straight) and P/N 104848 (90 degree) rotors.
13. Single wing rotors cannot be used with rectangular flange inlet pumps.
41. Tru-Fit drive shaft is longer than the standard drive shaft listed here. See page 116.
47. For shaft & bearing assembly part numbers, see page 112.

030, 034, 040-U2 Common Parts

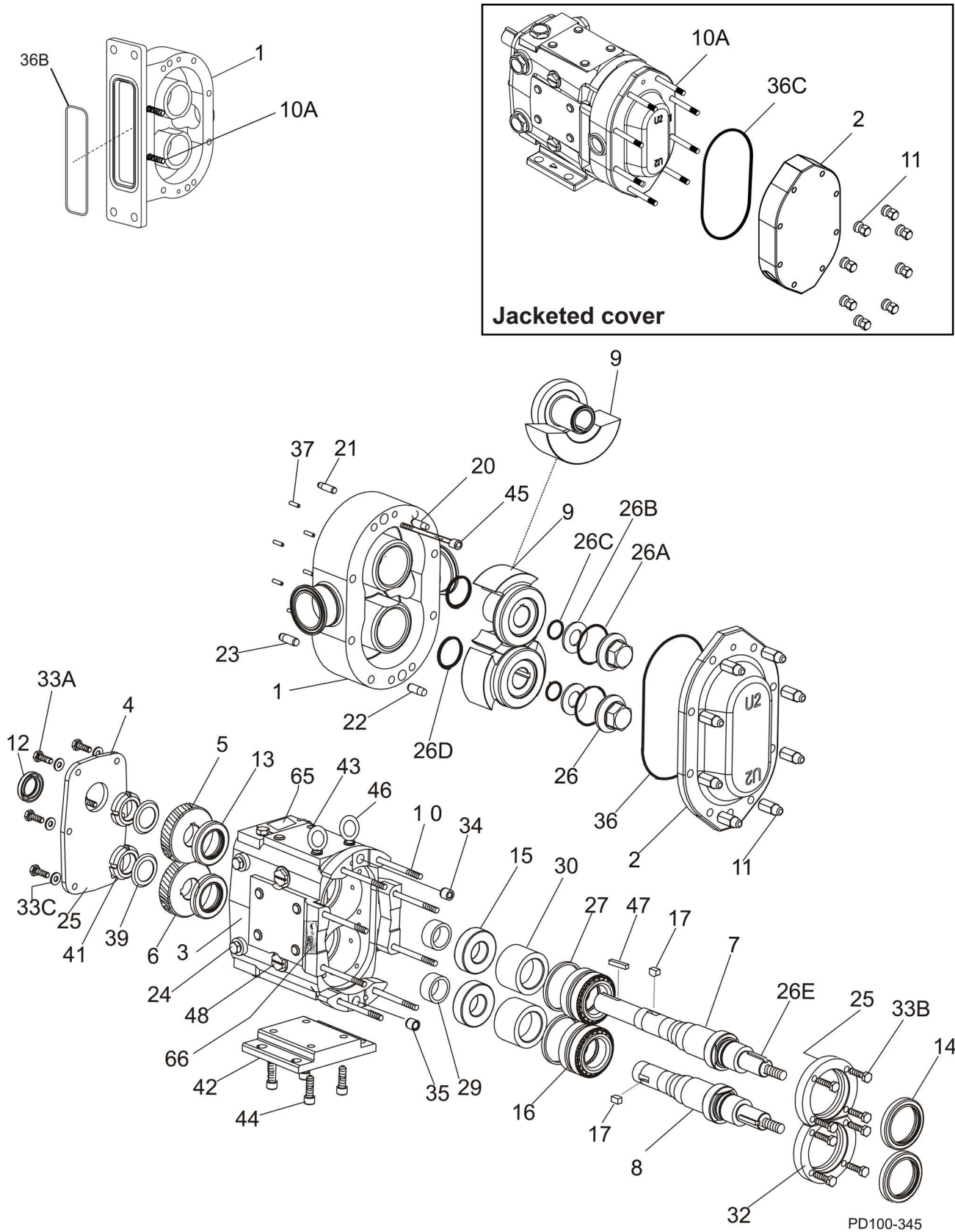

030, 034, 040-U2 Common Parts

ITEM NO.	DESCRIPTION	QTY. PER PUMP	PART NO.	NOTES
2	Pump Cover	1	101845+	
	Pump Cover	1	0301104-01+	48
2A	Jacketed Cover	1	107666+	
	Jacketed Cover	1	0300544+	49
2	Pump Cover Vented - Complete Assembly	1	POA	1
4	Gear Case Cover, Steel	1	040106000+	
	Gear Case Cover, SS; Optional	1	102281+	
5	Gear, Drive Shaft, Spur	1	107999+	
6	Gear, Short Shaft, Spur	1	107999+	
11	Hex Nut	8	108370+	
	Wing Nut; Optional	8	105851+	
12	Oil Seal, Gear Case Cover	1	000030013+	
13	Oil Seal, Gear Case Rear	2	000030014+	
14	Grease Seal, Bearing Retainer	2	121680+	2
15	Bearing, Rear	2	030035000+	
16	Bearing, Front	2	101715+	
17	Key, Gear	2	BD0037000	
20	Dowel Pin, Cover Side, .245" x .85"	1	137001+	43
21	Dowel Pin, Gear Case Side, .308" x 1.0"	1	124582+	44
22	Dowel Pin, Cover Side, .308" x .85"	1	137002+	43
23	Dowel Pin, Gear Case Side, .370" x 1.0"	1	124583+	44
24	Oil Plug, M20 x 1.5"	5	115798+	40
	Oil Level Indicator, M20 x 1.5"	1	115799+	40
	Oil Level Indicator, SS, M20 x 1.5"	1	137435+	
	Oil Level Indicator, ATEX, M20 x 1.5	1	131417+	
25	Silicone Sealant	1	000142301+	
26	Nut, Rotor	2	101805+	
26A*	O-Ring, Rotor Nut, Buna N	2	N70130	
	O-Ring, Rotor Nut, EPDM	2	E70130	
	O-Ring, Rotor Nut, FKM	2	V70130	
26B*	Washer, Belleville	2	101692+	
26C*	O-Ring, Retainer, Buna N	2	N70115	
	O-Ring, Retainer, EPDM	2	E70115	
	O-Ring, Retainer, FKM	2	V70115	
26D*	O-Ring, Rotor Hub, Buna N	2	N70127	
	O-Ring, Rotor Hub, EPDM	2	E70127	
	O-Ring, Rotor Hub, FKM	2	V70127	

Notes:

* Recommended Spare Parts

- Please configure in eSales or contact customer service.
- Pumps manufactured prior to June 2001 use 000030015+ for the grease seal. See page 113.
- Applies to pumps shipped after October 2003. Pumps shipped prior to October 2003 used qty 6 of plug with washer, part number 000046003+.
- Exposed length of dowel pin: .444" (11.3 mm)
- Exposed length of dowel pin: .563" (14.3 mm)
- For shaft & bearing assembly part numbers, see page 112.
- Pump cover are available from May 30, 2023
- Jacketed cover are available from November 23, 2022.

030, 034, 040-U2 Common Parts, cont'd

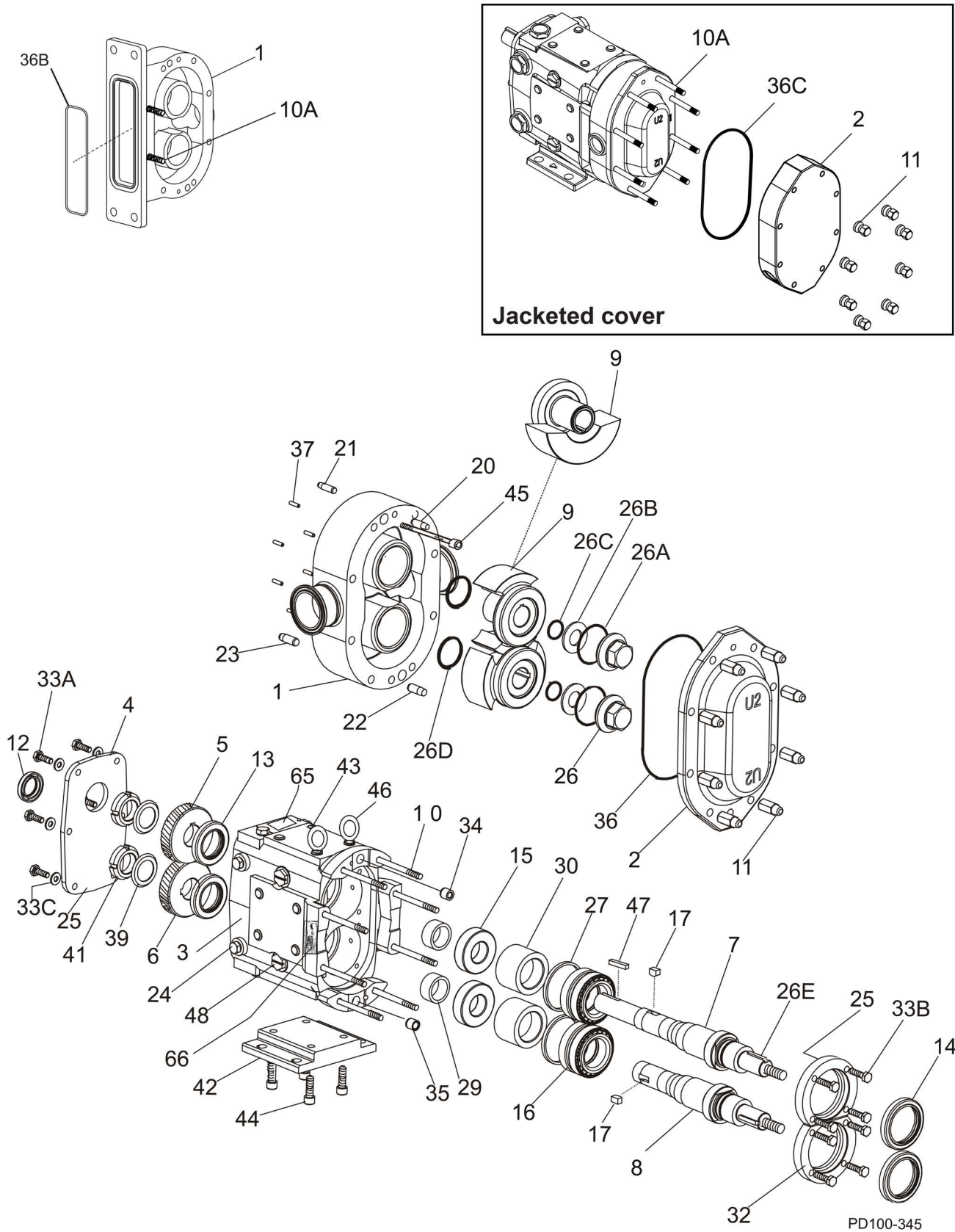

030, 034, 040-U2 Common Parts, cont'd

ITEM NO.	DESCRIPTION	QTY. PER PUMP	PART NO.	NOTES
26E*	Key, Rotor	2	101821+	
27	Shim Kit	2	117890+	
29	Spacer, Gear to Rear Bearing	2	030055000+	
30	Bearing Spacer	2	101815+	
32	Bearing Retainer, Front SS, for std. lip seal	2	120333+	3
33A	5/16-18 x 3/4" HHCS, SS	6	30-623	
33B	5/16-18 x 3/4" BSHCS, STD	8	30-296	
	5/16-18 x 3/4" SHCS, SS	8	30-29	
33C	5/16" Flat Washer	6	43-246	
34	Dowel Bushing, Upper	1	BD0116000	
35	Dowel Bushing, Lower	1	BD0116100	
36*	O-Ring, Pump Cover, Buna N	1	N70259	
	O-Ring, Pump Cover, EPDM	1	E70259	
	O-Ring, Pump Cover, FKM	1	V70259	
36B*	034-U2 O-Ring, Rectangular Flange, Buna N	1	N70357	
	034-U2 O-Ring, Rectangular Flange, EPDM	1	E70357	
	034-U2 O-Ring, Rectangular Flange, FKM	1	V70357	
36C*	O-Ring, Pump Jacketed Cover, Buna N	1	N70261	
	O-Ring, Pump Jacketed Cover, EPDM	1	E70261	
	O-Ring, Pump Jacketed Cover, FKM	1	V70261	
	O-Ring, Pump Jacketed Cover, Silicone	1	S75261	
37	Stop Pin, Seal	6	101719+	
39	Lockwasher, Gear	2	CD0036 W00	
41	Locknut, Gear	2	CD0036 N00	
42	Gear Case Shim, CI	1	040110000+	
	Gear Case Shim, SS; Optional	1	102285+	
	Pump Pedestal, 6.25", Optional	1	BD0110SM0	
43	Plastic Cap Plug, 3/8"	8	000121002+	
44	3/8-16 x 1" SHCS	4	30-189	
45	030,034-U2 Body Retaining Screw, 1/4-20 x 2"	2	30-211	
	040-U2 Body Retaining Screw, 1/4-20 x 2.5"	2	30-543	
46	Eye Bolt, 3/8-16 x 1.0" ZP 2	2	30-723	
47	Key, Coupling - 1/4 x 1/4 x 1-3/4"	1	000037002+	
	Key, Coupling - Tru-Fit	1	119715+	
48	Cleanout Plug	2	41013+	15
61	Name Plate, Sanitary	1	135624+	
62	#2 x .187" RHDS	4	30-355	
65	Caution Plate	2	121694+	
66	Warning Label	2	33-63	
67	030-U2 and 040-U2 Grease Fitting, 1/8"	4	BD0092000	1
	034-U2 Grease Fitting, 1/8"	4	BD0092100	2
68	Plastic Cap, Grease Fitting	4	BD0093000	

Notes:

* Recommended spare parts

- This grease fitting is the straight style. Part number BD0092100 is the angled style.
- This grease fitting is the angled style. Part number BD0092000 is the straight style.
- For bearing retainer for SS gear case or for bearing isolator, for bearing isolator kit, and for pumps manufactured prior to July 2004, see page 113.
- For an older gear case without a threaded plug hole, use plug p/n 000121002+.
- For seals, see page 102.
- For vented covers, see page 114.
- For shaft & bearing assembly part numbers, see page 112.

045, 060, 064, 130, 134-U2 Pump Parts

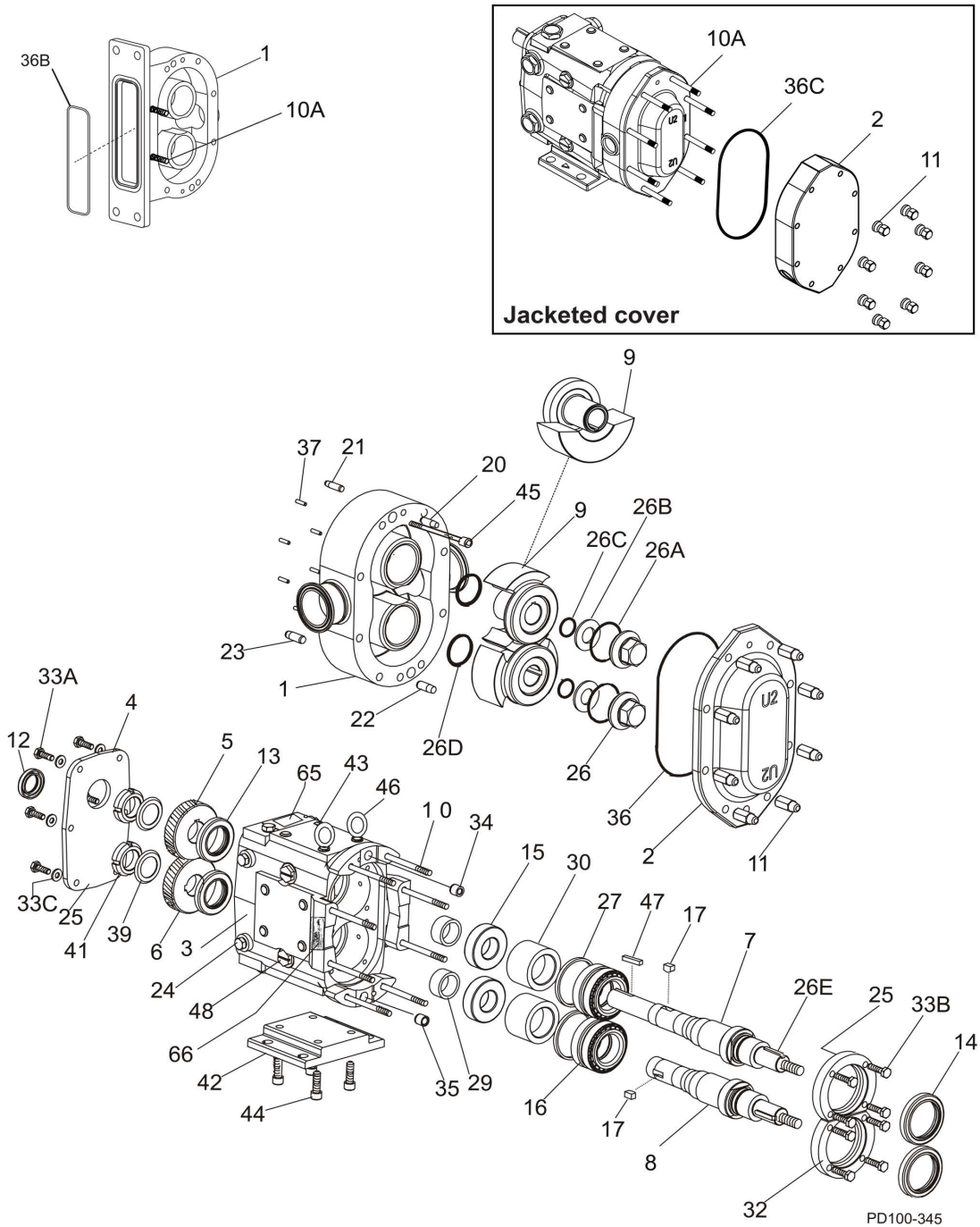

Notes: (See "Notes" column on page 79)

1. Contact customer service with serial number of pump for part number.
2. Standard clearances and finishes for rotor part numbers shown. Contact customer service for optional clearances and finishes.
3. Gear case assemblies listed are upper drive, side mount left hand, and include shafts and timing gears. CI assemblies are painted WCB blue. Contact customer service for other options.
4. Please contact the SPX Flow Customer Service for Gear Case options.
12. Replaces (obsolete) P/Ns 104728 (straight) and 104857 (90 degree) rotors.
- 12A. Replaces (obsolete) P/Ns 104746 (straight) and 104875 (90 degree) rotors.
13. Single wing rotors cannot be used with Rectangular Flange Inlet Pumps.
41. Tru-Fit drive shaft is longer than the standard drive shaft listed here. See page 116.
46. For Tru-Fit parts, see page 116. For shaft & bearing assembly part numbers, see page 112.

045, 060, 064, 130, 134-U2 Pump Parts

ITEM NO.	DESCRIPTION	QTY PER PUMP	PART NO.	NOTES
1	045-U2 Pump Body	1	See Note 1	1
	045-U2 Pump Body with Flush	1	See Note 1	1
	060-U2 Pump Body	1	See Note 1	1
	060-U2 Pump Body with Flush	1	See Note 1	1
	064-U2 Rectangular Flange Inlet Body	1	See Note 1	1
	064-U2 Rect. Flange Inlet Body with Flush	1	See Note 1	1
	130-U2 Pump Body	1	See Note 1	1
	130-U2 Pump Body with Flush	1	See Note 1	1
	134-U2 Rectangular Flange Inlet Body	1	See Note 1	1
	134-U2 Rect. Flange Inlet Body with Flush	1	See Note 1	1
3	Gear Case Assembly, CI, Model 045	1	POA	3, 4
	Gear Case Assembly, SS; Model 045 (Optional)	1	POA	3, 4
	Gear Case Assembly, CI, Model 060	1	POA	3, 4
	Gear Case Assembly, SS; Model 060 (Optional)	1	POA	3, 4
	Gear Case Assembly, CI, Model 064	1	POA	3, 4
	Gear Case Assembly, CI, Model 130	1	POA	3, 4
	Gear Case Assembly, SS; Model 130 (Optional)	1	POA	3, 4
	Gear Case Assembly, CI, Model 134	1	POA	3, 4
7	045-U2 Drive Shaft	1	110021+	41
	060-064-U2 Drive Shaft	1	108411+	41
	130-134-U2 Drive Shaft	1	108413+	41
8	045-U2 Short Shaft	1	110022+	
	060-064-U2 Short Shaft	1	108412+	
	130-134-U2 Short Shaft	1	108414+	
9	045-U2 Rotor, Twin Wing, Alloy 88	2	107252+	2
	045-U2 Rotor, Twin Wing, 316SS	2	107264+	2
	045-U2 Rotor, Single Wing, Alloy 88	2	117105+	2, 13
	060-064-U2 Rotor, Twin Wing, Alloy 88	2	102163+	2
	060-064-U2 Rotor, Twin Wing, 316SS	2	102226+	2
	060-U2 Rotor, Single Wing, Alloy 88	2	117117+	2, 12, 13
	130-134-U2 Rotor, Twin Wing, Alloy 88	2	102175+	2
	130-134-U2 Rotor, Twin Wing, 316SS	2	102232+	2
	130-U2 Rotor, Single Wing, Alloy 88	2	117129+	2, 12A, 13
10	045-U2 Stud	8	107242+	
10	060-U2 Stud	8	108843+	
10	064-U2 Stud	6	108843+	
	064-U2 Stud	2	OC1050000	
10	130-U2 Stud	8	101722+	
10	134-U2 Stud	6	101722+	
	134-U2 Stud	2	OC1050000	
10A	045-U2 Stud, Jacketed Cover	8	111584+	
10A	060-U2 Stud, Jacketed Cover	8	108846+	
10A	064-U2 Stud, Jacketed Cover	6	108846+	
	064-U2 Stud, Jacketed Cover	2	35556+	
10A	130-U2 Stud, Jacketed Cover	8	130011001+	
10A	134-U2 Stud, Jacketed Cover	6	130011001+	
	134-U2 Stud, Jacketed Cover	2	35556+	

Notes: See "Notes" on page 78

045, 060, 064, 130, 134-U2 Common Parts

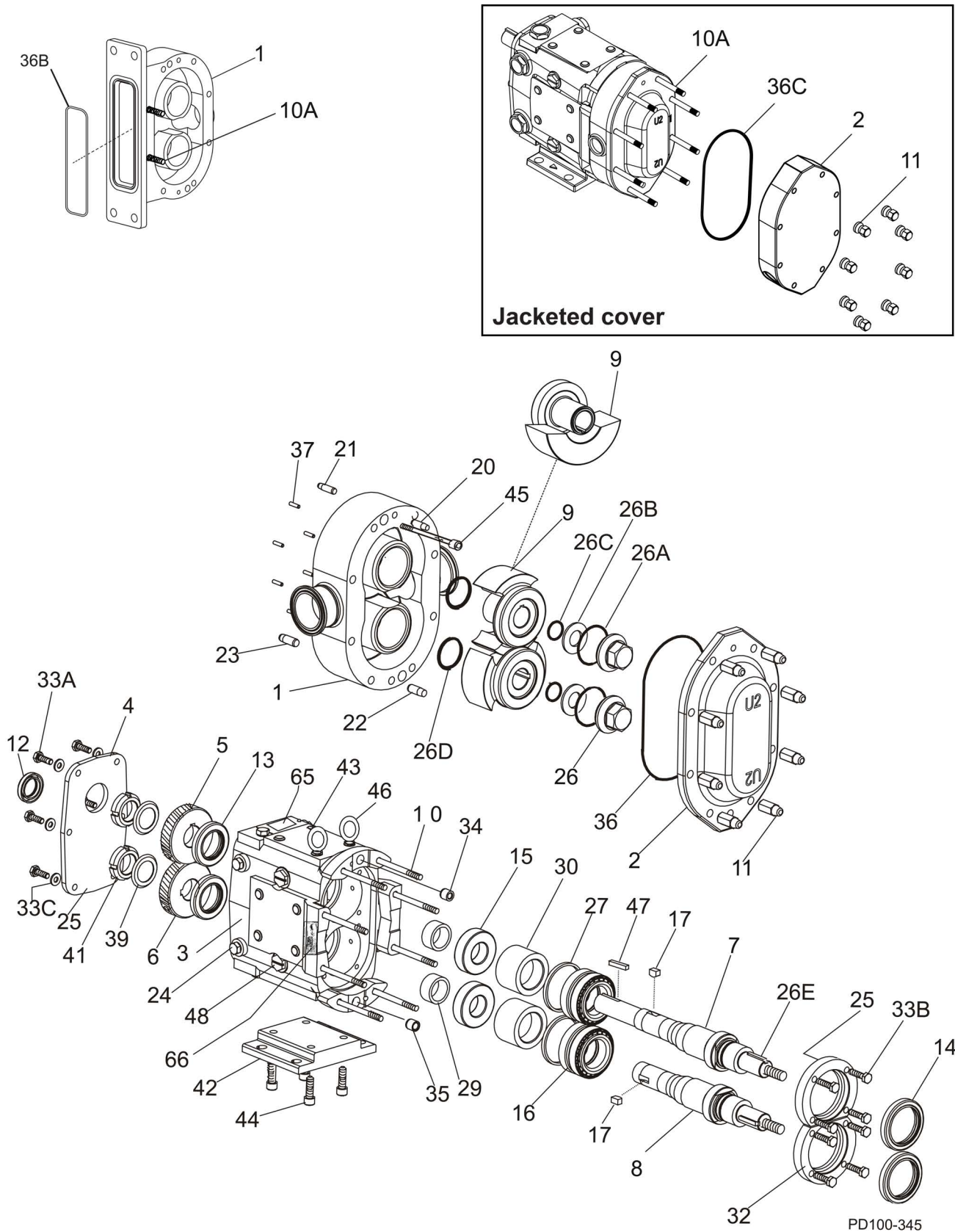

045, 060, 064, 130, 134-U2 Common Parts

ITEM NO.	DESCRIPTION	QTY. PER PUMP	PART NO.	NOTES
2	Pump Cover	1	101848+	
	Pump Cover	1	0301106-01+	48
2A	Jacketed Cover	1	107668+	
	Jacketed Cover	1	0300542+	49
2	Pump Cover Vented - Complete Assembly	1	POA	1
4	Gear Case Cover, Steel	1	070106000+	
	Gear Case Cover, SS; Optional	1	102282+	
5	Gear, Drive Shaft, Spur	1	107404+	
6	Gear, Short Shaft, Spur	1	107404+	
11	Hex Nut	8	108371+	
	Wing Nut, Optional	8	105852+	
12	Oil Seal, Gear Case Cover	1	000030012+	
13	Oil Seal, Gear Case Rear	2	000030011+	
14	Grease Seal, Bearing Retainer	2	101829+	3
15	Bearing, Rear	2	107186+	2
16	Bearing, Front	2	060036000+	
17	Key, Gear	2	060037000+	
20	Dowel Pin, Cover Side, .308" x .85"	1	137002+	43
21	Dowel Pin, Gear Case Side, .433" x 1.0"	1	124584+	44
22	Dowel Pin, Cover Side, .370" x .85"	1	137003+	43
23	Dowel Pin, Gear Case Side, .495" x 1.0"	1	124586+	44
24	Oil Plug, M20 x 1.5"	5	115798+	40
	Oil Level Indicator, M20 x 1.5"	1	115799+	40
	Oil Level Indicator, SS, M20 x 1.5"	1	137435+	
	Oil Level Indicator, ATEX, M20 x 1.5	1	131417+	
25	Silicone Sealant	1	000142301+	
26	Nut, Rotor	2	101806+	
26A*	O-Ring, Rotor Nut, Buna N	2	N70227	
	O-Ring, Rotor Nut, EPDM	2	E70227	
	O-Ring, Rotor Nut, FKM	2	V70227	
26B*	Belleville Washer	2	101693+	
26C*	O-Ring, Retainer, Buna N	2	N70119	
	O-Ring, Retainer, EPDM	2	E70119	
	O-Ring, Retainer, FKM	2	V70119	
26D*	O-Ring, Rotor Hub, Buna N	2	N70224	
	O-Ring, Rotor Hub, EPDM	2	E70224	
	O-Ring, Rotor Hub, FKM	2	V70224	
26E*	045-U2 Key, Rotor	2	110926+	
	060-064-U2 Key, Rotor	2	101823+	
	130-134-U2 Key, Rotor	2	101825+	
27	Shim Kit	2	117891+	

Notes:

* Recommended spare parts

- Please configure in eSales or contact customer service.
- Pumps shipped appx. 12/1999 and earlier, see "045, 060, 130-U2 Rear Bearing and Spacer" on page 85.
- For bearing isolator kit, see page 113.
- Applies to pumps shipped after October 2003. Pumps shipped prior to October 2003 used qty 6 of plug w/washer, part number 000046004+.
- Exposed length of dowel pin: .444" (11.3 mm)
- Exposed length of dowel pin: .563" (14.3 mm)
- For shaft & bearing assembly part numbers, see page 112.
- Pump cover are available from Sept 25, 2023
- Jacketed cover are available from July 13, 2023.

045, 060, 064, 130, 134-U2 Common Parts, cont'd

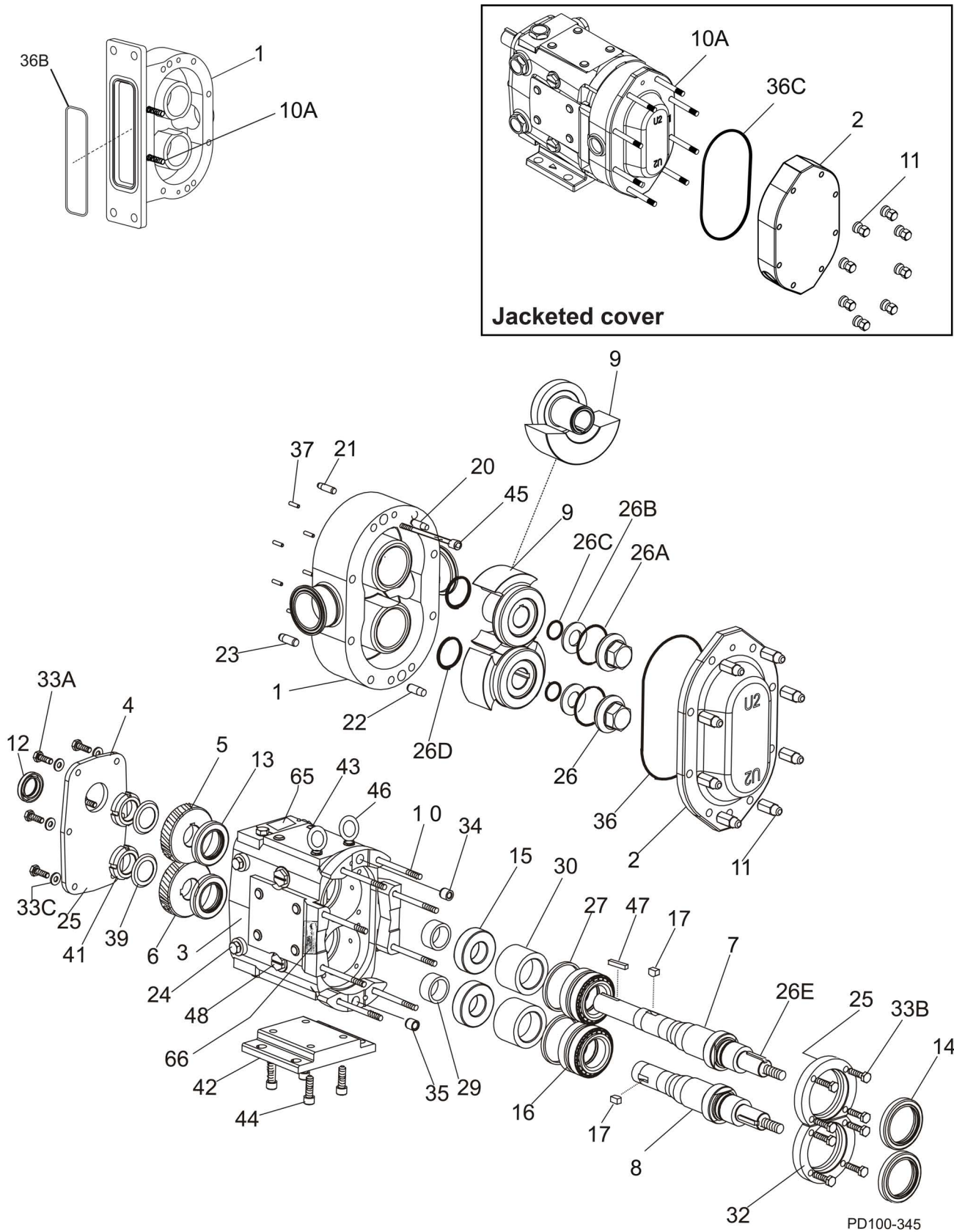

PD100-345

045, 060, 064, 130, 134-U2 Common Parts, cont'd

ITEM NO.	DESCRIPTION	QTY. PER PUMP	PART NO.	NOTES
29	Spacer, Gear to Rear Bearing	2	107187+	2
30	Bearing Spacer	2	060055003+	
31	Grease Retainer, Rear Bearing	2	STD091002	
32	Bearing Retainer, Front, CTD	2	123531+	5, 7
	Bearing Retainer, Front SS, for std. lip seal	2	121828+	6, 7
	Bearing Retainer, Front SS, used with bearing isolators.	2	101812+	6, 7
33A	3/8-16 x 3/4" HHCS, SS Gear Case Cover	6	30-50	
33B	3/8-16 x 1-1/4" HHCS, SS Bearing Retainer	8	30-60	
33C	3/8" Flat Washer, Gear Case Cover	6	43-30	
34	Dowel Bushing, Upper	1	CD0116000	
35	Dowel Bushing, Lower	1	CD0116 100	
36*	O-Ring, Pump Cover, Buna N	1	N70373	
	O-Ring, Pump Cover, EPDM	1	E70373	
	O-Ring, Pump Cover, FKM	1	V70373	
	O-Ring, Pump Cover, Silicone	1	S75373	
36B*	064-U2 O-Ring, Rectangular Flange, Buna N	1	N70366	
	064-U2 O-Ring, Rectangular Flange, EPDM	1	E70366	
	064-U2 O-Ring, Rectangular Flange, FKM	1	V70366	
	134-U2 O-Ring, Rectangular Flange, Buna N	1	N70369	
	134-U2 O-Ring, Rectangular Flange, EPDM	1	E70369	
	134-U2 O-Ring, Rectangular Flange, FKM	1	V70369	
36C*	O-Ring, Pump Jacketed Cover, Buna N	1	N70272	
	O-Ring, Pump Jacketed Cover, EPDM	1	E70272	
	O-Ring, Pump Jacketed Cover, FKM	1	V70272	
	O-Ring, Pump Jacketed Cover, Silicone	1	S75272	
37	Stop Pin, Seal	6	101720+	
39	Lockwasher, Gear	2	STD136009	
41	Locknut, Gear	2	STD236009	
42	Gear Case Shim, CI	1	070110000+	
	Gear Case Shim, SS; Optional	1	102286+	
	Pump Pedestal, 5.5", Optional	1	CD0110SM5	
	Pump Pedestal, 10", Optional	1	CD0110SM1	
43	Plastic Cap Plug	6	000121001+	
44	1/2-13 x 1-1/4" SS SHCS	4	30-503	
45	045-U2 Body Retaining Screws, 5/16-8 x 2-1/2"	2	30-615	
	060-064-U2 Body Retaining Screws, 5/16-8 x 3"	2	30-319	
	130-134-U2 Body Retaining Screws, 5/16-8 x 4"	2	30-423	

Notes:

* Recommended spare parts

2. Pumps shipped appx. 12/1999 and earlier, see "045, 060, 130-U2 Rear Bearing and Spacer" on page 85.
5. 123531+ is available until stock is depleted, then will be replaced by 121828+. CTD = Coated Steel
6. 101812+ is used with bearing isolators; for std. lip seal, use part # 121828+. SS = Stainless Steel
7. For bearing isolator kit, and for pumps older than 7/12/04, see page 113.
16. For seals, see page 102.
17. For vented covers, see page 114.
47. For shaft & bearing assembly part numbers, see page 112.

045, 060, 064, 130, 134-U2 Common Parts, cont'd

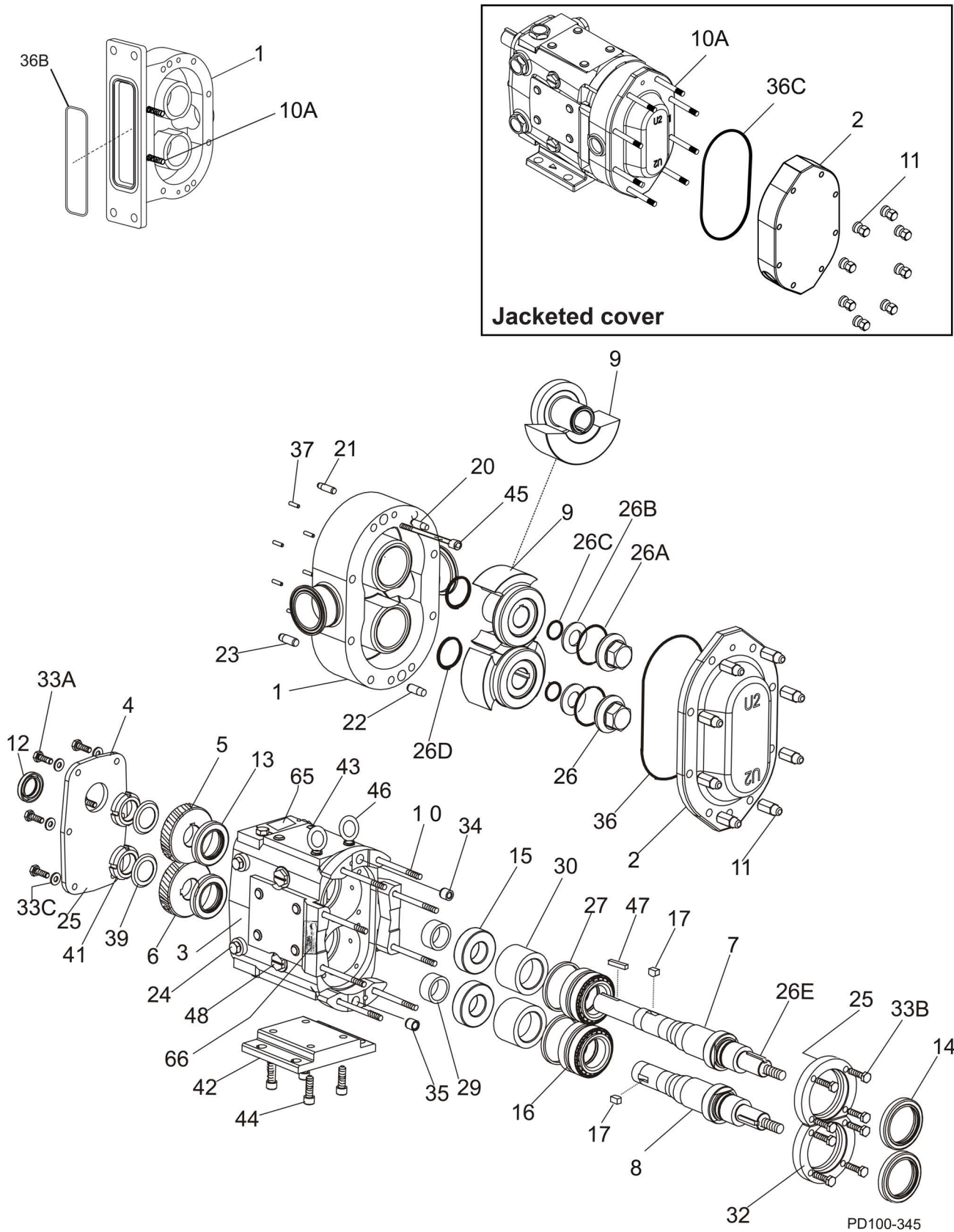

045, 060, 064, 130, 134-U2 Common Parts, cont'd

ITEM NO.	DESCRIPTION	QTY. PER PUMP	PART NO.	NOTES
46	Eye Bolt, 1/2 -13	2	30-360	
47	Key, Coupling - 3/8 x 3/8 x 1-5/8"	1	000037003+	
	Key, Coupling - Tru-Fit	1	119716+	
48	Cleanout Plug	2	41013+	15
61	Name Plate, Sanitary	1	135624+	
62	#2 x .187" RHDS	4	30-355	
65	Caution Plate	2	121694+	
66	Warning Label	2	33-60	
67	045-060-130-U2 Grease Fitting, 1/8" (straight)	4	BD0092000	
	064-134-U2 Grease Fitting, 1/8" (angled)	4	BD0092 100	
68	Plastic Cap, Grease Fitting	4	BD0093000	

Notes:

15. For an older gear case without a threaded plug hole, use plug p/n 000121001+

045, 060, 130-U2 Rear Bearing and Spacer

Item No.	Description	Part no. for pumps manufactured:		Qty per pump
		before 12/1999	after 12/1999 (New)	
15	Bearing, Rear	060 035 000 (obsolete); use 107186+ with 107187+ (see kit 107188+)	107186+	2
29	Spacer, Gear to Rear Bearing	060055000+; use only with existing bearing 060 035 000 (obsolete)	107187+	2
N/A	Bearing and Spacer Kit (107186+ x1 and 107187+ x1)	107188+: use if replacing (obsolete) rear bearing 060 035 000	-	2

Notes:

- When replacing the obsoleted rear bearing 060 035 000 with new rear bearing 107186+, you must also replace the old shorter gear spacer 060055000+, with new longer gear spacer 107187+. See note 2.
- The 107188+ kit consists of one rear bearing 107186+ and one gear spacer 107187+, which have replaced obsoleted rear bearing 060 035 000 and old gear spacer 060055000+.
- The old 060055000+ gear spacer was used in pumps before 12/1999. It is available as a service part only for use with existing (obsolete) bearing 060 035 000. It will not fit with new rear bearing 107186+.
- Dates listed are estimates. To confirm part number, contact customer service and provide serial number.

180, 184, 220, 224-U2 Pump Parts

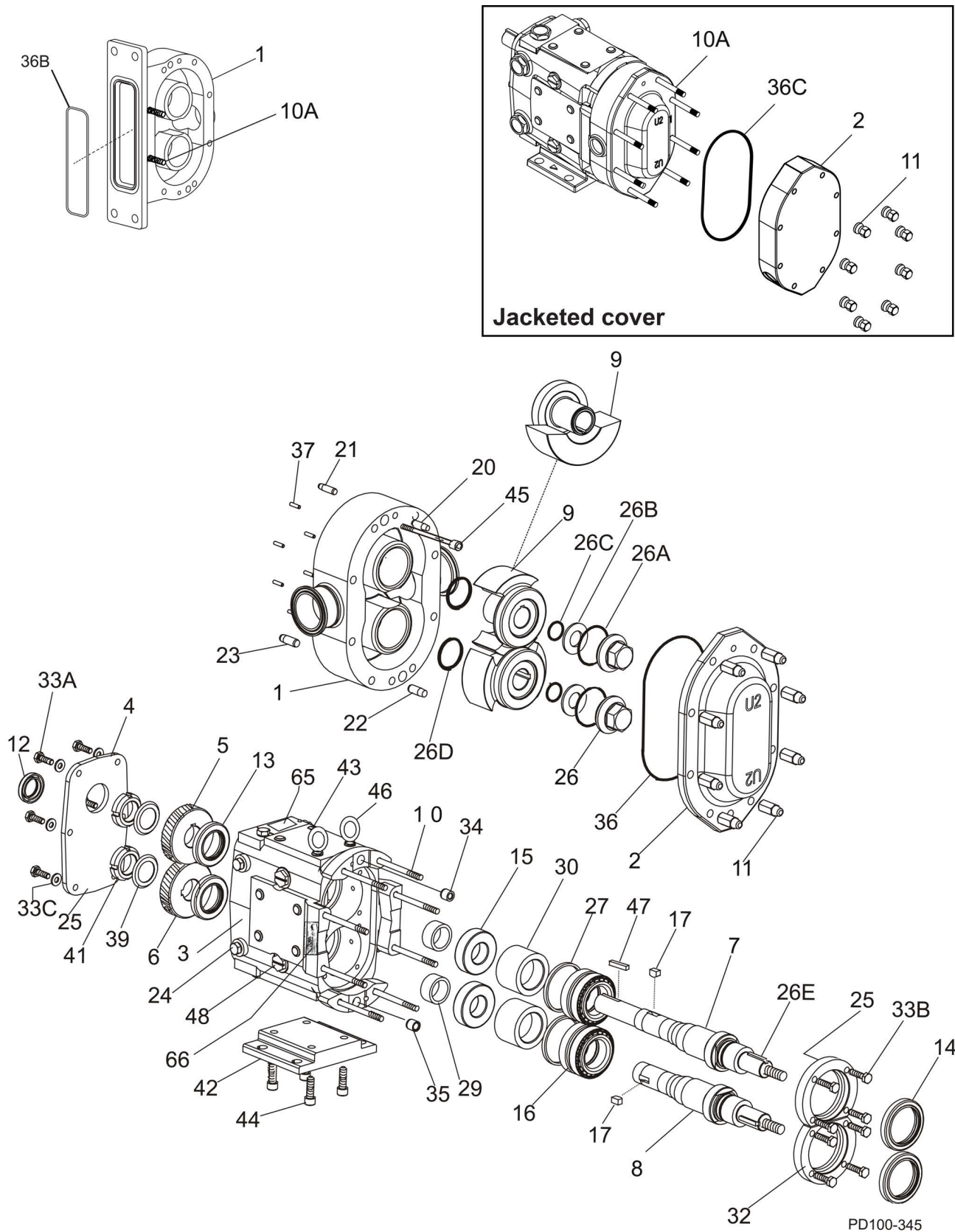

180, 184, 220, 224-U2 Pump Parts

ITEM NO.	DESCRIPTION	QTY. PER PUMP	PART NO.	NOTES
1	180-U2 Pump Body	1	See Note 1	1
	180-U2 Pump Body with Flush	1	See Note 1	1
	184-U2 Pump Body	1	See Note 1	1
	184-U2 Pump Body with Flush	1	See Note 1	1
	220-U2 Pump Body	1	See Note 1	1
	220-U2 Pump Body with Flush	1	See Note 1	1
	224-U2 Rectangular Flange Inlet Body	1	See Note 1	1
	224-U2 Rect. Flange Inlet Body with Flush	1	See Note 1	1
3	Gear Case Assembly, CI, Model 180-184	1	POA	3, 4
	Gear Case Assembly, SS; Model 180-184 (Optional)	1	POA	3, 4
	Gear Case Assembly, CI, Model 220	1	POA	3, 4
	Gear Case Assembly, SS; Model 220 (Optional)	1	POA	3, 4
	Gear Case Assembly, CI, Model 224	1	POA	3, 4
7	180-184-U2 Drive Shaft	1	110023+	41
	220-224-U2 Drive Shaft	1	108415+	41
8	180-184-U2 Short Shaft	1	110024+	
	220-224 Short Shaft	1	108416+	
9	180-184-U2 Rotor, Twin Wing, Alloy 88	2	107273+	2
	180-184-U2 Rotor, Twin Wing, 316SS	2	107285+	2
	220-224 -U2 Rotor, Twin Wing, Alloy 88	2	102187+	2
	220-224 -U2 Rotor, Twin Wing, 316SS	2	102238+	2
	220-U2 Single Wing, Alloy 88	2	117141+	2, 12, 13
10	180-U2 Stud	8	107243+	
10	184-U2 Stud	6	107243+	
	184-U2 Stud	2	35550+	
10	220-U2 Stud	8	108844+	
10	224-U2 Stud	6	108844+	
	224-U2 Stud	2	35550+	
10A	180-U2 Stud, Jacketed Cover	8	112629+	
10A	180-U2 Stud, Standard jacketed Cover	8	138627+	45
10A	184-U2 Stud, Jacketed Cover	6	112629+	
	184-U2 Stud, Jacketed Cover	2	36144+	
10A	184-U2 Stud, Standard jacketed Cover	8	138627+	45
10A	184-U2 Stud, Short Jacketed Cover	8	141498+	45
10A	220-U2 Stud, Jacketed Cover	8	108847+	
10A	224-U2 Stud, Jacketed Cover	6	108847+	
	224-U2 Stud, Jacketed Cover	2	36144+	
10A	224-U2 Stud, Short Jacketed Cover	8	141498+	45

Notes:

- Contact customer service with serial number of pump for part number.
- Standard clearances and finishes for rotor part numbers shown. Contact customer service for optional clearances and finishes.
- Gear Case Assemblies listed are upper drive, side mount left hand, and include shafts and timing gears. CI assemblies are painted WCB blue. Contact customer service for other options.
- Please contact the SPX Flow Customer Service for Gear Case options.
- Replaces (obsolete) P/Ns 104764 (straight) and 104893 (90 degree) rotors.
- Single wing rotors cannot be used with rectangular flange inlet pumps.
- Tru-Fit drive shaft is longer than the standard drive shaft listed here. See page 116.
- Studs to be installed with a jacketed cover (0300592+).
- For shaft & bearing assembly part numbers, see page 112.

180, 184, 220, 224-U2 Common Parts

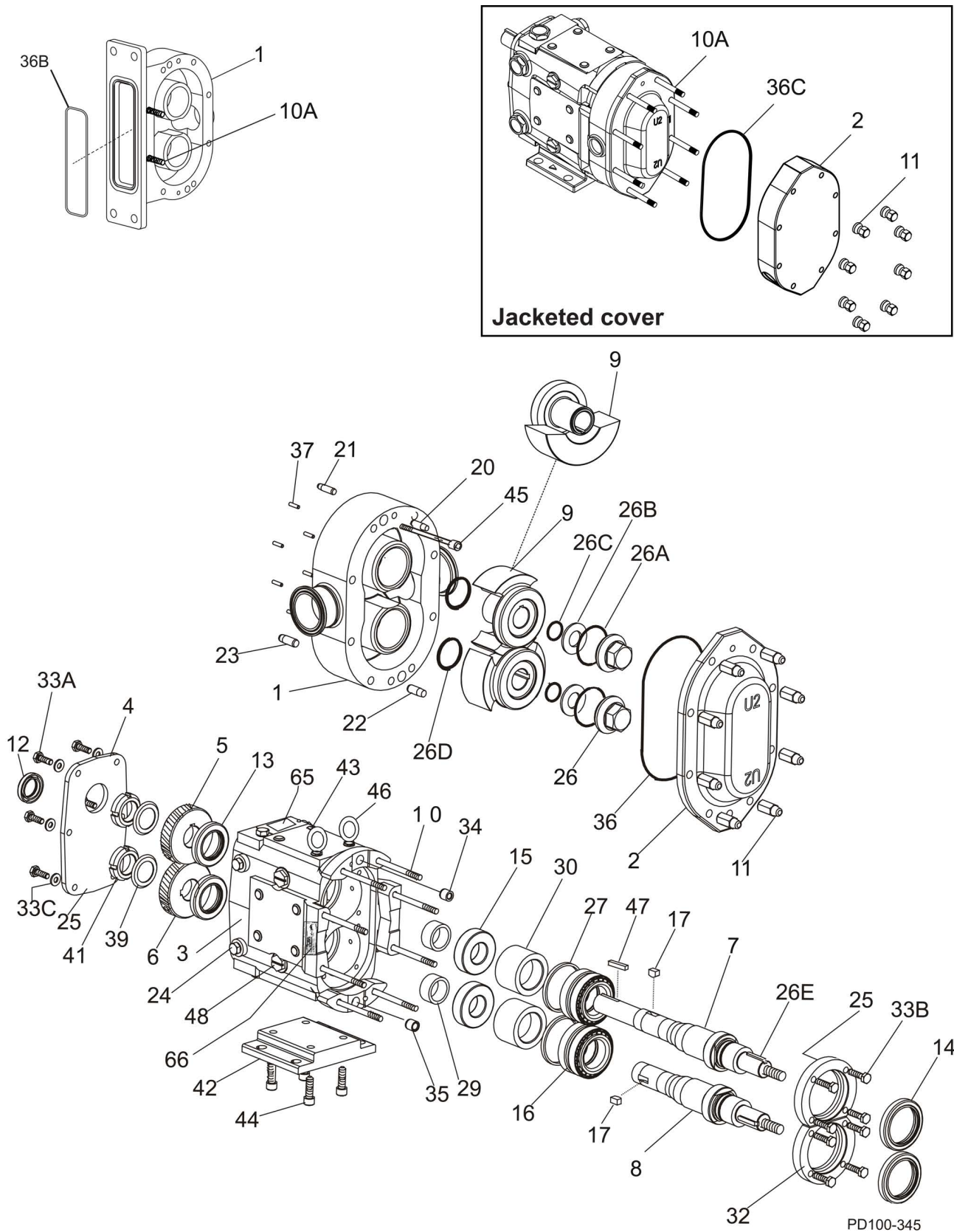

180, 184, 220, 224-U2 Common Parts

ITEM NO.	DESCRIPTION	QTY. PER PUMP	PART NO.	NOTES
2	Pump Cover	1	101851+	
	Pump Cover	1	0301109-01+	48
2A	Jacketed Cover	1	107670+	
	Jacketed Cover	1	0300592+	49
2	Pump Cover Vented - Complete Assembly	1	POA	1
4	Gear Case Cover, Steel	1	230106000+	
	Gear Case Cover, SS; Optional	1	102283+	
5	Gear, Drive Shaft, Spur	1	110932+	
6	Gear, Short Shaft, Spur	1	110932+	
11	Hex Nut	8	108372+	
	Wing Nut, Optional	8	105853+	
12	Oil Seal, Gear Case Cover	1	STD030006	
13	Oil Seal, Gear Case Rear	2	STD119002	
14	Grease Seal, Bearing Retainer	2	121681+	3
15	Bearing, Rear	2	200035000+	
16	Bearing, Front	2	200036000+	
17	Key, Gear	2	200037000+	
20	180-220-U2 Dowel Pin, Cover Side, .433" x .85"	1	137004+	43
	184-224-U2 Dowel Pin, Cover Side, .495" x .85"	1	137005+	43
21	180-220-U2 Dowel Pin, Gear Case Side, .433" x 1.0"	1	124584+	44
	184-224-U2 Dowel Pin, Gear Case Side, .495" x 1.0"	1	124586+	44
22	180-220-U2 Dowel Pin, Cover Side, .495" x .85"	1	137005+	43
	184-224-U2 Dowel Pin, Cover Side, .433" x .85"	1	137004+	43
23	180-220-U2 Dowel Pin, Gear Case Side, .495" x 1.0"	1	124586+	44
	184-224-U2 Dowel Pin, Gear Case Side, .433" x 1.0"	1	124584+	44
24	Oil Plug, M20 x 1.5"	5	115798+	40
	Oil Level Indicator, M20 x 1.5"	1	115799+	40
	Oil Level Indicator, SS, M20 x 1.5"	1	137435+	
	Oil Level Indicator, ATEX, M20 x 1.5	1	131417+	
25	Silicone Sealant	1	000142301+	
26	Nut, Rotor	2	101807+	
26A*	O-Ring, Rotor Nut, Buna N	2	N70235	
	O-Ring, Rotor Nut, EPDM	2	E70235	
	O-Ring, Rotor Nut, FKM	2	V70235	
26B*	Belleville Washer	2	101694+	
26C*	O-Ring, Retainer, Buna N	2	N70122	
	O-Ring, Retainer, EPDM	2	E70122	
	O-Ring, Retainer, FKM	2	V70122	
26D*	O-Ring, Rotor Hub, Buna N	2	N70230	
	O-Ring, Rotor Hub, EPDM	2	E70230	
	O-Ring, Rotor Hub, FKM	2	V70230	

Notes:

* Recommended spare parts

- Please configure in eSales or contact customer service.
- For bearing isolator kit, see page 113.
- Applies to pumps shipped after October 2003. Pumps shipped prior to October 2003 used qty 6 of plug w/washer, part number 000046004+.
- Exposed length of dowel pin: .444" (11.3 mm)
- Exposed length of dowel pin: .563" (14.3 mm)
- For shaft & bearing assembly part numbers, see page 112.
- Pump cover are available from May 30, 2023
- Jacketed cover are available from November 22, 2022.

180, 184, 220, 224-U2 Common Parts, cont'd

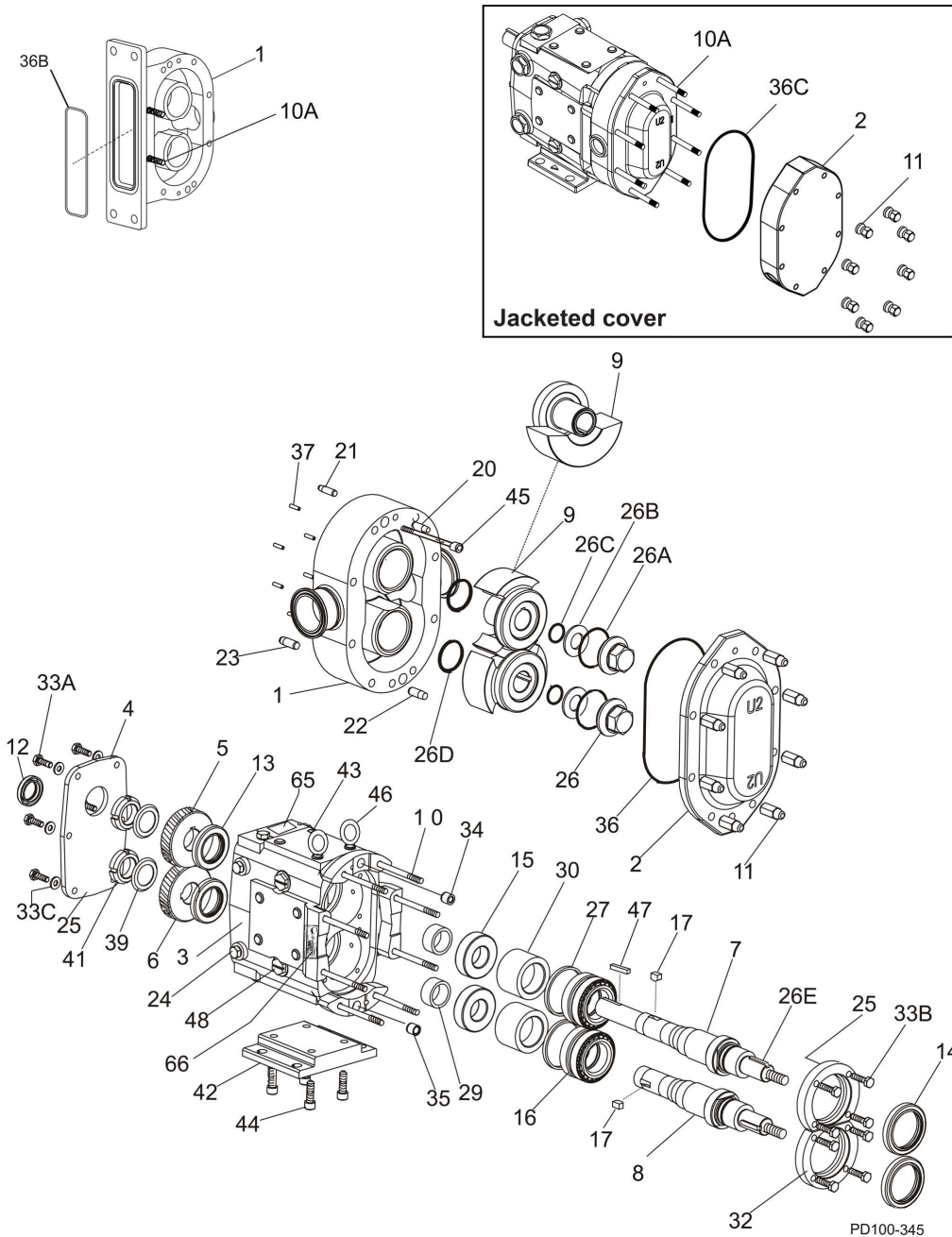

Notes: (See "Notes" column on page 91)

* Recommended Spare Parts

1. For pumps purchased before about 1990, replace both spacers, as 40878+ will not work correctly with the old design spacer (200055000).
3. For pumps manufactured after July 2004. For bearing isolator kit, and for pumps prior to July 2004, see page 113.
15. For an older gear case without a threaded plug hole, use plug p/n 000121001+
16. For seals, see page 102. For vented covers, see page 114.
47. For Shaft & Bearing assembly part numbers, see page 112.

180, 184, 220, 224-U2 Common Parts, cont'd

ITEM NO.	DESCRIPTION	QTY. PER PUMP	PART NO.	NOTES
26E	180-184-U2 Key, Rotor	2	101828+	
	220-224-U2 Key, Rotor	2	101827+	
27	Shim Kit	2	117892+	
29	Spacer, Gear to Rear Bearing	2	40878+	1
30	Bearing Spacer	2	40752+	
32	Bearing Retainer, Front, SS	2	121829+	3
	Bearing Retainer, Front, SS, used with bearing isolators	2	101813+	3
33A*	3/8-16 x 3/4" HHCS, SS Gear Case Cover	8	30-50	
33B*	3/8-16 x 1-1/4" HHCS, SS Bearing Retainer	8	30-60	
33C*	3/8" Flat Washer, Gear Case Cover	8	43-30	
34*	Dowel Bushing, Upper	1	CD0116000	
35*	Dowel Bushing, Lower	1	CD0116100	
36*	O-Ring, Pump Cover, Buna N	1	N70381	
	O-Ring, Pump Cover, EPDM	1	E70381	
	O-Ring, Pump Cover, FKM	1	V70381	
	O-Ring, Pump Cover, Silicone	1	S75381	
36B*	184-U2 O-ring, Rectangular Flange, Buna N	1	N70374	
	184-U2 O-ring, Rectangular Flange, EPDM	1	E70374	
	184-U2 O-ring, Rectangular Flange, FKM	1	V70374	
	224-U2 O-Ring, Rectangular Flange, Buna N	1	N70376	
	224-U2 O-Ring, Rectangular Flange, EPDM	1	E70376	
	224-U2 O-Ring, Rectangular Flange, FKM	1	V70376	
36C*	O-Ring, Pump Jacketed Cover, Buna N	1	GD0117000	
	O-Ring, Pump Jacketed Cover, EPDM	1	GD0117002	
	O-Ring, Pump Jacketed Cover, FKM	1	GD0117V00	
	O-Ring, Pump Jacketed Cover, Silicone	1	GD0117SC0	
37	Stop Pin, Seal	6	101720+	
39	Lockwasher, Gear	2	STD136011	
41	Locknut, Gear	2	STD236011	
42	Gear Case Shim, CI	1	230110000+	
	Gear Case Shim, SS; Optional	1	102287+	
	Pump Pedestal, 9", Optional	1	GD0110SM9	
	Pump Pedestal, 13", Optional	1	GD0110SM1	
43	Plastic Cap Plug	6	000121001+	
44	1/2-13 x 2" SS SHCS	4	30-44	
45	180-184-U2 Body Retaining Screws, 3/8-16 x 4"	2	30-323	
	220-224-U2 Body Retaining Screws, 3/8-16 x 4-1/2"	2	30-499	
46	Eye Bolt, 1/2 -13	2	30-360	
47	Key, Coupling - 1/2 x 1/2 x 1-7/8"	1	000037004+	
	Key, Coupling - Tru-Fit	1	119717+	
48	Cleanout Plug	2	41013+	15
61	Name Plate, Sanitary	1	001061015+	
62	#2 x .187" RHDS	4	30-355	
65	Caution Plate	2	121694+	
66	Warning Label	2	33-60	
67	180-184-220-U2 Grease Fitting, 1/8" (straight)	4	BD0092000	
	224-U2 Grease Fitting, 1/8" (angled)	4	BD0092100	
68	Plastic Cap, Grease Fitting	4	BD0093000	

Notes: See page 90.

210, 213, 214, 320, 323, 324, 370-U2 Pump Parts

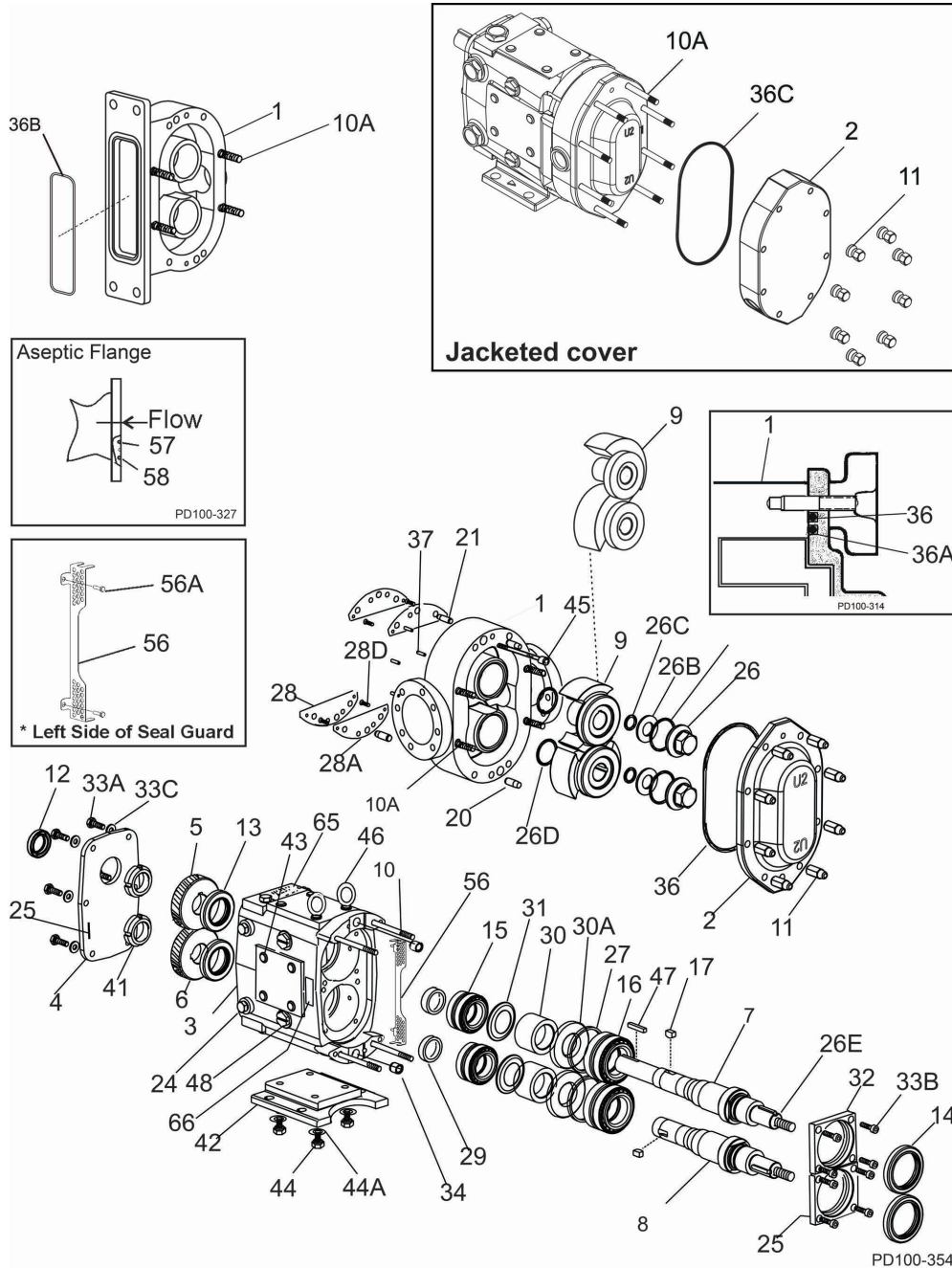

Notes (see "Notes" column on page 93):

1. Contact customer service with serial number of pump for part number.
2. Standard clearances and finishes for rotor part numbers shown. Contact customer service for optional clearances and finishes.
3. Gear case assemblies listed are upper drive, side mount left hand, and include shafts and timing gears. CI assemblies are painted WCB blue. Contact customer service for other options.
4. Please contact the SPX Flow Customer Service for Gear Case options.
12. Replaces (obsolete) P/Ns 107662 (straight) and 107663 (90 degree) rotors.
41. Tru-Fit drive shaft is longer than the standard drive shaft listed here. See page 116.
45. Studs to be installed with a jacketed cover (0300595+).
47. For shaft & bearing assembly part numbers, see page 112.

210, 213, 214, 320, 323, 324, 370-U2 Pump Parts

ITEM NO.	DESCRIPTION	QTY. PER PUMP	PART NO.	NOTES
1	210-U2 Pump Body	1	See Note 1	1
	210-U2 Pump Body with Flush	1	See Note 1	1
	213-U2 Pump Body	1	See Note 1	1
	214-U2 Pump Body	1	See Note 1	1
	214-U2 Pump Body with Flush	1	See Note 1	1
	320-U2 Pump Body	1	See Note 1	1
	320-U2 Pump Body with Flush	1	See Note 1	1
	323-U2 Pump Body	1	See Note 1	1
	324-U2 Pump Body	1	See Note 1	1
	324-U2 Pump Body with Flush	1	See Note 1	1
	370-U2 Pump Body	1	See Note 1	1
	370-U2 Pump Body with Flush	1	See Note 1	1
3	Gear Case Assembly, CI, Model 210-213	1	POA	3, 4
	Gear Case Assembly, CI, Model 214	1	POA	3, 4
	Gear Case Assembly, CI, Model 320-323-370	1	POA	3, 4
	Gear Case Assembly, CI, Model 324	1	POA	3, 4
7	210-214-U2 Drive Shaft	1	112186+	41
	213-U2 Drive Shaft	1	112188+	41
	320-324-U2 Drive Shaft	1	108417+	41
	323-U2 Drive Shaft	1	113960+	41
	370-U2 Drive Shaft	1	124839+	41
8	210-214-U2 Short Shaft	1	112187+	
	213-U2 Short Shaft	1	112189+	
	320-324-U2 Short Shaft	1	108418+	
	323-U2 Short Shaft	1	113961+	
	370-U2 Short Shaft	1	124840+	
9	210-213-214-U2 Rotor, Twin Wing, Alloy 88	2	112199+	2
	210-213-214-U2 Rotor, Twin Wing, 316SS	2	112211+	2
	210-213-214-U2 Rotor, Single Wing, Alloy 88	2	117220+	2
	320-324-U2 Rotor, Twin Wing, Alloy 88	2	105427+	2
	320-324-U2 Rotor, Twin Wing, 316SS	2	105439+	2
	320-324-U2 Rotor, Single Wing, Alloy 88	2	117153+	2, 12
	323-U2 Rotor, Twin Wing, Alloy 88	2	114022+	2
	370-U2 Rotor, Twin Wing, Alloy 88	2	124849+	2
370-U2 Rotor, Twin Wing, 316SS	2	124861+	2	
10	210-213-214-U2 Stud, Long	4	112191+	
	320-323-324-U2 Stud, Long	4	111291+	
	370-U2 Stud, Long	4	124838+	
10	214-324-U2 Stud, Short	2	111292+	
		2	40699+	
	210-213-320-323-370-U2 Stud, Short	4	111292+	
10A	210-214-U2 Stud, Standard Jacketed Cover	8	138342+	45
10A	210-214-U2 Stud, Short Jacketed Cover	8	306946+	45
10A	214-324-U2 Stud, Jacketed Cover	8	306862+	
10A	320-324-U2 Stud, Standard Jacketed Cover	8	141277+	45
10A	320-324-U2 Stud, Short Jacketed Cover	8	306946+	45
10A	370-U2 Stud, Standard Jacketed Cover	8	306950+	
10A	370-U2 Stud, Short Jacketed Cover	8	306946+	45

Notes: See page 92.

210, 213, 214, 320, 323, 324, 370-U2 Common Parts

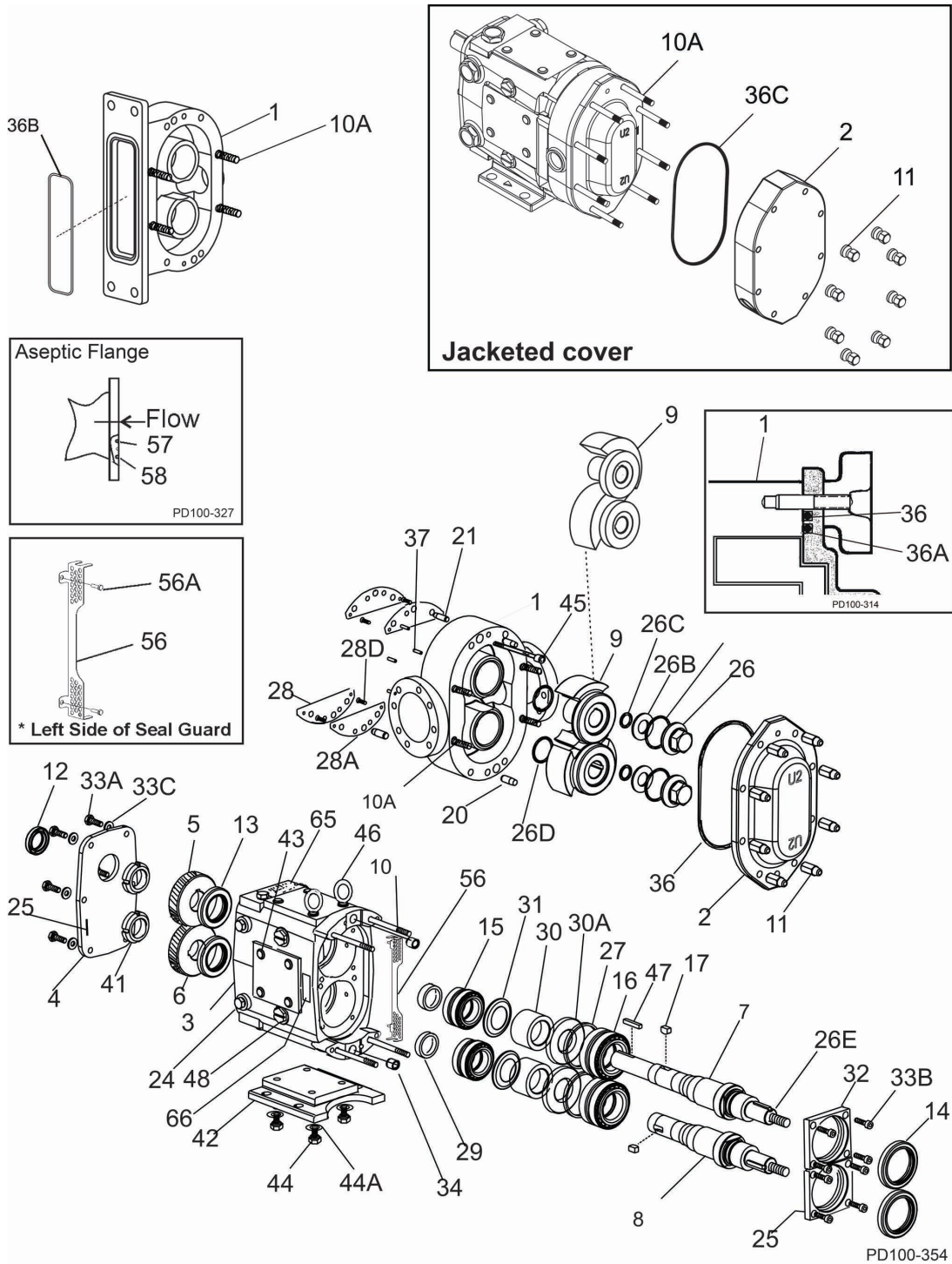

Notes (see "Notes" column on page 95):

* Recommended spare parts

- 3. Applies to pumps shipped after July 2001. Prior to this date, this part was not required. Check the pump serial number to verify the date of manufacture and identify the part number required.
- 4. For pumps manufactured after July 2004. For bearing isolator kit, and for pumps prior to July 2004, see page 113.
- 40. Applies to pumps shipped after October 2003. Pumps shipped prior to October 2003 used qty 6 of plug with washer, part number 000046004+.
- 43. Exposed length of dowel pin: .75" (19 mm)
- 44. Exposed length of dowel pin: 1.125" (28.6 mm)
- 47. For shaft & bearing assembly part numbers, see page 112.
- 48. Pump cover are available from November, 2022
- 49. Jacketed cover are available from November 22, 2022.

210, 213, 214, 320, 323, 324, 370-U2 Common Parts

ITEM NO.	DESCRIPTION	QTY PER PUMP	PART NO.	NOTES
2	210-224-U2 Pump Cover	1	112865+	
	210-224-U2 Pump Cover	1	0301124-04+	48
2A	210-224-U2 Jacketed Cover	1	116342+	
	210-224-U2 Jacketed Cover	1	0300595+	49
2	320-324-370-U2 Pump Cover	1	109974+	
	320-324-370-U2 Pump Cover	1	0301124-01+	48
2A	320-324-370-U2 Jacketed Cover	1	114359+	
	320-324-370-U2 Jacketed Cover	1	0300595+	49
2	213-323-U2 Pump Cover	1	114020+	
	213-323-U2 Pump Cover	1	0301124-20+	48
4	Gear Case Cover, Steel	1	40669+	
5	Gear, Drive Shaft, Spur	1	102470+	
6	Gear, Short Shaft, Spur	1	102470+	
11	Hex Nut	8	108373+	
	Wing Nut, Optional	8	110858+	
12	Oil Seal, Gear Case Cover	1	STD030004	
13	Oil Seal, Gear Case Rear	2	102475+	3
14	Grease Seal, Bearing Retainer	2	121681+	4
15	Bearing, Rear	2	0H1036000	
16	Bearing, Front	2	0H1036003	
17	Key, Gear	2	0H1037000	
20	Dowel Pins, Cover Side	2	0H1040000	43
21	Dowel Pins, Gear Case Side	2	105871+	44
24	Oil Plug, M20 x 1.5"	5	115798+	40
	Oil Level Indicator, M20 x 1.5"	1	115799+	40
	Oil Level Indicator, SS, M20 x 1.5"	1	137435+	
	Oil Level Indicator, ATEX, M20 x 1.5	1	131417+	
25	Silicone Sealant	1	000142301+	
26	Nut, Rotor	2	105409+	
26A*	O-Ring, Rotor Nut, Buna N	2	N70237	
	O-Ring, Rotor Nut, EPDM	2	E70237	
	O-Ring, Rotor Nut, FKM	2	V70237	
	O-Ring, Rotor Nut, Silicone	2	S75237	
26B*	Washer, Belleville	2	105411+	
26C*	O-Ring, Retainer, Buna N	2	N70125	
	O-Ring, Retainer, EPDM	2	E70125	
	O-Ring, Retainer, FKM	2	V70125	
	O-Ring, Retainer, Silicone	2	S75125	
26D*	O-Ring, Rotor Hub, Buna N	2	N70232	
	O-Ring, Rotor Hub, EPDM	2	E70232	
	O-Ring, Rotor Hub, FKM	2	V70232	
	O-Ring, Rotor Hub, Silicone	2	S75232	
26E	210-213-224-U2 Key, Rotor	2	105422+	
	320-323-324-370-U2 Key, Rotor	2	105421+	
27	Shim Kit	2	117893+	

Notes: See page 94.

210, 213, 214, 320, 323, 324, 370-U2 Common Parts, cont'd

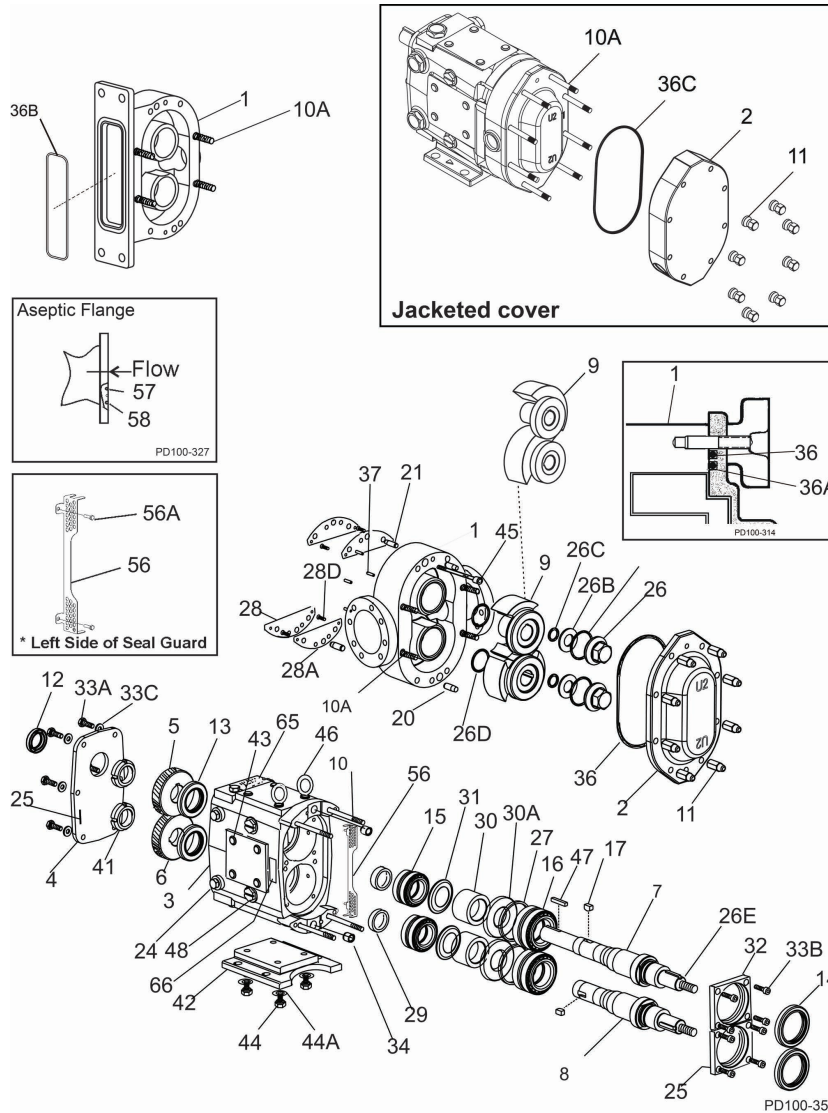

ITEM NO.	DESCRIPTION	QTY. PER PUMP	PART NO.	NOTES
28	Shim Plate	2	105426+	
28A	Shims, Body, .002	AR	105866+	
	Shims, Body, .003	AR	105867+	
	Shims, Body, .005	AR	105868+	
	Shims, Body, .010	AR	105869+	
	Shims, Body, .020	AR	105870+	
28D	5/16-18 x 1" FHSCS	4	30-612	

Notes: (See "Notes" column on page 97)

* Recommended spare parts

3. Pumps shipped prior to July 30, 2001.

4. Pumps shipped starting July 30, 2001

5. For pumps older than July 2004, and for bearing isolator kit, see page 113.

11. Used on 213-U2 and 323-U2 only.

16. For seals, see page 102.

17. For vented covers, see page 114.

47. For shaft & bearing assembly part numbers, see page 112.

210, 213, 214, 320, 323, 324, 370-U2 Common Parts, cont'd

ITEM NO.	DESCRIPTION	QTY. PER PUMP	PART NO.	NOTES
29	Spacer, Gear to Rear Bearing	2	102474+	4
	Spacer, Gear to Rear Bearing		117691+	3
30	Bearing Spacer	2	102472+	
30A	Spacer Seal	2	102473+	
31	Retainer, Grease	2	STD091000	
32	Bearing Retainer, Front	2	123533+	5
	Bearing Retainer, Front, SS, used with bearing isolators		121141+	5
33A	3/8-16 x .75" HHCS	6	30-50	
33B	5/16-18 x 1" HHCS	8	30-34	
33C	3/8" Flat Washer	6	43-30	
34	Dowel Bushings	2	0H1116000	
36*	210-214-U2 O-Ring, Pump Cover, Buna N	1	N70382	
	210-214-U2 O-Ring, Pump Cover, EPDM	1	E70382	
	210-214-U2 O-Ring, Pump Cover, FKM	1	V70382	
	210-214-U2 O-Ring, Pump Cover, Silicone	1	S75382	
	320-324-370-U2 O-Ring, Pump Cover, Buna N	1	N70383	
	320-324-370-U2 O-Ring, Pump Cover, EPDM	1	E70383	
	320-324-370-U2 O-Ring, Pump Cover, FKM	1	V70383	
	320-324-370-U2 O-Ring, Pump Cover, Silicone	1	S75383	
	213-323-U2 O-Ring, Pump Cover, Outer, EPDM	1	323117012+	11
	213-323-U2 O-Ring, Pump Cover, Outer, Silicone	1	323117013+	11
36A*	213-323-U2 O-Ring, Pump Cover, Outer, FKM	1	323117014+	11
	213-323-U2 O-Ring, Pump Cover, Inner, EPDM	1	323117002+	11
	213-323-U2 O-Ring, Pump Cover, Inner, Silicone	1	323117003+	11
36B*	213-323-U2 O-Ring, Pump Cover, Inner, FKM	1	323117004+	11
	214-U2 Flange O-ring, Buna N	1	N70377	
	214-U2 Flange O-ring, EPDM	1	E70377	
	214-U2 Flange O-ring, FKM	1	V70377	
	324-U2 Flange O-ring, Buna N	1	N70378	
	324-U2 Flange O-ring, EPDM	1	E70378	
36C*	324-U2 Flange O-ring, FKM	1	V70378	
	O-Ring, Pump Jacketed Cover, Buna N	1	GD0117000	
	O-Ring, Pump Jacketed Cover, EPDM	1	GD0117002	
	O-Ring, Pump Jacketed Cover, FKM	1	GD0117V00	
37	O-Ring, Pump Jacketed Cover, Silicone	1	GD0117SC0	
	Stop Pin, Seal	6	102438+	
41	Locknut, Gear	2	105697+	
42	Gear Case Shim, CI	1	40288+	
	Pump Pedestal, 22", Optional	1	324110226+	
43	Plastic Cap Plug	8	000121001+	
44	1/2-13 x 1-3/4" HHCS	4	30-127X	
44A	Lock Washer, 1/2"	4	43-16	
45	210-213-214-U2 Body Retaining Screws - 3/8-16 x 3-1/2"	2	30-326	
	320-323-324-U2 Body Retaining Screws - 3/8-16 x 4-1/2"	2	30-323	
	370-U2 Body Retaining Screws - 3/8-16 x 6"	2	30-717	
46	Eye Bolt	3	30-360	
47	Key, Coupling - 5/8 x 5/8 x 2-3/4"	1	000037005+	
	Key, Coupling - Tru-Fit	1	119718+	

Notes: See page 96.

210, 213, 214, 320, 323, 324, 370-U2 Common Parts, cont'd

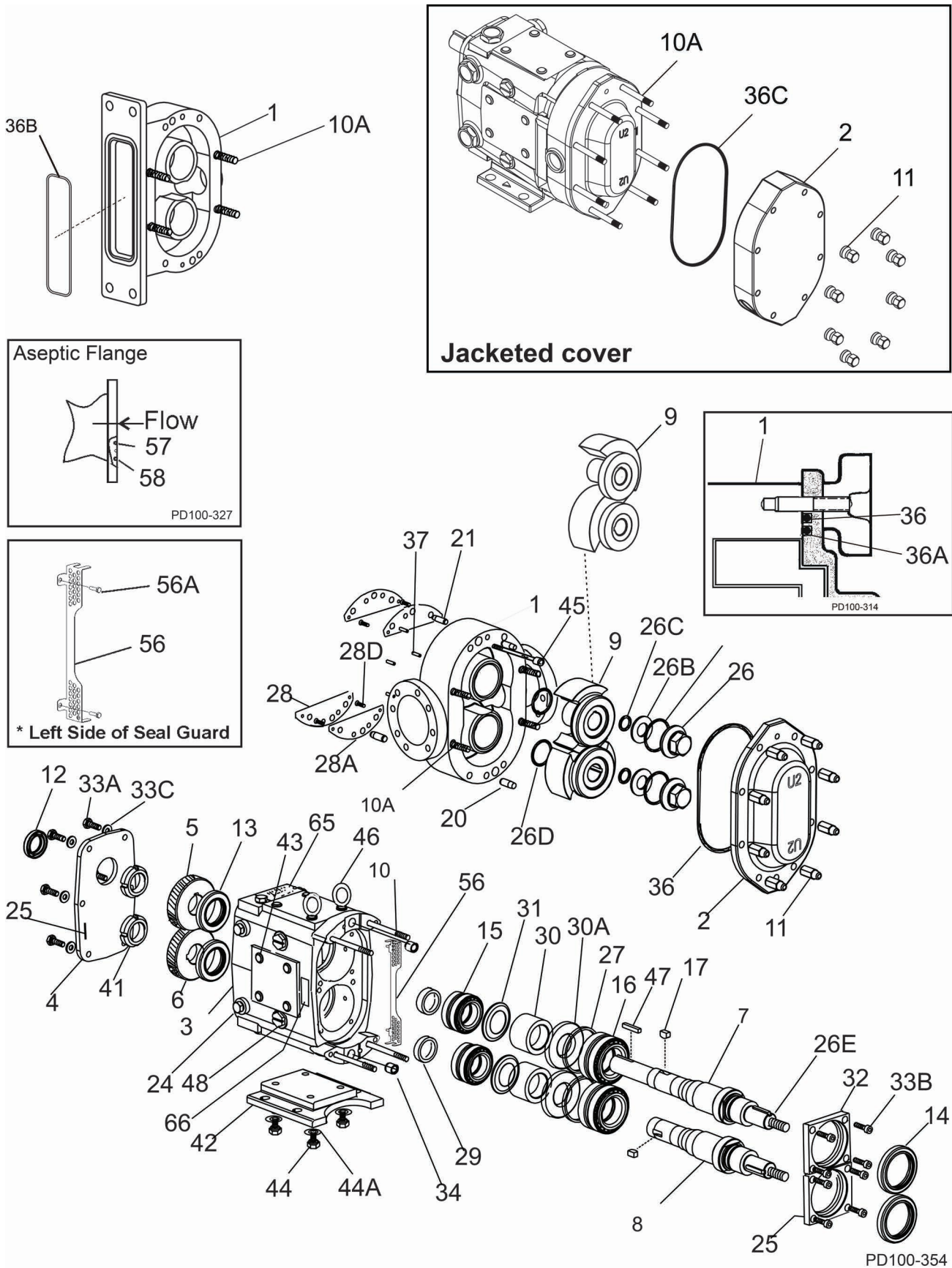

210, 213, 214, 320, 323, 324, 370-U2 Common Parts, cont'd

ITEM NO.	DESCRIPTION	QTY. PER PUMP	PART NO.	NOTES
48	Cleanout Plug	2	41013+	15
56	210-213-U2 Seal Guard	2	113503+	
	214-U2 Seal Guard	1	113503+	
		1	126361+	
	320-323-370-U2 Seal Guard	2	113504+	
	324-U2 Seal Guard	1	113504+	
1		126360+		
56A	1/4 - 20 x 3/8" HHCS	4	30-68	
60A	1/8-27 Aseptic Connection Pipe Plugs	10	STD128500	11
61	Name Plate, Sanitary	1	135624+	
62	#2 x .187" RHDS	4	30-355	
65	Caution Plate	2	121694+	
66	Warning Label	2	33-60	
67	Grease Fitting, 1/8"	4	BD0092000	1
68	Plastic Cap, Grease Fitting	4	BD0093000	

Notes:

1. This grease fitting is the straight style. Part number BD0092100 is the angled style.
11. Used on 213-U2 and 323-U2 only.
15. For an older gear case without a threaded plug hole, use plug p/n 000121001+

Aseptic Flange

ITEM NO.	DESCRIPTION	QTY. PER PUMP	PART NO.	NOTES
57	O-Ring, Port, Inner, EPDM	2	E70261	12
	O-Ring, Port, Inner, FKM		V70261	
	O-Ring, Port, Inner, Silicone		S75261	
58	O-Ring, Port, Outer, EPDM	2	E70265	12
	O-Ring, Port, Outer, FKM		V70265	
	O-Ring, Port, Outer, Silicone		S75265	

Notes:

- * Recommended spare parts
- 12. Used on 323-U2 only.
- 14. For 213-U2 pump part identification, please contact customer service and provide a serial number.

Universal 2 Standard Seals

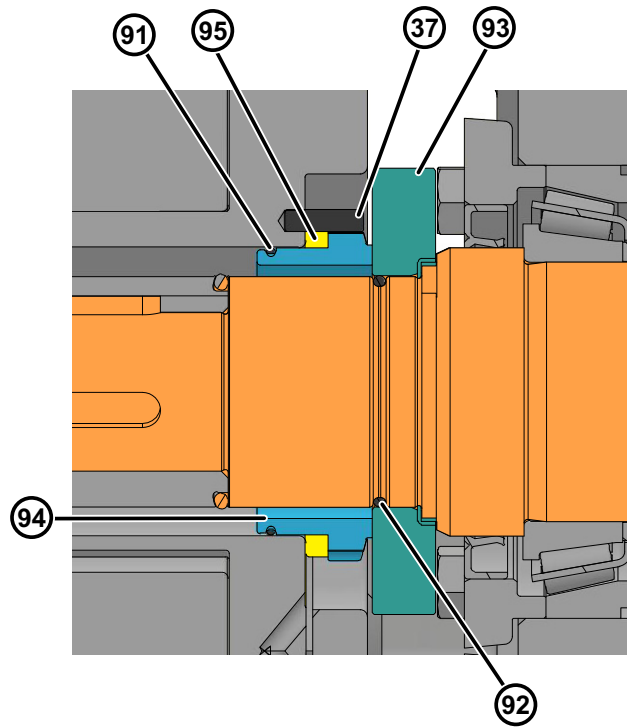

Figure 88 - Standard Single Mechanical Seal

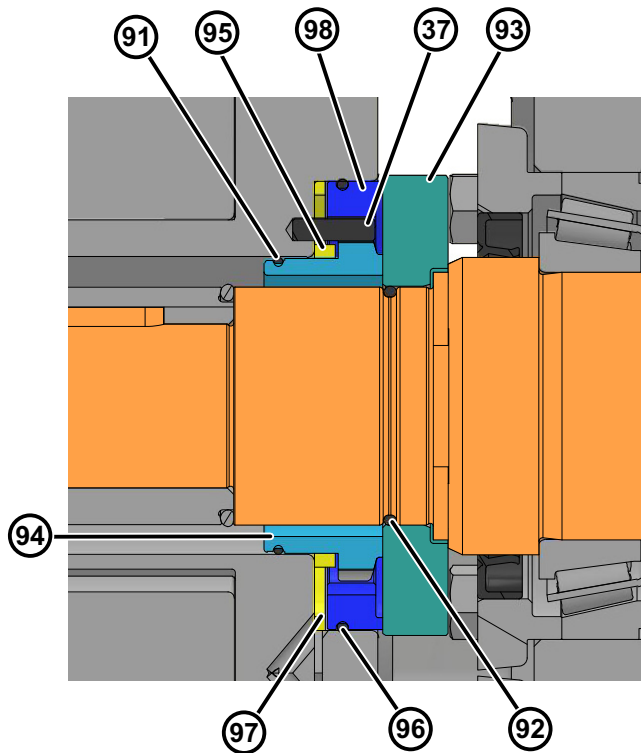

Figure 89 - Standard Double Mechanical Seal

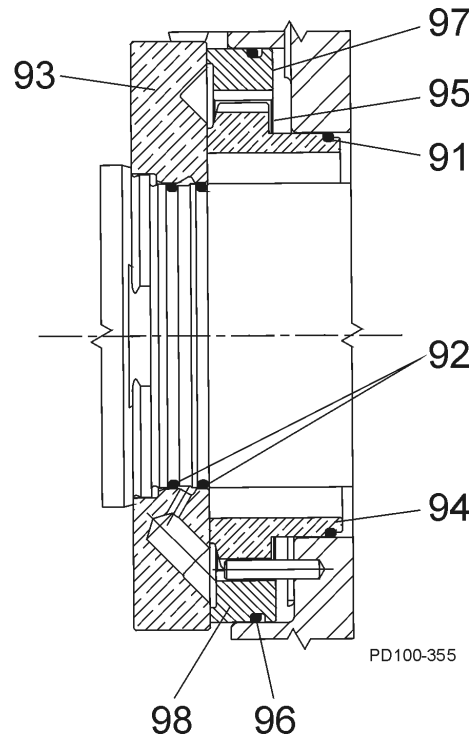

Figure 90 - Aseptic Design Double Mechanical Seal (213, 323 U2 ONLY)

Universal 2 Standard Seals

Item No.	Description	Part No. (by model)						Qty. per Pump			
		006, 014, 015, 018-U2	030, 034, 040 U2	045, 060, 064, 130, 134-U2	180, 220, 224 U2	210, 214, 320, 324, 370-U2	213, 323-U2	SM Seal	DM Seal	Aseptic U2-323) DM Seal	
* 91	O-Ring, Inner Seal	Buna N	N70028	N70031	N70035	N70041	N70154		2	2	2
		EPDM	E70028	E70031	E70035	E70041	E70154				
		FKM	V70028	V70031	V70035	V70041	V70154				
* 92	O-Ring, Shaft	Buna N	N70024	N70029	N70133	N70145	N70149		2	2	4
		EPDM	E70024	E70029	E70133	E70145	E70149				
		FKM	V70024	V70029	V70133	V70145	V70149				
* 93	Seat, Seal	CER	101667+	101670+	101673+	101676+	105416+	N/A	2	2	2
		SC	101668+	101671+	101674+	101677+	105417+	112192+			
		TC	119509+	119510+	119511+	119512+	119513+	N/A			
* 94	Seal, Inner	C	101651+	101655+	101659+	101663+	105412+		2	2	2
		CER	101652+	101656+	101660+	101664+	105413+				
		SC	101653+	101657+	101661+	101665+	105414+				
		TC	101654+	101658+	101662+	101666+	105415+				
95	Wave Spring, Inner Seal	101683+	101685+	101687+	101689+	105419+		2	2	2	
* 96	O-Ring, Outer Seal	Buna N	N70035	N70041	N70043	N70046	N70160		N/A	2	2
		EPDM	E70035	E70041	E70043	E70046	E70160				
		FKM	V70035	V70041	V70043	V70046	V70160				
97	Wave Spring, Outer Seal	101684+	101686+	101688+	101690+	105420+		N/A	2	2	
* 98	Outer Seal	C	101679+	101680+	101681+	101682+	105418+		N/A	2	2

PL5060-CH75b

Notes:

- * Recommended spare parts
- 6. See page 61 for O-ring selections, descriptions and color codes.

Abbreviation Key:

- SM Single Mechanical
- DM Double Mechanical
- C Carbon
- CER Ceramic
- SC Silicon Carbide
- TC Tungsten Carbide
- NF Narrow Face

Universal 2 Narrow Face (NF) Seals

The Universal 2 Narrow Face (NF) seal is available in the single or double mechanical seal design. The smaller diameter rotating seal seat (item 93) is only used with the SM NF seal.

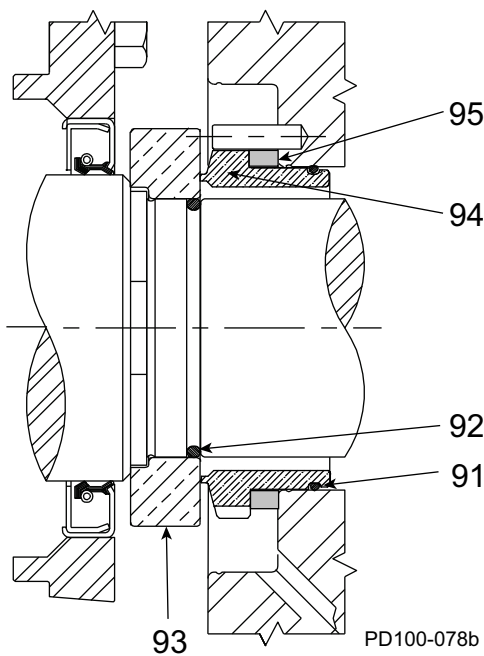

Figure 91 - NF Single Mechanical Seal

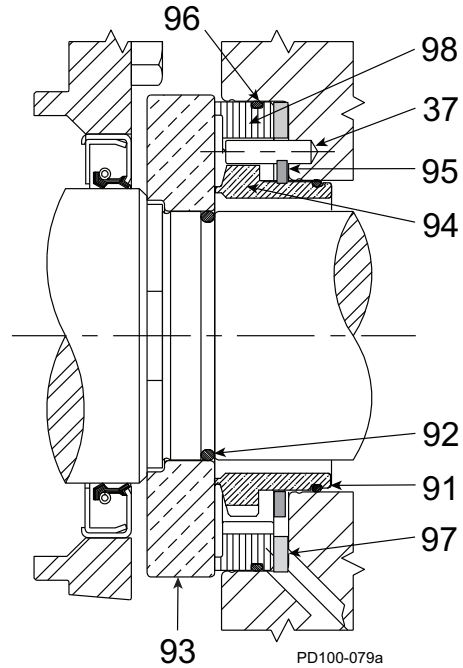

Figure 92 - NF Double Mechanical Seal

Item No.	Description	Part No. (by model)					Qty. per Pump,		
		006, 014, 015, 018 U2	030, 034, 040 U2	045, 060, 064, 130, 134 U2	180, 220, 224 U2	210, 214, 320, 324, 370 U2	SM	DM	
* 91	O-Ring, Inner Seal	Buna N	N70028	N70031	N70035	N70041	N70154	2	2
		EPDM	E70028	E70031	E70035	E70041	E70154		
		FKM	V70028	V70031	V70035	V70041	V70154		
* 92	O-Ring, Inner Shaft	Buna N	N70024	N70029	N70133	N70145	N70149	2	2
		EPDM	E70024	E70029	E70133	E70145	E70149		
		FKM	V70024	V70029	V70133	V70145	V70149		
* 93	SM NF Seal Seat	SC	124743+	124745+	124747+	124749+	124751+	2	N/A
		TC	124744+	124746+	124748+	124750+	124752+		
	DM NF Seal Seat	SC	101668+	101671+	101674+	101677+	105417+	N/A	2
		TC	119509+	119510+	119511+	119512+	119513+		
* 94	NF Seal, Inner	SC	124734+	124736+	124738+	124740+	124742+	2	2
		TC	124733+	124735+	124737+	124739+	124741+		
95	Wave Spring, Inner Seal	101683+	101685+	101687+	101689+	105419+	2	2	
* 96	O-Ring, Outer Seal	Buna N	N70035	N70041	N70043	N70046	N70160	N/A	2
		EPDM	E70035	E70041	E70043	E70046	E70160		
		FKM	V70035	V70041	V70043	V70046	V70160		
97	Wave Spring, Outer Seal	101684+	101686+	101688+	101690+	105420+	N/A	2	
* 98	Outer Seal	Carbon	101679+	101680+	101681+	101682+	105418+	N/A	2

PL5060-CH75a1

Notes:

- * Recommended spare parts
- 2. NF seals are NOT available on the 213-U2 or 323-U2.
- 6. See page 61 for O-ring selections, descriptions and color codes.

Abbreviation Key: SM Single Mechanical, DM Double Mechanical
 C Carbon, CER Ceramic, SC Silicon Carbide, TC Tungsten Carbide, NF Narrow Face

Universal 2 High-Pressure Barrier (HPB) Seals

To calculate the barrier pressure, see “Universal 2 High-Pressure Barrier (HPB) Seals” on page 23.

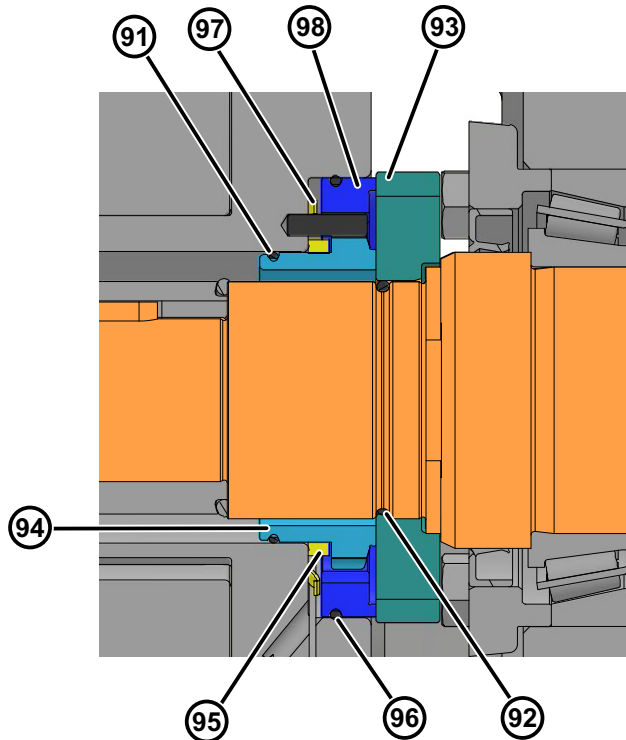

Figure 93 - High Pressure Barrier (HPB) Seal

Item No.	Description	Part No. (by model)					Qty. per Pump, HPB Seal	
		006, 014, 015, 018 U2	030, 034, 040 U2	045, 060, 064, 130, 134 U2	180, 220, 224 U2	210, 214, 320, 324, 370 U2		
* 91	O-Ring, Inner Seal	Buna N	N70028	N70031	N70035	N70041	N70154	2
		EPDM	E70028	E70031	E70035	E70041	E70154	
		FKM	V70028	V70031	V70035	V70041	V70154	
* 92	O-Ring, Inner Shaft	Buna N	N70024	N70029	N70133	N70145	N70149	2
		EPDM	E70024	E70029	E70133	E70145	E70149	
		FKM	V70024	V70029	V70133	V70145	V70149	
* 93	HPB Seal Seat	CER	101667+	101670+	101673+	101676+	105416+	2
		SC	101668+	101671+	101674+	101677+	105417+	
* 94	HPB Seal, Inner	SC	110821+	110823+	110825+	110827+	110829+	2
		TC	122324+	122325+	122326+	122327+	122328+	
95	Wave Spring, Inner Seal		101683+	101685+	101687+	101689+	105419+	2
* 96	O-Ring, Outer Seal	Buna N	N70035	N70041	N70043	N70046	N70160	2
		EPDM	E70035	E70041	E70043	E70046	E70160	
		FKM	V70035	V70041	V70043	V70046	V70160	
97	Wave Spring, Outer Seal		101684+	101686+	101688+	101690+	105420+	2
* 98	Outer Seal	Carbon	101679+	101680+	101681+	101682+	105418+	2

PL5060-CH75a2

Notes:

- * Recommended spare parts
- 2. HPB seals are NOT available on the 213-U2 or 323-U2.
- 6. See page 61 for O-ring selections, descriptions and color codes.

Abbreviation Key: SM Single Mechanical, DM Double Mechanical
 C Carbon, CER Ceramic, SC Silicon Carbide, TC Tungsten Carbide, HPB High-Pressure Barrier

Triple Lip Seal

Triple Lip Seal components

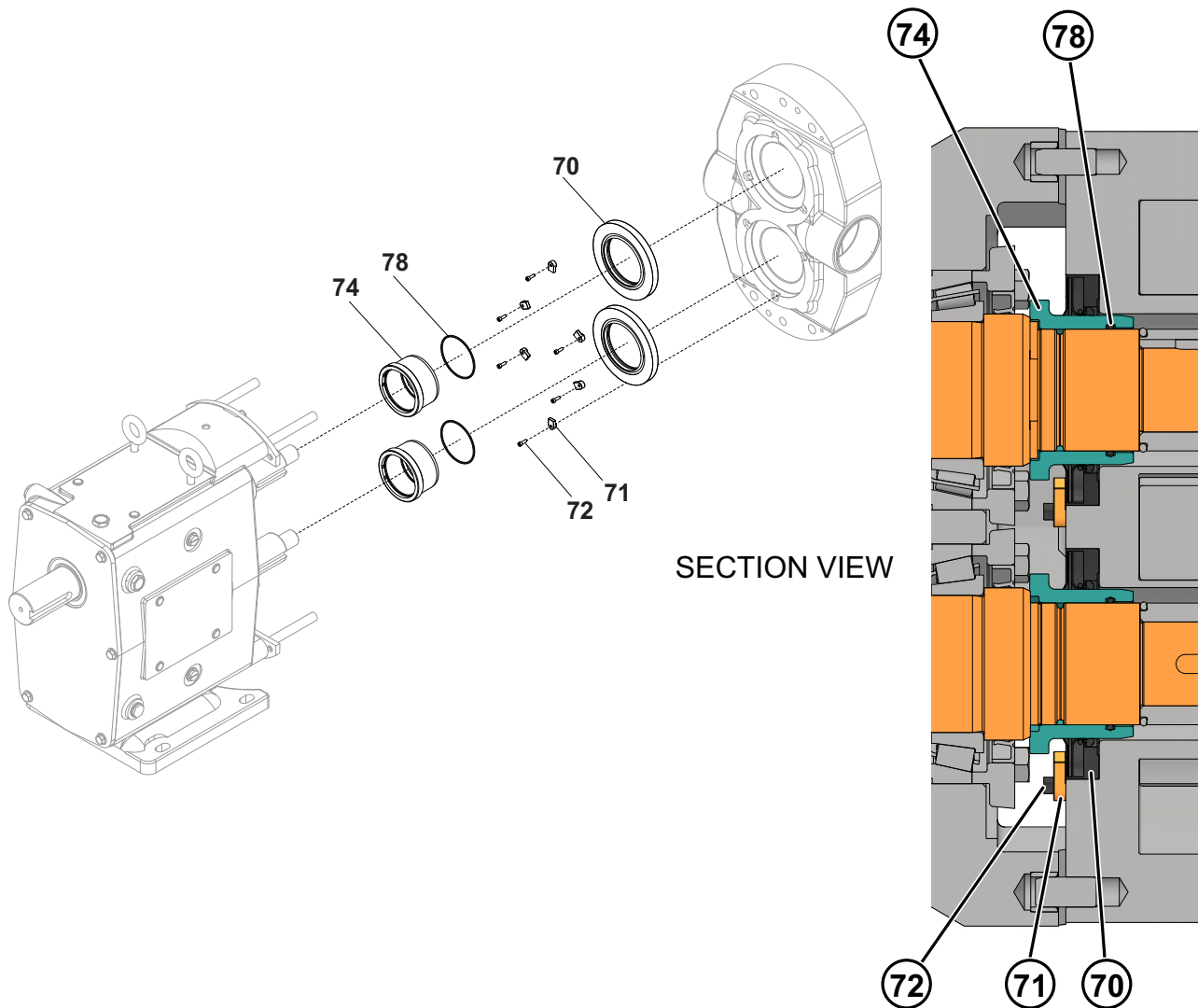

Triple Lip Seal components

ITEM NO.	DESCRIPTION	QTY PER PUMP	PART NO. 006-015-018	PART NO. 030-040	PART NO. 045-060-130	PART NO. 180-220	PART NO. 210-320-370	NOTES
70	Lip Seal	2	308787+	310098+	310918+	310338+	310341+	
71	Retainer-Tab	4	308788+	308788+	308788+	308788+ (6)	308788+ (6)	1
72	Retainer-Tab bolt	4	137460+	137460+	137460+	137460+ (6)	137460+ (6)	1
74	Sleeve, SiC	2	308774+	310099+	310920+	310336+	310339+	
	Sleeve, SS 316L	2	308775+	310100+	310921+	310337+	310340+	
78*	O-ring, Sleeve-Buna	2	N70026	N70030	N70136	N70148	N70151	
	O-ring, Sleeve-EPDM	2	E70026	E70030	E70136	E70148	V70151	
	O-ring, Sleeve-FKM	2	V70026	V70030	V70136	V70148	E70151	
	O-ring, Sleeve-FFKM	2	K70026	K70030	K70136	K70148	K70151	

NOTE:

*** Recommended Spare Parts**

1. For pump size 180-370, there are 3 Qty of Retainer-Tabs and 3 Qty of Retainer-Tabs Bolts for per lip seal.

Seal Kits - 006, 015, 018-U2, 014-U2, 030, 040-U2, 034-U2

Description	Kit Part#	Description	Kit Part#
SEAL KIT, 015U2, SM, C/CE, BUNA	131420+	SEAL KIT, 030U2, SM, C/CE, BUNA	129648+
SEAL KIT, 015U2, SM, C/SC, BUNA	133247+	SEAL KIT, 030U2, SM, C/SC, BUNA	134300+
SEAL KIT, 015U2, SM, SC/SC, BUNA	133357+	SEAL KIT, 030U2, SM, SC/SC, BUNA	133362+
SEAL KIT, 015U2, SM, TC/SC, BUNA	133496+	SEAL KIT, 030U2, SM, TC/SC, BUNA	133501+
SEAL KIT, 015U2, SM, TC/SC, EPDM	133497+	SEAL KIT, 030U2, SM, C/CE, EPDM	133168+
SEAL KIT, 015U2, SM, C/CE, EPDM	133164+	SEAL KIT, 030U2, SM, C/SC, EPDM	134302+
SEAL KIT, 015U2, SM, C/SC, EPDM	133249+	SEAL KIT, 030U2, SM, SC/SC, EPDM	133363+
SEAL KIT, 015U2, SM, SC/SC, EPDM	133358+	SEAL KIT, 030U2, SM, TC/SC, EPDM	133503+
SEAL KIT, 015U2, SM, C/CE, FKM	133163+	SEAL KIT, 030U2, SM, C/CE, FKM	123985+
SEAL KIT, 015U2, SM, C/SC, FKM	133248+	SEAL KIT, 030U2, SM, C/SC, FKM	134301+
SEAL KIT, 015U2, SM, SC/SC, FKM	126889+	SEAL KIT, 030U2, SM, SC/SC, FKM	125019+
SEAL KIT, 015U2, SM, TC/SC, FKM	125945+	SEAL KIT, 030U2, SM, TC/SC, FKM	133502+
SEAL KIT, 015U2, SM, TC/SC NF, FKM	137232+	SEAL KIT, 030U2, DM, SC/SC-C/SC, BUNA	133905+
SEAL KIT, 015U2, DM, C/CE-C/CE, BUNA	133820+	SEAL KIT, 030U2, DM, SC/SC-C/SC NF, BUNA	133962+
SEAL KIT, 015U2, DM, SC/SC-C/SC, BUNA	133900+	SEAL KIT, 030U2, DM, TC/SC-C/SC NF, BUNA	134025+
SEAL KIT, 015U2, DM, SC/SC-C/SC NF, BUNA	133956+	SEAL KIT, 030U2, DM, C/CE-C/CE, BUNA	133825+
SEAL KIT, 015U2, DM, SC/C-C/SC NF, BUNA	122956+	SEAL KIT, 030U2, DM, SC/SC-C/SC, EPDM	133906+
SEAL KIT, 015U2, DM, TC/SC-C/SC NF, BUNA	134019+	SEAL KIT, 030U2, DM, SC/SC-C/SC NF, EPDM	133964+
SEAL KIT, 015U2, DM, C/CE-C/CE, EPDM	133821+	SEAL KIT, 030U2, DM, TC/SC-C/SC NF, EPDM	134027+
SEAL KIT, 015U2, DM, SC/SC-C/SC, EPDM	133901+	SEAL KIT, 030U2, DM, C/CE-C/CE, EPDM	133826+
SEAL KIT, 015U2, DM, SC/SC-C/SC NF, EPDM	133958+	SEAL KIT, 030U2, DM, C/CE-C/CE, FKM	123986+
SEAL KIT, 015U2, DM, TC/SC-C/SC NF, EPDM	134021+	SEAL KIT, 030U2, DM, SC/SC-C/SC NF, FKM	133963+
SEAL KIT, 015U2, DM, SC/SC-C/SC NF, FKM	133957+	SEAL KIT, 030U2, DM, TC/SC-C/SC NF, FKM	134026+
SEAL KIT, 015U2, DM, TC/SC-C/SC NF, FKM	134020+	SEAL KIT, 030U2, DM, SC/SC-C/SC, FKM	130841+
SEAL KIT, 015U2, DM, C/CE, FKM	130840+	SEAL KIT, 030U2, DM, TC/SC-C/SC, FKM	137907+
SEAL KIT, 015U2, DM, SC/SC-C/SC, FKM	130847+	SEAL KIT, 034U2, SM, C/CE, BUNA	133169+
SEAL KIT, 015U2, DM, TC/SC-C/SC, FKM	137908+	SEAL KIT, 034U2, SM, C/SC, BUNA	134303+
SEAL KIT, 014U2, SM, C/CE, BUNA	133165+	SEAL KIT, 034U2, SM, SC/SC, BUNA	134294+
SEAL KIT, 014U2, SM, C/SC, BUNA	133250+	SEAL KIT, 034U2, SM, TC/SC, BUNA	133504+
SEAL KIT, 014U2, SM, C/SC, BUNA	134297+	SEAL KIT, 034U2, SM, C/CE, FKM	133170+
SEAL KIT, 014U2, SM, SC/SC, BUNA	133359+	SEAL KIT, 034U2, SM, C/SC, FKM	134304+
SEAL KIT, 014U2, SM, TC/SC, BUNA	133498+	SEAL KIT, 034U2, SM, SC/SC, FKM	134295+
SEAL KIT, 014U2, SM, C/CE, FKM	133166+	SEAL KIT, 034U2, SM, TC/SC, FKM	133505+
SEAL KIT, 014U2, SM, C/SC, FKM	133255+	SEAL KIT, 034U2, DM, C/CE-C/CE, BUNA	133827+
SEAL KIT, 014U2, SM, C/SC, FKM	134298+	SEAL KIT, 034U2, DM, SC/SC-C/SC, BUNA	133907+
SEAL KIT, 014U2, SM, SC/SC, FKM	133360+	SEAL KIT, 034U2, DM, SC/SC-C/SC NF, BUNA	133965+
SEAL KIT, 014U2, SM, TC/SC, FKM	133499+	SEAL KIT, 034U2, DM, TC/SC-C/SC NF, BUNA	134028+
SEAL KIT, 014U2, DM, C/CE-C/CE, BUNA	133822+	SEAL KIT, 034U2, DM, C/CE-C/CE, EPDM	133829+
SEAL KIT, 014U2, DM, SC/SC-C/SC, BUNA	133902+	SEAL KIT, 034U2, DM, SC/SC-C/SC, EPDM	133909+
SEAL KIT, 014U2, DM, SC/SC-C/SC NF, BUNA	133959+	SEAL KIT, 034U2, DM, SC/SC-C/SC NF, EPDM	133967+
SEAL KIT, 014U2, DM, TC/SC-C/SC NF, BUNA	134022+	SEAL KIT, 034U2, DM, TC/SC-C/SC NF, EPDM	134030+
SEAL KIT, 014U2, DM, C/CE-C/CE, EPDM	133824+	SEAL KIT, 034U2, DM, C/CE-C/CE, FKM	133828+
SEAL KIT, 014U2, DM, SC/SC-C/SC, EPDM	133904+	SEAL KIT, 034U2, DM, SC/SC-C/SC, FKM	133908+
SEAL KIT, 014U2, DM, SC/SC-C/SC NF, EPDM	133961+	SEAL KIT, 034U2, DM, SCNF/SC-C/SC, FKM	133966+
SEAL KIT, 014U2, DM, TC/SC-C/SC NF, EPDM	134024+	SEAL KIT, 034U2, DM, TCNF/SC-C/SC, FKM	134029+
SEAL KIT, 014U2, DM, C/CE-C/CE, FKM	133823+	SEAL KIT, 034U2, SM, C/CE, EPDM	133171+
SEAL KIT, 014U2, DM, SC/SC-C/SC, FKM	133903+	SEAL KIT, 034U2, SM, C/SC, EPDM	134305+
SEAL KIT, 014U2, DM, SCF/SC-C/SC NF, FKM	133960+	SEAL KIT, 034U2, SM, SC/SC, EPDM	134296+
SEAL KIT, 014U2, DM, TC/SC-C/SC NF, FKM	134023+	SEAL KIT, 034U2, SM, TC/SC, EPDM	133506+
SEAL KIT, 014U2, SM, C/CE, EPDM	133167+		
SEAL KIT, 014U2, SM, C/SC, EPDM	133256+		
SEAL KIT, 014U2, SM, SC/SC, EPDM	133361+		
SEAL KIT, 014U2, SM, TC/SC, EPDM	133500+		

Notes: 015U2 kits apply to 006, 015, 018-U2;

030U2 kits apply to 030 and 040-U2

Abbreviation Key: SM Single Mechanical;

DM Double Mechanical; C Carbon; SC Silicon Carbide

TC Tungsten Carbide; NF Narrow Face

Seal Kits - 045, 060, 130-U2, 180, 220-U2

Description	Kit Part#
SEAL KIT, 060U2, SM, C/CE, BUNA	131422+
SEAL KIT, 060U2, SM, C/SC, BUNA	133257+
SEAL KIT, 060U2, SM, SC/SC, BUNA	133364+
SEAL KIT, 060U2, SM, TC/SC, BUNA	133507+
SEAL KIT, 060U2, SM, C/CE, EPDM	133172+
SEAL KIT, 060U2, SM, C/CE, EPDM	133178+
SEAL KIT, 060U2, SM, C/SC, EPDM	133258+
SEAL KIT, 060U2, SM, SC/SC, EPDM	133365+
SEAL KIT, 060U2, SM, TC/SC, EPDM	133508+
SEAL KIT, 060U2, SM, C/CE, FKM	126890+
SEAL KIT, 060U2, SM, C/SC, FKM	128193+
SEAL KIT, 060U2, SM, SC/SC, FKM	125020+
SEAL KIT, 060U2, SM, TC/SC, FKM	125023+
SEAL KIT, 060U2, DM, C/CE-C/CE, BUNA	133830+
SEAL KIT, 060U2, DM, SC/SC-C/SC, BUNA	133910+
SEAL KIT, 060U2, DM, SC/SC-C/SC NF, BUNA	133968+
SEAL KIT, 060U2, DM, TC/SC-C/SC NF, BUNA	134031+
SEAL KIT, 060U2, DM, C/CE-C/CE, EPDM	133832+
SEAL KIT, 060U2, DM, SC/SC-C/SC, EPDM	133912+
SEAL KIT, 060U2, DM, SC/SC-C/SC NF, EPDM	133970+
SEAL KIT, 060U2, DM, TC/SC-C/SC NF, EPDM	134033+
SEAL KIT, 060U2, DM, C/CE-C/CE, FKM	133831+
SEAL KIT, 060U2, DM, SC/SC-C/SC, FKM	128040+
SEAL KIT, 060U2, DM, SCNF/SC-C/SC, FKM	133969+
SEAL KIT, 060U2, DM, TC/SC-C/SC, FKM	136951+
SEAL KIT, 060U2, DM, TC/SC-C/SC NF, FKM	134032+
SEAL KIT, 060U2, DM, TC/TC-C/TC NF, FKM	135752+
SEAL KIT, 064U2, SM, C/CE, BUNA	133173+
SEAL KIT, 064U2, SM, C/SC, BUNA	134306+
SEAL KIT, 064U2, SM, SC/SC, BUNA	134099+
SEAL KIT, 064U2, SM, TC/SC, BUNA	133512+
SEAL KIT, 064U2, SM, C/CE, FKM	133174+
SEAL KIT, 064U2, SM, C/SC, FKM	134307+
SEAL KIT, 064U2, SM, SC/SC, FKM	134100+
SEAL KIT, 064U2, SM, TC/SC, FKM	133513+
SEAL KIT, 064U2, DM, C/CE-C/CE, BUNA	133836+
SEAL KIT, 064U2, DM, SC/SC-C/SC, BUNA	133916+
SEAL KIT, 064U2, DM, SC/SC-C/SC NF, BUNA	133974+
SEAL KIT, 064U2, DM, TC/SC-C/SC NF, BUNA	134037+
SEAL KIT, 064U2, DM, C/CE-C/CE, EPDM	133838+
SEAL KIT, 064U2, DM, SC/SC-C/SC, EPDM	133918+
SEAL KIT, 064U2, DM, SC/SC-C/SC NF, EPDM	133976+
SEAL KIT, 064U2, DM, TC/SC-C/SC NF, EPDM	134039+
SEAL KIT, 064U2, DM, C/CE-C/CE, FKM	133837+
SEAL KIT, 064U2, DM, SC/SC-C/SC, FKM	133917+
SEAL KIT, 064U2, DM, SC/SC-C/SC NF, FKM	133975+
SEAL KIT, 064U2, DM, TC/SC-C/SC NF, FKM	134038+
SEAL KIT, 064U2, SM, C/CE, EPDM	133175+
SEAL KIT, 064U2, SM, C/SC, EPDM	134308+
SEAL KIT, 064U2, SM, SC/SC, EPDM	134101+
SEAL KIT, 064U2, SM, TC/SC, EPDM	133514+

Notes: 045U2 kits apply to 045, 060, 130-U2;
220U2 kits apply to 180 and 220-U2

Description	Kit Part#
SEAL KIT, 134U2, SM, C/CE, BUNA	133179+
SEAL KIT, 134U2, SM, C/SC, BUNA	134309+
SEAL KIT, 134U2, SM, SC/SC, BUNA	134105+
SEAL KIT, 134U2, SM, TC/SC, BUNA	133518+
SEAL KIT, 134U2, SM, C/CE, FKM	133180+
SEAL KIT, 134U2, SM, C/SC, FKM	134310+
SEAL KIT, 134U2, SM, SC/SC, FKM	134106+
SEAL KIT, 134U2, SM, TC/SC, FKM	133519+
SEAL KIT, 134U2, DM, C/CE-C/CE, BUNA	133839+
SEAL KIT, 134U2, DM, SC/SC-C/SC, BUNA	133922+
SEAL KIT, 134U2, DM, SC/SC-C/SC NF, BUNA	133980+
SEAL KIT, 134U2, DM, TC/SC-C/SC NF, BUNA	134043+
SEAL KIT, 134U2, DM, C/CE-C/CE, EPDM	133841+
SEAL KIT, 134U2, DM, SC/SC-C/SC, EPDM	133924+
SEAL KIT, 134U2, DM, SC/SC-C/SC NF, EPDM	133982+
SEAL KIT, 134U2, DM, TC/SC-C/SC NF, EPDM	134045+
SEAL KIT, 134U2, DM, C/CE-C/CE, FKM	133840+
SEAL KIT, 134U2, DM, SC/SC-C/SC, FKM	133923+
SEAL KIT, 134U2, DM, SCF/SC-C/SC NF, FKM	133981+
SEAL KIT, 134U2, DM, TC/SC-C/SC NF, FKM	134044+
SEAL KIT, 134U2, SM, C/CE, EPDM	133181+
SEAL KIT, 134U2, SM, C/SC, EPDM	134311+
SEAL KIT, 134U2, SM, SC/SC, EPDM	134107+
SEAL KIT, 134U2, SM, TC/SC, EPDM	133520+
SEAL KIT, 220U2, SM, C/CE, BUNA	131423+
SEAL KIT, 220U2, SM, C/SC, BUNA	134318+
SEAL KIT, 220U2, SM, TC/SC, BUNA	133530+
SEAL KIT, 220U2, SM, C/CE, FKM	133196+
SEAL KIT, 220U2, SM, C/SC, FKM	134319+
SEAL KIT, 220U2, SM, SC/SC, FKM	125021+
SEAL KIT, 220U2, SM, TC/SC, FKM	125024+
SEAL KIT, 220U2, SM, TC/TC, FKM	136745+
SEAL KIT, 220U2, SM, SC/SC, BUNA	133368+
SEAL KIT, 220U2, DM, C/CE-C/CE, BUNA	133848+
SEAL KIT, 220U2, DM, SC/SC-C/SC, BUNA	133928+
SEAL KIT, 220U2, DM, SC/SC-C/SC NF, BUNA	133989+
SEAL KIT, 220U2, DM, TC/SC-C/SC NF, BUNA	134049+
SEAL KIT, 220U2, DM, C/CE-C/CE, EPDM	133850+
SEAL KIT, 220U2, DM, SC/SC-C/SC, EPDM	133929+
SEAL KIT, 220U2, DM, SC/SC-C/SC NF, EPDM	133991+
SEAL KIT, 220U2, DM, TC/SC-C/SC NF, EPDM	134071+
SEAL KIT, 220U2, DM, C/CE-C/CE, FKM	133849+
SEAL KIT, 220U2, DM, SC/SC-C/SC, FKM	129647+
SEAL KIT, 220U2, DM, SC/SC-C/SC NF, FKM	133990+
SEAL KIT, 220U2, DM, TC/SC-C/SC NF, FKM	134050+
SEAL KIT, 220U2, SM, C/CE, EPDM	133197+
SEAL KIT, 220U2, SM, C/SC, EPDM	134320+
SEAL KIT, 220U2, SM, TC/SC, EPDM	133531+
SEAL KIT, 220U2, SM, SC/SC, EPDM	133369+

Abbreviation Key: SM Single Mechanical;
DM Double Mechanical; C Carbon; SC Silicon Carbide
TC Tungsten Carbide; NF Narrow Face

Seal Kits - 184-U2, 210, 213-U2, 214-U2, 224-U2

Description	Kit Part#	Description	Kit Part#
SEAL KIT, 184U2, DM, SC/SC-C/SC, EPDM	133935+	SEAL KIT, 214U2, SM, C/CE, BUNA	133215+
SEAL KIT, 184U2, DM, C/CE-C/CE, FKM	133855+	SEAL KIT, 214U2, SM, C/SC, BUNA	134564+
SEAL KIT, 184U2, SM, C/CE, BUNA	133201+	SEAL KIT, 214U2, SM, SC/SC, BUNA	133552+
SEAL KIT, 184U2, SM, C/SC, BUNA	134549+	SEAL KIT, 214U2, SM, C/CE, FKM	133216+
SEAL KIT, 184U2, SM, SC/SC, BUNA	134111+	SEAL KIT, 214U2, SM, C/SC, FKM	134565+
SEAL KIT, 184U2, SM, TC/SC, BUNA	133535+	SEAL KIT, 214U2, SM, SC/SC, FKM	134124+
SEAL KIT, 184U2, SM, C/CE, FKM	133202+	SEAL KIT, 214U2, SM, SC/SC, FKM	134124+
SEAL KIT, 184U2, SM, C/SC, FKM	134550+	SEAL KIT, 214U2, DM, C/CE-C/CE, BUNA	133872+
SEAL KIT, 184U2, SM, SC/SC, FKM	134112+	SEAL KIT, 214U2, DM, SC/SC-C/SC, BUNA	133950+
SEAL KIT, 184U2, SM, TC/SC, FKM	133536+	SEAL KIT, 214U2, DM, SC/SC-C/SC NF, BUNA	134013+
SEAL KIT, 184U2, DM, C/CE-C/CE, BUNA	133854+	SEAL KIT, 214U2, DM, TC/SC-C/SC NF, BUNA	134093+
SEAL KIT, 184U2, DM, SC/SC-C/SC, BUNA	133933+	SEAL KIT, 214U2, DM, C/CE-C/CE, EPDM	133874+
SEAL KIT, 184U2, DM, SC/SC-C/SC NF, BUNA	133995+	SEAL KIT, 214U2, DM, SC/SC-C/SC, EPDM	133952+
SEAL KIT, 184U2, DM, TC/SC-C/SC NF, BUNA	134075+	SEAL KIT, 214U2, DM, SC/SC-C/SC, EPDM	134015+
SEAL KIT, 184U2, DM, C/CE-C/CE, EPDM	133856+	SEAL KIT, 214U2, DM, TC/SC-C/SC NF, EPDM	134095+
SEAL KIT, 184U2, DM, SC/SC-C/SC NF, EPDM	133997+	SEAL KIT, 214U2, DM, SC/SC-C/SC, FKM	133951+
SEAL KIT, 184U2, DM, TC/SC-C/SC NF, EPDM	134077+	SEAL KIT, 214U2, DM, TC/SC-C/SC NF, FKM	134094+
SEAL KIT, 184U2, DM, SC/SC-C/SC, FKM	133934+	SEAL KIT, 214U2, SM, C/CE, EPDM	133217+
SEAL KIT, 184U2, DM, SC/SC-C/SC NF, FKM	133996+	SEAL KIT, 214U2, SM, C/SC, EPDM	134566+
SEAL KIT, 184U2, DM, TC/SC-C/SC NF, FKM	134076+	SEAL KIT, 214U2, SM, SC/SC, EPDM	133554+
SEAL KIT, 184U2, SM, C/CE, EPDM	133203+	SEAL KIT, 224U2, SM, C/CE, BUNA	133207+
SEAL KIT, 184U2, SM, C/SC, EPDM	134551+	SEAL KIT, 224U2, SM, C/SC, BUNA	134555+
SEAL KIT, 184U2, SM, SC/SC, EPDM	134113+	SEAL KIT, 224U2, SM, SC/SC, BUNA	134117+
SEAL KIT, 184U2, SM, TC/SC, EPDM	133537+	SEAL KIT, 224U2, SM, TC/SC, BUNA	133541+
SEAL KIT, 210U2, SM, C/CE, BUNA	131424+	SEAL KIT, 224U2, SM, C/C, EPDM	133209+
SEAL KIT, 210U2, SM, C/SC, BUNA	134561+	SEAL KIT, 224U2, SM, C/SC, EPDM	134557+
SEAL KIT, 210U2, SM, SC/SC, BUNA	133547+	SEAL KIT, 224U2, SM, SC/SC, EPDM	134119+
SEAL KIT, 210U2, SM, C/CE, FKM	133213+	SEAL KIT, 224U2, SM, TC/SC, EPDM	133543+
SEAL KIT, 210U2, SM, C/SC, FKM	134562+	SEAL KIT, 224U2, SM, C/CE, FKM	133208+
SEAL KIT, 210U2, SM, SC/SC, FKM	125022+	SEAL KIT, 224U2, SM, C/SC, FKM	134556+
SEAL KIT, 210U2, DM, C/CE-C/CE, BUNA	133866+	SEAL KIT, 224U2, SM, SC/SC, FKM	134118+
SEAL KIT, 210U2, DM, SC/SC-C/SC, BUNA	133945+	SEAL KIT, 224U2, SM, TC/SC, FKM	133542+
SEAL KIT, 210U2, DM, SC/SC-C/SC NF, BUNA	134007+	SEAL KIT, 224U2, DM, C/CE-C/CE, BUNA	133860+
SEAL KIT, 210U2, DM, TC/SC-C/SC NF, BUNA	134087+	SEAL KIT, 224U2, DM, SC/SC-C/SC, BUNA	133939+
SEAL KIT, 210U2, DM, C/CE-C/CE, EPDM	133868+	SEAL KIT, 224U2, DM, SC/SC-C/SC NF, BUNA	134001+
SEAL KIT, 210U2, DM, SC/SC-C/SC, EPDM	133946+	SEAL KIT, 224U2, DM, TC/SC-C/SC NF, BUNA	134081+
SEAL KIT, 210U2, DM, SC/SC-C/SC NF, EPDM	134009+	SEAL KIT, 224U2, DM, C/CE-C/CE, EPDM	133862+
SEAL KIT, 210U2, DM, TC/SC-C/SC NF, EPDM	134089+	SEAL KIT, 224U2, DM, SC/SC-C/SC, EPDM	133941+
SEAL KIT, 210U2, DM, C/CE-C/CE, FKM	133867+	SEAL KIT, 224U2, DM, SC/SC-C/SC NF, EPDM	134003+
SEAL KIT, 210U2, DM, SC/SC-C/SC, FKM	129787+	SEAL KIT, 224U2, DM, TC/SC-C/SC NF, EPDM	134083+
SEAL KIT, 210U2, DM, SC/SC-C/SC NF, FKM	134008+	SEAL KIT, 224U2, DM, C/CE-C/CE, FKM	133861+
SEAL KIT, 210U2, DM, TC/SC-C/SC NF, FKM	134088+	SEAL KIT, 224U2, DM, SC/SC-C/SC, FKM	133940+
SEAL KIT, 210U2, SM, C/CE, EPDM	133214+	SEAL KIT, 224U2, DM, SC/SC-C/SC, FKM	133943+
SEAL KIT, 210U2, SM, C/SC, EPDM	134563+	SEAL KIT, 224U2, DM, SC/SC-C/SC NF, FKM	134002+
SEAL KIT, 210U2, SM, SC/SC, EPDM	133548+	SEAL KIT, 224U2, DM, TC/SC-C/SC NF, FKM	134082+

Notes:

210U2 kits apply to 210-, 213-U2.

See "Notes:" on page 109.

Abbreviation Key:

SM Single Mechanical
DM Double Mechanical
C Carbon
SC Silicon Carbide
TC Tungsten Carbide
NF Narrow Face

Seal Kits - 320-U2, 370-U2, 324-U2

Description	Kit Part#	Description	Kit Part#
SEAL KIT, 320U2, SM, C/CE, BUNA	133218+	SEAL KIT, 324U2, SM, C/CE, BUNA	133221+
SEAL KIT, 320U2, SM, C/SC, BUNA	134567+	SEAL KIT, 324U2, SM, C/SC, BUNA	134570+
SEAL KIT, 320U2, SM, SC/SC, BUNA	133376+	SEAL KIT, 324U2, SM, SC/SC, BUNA	134126+
SEAL KIT, 320U2, SM, SC/SC, BUNA	133549+	SEAL KIT, 324U2, SM, C/CE, FKM	133222+
SEAL KIT, 320U2, SM, C/CE, FKM	133219+	SEAL KIT, 324U2, SM, C/SC, FKM	134571+
SEAL KIT, 320U2, SM, C/SC, FKM	134568+	SEAL KIT, 324U2, SM, SC/SC, FKM	133556+
SEAL KIT, 320U2, SM, SC/SC, FKM	133377+	SEAL KIT, 324U2, DM, C/CE-C/CE, BUNA	133875+
SEAL KIT, 320U2, SM, SC/SC, FKM	133550+	SEAL KIT, 324U2, DM, SC/SC-C/SC, BUNA	133953+
SEAL KIT, 320U2, DM, C/CE-C/CE, BUNA	133869+	SEAL KIT, 324U2, DM, SC/SC-C/SC NF, BUNA	134016+
SEAL KIT, 320U2, DM, SC/SC-C/SC, BUNA	133947+	SEAL KIT, 324U2, DM, TC/SC-C/SC NF, BUNA	134096+
SEAL KIT, 320U2, DM, SC/SC-C/SC NF, BUNA	134010+	SEAL KIT, 324U2, DM, C/CE-C/CE, EPDM	133877+
SEAL KIT, 320U2, DM, TC/SC-C/SC NF, BUNA	134090+	SEAL KIT, 324U2, DM, SC/SC-C/SC, EPDM	133955+
SEAL KIT, 320U2, DM, C/CE-C/CE, EPDM	133871+	SEAL KIT, 324U2, DM, SC/SC-C/SC NF, EPDM	134018+
SEAL KIT, 320U2, DM, SC/SC-C/SC, EPDM	133949+	SEAL KIT, 324U2, DM, TC/SC-C/SC NF, EPDM	134098+
SEAL KIT, 320U2, DM, SC/SC-C/SC NF, EPDM	134012+	SEAL KIT, 324U2, DM, C/CE-C/CE, FKM	133876+
SEAL KIT, 320U2, DM, TC/SC-C/SC NF, EPDM	134092+	SEAL KIT, 324U2, DM, SC/SC-C/SC, FKM	133954+
SEAL KIT, 320U2, DM, C/CE-C/CE, FKM	133870+	SEAL KIT, 324U2, DM, SC/SC-C/SC NF, FKM	134017+
SEAL KIT, 320U2, DM, SC/SC-C/SC, FKM	133948+	SEAL KIT, 324U2, DM, TC/SC-C/SC NF, FKM	134097+
SEAL KIT, 320U2, DM, SC/SC-C/SC NF, FKM	134011+	SEAL KIT, 324U2, SM, C/CE, EPDM	133223+
SEAL KIT, 320U2, DM, TC/SC-C/SC NF, FKM	134091+	SEAL KIT, 324U2, SM, C/SC, EPDM	134572+
SEAL KIT, 320U2, SM, C/SC, EPDM	134569+	SEAL KIT, 324U2, SM, SC/SC, EPDM	133557+
SEAL KIT, 320U2, SM, SC/SC, EPDM	133551+		

Notes:

320U2 kits apply to 320-, 370-U2

Abbreviation Key:

SM Single Mechanical
DM Double Mechanical
C Carbon
SC Silicon Carbide
TC Tungsten Carbide
NF Narrow Face

Seal kit nomenclature

Single seal: Example: SEAL KIT, 015U2, SM, C/SC, FKM:

SEAL KIT, Pump size (**015U2**) , Seal type (**SM**) , Inner Seat (**C**) / Seal Seat (**TC**) , elastomers (**FKM**)

Double seal: Example: SEAL KIT, 015U2, DM, C/SC-C/SC, FKM:

SEAL KIT, Pump size (**015U2**) , Seal type (**DM**) , Inner Seat (**C**) / Seal Seat (**SC**) - Outer seal (**C**) / Seal seat (**SC**) , elastomers (**FKM**)

Triple Lip Seal Kits

Part No.	DESCRIPTION	LIP SEAL (2)	SLEEVE (2)	COVER O-RING (1)	ROTOR NUT O-RING (2)	ROTOR RET O-RING (2)	ROTOR HUB O-RING (2)	SLEEVE O-RING (2)	RETAINER TAB (NOT INCL. IN SEAL KIT)	RET-BOLT (NOT INCL. IN SEAL KIT)
307576+	KIT, TRIP LIP SEAL 006-018U2 316L BUNA	308787+	307588+	N70249	N70126	N70112	N70121	N70026	308788+ (4)	137460+ (4)
307576V	KIT, TRIP LIP SEAL 006-018U2 316L FKM	308787+	307588+	V70249	V70126	V70112	V70121	V70026	308788+ (4)	137460+ (4)
307576E	KIT, TRIP LIP SEAL 006-018U2 316L EPDM	308787+	307588+	E70249	E70126	E70112	E70121	E70026	308788+ (4)	137460+ (4)
307576S	KIT, TRIP LIP SEAL 006-018U2 316L SILICONE	308787+	307588+	S75249	S75126	S75112	S75121	S75026	308788+ (4)	137460+ (4)
307576K	KIT, TRIP LIP SEAL 006-018U2 316L FFKM	308787+	307588+	K70249	K70126	K70112	K70121	K70026	308788+ (4)	137460+ (4)
307577+	KIT, TRIP LIP SEAL 006-018U2 SC BUNA	308787+	308774+	N70249	N70126	N70112	N70121	N70026	308788+ (4)	137460+ (4)
307577V	KIT, TRIP LIP SEAL 006-018U2 SC FKM	308787+	308774+	V70249	V70126	V70112	V70121	V70026	308788+ (4)	137460+ (4)
307577E	KIT, TRIP LIP SEAL 006-018U2 SC EPDM	308787+	308774+	E70249	E70126	E70112	E70121	E70026	308788+ (4)	137460+ (4)
307577S	KIT, TRIP LIP SEAL 006-018U2 SC SILICONE	308787+	308774+	S75249	S75126	S75112	S75121	S75026	308788+ (4)	137460+ (4)
307577K	KIT, TRIP LIP SEAL 006-018U2 SC FFKM	308787+	308774+	K70249	K70126	K70112	K70121	K70026	308788+ (4)	137460+ (4)
307578+	KIT, TRIP LIP SEAL 030-040U2 316L BUNA	310098+	307589+	N70259	N70130	N70115	N70127	N70030	308788+ (4)	137460+ (4)
307578V	KIT, TRIP LIP SEAL 030-040U2 316L FKM	310098+	307589+	V70259	V70130	V70115	V70127	V70030	308788+ (4)	137460+ (4)
307578E	KIT, TRIP LIP SEAL 030-040U2 316L EPDM	310098+	307589+	E70259	E70130	E70115	E70127	E70030	308788+ (4)	137460+ (4)
307578S	KIT, TRIP LIP SEAL 030-040U2 316L SILICONE	310098+	307589+	S75259	S75130	S75115	S75127	S75030	308788+ (4)	137460+ (4)
307578K	KIT, TRIP LIP SEAL 030-040U2 316L FFKM	310098+	307589+	K70259	K70130	K70115	K70127	K70030	308788+ (4)	137460+ (4)
307579+	KIT, TRIP LIP SEAL 030-040U2 SC BUNA	310098+	310099+	N70259	N70130	N70115	N70127	N70030	308788+ (4)	137460+ (4)
307579V	KIT, TRIP LIP SEAL 030-040U2 SC FKM	310098+	310099+	V70259	V70130	V70115	V70127	V70030	308788+ (4)	137460+ (4)
307579E	KIT, TRIP LIP SEAL 030-040U2 SC EPDM	310098+	310099+	E70259	E70130	E70115	E70127	E70030	308788+ (4)	137460+ (4)
307579S	KIT, TRIP LIP SEAL 030-040U2 SC SILICONE	310098+	310099+	S75259	S75130	S75115	S75127	S75030	308788+ (4)	137460+ (4)
307579K	KIT, TRIP LIP SEAL 030-040U2 SC FFKM	310098+	310099+	K70259	K70130	K70115	K70127	K70030	308788+ (4)	137460+ (4)
307580+	KIT, TRIP LIP SEAL 045-130U2 316L BUNA	310918+	307590+	N70373	N70227	N70119	N70224	N70136	308788+ (4)	137460+ (4)
307580V	KIT, TRIP LIP SEAL 045-130U2 316L FKM	310918+	307590+	V70373	V70227	V70119	V70224	V70136	308788+ (4)	137460+ (4)
307580E	KIT, TRIP LIP SEAL 045-130U2 316L EPDM	310918+	307590+	E70373	E70227	E70119	E70224	E70136	308788+ (4)	137460+ (4)
307580S	KIT, TRIP LIP SEAL 045-130U2 316L SILICONE	310918+	307590+	S75373	S75227	S75119	S75224	S75136	308788+ (4)	137460+ (4)
307580K	KIT, TRIP LIP SEAL 045-130U2 316L FFKM	310918+	307590+	K70373	K70227	K70119	K70224	K70136	308788+ (4)	137460+ (4)
307581+	KIT, TRIP LIP SEAL 045-130U2 SC BUNA	310918+	310920+	N70373	N70227	N70119	N70224	N70136	308788+ (4)	137460+ (4)
307581V	KIT, TRIP LIP SEAL 045-130U2 SC FKM	310918+	310920+	V70373	V70227	V70119	V70224	V70136	308788+ (4)	137460+ (4)
307581E	KIT, TRIP LIP SEAL 045-130U2 SC EPDM	310918+	310920+	E70373	E70227	E70119	E70224	E70136	308788+ (4)	137460+ (4)
307581S	KIT, TRIP LIP SEAL 045-130U2 SC SILICONE	310918+	310920+	S75373	S75227	S75119	S75224	S75136	308788+ (4)	137460+ (4)
307581K	KIT, TRIP LIP SEAL 045-130U2 SC FFKM	310918+	310920+	K70373	K70227	K70119	K70224	K70136	308788+ (4)	137460+ (4)
307582+	KIT, TRIP LIP SEAL 180-220U2 316L BUNA	310338+	307591+	N70381	N70235	N70122	N70230	N70148	308788+ (4)	137460+ (4)
307582V	KIT, TRIP LIP SEAL 180-220U2 316L FKM	310338+	307591+	V70381	V70235	V70122	V70230	V70148	308788+ (4)	137460+ (4)
307582E	KIT, TRIP LIP SEAL 180-220U2 316L EPDM	310338+	307591+	E70381	E70235	E70122	E70230	E70148	308788+ (4)	137460+ (4)
307582S	KIT, TRIP LIP SEAL 180-220U2 316L SILICONE	310338+	307591+	S75381	S75235	S75122	S75230	S75148	308788+ (4)	137460+ (4)
307582K	KIT, TRIP LIP SEAL 180-220U2 316L FFKM	310338+	307591+	K70381	K70235	K70122	K70230	K70148	308788+ (4)	137460+ (4)
307583+	KIT, TRIP LIP SEAL 180-220U2 SC BUNA	310338+	310336+	N70381	N70235	N70122	N70230	N70148	308788+ (4)	137460+ (4)
307583V	KIT, TRIP LIP SEAL 180-220U2 SC FKM	310338+	310336+	V70381	V70235	V70122	V70230	V70148	308788+ (4)	137460+ (4)
307583E	KIT, TRIP LIP SEAL 180-220U2 SC EPDM	310338+	310336+	E70381	E70235	E70122	E70230	E70148	308788+ (4)	137460+ (4)
307583S	KIT, TRIP LIP SEAL 180-220U2 SC SILICONE	310338+	310336+	S75381	S75235	S75122	S75230	S75148	308788+ (4)	137460+ (4)
307583K	KIT, TRIP LIP SEAL 180-220U2 SC FFKM	310338+	310336+	K70381	K70235	K70122	K70230	K70148	308788+ (4)	137460+ (4)
307584+	KIT, TRIP LIP SEAL 210U2 316L BUNA	310341+	307592+	N70382	N70237	N70125	N70232	N70151	308788+ (4)	137460+ (4)
307584V	KIT, TRIP LIP SEAL 210U2 316L FKM	310341+	307592+	V70382	V70237	V70125	V70232	V70151	308788+ (4)	137460+ (4)
307584E	KIT, TRIP LIP SEAL 210U2 316L EPDM	310341+	307592+	E70382	E70237	E70125	E70232	E70151	308788+ (4)	137460+ (4)
307584S	KIT, TRIP LIP SEAL 210U2 316L SILICONE	310341+	307592+	S75382	S75237	S75125	S75232	S75151	308788+ (4)	137460+ (4)
307584K	KIT, TRIP LIP SEAL 210U2 316L FFKM	310341+	307592+	K70382	K70237	K70125	K70232	K70151	308788+ (4)	137460+ (4)
307585+	KIT, TRIP LIP SEAL 210U2 SC BUNA	310341+	310339+	N70382	N70237	N70125	N70232	N70151	308788+ (4)	137460+ (4)
307585V	KIT, TRIP LIP SEAL 210U2 SC FKM	310341+	310339+	V70382	V70237	V70125	V70232	V70151	308788+ (4)	137460+ (4)
307585E	KIT, TRIP LIP SEAL 210U2 SC EPDM	310341+	310339+	E70382	E70237	E70125	E70232	E70151	308788+ (4)	137460+ (4)
307585S	KIT, TRIP LIP SEAL 210U2 SC SILICONE	310341+	310339+	S75382	S75237	S75125	S75232	S75151	308788+ (4)	137460+ (4)
307585K	KIT, TRIP LIP SEAL 210U2 SC FFKM	310341+	310339+	K70382	K70237	K70125	K70232	K70151	308788+ (4)	137460+ (4)

Triple Lip Seal Kits cont'd

Part No.	DESCRIPTION	LIP SEAL (2)	SLEEVE (2)	COVER O-RING (1)	ROTAR NUT O-RING (2)	ROTAR RET O-RING (2)	ROTAR HUB O-RING (2)	SLEEVE O-RING (2)	RETAINER TAB (NOT INCL. IN SEAL KIT)	RET-BOLT (NOT INCL. IN SEAL KIT)
307586+	KIT, TRIP LIP SEAL 320-370U2 316L BUNA	310341+	307592+	N70383	N70237	N70125	N70232	N70151	308788+ (4)	137460+ (4)
307586V	KIT, TRIP LIP SEAL 320-370U2 316L FKM	310341+	307592+	V70383	V70237	V70125	V70232	V70151	308788+ (4)	137460+ (4)
307586E	KIT, TRIP LIP SEAL 320-370U2 316L EPDM	310341+	307592+	E70383	E70237	E70125	E70232	E70151	308788+ (4)	137460+ (4)
307586S	KIT, TRIP LIP SEAL 320-370U2 316L SILICONE	310341+	307592+	S75383	S75237	S75125	S75232	S75151	308788+ (4)	137460+ (4)
307586K	KIT, TRIP LIP SEAL 320-370U2 316L FFKM	310341+	307592+	K70383	K70237	K70125	K70232	K70151	308788+ (4)	137460+ (4)
307587+	KIT, TRIP LIP SEAL 320-370U2 SCL BUNA	310341+	310339+	N70383	N70237	N70125	N70232	N70151	308788+ (4)	137460+ (4)
307587V	KIT, TRIP LIP SEAL 320-370U2 SC FKM	310341+	310339+	V70383	V70237	V70125	V70232	V70151	308788+ (4)	137460+ (4)
307587E	KIT, TRIP LIP SEAL 320-370U2 SC EPDM	310341+	310339+	E70383	E70237	E70125	E70232	E70151	308788+ (4)	137460+ (4)
307587S	KIT, TRIP LIP SEAL 320-370U2 SC SILICONE	310341+	310339+	S75383	S75237	S75125	S75232	S75151	308788+ (4)	137460+ (4)
307587K	KIT, TRIP LIP SEAL 320-370U2 SC FFKM	310341+	310339+	K70383	K70237	K70125	K70232	K70151	308788+ (4)	137460+ (4)

Shaft & Bearing Assemblies

Description	Qty. per Pump	Part Number
006-014-015-U2 Drive Shaft & Bearing Assy.	1	137289+
006-014-015-U2 Short Shaft & Bearing Assy.	1	137291+
018-U2 Drive Shaft & Bearing Assy.	1	137290+
018-U2 Short Shaft & Bearing Assy.	1	137292+
30-34 U2 Drive Shaft & Bearing Assy.	1	137293+
30-34 U2 Short Shaft & Bearing Assy.	1	137294+
045-U2 Drive Shaft & Bearing Assy.	1	137296+
045-U2 Short Shaft & Bearing Assy.	1	137497+
060-064-U2 Drive Shaft & Bearing Assy.	1	137297+
060-064-U2 Short Shaft & Bearing Assy.	1	137299+
130-134-U2 Drive Shaft & Bearing Assy.	1	137298+
130-134-U2 Short Shaft & Bearing Assy.	1	137300+
180-184-U2 Drive Shaft & Bearing Assy.	1	137301+
180-184-U2 Short Shaft & Bearing Assy.	1	137304+
220-224-U2 Drive Shaft & Bearing Assy.	1	137303+
220-224-U2 Short Shaft & Bearing Assy.	1	137305+
210-214-U2 Drive Shaft & Bearing Assy.	1	137330+
210-214-U2 Short Shaft & Bearing Assy.	1	POA
320-324-U2 Drive Shaft & Bearing Assy.	1	137306+
320-324-U2 Short Shaft & Bearing Assy.	1	137307+

Notes:

1. Assembly includes items 7 or 8 (drive or short shaft), 15 (rear bearing), 16 (front bearing), 17 (gear key), and 29 (gear to rear bearing spacer). See model-specific parts list page for drawing.

Grease Seals, Bearing Retainers, and Bearing Isolator Kits

U2 Model Number	Item	Description	For pumps manufactured:		Notes
			before 7/12/04	after 7/12/04 (Newest)	
006, 014, 015, 018, 024	14	Grease Seal, Bearing Retainer, standard gearcase	000030018+	121679+	8
		Grease Seal, Bearing Retainer, SS gearcase (and some std gearcases before 7/12/04)	101716+		4
	32	Bearing Retainer, Front SS, for standard gearcase	015080000+	120332+	8
		Bearing Retainer, Front SS, for SS Gearcase or Bearing Isolator	101810+		4
		Bearing Isolator Kit, SS	X06638-1		8
030, 034, 040	14	Grease Seal, Bearing Retainer	121680+		8
	32	Bearing Retainer, Front SS, for std. lip seal	120333+		8
		Bearing Retainer, Front SS, for SS Gearcase or Bearing Isolator	101811+	122337+	2, 8
		Bearing Isolator Kit	N/A	X06639-1	2, 8
045, 060, 064, 130, 134	14	Grease Seal, Bearing Retainer	101829+		
	32	Bearing Retainer, Front CTD	N/A, use 123531+	123531+	5
		Bearing Retainer, Front SS, for std. lip seal	121828+		6
		Bearing Retainer, Front SS, used with bearing isolators.	101812+		6
		Bearing Isolator Kit, SS	X06640-2		
180, 184, 220, 224	14	Grease Seal, Bearing Retainer	N/A; use 121681+	121681+	1
	32	Bearing Retainer, Front CTD	220080000+	N/A use 121829+	
		Bearing Retainer, Front SS, for std. lip seal	121829+		8
		Bearing Retainer, Front SS, used with bearing isolators.	101813+		3, 7, 8
		Bearing Isolator Kit, SS	X06634-2		3, 7, 8
210, 213, 214, 320, 323, 324	14	Grease Seal, Bearing Retainer	N/A; use 121681+	121681+	1
	32	Bearing Retainer, Front CTD	0H1080000	N/A, use 123533+	8
		Bearing Retainer, Front SS	118365+	123533+	8
		Bearing Retainer, Front SS, used with bearing isolators.	121141+		3, 7
		Bearing Isolator Kit, SS	X06634-3		3, 7, 8

Notes: CTD = Coated Steel; SS = Stainless Steel

1. Pumps manufactured up through 1993 may take STD030005 instead (used old-style shafts). Verify serial no. to confirm.
2. 101811+ is used with bearing isolators. If isolator is needed, use part # X06639 (no kit available). Check gear case serial no. Kit X06639-1 contains bearing retainer 122337+
3. Isolator kit X06634-2 contains 101813+ bearing retainer. Isolator kit X06634-3 contains 121141+ bearing retainer.
4. 101810+ bearing retainer is used with 101716+ grease seal.
5. 123531+ is available until stock is depleted, then will be replaced by 121828+
6. 101812+ is used with bearing isolators; for std. lip seal, use part # 121828+
7. When changing to this bearing isolator, if it rubs and is very difficult to turn over, add a .010 shim to each shaft, on top of the bearing in the pump, between the bearing and the retainer.
8. When changing a pump supplied WITHOUT a bearing isolator, to one WITH a bearing isolator, order the isolator kit.

Universal 2 PD Pump Vented Covers

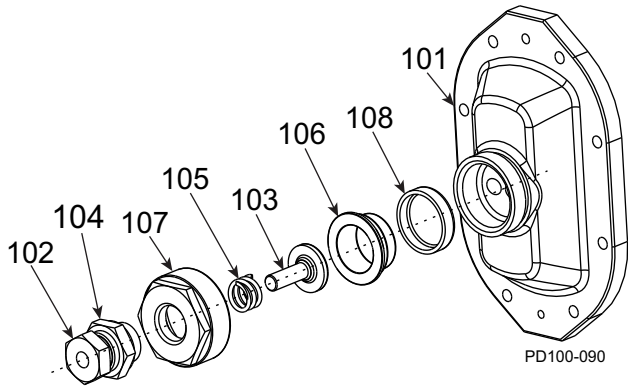

Figure 94 - Manual Vented Cover, 006-134-U2

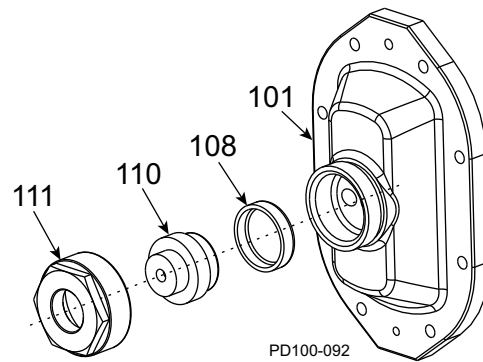
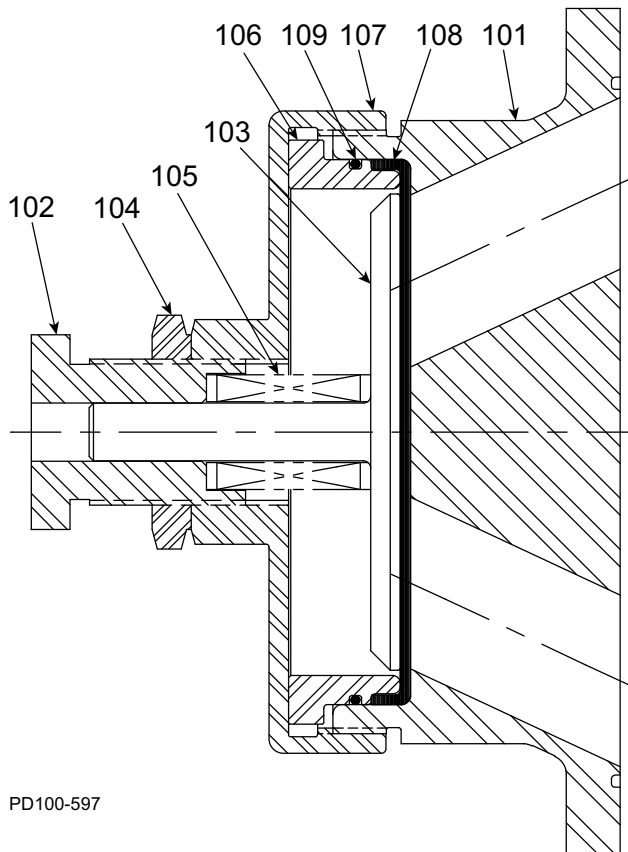

Figure 95 - Pneumatic Diaphragm Vented Cover



PD100-597

Figure 96 - Manual Vented Cover, 180-220-224 U2

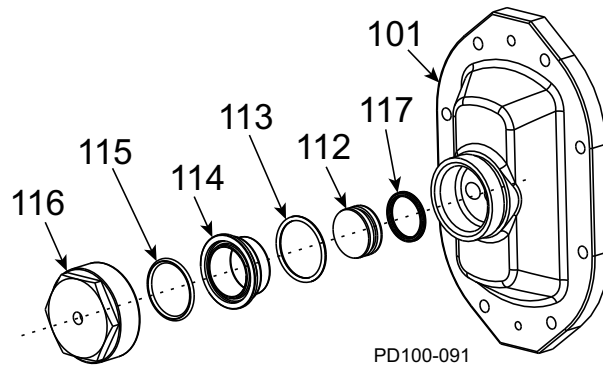

Figure 97 - Pneumatic Piston Vented Cover

Universal 2 PD Pump Vented Covers

ITEM NO.	DESCRIPTION	QTY. PER PUMP	PART NO.				NOTES
			006-014-015-018-U2	030-034-040-U2	045-060-064-130-134-U2	180-220-224-U2	
MANUAL VENTED COVER							
101	Vented Cover	1	103669+ 103670+		103671+	103672+	
102	Adjusting Screw	1	AD0072000		113657+	GD0072100	1
103	Spring Plunger	1	AD0073000		113397+	GD0073000	2
104	Locknut	1	AD0074000		GD0074000		
105	Spring, Medium (< 150 psi)	1	AD0076000		113523+	113400+	3
	Spring, High (> 150 psi)		ABB076100		113400+	113524+	4
106	Diaphragm Bushing	1	AD0077000		CD0077000	GD0077000	
107	Cover Nut	1	AD0075000		113398+	GD0075000	5
* 108	Rubber Diaphragm, Buna N	1	AD0078000		CD0078000	GD0078000	
* 109	O-ring, Buna N	1	N/A	N/A	N70261		12
	O-ring, FKM				V70261		
	O-ring, Silicone				S75261		
PNEUMATIC DIAPHRAGM VENTED COVER							
101	Vented Cover	1	103669+ 103670+		103671+	N/A	
* 108	Diaphragm, Buna N	1	AD0078000		CD0078000	N/A	
110	Diaphragm Bushing	1	AD0077P00		CD0077P00	N/A	
111	Cover Nut	1	AD0075P00		CD0075P00	N/A	
PNEUMATIC PISTON VENTED COVER							
101	Vented Cover	1	103669+ 103670+		103671+	103672+	
112	Piston	1	AD0073P10		CD0073P10	GD0073P10	
* 113	O-Ring, Bushing Seal, Buna N	1	N70223		N70239	N70261	
114	Diaphragm Bushing	1	AD0077P10		CD0077P10	GD0077P10	
* 115	O-Ring, Nut Seal, Buna N	1	N70224		N70240	N70261	
116	Cover Nut	1	AD0075P10		CD0075P10	GD0075P10	
* 117	Piston Seal, Quad Ring	1	AD0133000		CD0133000	GD0133000	9
	Piston Seal, O-Ring		N70218		N70236	N70258	9

PL5060-CH112

Notes:* **Recommended spare parts**

1. 045-060-064-130-134-U2: for pumps older than approx March 2000, use p/n AD0072000.
2. 045-060-064-130-134-U2: for pumps older than approx March 2000, use p/n CD0073000.
3. 045-060-064-130-134-U2: for pumps older than approx March 2000, use p/n AD0076000"
180-220-224-U2: for pumps older than approx March 2000, use p/n ABB076200.
4. 045-060-064-130-134-U2: for pumps older than approx March 2000, use p/n ABB076200.
180-220-224-U2: for pumps older than approx March 2000, use p/n GD0076100
5. 045-060-064-130-134-U2: for pumps older than approx March 2000, use p/n CD0075000.
9. Quad ring and O-ring can be interchanged.
12. Applies to 180, 220, and 224-U2 models only

Tru-Fit™ Universal 2 PD Pump

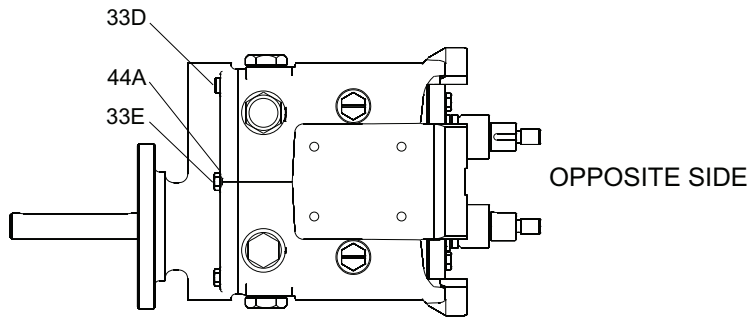
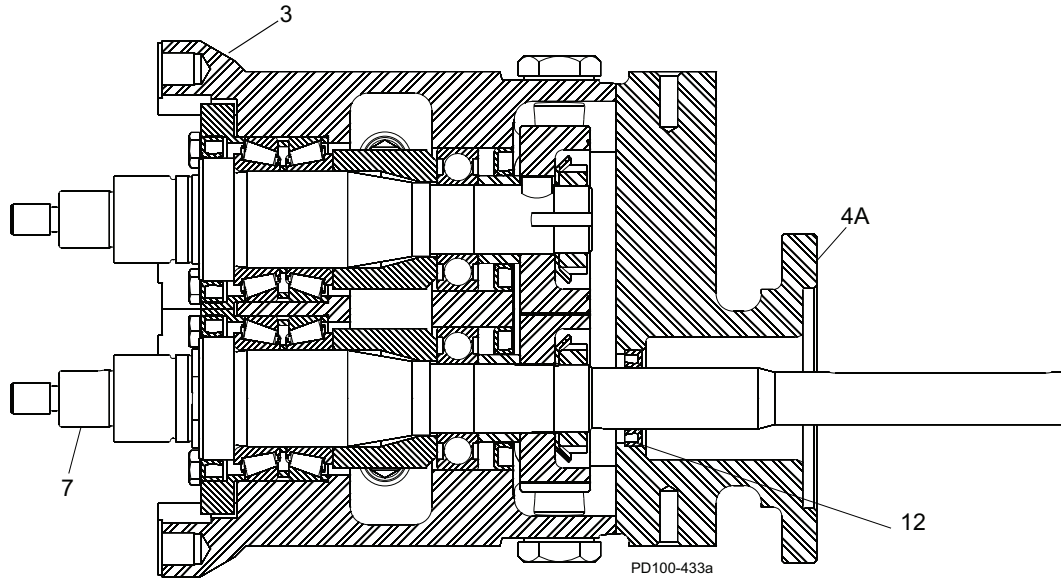

Tru-Fit™ Universal 2 PD Pump

Item No.	Description	Qty.	U2 Pump Size				Note
			006, 014, 015	018, 024	030, 034	040	
3	Gear Case, CI	1	POA		POA		3
	Gear Case, SS; Optional	1	POA		POA		3
4A	Gear Case Cover, Adapter	1	Serial number required				1
7	Drive Shaft	1	119182+	119183+	119184+	119185+	
12	Oil Seal, Adapter	1	000030016+		000030013+		2
33D	1/4-20 x 1" HHCS	4	30-93		N/A		
	5/16-18 x 1-1/8" HHCS		N/A		30-237		
33E	5/16" x 3/4" lg. SHSB	2	30-690		N/A		
	3/8" x 3/4" lg. SHSB		N/A		30-691		
44A	Flat Washer, 5/16"	4	43-246		N/A	N/A	
	Flat Washer, 3/8"		N/A		43-30		

Item No.	Description	Qty.	U2 Pump Size					Note
			045	060, 064	130, 134	180, 184	220, 224	
3	Gear Case, CI	1	POA		POA			3
	Gear Case, SS; Optional	1	POA		POA			3
4A	Gear Case Cover, Adapter	1	Serial number required					1
7	Drive Shaft	1	119186+	119187+	119188+	119189+	119190+	
12	Oil Seal, Adapter	1	000030012+			STD030006		2
33D	3/8-16 x 1-1/2" HHCS	4	30-50					
	1/2-13 x 1-1/2" HHCS		N/A					
33E	1/2" x 1" lg. SHSB	2	30-692					
	5/8" x 1" lg. SHSB		N/A					
44A	Flat Washer, 1/2"	4	43-31					

Item No.	Description	Qty.	U2 Pump Size			Note
			210, 214	320, 324	370	
3	Gear Case, CI	1	POA			3
	Gear Case, SS; Optional	1	POA			3
4A	Gear Case Cover, Adapter	1	Serial number required			1
7	Drive Shaft	1	119191+	119192+	124841+	
12	Oil Seal, Adapter	1	STD030004			2
33D	3/8-16 x 1-1/2" HHCS	4	N/A			
	1/2-13 x 1-1/2" HHCS		30-103			
33E	1/2" x 1" lg. SHSB	2	N/A			
	5/8" x 1" lg. SHSB		30-693			
44A	Flat Washer, 1/2"	4	43-31			

Note:

1. Depends on the Nord motor, material, paint. Contact customer service with serial number for part number.
2. Item 12, Oil seal, Adapter, is the same seal that is used on non-Tru-Fit pumps. It is not included with item 4A.
3. Please contact the SPX Flow Customer Service for Gear Case options.

Special Tools

Non-Marring Socket Tool for Rotor Nuts



Model U2 Pumps	Part Number
006, 014, 015, 018	140074+
030, 034, 040	139795+
045, 060, 064, 130, 134	139796+
180, 184, 220, 224	139797+
210, 213, 214, 320, 323, 324	126536+

PL5060-CH116

Gear Nut Driver, Gear End Shaft Thread Chaser

Description	Model U2 Pumps	Part Number
Gear Nut Driver	006,014,015,018	109281+
	030,034,040	109282+
	045, 060, 064, 130, 134	109283+
	180,184,220,224	110304+
	210, 213, 214, 320, 323, 324	114702+
Gear End Shaft Thread Chaser	006,014,015,018	109287+
	030,034,040	109288+
	045, 060, 064, 130, 134	109289+
	180,184,220,224	110305+

PL5060-CH129

O-ring Removal Tool

Description	Part Number
O-ring removal tool	AD0096001

PL5060-CH130

Rotor Blocking Tool

Description	Part Number
Rotor Blocking Tool	139790+

PL5060-CH164

Installation guide for the Triple Lip Seal

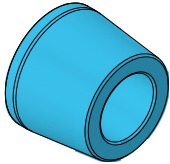
	Description	Model U2 Pumps	Part No.	QTY. Per Pump	
	Installation guide		006-018-U2	311485+	2
			030-040-U2	311486+	2
			060-130-U2	311487+	2
			180-220-U2	311488+	2
			210-370-U2	311489+	2
			320-U2	311490+	2

Long Term Storage

Long-term storage (greater than six months) of Waukesha Cherry-Burrell brand pumps:

Before Storage

1. Lubricate all bearings and seals, including:
 - Rubber o-rings and mechanical seal faces (new pump bearings installed from the factory are already lubricated).
 - Motors and drives (see manufacturer's instructions)
2. Be sure the pump contains no water. Make sure to disassemble the wet end and wipe it dry if necessary.
3. Use rust inhibitor on any exposed metal surfaces:
 - Any unpainted surfaces
 - Shafts, nuts/bolts
4. Cover the inlet/outlet connections of the pumps to keep out foreign materials.
5. Put all related instruction manuals in a separate water-tight envelope or container and store them with the equipment.
6. Completely enclose the equipment to prevent contamination from moisture, dust and other possible contaminants. Certain types of plastic wrap materials, when properly used, make excellent storage enclosures.
7. Rotate the pump and drive shafts several turns every 3 months.

Storage

1. Store in a dry location. Indoor storage is preferred. If stored outdoors, the equipment must be in a weather-tight enclosure and shielded from direct sunlight.
2. Maintain even temperatures to prevent condensation.

After Storage

NOTE: Do not start the motor if there is any indication of water contamination. Have the motor checked by a qualified electrician before starting.

1. Remove the equipment from the enclosure and repair or replace any damaged items before using equipment.
2. Check the electric motor (if applicable) per the manufacturer's instructions.
3. Pumps:
 - Completely disassemble the product contact liquid end per the instruction manual.
 - Clean and inspect all parts, including seals and o-rings.
 - Replace rubber parts with any sign of age or damage, such as cracks, taking a set, or loss of elasticity.
4. Lubricate the seal and o-rings and reassemble the liquid end per the instruction manual.
5. Purge pump bearings with fresh grease.
6. Lubricate the motor/drive (if applicable) per the manufacturer's instructions.
7. If the pump has been in storage longer than 1 year, change the oil in the pump and drive.

Pump Dimensions

Universal 2 PD Pump Dimensions

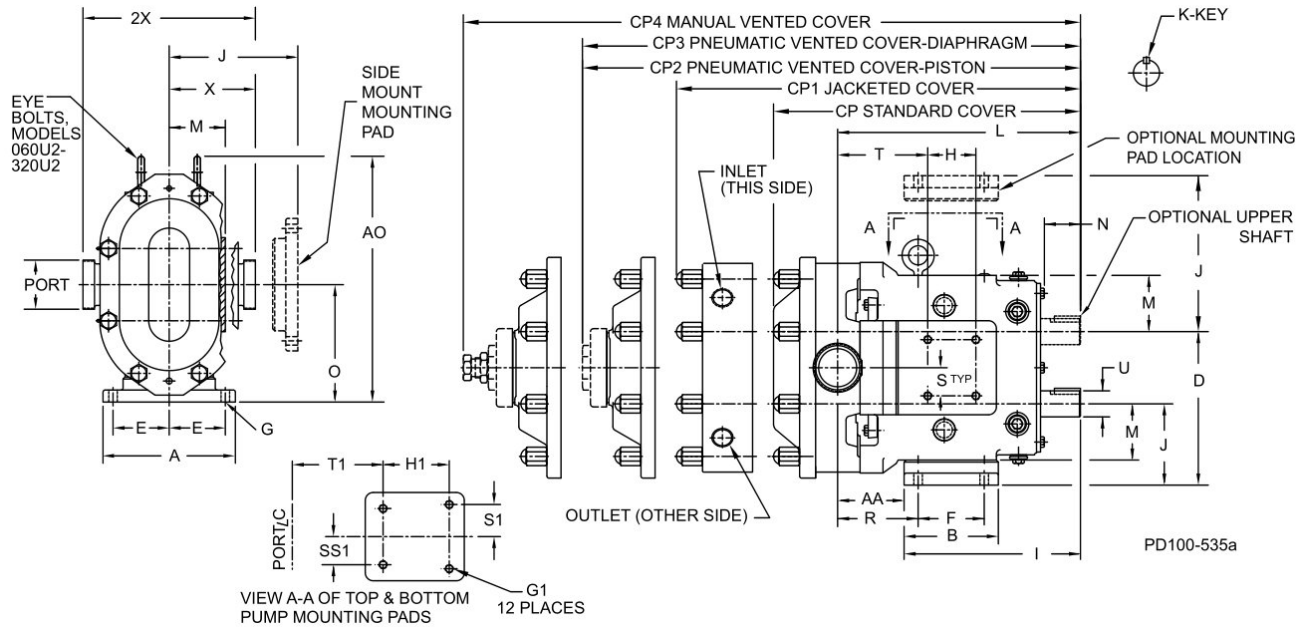

U2 Model		A	AA	AO	B	CP	CP1	CP2	CP3	CP4	D	E	F	G	G1
6	inch	4.75	1.95	8.3	3.75	11.71	13.92	13.2	13.29	14.92	5.5	1.94	2.31	.41, slot	5/16-18x.62
	mm	121	50	211	95	297	354	335	338	379	140	49	59	10, slot	-
15	inch	4.75	1.95	8.3	3.75	11.71	13.92	13.2	13.29	14.92	5.5	1.94	2.31	.41, slot	5/16-18x.62
	mm	121	50	211	95	297	354	335	338	379	140	49	59	10 slot	-
18	inch	4.75	2.18	8.3	3.75	12.37	14.59	13.86	13.95	15.58	5.5	1.94	2.31	.41, slot	5/16-18x.62
	mm	121	55	211	95	314	371	352	354	396	140	49	59	10 slot	-
30	inch	6.25	2.78	10.29	4.25	14.49	16.49	15.89	15.98	17.58	6.86	2.31	2.56	.41, slot	3/8-16x.62
	mm	159	71	261	108	368	419	404	406	447	174	59	65	10 slot	-
40	inch	6.25	2.99	10.29	4.25	14.87	16.87	16.27	16.36	17.96	6.86	2.31	2.56	.41, slot	3/8-16x.62
	mm	159	76	261	108	378	428	413	416	456	174	59	65	10 slot	-
45	inch	8.25	3.86	15.31	5.87	18.59	20.7	20.68	20.97	22.28	9.56	3.50	4.12	.53, slot	1/2-13x.88
	mm	210	98	389	149	472	526	525	533	566	243	89	105	13, slot	-
60	inch	8.25	4.14	15.31	5.87	19.14	21.25	21.23	21.52	22.83	9.56	3.50	4.12	0.53	1/2-13x.88
	mm	210	105	389	149	486	540	539	547	580	243	89	105	13	-
130	inch	8.25	4.78	15.31	5.87	20.15	22.27	22.25	22.53	23.84	9.56	3.50	4.12	0.53	1/2-13x.88
	mm	210	121	389	149	512	566	565	572	606	243	89	105	13	-
180	inch	8.5	3.45	19.13	9	23.26	25.32	26.71	N/A	28.51	12.38	3.75	7.25	.53, slot	1/2-13x.88
	mm	216	88	486	229	591	643	678	-	724	314	95	184	13, slot	-
210	inch	12	3.45	22.38	11.63	27.08	28.58	-	-	-	13.88	5.25	8.00	0.66	1/2-13x.88
	mm	305	88	568	295	688	726	-	-	-	353	133	203	17	-
213	inch	12	3.45	22.38	11.63	27.08	-	-	-	-	13.88	5.25	8.00	0.66	1/2-13x.88
	mm	305	88	568	295	688	-	-	-	-	353	133	203	17	-
220	inch	8.5	3.69	19.13	9	24	26.06	27.45	-	29.25	12.38	3.75	7.25	.53, slot	1/2-13x.88
	mm	216	94	486	229	610	662	713	-	743	314	95	184	13, slot	-
320	inch	12	3.84	22.38	11.63	27.66	29.16	-	-	-	13.88	5.25	8.00	0.66	1/2-13x.88
	mm	305	97	568	295	703	741	-	-	-	353	133	203	17	-
370	inch	12	4.53	22.38	11.63	29.16	30.66	-	-	-	13.88	5.25	8.00	0.66	1/2-13x.88
	mm	305	115	568	295	741	779	-	-	-	353	133	203	17	-

PD100-534

Universal 2 PD Pump Dimensions

U2 Model		H	H1	I	J	K +002 -.000	L	M	N	O	Port Size	R	S	S1	SS1	T	T1	U +002 -.000	X	2X
6	inch	2.50	2.50	7.66	2.93	.1875	9.61	2.12	2	4.21	1"	2.79	1.00	1.00	1.00	2.51	2.51	0.875	3.49	6.97
	mm	64	64	194	74	4.763	244	54	51	107	--	71	25	25	25	64	64	22.23	89	177
15	inch	2.50	2.50	7.66	2.93	.1875	9.61	2.12	2.00	4.21	1-1/2"	2.79	1.00	1.00	1.00	2.51	2.51	0.875	3.49	6.97
	mm	64	64	194	74	4.763	244	54	51	107	--	71	25	25	25	64	64	22.23	89	177
18	inch	2.50	2.50	7.66	2.93	.1875	9.84	2.12	2.00	4.21	1-1/2"	3.02	1.00	1.00	1.00	2.74	2.51	0.875	3.55	7.09
	mm	64	64	194	74	4.763	250	54	51	107	--	77	25	25	25	70	64	22.23	89	177
30	inch	1.81	2.75	8.83	3.56	0.25	11.61	2.62	2.32	5.21	1-1/2"	3.84	1.12	1.12	1.12	4.00	3.59	1.25	4.25	8.50
	mm	46	70	224	90	6.35	295	67	59	132	--	97.5	28	28	28	102	91	31.75	108	216
40	inch	1.81	2.75	8.83	3.56	0.25	11.99	2.62	2.32	5.21	2"	4.00	1.12	1.12	1.12	4.38	3.97	1.25	4.31	8.62
	mm	46	70	224	90	6.35	305	67	59	132	--	102	28	28	28	111	101	31.75	109	219
45	inch	3.00	4.13	10.99	5.06	0.375	14.86	3.50	2.25	7.31	2"	4.73	1.75	2.00	1.75	5.34	5.01	1.625	5.37	10.75
	mm	76	105	279	129	9.525	377	89	57	186	--	120	44	51	44	136	127	41.28	136	273
60	inch	3.00	4.13	10.99	5.06	0.375	15.14	3.50	2.25	7.31	2-1/2"	5.01	1.75	2.00	1.75	5.62	5.01	1.625	5.37	10.75
	mm	76	105	279	129	9.525	385	89	57	186	--	127	44	51	44	143	127	41.28	136	273
130	inch	3.00	4.13	10.99	5.06	0.375	15.77	3.50	2.25	7.31	3"	5.65	1.75	2.00	1.75	6.25	5.66	1.625	5.37	10.75
	mm	76	105	279	129	9.525	401	89	57	186	--	144	44	51	44	159	144	41.28	136	273
180	inch	5.38	5.38	14.80	6.38	0.5	18.25	4.50	2.75	9.38	3"	4.20	2.69	2.69	2.69	5.76	6.00	2.00	6.53	13.06
	mm	137	137	376	162	12.7	464	114	70	238	--	107	68	68	68	146	152	50.8	168	332
210	inch	5.38	5.38	17.80	6.88	0.625	21.24	5.06	4.06	10.38	4"	4.70	2.69	2.69	2.69	7.83	7.83	2.375	7.37	14.73
	mm	137	137	452	175	15.88	539	129	103	264	--	119	68	68	68	199	199	60.45	187	374
213	inch	5.38	5.38	17.80	6.88	0.625	21.24	5.06	4.06	10.38	4" 300# FLG	4.70	2.69	2.69	2.69	7.83	7.83	2.375	8.62	17.25
	mm	137	137	452	175	15.88	539	129	103	264	--	119	68	68	68	199	199	60.45	219	438
220	inch	5.38	5.38	14.80	6.38	0.50	18.49	4.50	2.75	9.38	4"	4.44	2.69	2.69	2.69	6.00	6.00	2.00	6.63	13.25
	mm	137	137	376	162	12.7	470	114	70	238	--	113	68	68	68	152	152	50.80	168	337
320	inch	5.38	5.38	17.80	6.88	0.625	21.63	5.06	4.03	10.38	6" 150# FLG	5.09	2.69	2.69	2.69	8.22	8.22	2.375	8.00	16.00
	mm	137	137	452	175	15.88	549	129	103	264	--	129	68	68	68	209	209	60.45	203	406
370	inch	5.38	5.38	17.80	6.88	0.625	22.32	5.06	4.06	10.38	6" 150# FLG	5.78	2.69	2.69	2.69	8.91	8.91	2.375	8.50	17.00
	mm	137	137	452	175	15.88	567	129	103	264	--	147	68	68	68	226	226	60.45	216	432

PD100-534b

Note:

Dimensions 'X' and '2X' apply for bevel seat, 'S' Clamp, 'Q' Clamp, 15I and 14I fittings (except 213U2 & 320U2).
 CP= Standard Cover, CP1= Jacketed Cover, CP4= Manual Vented Cover.
 Connection Sizes for Jacketed Covers are 3/4" NPT on Models 006 to 030U2; 1" NPT on Models 045 to 370U2.

Rectangular Flange Universal 2 PD Pump Dimensions

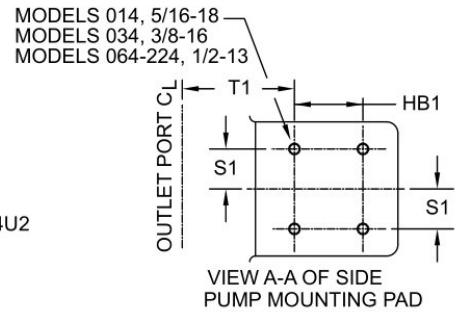
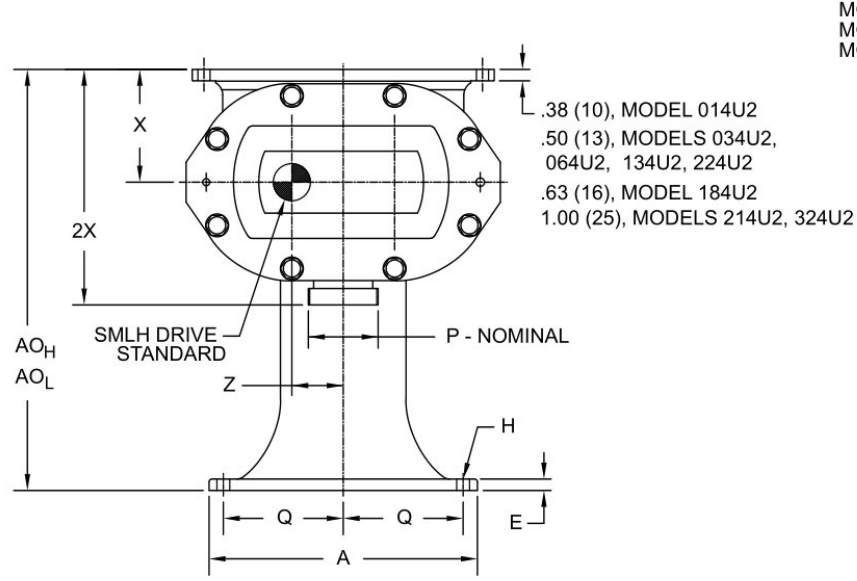
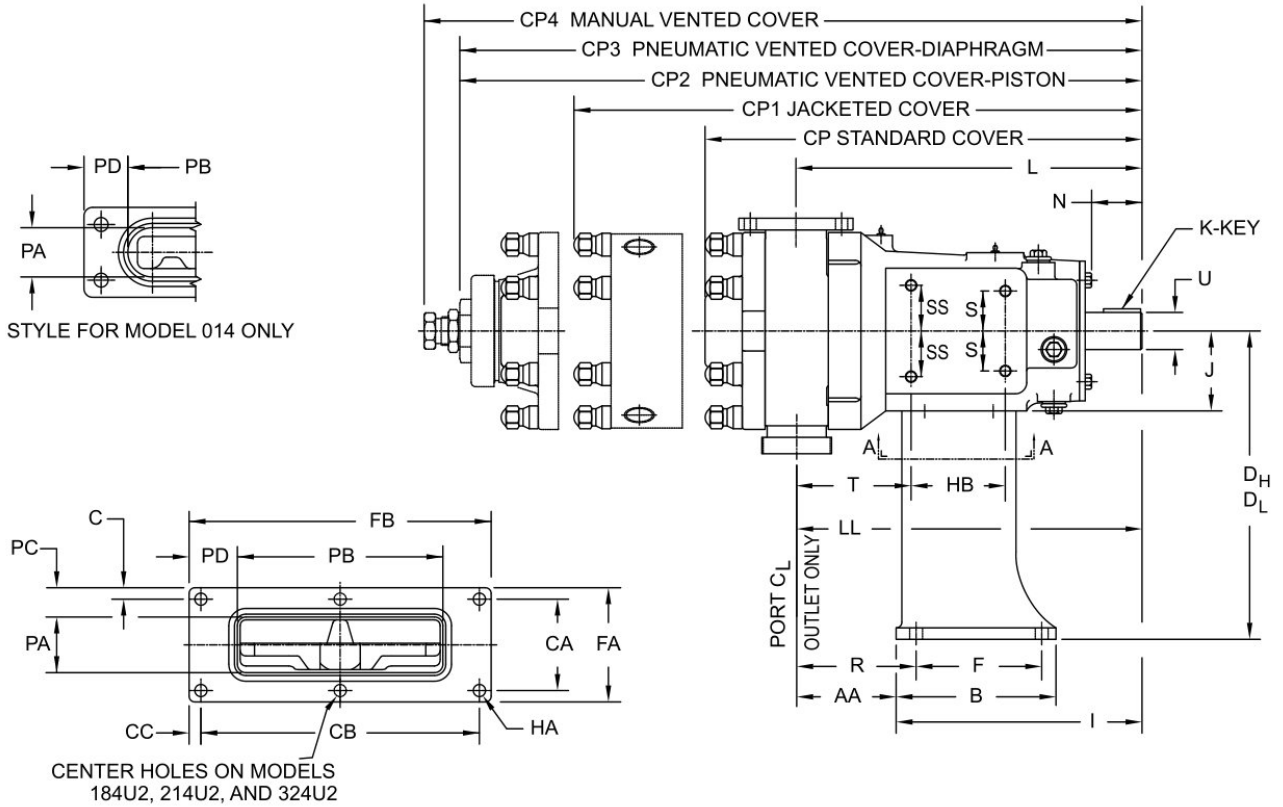

PD100-536

Rectangular Flange Universal 2 PD Pump Dimensions

U2 RF Model		A	AA	AOL	B	C	CA	CB	CC	CP	CP1	CP4	DL	E	F	FA
14	inch	6.75	1.95	12.5	4.13	0.5	1.62	6.5	0.5	11.71	13.92	14.92	8.88	0.38	2.31	2.63
	mm	171	50	318	105	13	41	165	13	297	354	379	226	10	59	67
34	inch	8	2.88	12.75	4.25	0.62	1.88	10.75	0.62	14.49	16.49	17.58	8.88	0.38	3	3.12
	mm	203	73	324	108	16	48	273	16	368	419	447	226	10	76	79
64	inch	11.75	4.35	13.94	7	0.5	4	12.2	0.52	19.14	21.25	22.83	9	0.5	5.5	5
	mm	298	110	354	178	13	102	310	13	486	540	580	229	13	140	127
134	inch	11.75	5	13.94	7	0.78	3	14	0.63	20.15	22.27	23.84	9	0.5	5.5	4.55
	mm	298	127	354	178	20	76	356	16	512	566	606	229	13	140	116
184	inch	15	4.32	20.75	9.5	0.63	5.75	16.75	0.63	23.26	25.32	28.51	13.5	0.63	8.25	7
	mm	381	110	527	241	16	146	425	16	591	643	724	343	16	210	178
214	inch	18	4.38	35.94	12	0.75	7.5	16.5	0.75	27.08	28.58	-	27.13	0.75	9.5	9
	mm	457	111	913	305	19	190	419	19	688	726	-	689	19	241	229
224	inch	15	4.75	19.75	9.5	0.63	4.37	16.75	0.63	24	26.06	29.25	13.5	0.63	8.25	5.62
	mm	381	121	502	241	16	111	425	16	610	662	743	343	16	210	143
324	inch	18	4.79	35.94	12	0.81	8	16.5	0.75	27.66	29.16	-	27.13	0.75	9.5	9.63
	mm	457	122	913	305	21	203	419	19	703	741	-	689	19	241	245

U2 RF Model		FB	H	HA	I	J	L	P	PA	PB	PC	PD	U	X	2X
14	inch	7.5	0.41	0.41	7.66	2.12	9.61	1-1/2"	1.44	4.94	0.59	1.28	0.875	3.63	7.11
	mm	191	10	10	195	54	244	--	37	125	15	33	22.23	92	181
34	inch	12	0.44	0.53	8.49	2.62	11.36	2"	1.81	6.84	0.66	2.58	1.25	3.88	8.12
	mm	305	11	13	216	67	289	--	46	174	17	66	31.75	99	206
64	inch	13.23	0.56	0.53	10.77	3.5	15.16	2-1/2"	2.44	9	1.28	2.11	1.625	4.94	10.31
	mm	336	14	13	274	89	385	--	62	229	33	54	41.28	125	262
134	inch	15.25	0.56	0.53	10.77	3.5	15.78	3"	3.19	9.38	0.68	2.94	1.625	4.94	10.31
	mm	387	14	13	274	89	401	--	81	238	17	75	41.28	125	262
184	inch	18	0.56	0.53	13.74	4.5	18.31	3"	3.28	11.25	1.86	3.38	2	7.25	13.78
	mm	457	14	13	349	114	465	--	83	286	47	86	50.8	184	350
214	inch	18	0.69	0.69	16.86	5.06	21.26	4"	3.45	12.7	2.78	2.65	2.375	8.81	16.17
	mm	457	18	18	428	129	540	--	88	323	71	67	60.33	224	411
224	inch	18	0.56	0.53	13.74	4.5	18.49	4"	4.06	11.25	0.78	3.38	2	6.25	12.87
	mm	457	14	13	349	114	470	--	103	286	20	86	50.8	159	327
324	inch	18	0.69	0.69	16.86	5.06	21.63	6"	4.25	12.7	2.69	2.65	2.375	8.81	17.81
	mm	457	18	18	428	129	549	--	108	323	68	67	60.33	224	452

PD100-537

Note:

Dimension '2X' applies for bevel seat, 'S' Clamp, 'Q' Clamp, 15I and 14I fittings.

CP= Standard Cover, CP1= Jacketed Cover, CP4= Manual Vented Cover.

Connection Sizes for Jacketed Covers are 3/4" NPT on Models 014 to 034; 1" NPT on Models 064-324.

Tru-Fit™ Universal 2 PD Pump Dimensions

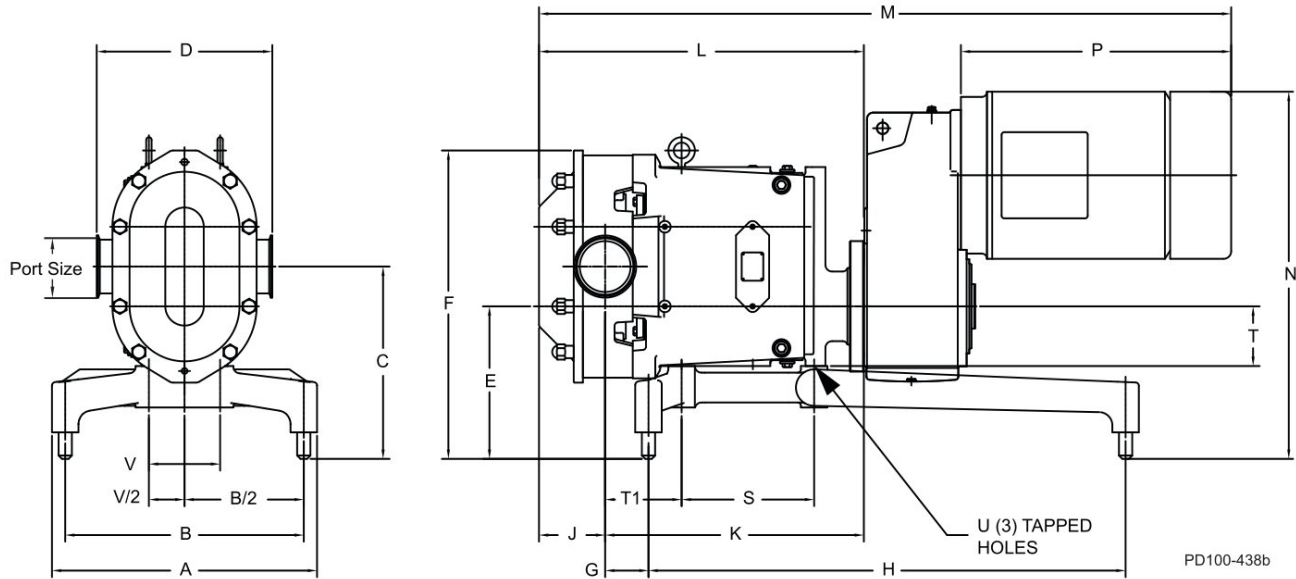

Table of Dimensions

U2 Model		A	B	C	D ²	E	F	G	H	J	K	L	M ¹	N ¹	P ¹	S	T	T1	Port Size	U	V
006	in.	12.0	10.0	9.15	6.97	7.87	13.25	2.01	18.0	2.11	10.08	12.19	27.31	15.56	10.92	5.44	2.12	2.51	1-1/2"	5/16-18 x .62	2.0
	mm	305	254	232	177	200	337	51	457	54	256	310	394	395	227	138	54	64	--	N/A	51
015	in.	12.0	10.0	9.15	6.97	7.87	13.25	2.01	18.0	2.11	10.08	12.19	27.31	15.56	10.92	5.44	2.12	2.51	1-1/2"	5/16-18 x .62	2.0
	mm	304	254	232	177	200	337	51	457	54	256	310	694	395	227	138	54	64	--	N/A	51
018	in.	12.0	10.0	9.15	7.10	7.87	13.25	2.25	18.0	2.54	10.31	12.85	27.31	15.56	10.92	5.44	2.12	2.51	1-1/2"	5/16-18 x .62	2.0
	mm	304	254	232	180	200	337	57	457	65	262	326	694	395	227	138	54	64	--	N/A	51
030	in.	14.0	12.0	10.02	8.51	8.37	15.11	2.59	20.0	2.87	12.47	15.34	33.57	18.65	13.74	5.81	2.62	3.59	1-1/2"	3/8-16 x .62	2.25
	mm	356	304	255	216	213	384	66	508	73	317	390	853	474	349	148	67	91	--	N/A	57
040	in.	14.0	12.0	10.02	8.62	8.37	15.11	2.97	20.0	2.87	12.84	15.71	33.94	18.65	13.74	5.81	2.62	3.97	2"	3/8-16 x .62	2.25
	mm	356	305	255	219	213	384	75	508	73	326	399	862	474	349	148	67	101	--	N/A	57
045	in.	18.0	16.0	12.0	10.74	9.75	20.0	2.73	28.0	4.0	17.11	21.11	43.72	22.02	17.16	8.13	3.5	5.01	2"	1/2-13 x .88	3.5
	mm	457	406	305	273	248	508	69	711	102	435	536	1110	559	436	207	89	127	--	N/A	89
060	in.	18.0	16.0	12.0	10.74	9.75	20.0	3.01	28.0	4.0	17.39	21.39	44.0	22.02	17.16	8.13	3.5	5.01	2-1/2"	1/2-13 x .88	3.5
	mm	457	406	305	273	248	508	76	711	102	442	543	1118	559	436	207	89	127	--	N/A	89
130	in.	18.0	16.0	12.0	10.74	9.75	20.0	3.64	28.0	4.38	18.02	22.4	45.01	22.02	17.16	8.13	3.5	5.66	3"	1/2-13 x .88	3.5
	mm	457	406	305	273	248	508	92	711	111	458	569	1143	559	436	207	89	144	--	N/A	89
180	in.	20.0	18.0	14.5	13.06	11.5	23.25	3.27	36.0	4.99	19.52	24.51	50.02	25.91	18.82	10.0	4.5	6	3"	1/2-13 x 1.0	5.38
	mm	508	457	368	332	292	591	83	914	127	496	623	1271	658	478	254	114	152	--	N/A	137
220	in.	20.0	18.0	14.5	13.25	11.5	23.25	3.51	36.0	5.49	19.76	25.25	50.76	25.91	18.82	10.0	4.5	6	4"	1/2-13 x 1.0	5.38
	mm	508	457	368	337	292	591	89	914	139	502	641	1289	658	478	254	114	152	--	N/A	137

PD100-439

¹ Dimensions affected by motor frame size

² Dimensions affected by connection type

Pump Shaft Guards

⚠ WARNING

Full guards must be installed to isolate operators and maintenance personnel from rotating components.

Guards are provided as part of a complete pump and drive package and are selected by SPX FLOW Engineering for the pump, base, and motor ordered. Do not modify the guard provided by SPX FLOW. If the guard provided by SPX FLOW is lost, contact SPX FLOW Customer Service and provide your order number or PO number of the pump to order a correctly-sized replacement guard.

If the pump was not purchased as a unit, it is the responsibility of the customer to ensure proper guarding. Refer to your local regulations for guidance.

Guard (side view) shown as supplied with an SPX FLOW base package

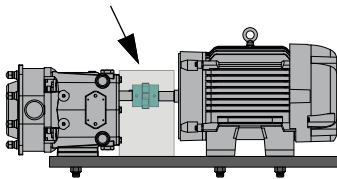

Top view

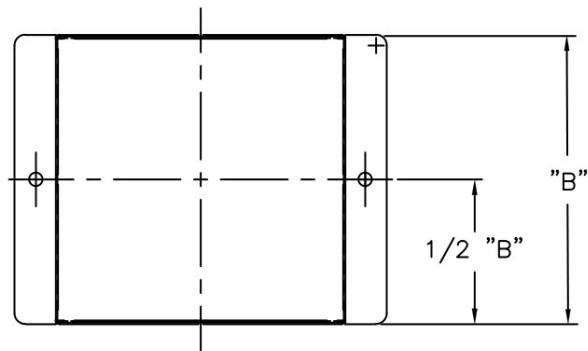

Front view

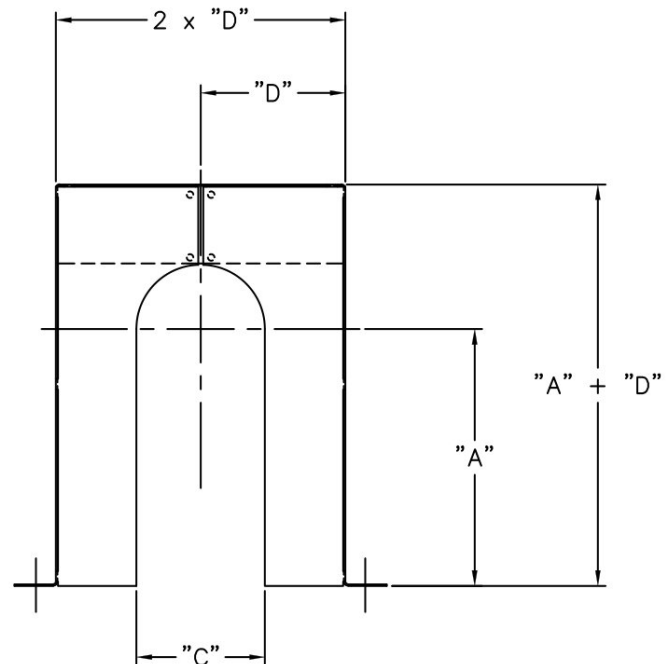

NOTE: Dimensions A, B, C, and D depend on the specific pump unit configuration.

ATEX Declaration for Universal 2

1. The ATEX declaration of incorporation must be included with the order. The declaration on the next page is not valid but is supplied for example purposes only. Please see the certificate you received with your order for your serial number.
2. The sight glass in the gear case is not approved; black plugs must be installed on all drain/level ports.
3. Only Waukesha Cherry-Burrell brand spare parts are allowed to be installed into the pump. Use of non-Waukesha Cherry-Burrell brand parts will void ATEX approval.
4. For ATEX applications, the maximum operating temperature of the pump is 220°F (108°C).
5. The pumps must be supplied with a double mechanical seal with flush in the following cases:
 - In connection with all T4 approvals
 - If media viscosities are higher than 200cP
 - Flushing media requirements for double mechanical seals:
 - Flow: minimum 0.13 gpm (0.5 l/min)
 - Temperature: maximum 104°F (40°C)
 - Pressure, atmosphere side: maximum 218 psi (15 bar)
 - Viscosity: maximum 10cP
 - Differential pressure from atmosphere to product side: maximum 102 psi (7 bar)
6. T2 classification allows for either single or double mechanical seals.

Nameplates

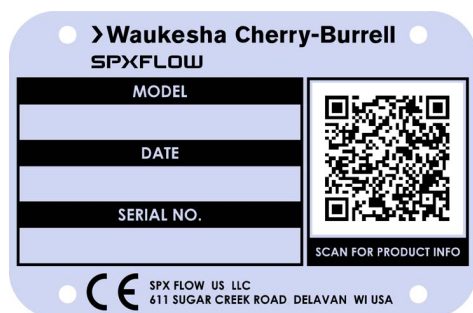

Figure 98 - Standard pump nameplate



Figure 99 - ATEX Nameplates

Pump identification

The standard pump nameplate identifies the pump model, date of manufacture, and serial number. See Figure 98.

In addition to the standard pump nameplate, an ATEX pump has ATEX nameplate identifying the operating conditions for explosive environments. See Figure 99.

Hazard class identification

See Figure 99.

- II Equipment group
- 2 Equipment category (zone 1 and 2)
- G Hazardous Gas Atmosphere.
- h Constructional Safety 'c' and Liquid Immersion 'k'
- IIB Ethylene and related gas environment.
- T4 Temperature class to max. < 275°F (135°C)
- T2 Temperature class to max. <572°F (300°C)
- Gb Equipment Protection Level for Category 2G

The ambient temperature should be between -4°F and 104°F (-20°C and 40°C). If not, contact SPX FLOW Application Engineering.

Declaration of Conformity SPXFLOW

Product

Nomenclature : **Rotary Positive Displacement Pumps.**
 Model / Type : Universal 2 and Universal 3.
 Variants / Family code : 006-U2 015-U2 018-U2 030-U2 040-U2 045-U2
 060-U2 130-U2 180-U2 210-U2 213-U2 220-U2
 320-U2 370-U2.
 006-U3 015-U3 018-U3 030-U3 040-U3 045-U3
 060-U3 130-U3 180-U3 210-U3 220-U3 320-U3.
 Serial Number : Please see the certificate received with your order for your serial number. This certificate only provides an example of SPX FLOW's Declaration.

Manufacturer

Name : **SPX Flow US, LLC.**
 Address : 611 Sugar Creek Road, Delavan, WI 53115, USA.

Applicable EU Harmonisation Legislation

EU / EC Declaration of Conformity in accordance with	EC Declaration of Incorporation In accordance with
<p>ATEX Directive – 2014/34/EU</p> <ul style="list-style-type: none"> Essential Health and Safety Requirement have been met by complying to the harmonised standard/s - EN 80079-36:2016, EN 80079-37:2016. Marking: II 2 G Ex h IIB T4 Gb or II 2 G Ex h IIB T2 Gb. Notified Body involved: Name: Bureau Veritas Italia S.p.A. Notified Body no.: 1370. Certification reference for: (i) Universal 2: BVI/ATEX/ITA/21/012 (ii) Universal 3: BVI/ATEX/ITA/21/013 	<p>Machinery Directive – 2006/42/EC For partly completed machinery</p> <ul style="list-style-type: none"> Essential Health and Safety Requirement for the relevant applicable clauses have been met by complying to harmonised standard/s - EN 12100:2010, EN 809:1998+AC:2010. <p>Note: Partly completed machinery must not be put into service until the final machinery into which it is incorporated has been declared in conformity with the Directive –2006/42/EC.</p>

This declaration of conformity is issued under the sole responsibility of the manufacturer. It will lose its validity if the product is modified without the written permission from the manufacturer and/or if the safety instructions specified in the instruction manual are not being followed.

Authorised Signatory:



Signature: _____ **Date:** 01//12/2021

Ashishkumar Lahoti, Engineering Manager.
 SPX FLOW, 611 Sugar Creek Road, Delavan, WI 53115, USA.

Universal 2 Maintenance Summary Reference Sheet

Universal 2 Model	Change oil every 750 hours* ISO Grade 320, SAE 140 or AGMA Number 6EP		Grease bearings every 750 hours* NLGI Grade No. 2, EP, Lithium-based grease.	
	* Aggressive washdown or extreme running conditions may require more frequent lubrication intervals.			
	Oil Capacity (Gears)		Grease Quantity (per Bearing)	
	Top or Bottom	Side Mount	Front	Rear
006, 014, 015, 018	1.3 oz (40 ml)	3.3 oz (100 ml)	0.37 oz (11 cc)	0.13 oz (4 cc)
030, 034, 040	2.0 oz (60 ml)	4 oz (120 ml)	0.60 oz (18 cc)	0.21 oz (6 cc)
045, 060, 064, 130, 134	6.0 oz (170 ml)	9.5 oz (280 ml)	0.84 oz (25 cc)	0.76 oz (22 cc)
180, 184, 220, 224	11 oz (320 ml)	20 oz (600 ml)	1.33 oz (39 cc)	1.03 oz (30 cc)
210, 213, 214, 320, 323, 324, 370	17 oz (500 ml)	44 oz (1300 ml)	1.96 oz (58 cc)	1.16 oz (34 cc)

Universal 2 Model	Torque Values - Locknuts		Universal 2 Wrench Size		
	Rotor	Cover	Rotor Nut	Body Retaining Cap Screw	Cover Nut
006, 014, 015, 018	50 ft lbs (68 N·m)	7 ft lbs (10 N·m)	15/16"	3/16"	5/8"
030, 034, 040	120 ft lbs (163 N·m)	11 ft lbs (15 N·m)	1-1/4"		5/8"
045, 060, 064	250 ft lbs (339 N·m)	56 ft lbs (76 N·m)	1-5/8"	1/4"	7/8"
130, 134		25 ft lbs (34 N·m)			
180, 184, 220, 224	325 ft lbs (441 N·m)	110 ft lbs (149 N·m)	2-1/4"	5/16"	7/8"
210, 213, 214, 320, 323, 324, 370	375 ft lbs (508 N·m)	158 ft lbs (214 N·m)	2-3/8"		1"

Universal 2 Model	A - Back Face in (mm)		B - Rotor to Body in (mm)		C - Front Face in (mm)	
	Std & FF	Hot	Std & FF	Hot	Standard	FF & Hot
006	0.0015 - 0.002 (0.04 - 0.05)	0.0015 - 0.002 (0.04 - 0.05)	0.001 - 0.004 (0.03 - 0.10)	0.0025 - 0.0055 (0.06 - 0.14)	0.004 - 0.006 (0.10 - 0.15)	0.0055 - 0.0075 (0.14 - 0.19)
014, 015, 018	0.0015 - 0.002 (0.04 - 0.05)	0.0015 - 0.002 (0.04 - 0.05)	0.001 - 0.004 (0.03 - 0.10)	0.0025 - 0.0055 (0.06 - 0.14)	0.004 - 0.0065 (0.10 - 0.17)	0.006 - 0.0085 (0.15 - 0.22)
030, 034, 040	0.002 - 0.0025 (0.05 - 0.06)	0.002 - 0.0025 (0.05 - 0.06)	0.001 - 0.005 (0.03 - 0.13)	0.0025 - 0.006 (0.06 - 0.15)	0.0035 - 0.006 (0.09 - 0.15)	0.0065 - 0.009 (0.17 - 0.23)
045, 060, 064	0.003 - 0.0035 (0.08 - 0.09)	0.003 - 0.0035 (0.08 - 0.09)	0.003 - 0.0075 (0.08 - 0.19)	0.005 - 0.010 (0.13 - 0.25)	0.0045 - 0.009 (0.11 - 0.23)	0.0085 - 0.014 (0.22 - 0.36)
130, 134	0.003 - 0.0035 (0.08 - 0.09)	0.003 - 0.0035 (0.08 - 0.09)	0.0035 - 0.0075 (0.09 - 0.19)	0.0055 - 0.0095 (0.14 - 0.24)	0.0045 - 0.009 (0.11 - 0.23)	0.009 - 0.015 (0.23 - 0.38)
180, 184, 220, 224	0.004 - 0.005 (0.10 - 0.13)	0.004 - 0.005 (0.10 - 0.13)	0.0055 - 0.0095 (0.14 - 0.24)	0.009 - 0.013 (0.23 - 0.33)	0.005 - 0.010 (0.13 - 0.25)	0.010 - 0.015 (0.25 - 0.38)
210, 213, 214, 320, 323, 324	0.005 - 0.006 (0.13 - 0.15)	0.005 - 0.006 (0.13 - 0.15)	0.008 - 0.012 (0.20 - 0.30)	0.010 - 0.014 (0.25 - 0.36)	0.007 - 0.012 (0.18 - 0.30)	0.013 - 0.018 (0.33 - 0.46)
370	0.005 - 0.006 (0.13 - 0.15)	0.005 - 0.006 (0.13 - 0.15)	0.009 - 0.013 (0.23 - 0.33)	0.011 - 0.015 (0.28 - 0.38)	0.007 - 0.012 (0.18 - 0.30)	0.013 - 0.018 (0.33 - 0.46)

Std = Standard Clearance Rotors; FF = Front Faced Clearance Rotors; Hot = Hot Clearance Rotors

Standard Rotors: -40°F (-40°C) to 180°F (82°C); FF Clearance Rotors: 180°F (82°C) to 200°F (93°C); Hot Clearance Rotors: -40°F (-40°C) to 300°F (149°C). Contact SPX FLOW Application Engineering if alternate rotors are needed. *NOTE: The assembly clearances stated above are for reference only. Actual pump clearances may vary based on pump performance testing.*

Universal 2 Maintenance Summary Reference Sheet - Copy for optional removal

Universal 2 Model	Change oil every 750 hours* ISO Grade 320, SAE 140 or AGMA Number 6EP		Grease bearings every 750 hours* NLGI Grade No. 2, EP, Lithium-based grease.	
	<i>* Aggressive washdown or extreme running conditions may require more frequent lubrication intervals.</i>			
	Oil Capacity (Gears)		Grease Quantity (per Bearing)	
	Top or Bottom	Side Mount	Front	Rear
006, 014, 015, 018	1.3 oz (40 ml)	3.3 oz (100 ml)	0.37 oz (11 cc)	0.13 oz (4 cc)
030, 034, 040	2.0 oz (60 ml)	4 oz (120 ml)	0.60 oz (18 cc)	0.21 oz (6 cc)
045, 060, 064, 130, 134	6.0 oz (170 ml)	9.5 oz (280 ml)	0.84 oz (25 cc)	0.76 oz (22 cc)
180, 184, 220, 224	11 oz (320 ml)	20 oz (600 ml)	1.33 oz (39 cc)	1.03 oz (30 cc)
210, 213, 214, 320, 323, 324, 370	17 oz (500 ml)	44 oz (1300 ml)	1.96 oz (58 cc)	1.16 oz (34 cc)

Universal 2 Model	Torque Values - Locknuts		Universal 2 Wrench Size		
	Rotor	Cover	Rotor Nut	Body Retaining Cap Screw	Cover Nut
006, 014, 015, 018	50 ft lbs (68 N·m)	7 ft lbs (10 N·m)	15/16"	3/16"	5/8"
030, 034, 040	120 ft lbs (163 N·m)	11 ft lbs (15 N·m)	1-1/4"		5/8"
045, 060, 064 130, 134	250 ft lbs (339 N·m)	56 ft lbs (76 N·m)	1-5/8"	1/4"	7/8"
		25 ft lbs (34 N·m)			
180, 184, 220, 224	325 ft lbs (441 N·m)	110 ft lbs (149 N·m)	2-1/4"	5/16"	7/8"
210, 213, 214 320, 323, 324, 370	375 ft lbs (508 N·m)	158 ft lbs (214 N·m)	2-3/8"		1"

Universal 2 Model	A - Back Face in (mm)		B - Rotor to Body in (mm)		C - Front Face in (mm)	
	Std & FF	Hot	Std & FF	Hot	Standard	FF & Hot
006	0.0015 - 0.002 (0.04 - 0.05)	0.0015 - 0.002 (0.04 - 0.05)	0.001 - 0.004 (0.03 - 0.10)	0.0025 - 0.0055 (0.06 - 0.14)	0.004 - 0.006 (0.10 - 0.15)	0.0055 - 0.0075 (0.14 - 0.19)
014, 015, 018	0.0015 - 0.002 (0.04 - 0.05)	0.0015 - 0.002 (0.04 - 0.05)	0.001 - 0.004 (0.03 - 0.10)	0.0025 - 0.0055 (0.06 - 0.14)	0.004 - 0.0065 (0.10 - 0.17)	0.006 - 0.0085 (0.15 - 0.22)
030, 034, 040	0.002 - 0.0025 (0.05 - 0.06)	0.002 - 0.0025 (0.05 - 0.06)	0.001 - 0.005 (0.03 - 0.13)	0.0025 - 0.006 (0.06 - 0.15)	0.0035 - 0.006 (0.09 - 0.15)	0.0065 - 0.009 (0.17 - 0.23)
045, 060, 064	0.003 - 0.0035 (0.08 - 0.09)	0.003 - 0.0035 (0.08 - 0.09)	0.003 - 0.0075 (0.08 - 0.19)	0.005 - 0.010 (0.13 - 0.25)	0.0045 - 0.009 (0.11 - 0.23)	0.0085 - 0.014 (0.22 - 0.36)
130, 134	0.003 - 0.0035 (0.08 - 0.09)	0.003 - 0.0035 (0.08 - 0.09)	0.0035 - 0.0075 (0.09 - 0.19)	0.0055 - 0.0095 (0.14 - 0.24)	0.0045 - 0.009 (0.11 - 0.23)	0.009 - 0.015 (0.23 - 0.38)
180, 184, 220, 224	0.004 - 0.005 (0.10 - 0.13)	0.004 - 0.005 (0.10 - 0.13)	0.0055 - 0.0095 (0.14 - 0.24)	0.009 - 0.013 (0.23 - 0.33)	0.005 - 0.010 (0.13 - 0.25)	0.010 - 0.015 (0.25 - 0.38)
210, 213, 214, 320, 323, 324	0.005 - 0.006 (0.13 - 0.15)	0.005 - 0.006 (0.13 - 0.15)	0.008 - 0.012 (0.20 - 0.30)	0.010 - 0.014 (0.25 - 0.36)	0.007 - 0.012 (0.18 - 0.30)	0.013 - 0.018 (0.33 - 0.46)
370	0.005 - 0.006 (0.13 - 0.15)	0.005 - 0.006 (0.13 - 0.15)	0.009 - 0.013 (0.23 - 0.33)	0.011 - 0.015 (0.28 - 0.38)	0.007 - 0.012 (0.18 - 0.30)	0.013 - 0.018 (0.33 - 0.46)

Std = Standard Clearance Rotors; FF = Front Faced Clearance Rotors; Hot = Hot Clearance Rotors

Standard Rotors: -40°F (-40°C) to 180°F (82°C); FF Clearance Rotors: 180°F (82°C) to 200°F (93°C); Hot Clearance Rotors: -40°F (-40°C) to 300°F (149°C). Contact SPX FLOW Application Engineering if alternate rotors are needed. *NOTE: The assembly clearances stated above are for reference only. Actual pump clearances may vary based on pump performance testing.*

Notes



› Waukesha Cherry-Burrell®



Universal 2 Series

Rotary Positive Displacement Pump

SPXFLOW®

611 Sugar creek Road
Delavan, WI 53115
U.S.A.

P: (262) 728-1900 or (800) 252-5200
F: (262) 728-4904 or (800) 252-5012
E: wcb@spxflow.com

www.spxflow.com/hankison

Improvements and research are
continuous at SPX FLOW, Inc.
Specifications may change without
notice.

ISSUED 07/2024
Form No.: 95-03015

Copyright ©2022 SPX FLOW, Inc.