

1) Manufacturer's Declaration

2) General Safety Guidelines

3) Technical Data and Functional Description

4) Parts and Spare Parts List

5) Installation Instructions

6) Dismantling

7) Maintenance

8) Assembly

1) Manufacturer's Declaration

We hereby declare that shutter- and pig diverter valves are 'partly completed machines' according to Article 2g of the EC Machinery Directive 2006/42.

2) General Safety Guidelines

- a) Working on the valve is principally allowed only in depressurized and cooled condition
- b) Observe the following when demounting the valve from the piping system:
 - Potential risk of injury from escaping liquid or gas
 - Remove the control line prior to any assembly activity on pneumatic valves
 - Do not put your hand/fingers into the valve casing; hazard of crush or severance of limbs
- c) **Do not** operate the valve under dry conditions



3) Technical Data

Nominal sizes:

- Shutter valves: Inch 1"–6" / DIN DN25 – DN150
- Pig diverter valves: Inch 1.5" - 4" / DIN DN40 - DN100

Versions:

- Shutter valves: 2- / 3- / 4-way (upon request):
- Pig diverter valves: 3-way (3 x 120°)
- Manual
- Pneumatic or electric actuation with interface per Namur NE14 and DIN EN ISO5211 (F05 / F07)

Materials:

- Inox parts in contact with product: AISI 316L (1.4404 / 1.4435)
- Other Inox parts: AISI 304 (1.4301)
- O-ring seals:

| | Temperature | Short-term temp. |
|-------------------------|------------------------------------|------------------|
| EPDM (Standard) | -40°F to +230°F -40°C to +110°C | +284°F +140°C |
| FPM (Viton®) (optional) | -4°F to +320°F -20°C to +160°C | +356°F +180°C |
| FEP (optional) | -76°F to +392°F -60°C to +200°C | +446°F +230°C |

• Shutter:

| | Temperature | Pressure max (see Figure 8). | |
|---------------------------|-----------------|------------------------------|-----------------|
| | | Prod. flow direction | Against shutter |
| PTFE TFM1600 (Standard) | -76°F to +230°F | 145 psi | 43.5 psi |
| | -60°C to +110°C | 10 bar | 3 bar |
| PTFE +15% Peek (optional) | -76°F to +320°F | 232 psi | 43.5 psi |
| | -60°C to +160°C | 16 bar | 3 bar |
| Tecapeek (optional) | -76°F to +392°F | 290 psi | 43.5 psi |
| | -60°C to +200°C | 20 bar | 3 bar |

• Bearing bushing:

| | Temperature | Short-term temp. |
|----------------|------------------------------------|------------------|
| POM (Standard) | -58°F to +230°F -50°C to +110°C | +284°F +140°C |
| PTFE TFM1600 | -76°F to +392°F -60°C to +200°C | +446°F +230°C |

Surfaces:

In contact with product: Ra ≤ 32µin (Ra ≤ 0.8µm)

Valve connections:

Welded ends: Inch, DIN
Male ends: DIN11851, SMS1145
Clamp connection: Tri-Clamp

Functional Description

A radially rotatable shutter permits various positions of shutter- and pig diverter valves. Integrated in a piping system, the 2-way shutter valve acts as a on/off valve and the 3-way shutter valve as a manifold valve.

The outlets of the pig diverter valve are orientated in a 120° angle, which allows the pig to pass the valves in all directions.

Optical position indication of the shutter:

- With the manual 2-way shutter valve, the parallel position of the handle to the valve ports indicates that the valve is open for product flow; the marking (S) on the handle base indicates the shutter position (see Figure 1)
- With the manual 3-way shutter / pig diverter valve, the handle direction indicates the shutter position (see Figure 3 and Figure 5)
- With the pneumatic shutter / pig diverter valve, an optical position indication in the form of a red arrow on the square of the pivoted axle, indicates the current shutter position (see Figures 2 / 4 and 6)

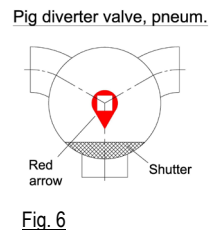
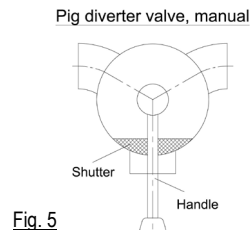
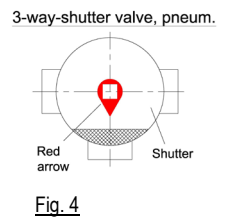
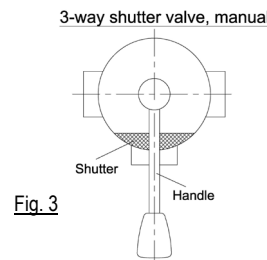
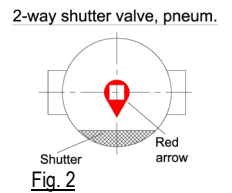
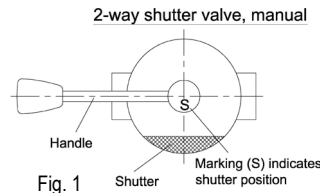

4) Parts and Spare Parts List

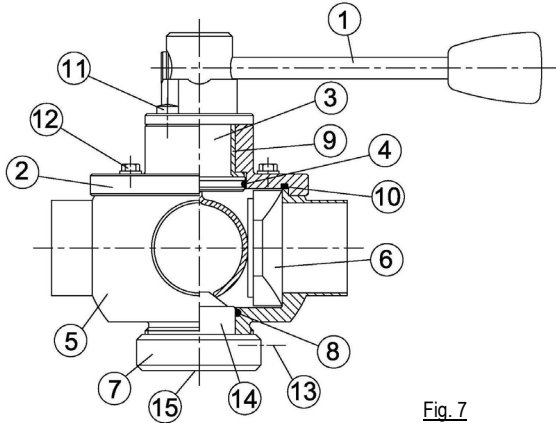

Fig. 7

Parts and Spare Parts List (spares in bold and italic type):

| Item | Designation | Qty. |
|------|------------------------------------|----------|
| 1 | Handle or pneumatic actuator | 1 |
| 2 | Bearing cap | 1 |
| 3 | Pivoted axle with arc | 1 |
| 4 | O-ring to the pivoted axle | 1 |
| 5 | Valve casing | 1 |
| 6 | Shutter | 1 |
| 7 | Pinch nut | 1 |
| 8 | O-ring to the cone | 1 |
| 9 | Bearing bushing | 1 |
| 10 | O-ring to the bearing cap | 1 |
| 11 | Fixing screw for handle (actuator) | 2 |
| 12 | Fixing screws for bearing cap | 4 |
| 13 | Allen screw | 1 |
| 14 | Cone | 1 |
| 15 | Snap ring | 1 |

5) Installation Instructions

- The shutter / pig diverter valve is suitable for any installation position
- For self drainage the valve outlet has to point downward**
- In order to avoid damage, the shutter / pig diverter valve has to be dismantled before being welded in place in a piping system**
- Recommended installation (see Figure 8)

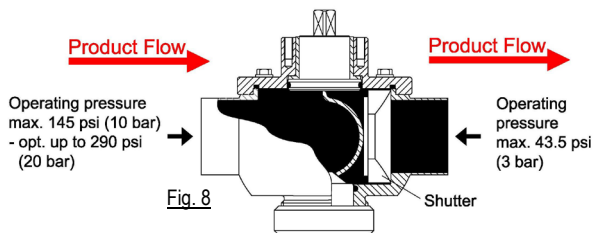

Fig. 8

6) Dismantling

- Never demount a pressurized shutter / pig diverter valve.**
- Loosen the fixing screws (11) on the handle to remove the handle (1).
- Loosen the allen screw (13) on the pinch nut (7) which is connected to the cone (14) by a snap ring (15).
- Use a face pin spanner wrench to loosen the pinch nut (7).
- Loosen the fixing screws (12) to remove the bearing cap (2) incl. pivoted axle (3) and bearing bushing (9).
- Remove the shutter (6) from the valve casing (5).
- Pull out the pivoted axle (3) from the bearing cap (2).
- Take out all O-rings.



7) Maintenance



- Check functional surfaces in the valve casing (5) for their condition and clean them accurate.
- Replace all O-rings: O-ring to the pivoted axle (4), O-ring to the cone (8), O-ring to the bearing cap (10).
- Prior to assembly, lubricate O-rings with food-safe grease "Klüber Paraliq GTE 703".
- Check proper working order of the bearing bushing (9) and replace as necessary.
- Clean shutter (6) and check for proper working and wear; replace as necessary.

Lubricants

- For shutter / pig diverter valve O-ring seals in contact with product (EPDM / FPM / FEP):
 - Klüber Paraliq GTE 703 NFS H1
- For Inox screws DIN912 and DIN933:
 - Klüber lubricating paste UH1 84-201

Recommendation for cleaning (CIP)

Optimal cleaning results will be accomplished with switching of the shutter / pig diverter valve while flushing (CIP).

8) Assembly

- Check all components for cleanliness and proper condition prior to shutter / pig diverter valve assembly.
- Insert bearing bushing (9) into bearing cap (2).
- Insert O-rings (4), (8) and (10).
- Assemble pivoted axle with arc (3) and bearing cap (2). Pay attention to the marking (0) on the square pin of the pivoted axle (3) → indicates the shutter position (6) (see Figure 9).
- Insert shutter (6) into valve casing (5).
- Fit the pivoted axle with the arc (3) together with bearing cap (2) to the valve casing (5) as follows:
 - The pivoted axle with arc (3) is designed that it exerts a defined pressure on the shutter (6) during assembly. On account of the preload characteristics, the bearing cap (2) declines approx. 0.16-0.20in (4-5mm) off the valve casing (5) on the opposite side of the shutter (see Figure 9).
 - The shutter should be positioned to the inner casing wall to prestress damages on the plastic surface.**
 - Fasten the handle (1) in the desired position.

Note:
For shutter / pig diverter valves with pneumatic actuator proceed as follows: before assembly of the actuator, turn the square pin of the pivoted axle (3) into the desired shutter position by means of a jaw spanner and the marking (0).

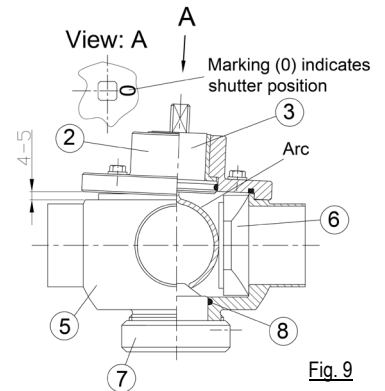

Fig. 9

- Put in place and tighten the bearing cap fixing screws (12).
- Assemble the pinch nut (7) to the valve casing (5) by using a face pin spanner and a torque wrench: Torque 4Nm
Alternative: Screw pinch nut (7) by hand (without a tool) into the valve casing (5), just past the o-ring (8). Switch valve several times (~5x), then slightly tighten the pinch nut 90° more by hand or with face spanner.
- Secure pinch nut (7) with allen screw (13).