



# Alfa Laval Unique SSV Pressure Relief Valve

## Single seat valves

### Introduction

Protect your hygienic processing lines—especially those with positive displacement pumps—with the Alfa Laval Unique SSV Pressure Relief Valve. Preventing overpressure safeguards efficiency, productivity and product safety. Customize this compact, modular valve, built on the proven Unique SSV platform, to meet your requirements. Equip this overflow valve with Alfa Laval ThinkTop technology for valve monitoring and control, while safeguarding process efficiency, productivity and safety.

### Application

The Unique SSV Pressure Relief Valve is designed for use in a broad range of hygienic applications across the dairy, food, beverage and many other industries.

### Benefits

Reliable pressure relief valve for your hygienic processing lines

- Keeps pressure within safe operating limits
- Ensures reliable performance with flexible, on-site setup
- Enhances efficiency and product safety through validated cleaning
- Ensures compliance with hygienic or aseptic process requirements
- Enables easy settings adjustment for precise pressure control and process safety

Safeguard your hygienic equipment from overpressure with the Alfa Laval Unique SSV Pressure Relief Valve. This adjustable PRV provides precise pressure control to maximize uptime, even in dynamic environments, making it ideal for the dairy, food, beverage, and home and personal care industries.

When powered by Alfa Laval ThinkTop technology, it proactively detects issues, ensures process and product safety, and seamlessly adapts to various operating conditions. It is fully CIP-able, no matter the pressure setting. Spare parts are interchangeable with other Unique SSV valves, simplifying maintenance and reducing service time, inventory and administration costs.

Boost efficiency while safeguarding your processing lines with the Unique SSV Pressure Relief Valve.

### Standard Design

The Unique SSV Pressure Relief Valve is available in a one- or two-body configuration, and it is easy-to-configure the valve



to match a specific need. The valve can be configured in a direct or reverse acting function shutoff valve or as a changeover valve, but also in aseptic and tangential configurations for maximum flexibility.

The valve seals are optimized for durability and long service life through a defined compression design. The actuator is connected to the valve body using a yoke, and all components are assembled with clamp rings. The valve can also be fitted with the power of Alfa Laval ThinkTop for sensing and control of the valve. Using the Alfa Laval Anytime configurator, it is easy to customize to meet many different process requirements.

### Working Principle

The Alfa Laval Unique SSV Pressure Relief Valve ensures system integrity by preventing overpressure in hygienic processing lines. Easily adjust the set pressure on site using the actuator's adjustment screw to match your desired

settings, which are always higher than the operating pressure, to safeguard critical equipment like positive displacement pumps.

When the operating pressure exceeds the set threshold, the valve opens against spring force, venting pressure and protecting your equipment, system and process from potential damage.

Fit the valve with Alfa Laval ThinkTop technology to monitor and control valve positions, enabling early issue detection, preventing failures and minimizing downtime. During cleaning-in-place (CIP), the valve opens fully—regardless of the set pressure—ensuring maximum hygiene and industry standards compliance.

## Technical Data

### Temperature / Pressure

Valve	
Temperature range:	-10 °C to +140 °C / 14 °F to + 284 °F (EPDM)
Max. product pressure:	1000 kPa / 10 bar / 145 psi
Min. product pressure:	Full vacuum (depending on product specifications)

### Actuator

Temperature range:	-10 °C to +60 °C / 14 °F to + 140 °F
Air pressure:	500-700 kPa / 5-7 bar / 72.5-101.5 psi

### Valve body combinations

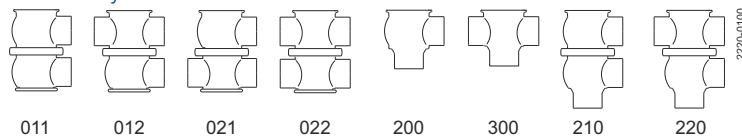

### Actuator function

- Pneumatic downward movement, spring return
- Pneumatic upward movement, spring return

## Physical Data

Materials	
Product wetted steel parts	1.4404 (316L)
Non-product wetted steel parts	1.4301 (304)
Product wetted seals	EPDM
Alternative product wetted seals	NBR, HNBR and FPM
External surface finish	Bead blasted
Internal surface finish	Bright (polished), Ra < 0.8 µm (< 32 µin)

## Options

- Male parts or clamp liners in accordance with required standard
- Control and Indication: ThinkTop
- Plug seals EPDM, HNBR or FPM
- Maintainable actuator

### Other valves in the same basic design

The Unique SSV valve range includes several purpose built valves. Below are some of the valve models available, though please use the Alfa Laval Anytime configurator for full access to all models and options like Aseptic or Tangential.

## Dimensions

### Reverse acting Shut-off valve

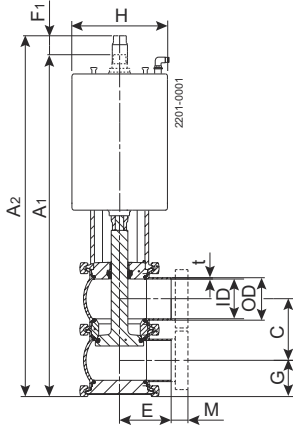

### Direct acting Shut-off valve

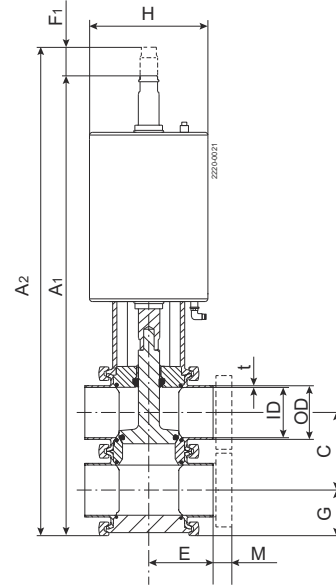

mm

Nominal size	Inch tubes DN/OD						DIN tubes DN					
	25	38	51	63.5	76.1	101.6	25	40	50	65	80	100
A <sub>1</sub>	369	386	411	486	538	532	377	392	416	498	555	538
A <sub>2</sub>	381	398	423	501	553	547	389	404	428	513	570	553
C	47.8	60.8	73.8	86.3	98.9	123.6	52	64	76	92	107	126
OD	25	38	51	63.5	76.1	101.6	29	41	53	70	85	104
ID	21.8	34.8	47.8	60.3	72.9	97.6	26	38	50	66	81	100
L	1.6	1.6	1.6	1.6	1.6	2	1.5	1.5	1.5	2	2	2
E	50	49.5	61	81	86	119	50	49.5	62	78	87	120
F <sub>1</sub>	12	12	12	15	15	15	12	12	12	15	15	15
G	23.9	30.4	40.5	43.15	49.45	62	26	32	38	46	53.5	63
H	Ø115	Ø115	Ø115	Ø157	Ø157	Ø157	Ø115	Ø115	Ø115	Ø157	Ø157	Ø157
M (ISO clamp)	21	21	21	21	21	21						
M (DIN clamp)							21	21	21	28	28	28
M (DIN male)							22	22	23	25	25	30
M (SMS male)	20	20	20	24	24	24						

inch

Nominal size	Inch tubes DN/OD					
	1"	1½"	2"	2½"	3"	4"
A <sub>1</sub>	14.53	15.2	16.18	19.13	21.18	20.94
A <sub>2</sub>	15	15.67	16.65	19.72	21.77	21.54
C	1.88	2.39	2.91	3.4	3.89	4.87
OD	0.98	1.5	2.01	2.5	3	4
ID	0.86	1.37	1.88	2.37	2.87	3.84
L	0.06	0.06	0.06	0.06	0.06	0.08
E	1.97	1.95	2.4	3.19	3.39	4.69
F <sub>1</sub>	0.47	0.47	0.47	0.59	0.59	0.59
G	0.94	1.2	1.59	1.7	1.95	2.44
H	Ø4.53	Ø4.53	Ø4.53	Ø6.18	Ø6.18	Ø6.18
M (ISO clamp)	0.83	0.83	0.83	0.83	0.83	0.83
M (SMS male)	0.79	0.79	0.79	0.94	0.94	0.94



#### Please note!

#### Opening/closing time will be effected by the following:

- The air supply (air pressure).
- The length and dimensions of the air hoses.
- Number of valves connected to the same air hose.
- Use of single solenoid valve for serial connected air actuator functions.
- Product pressure.

## Air Connections Compressed air

R 1/8" (BSP), internal thread.

Air consumption (litres free air) for one stroke [bar]

Size	DN25-50 / DN/OD 25-51 mm	DN65-100 / DN/OD 63.5-101.6 mm
NO and NC	0.5 x air pressure [bar]	1.3 x air pressure [bar]

Air consumption (litres free air) for one stroke [psi]

Size	1"-2"	2½"-4"
NO and NC	0.5 x air pressure [psi]	1.3 x air pressure [psi]

## Weight

(kg)

Nominal size	Inch tubes - DN/OD						DIN tubes - DN					
	25	38	51	63.5	76.1	101.6	25	40	50	65	80	100
Shut-off valve, config 200:	4.3	5.3	5.9	11	12	13.3	4.4	5.4	6	11.1	12.1	13.4

(lb)

Nominal size	1"	1½"	2"	2½"	3"	4"
Shut-off valve, config 200:	9.48	11.68	13.01	24.25	26.46	29.32

## Pressure drop/capacity diagrams

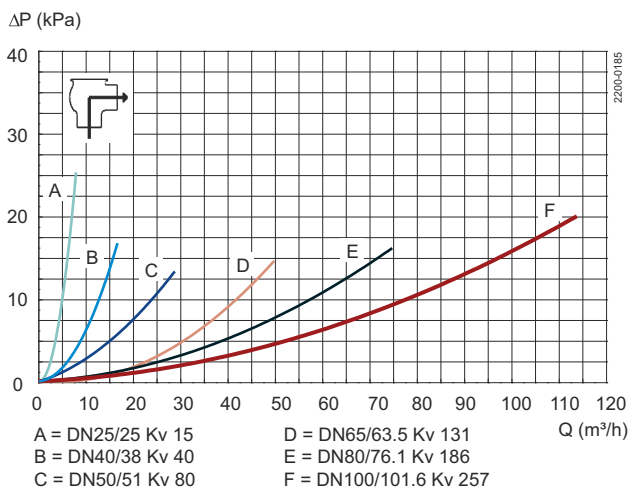
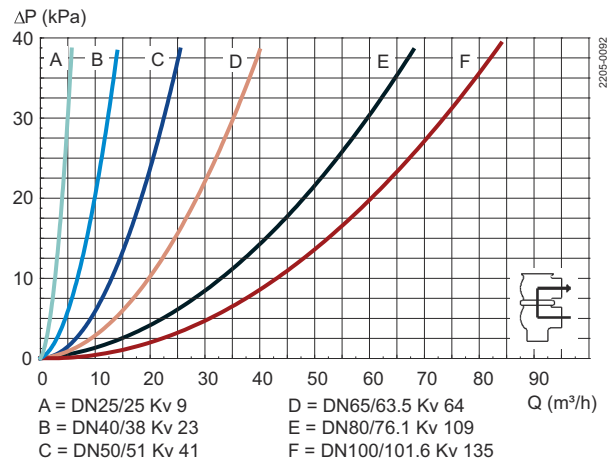
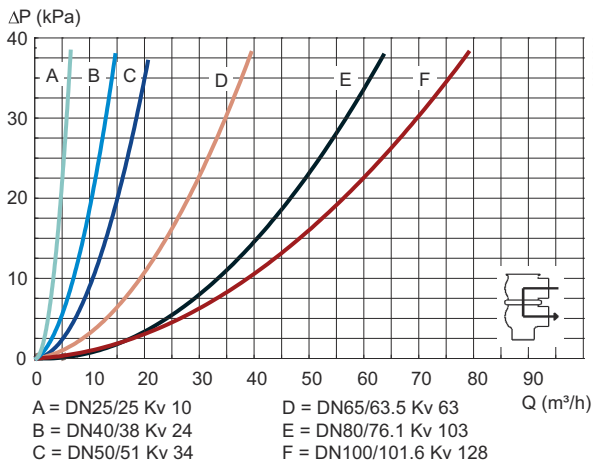

### Note!

For the diagrams the following applies:

Medium: Water (20 °C / 68 °F)

Measurement: In accordance with VDI2173

Pressure drop can also be calculated in Anytime configurator.

Pressure drop can also be calculated with the following formula:

$$Q = K_v \times \sqrt{\Delta p}$$

Where

Q = Flow in m<sup>3</sup>/h. (gallon/minute)

K<sub>v</sub> = m<sup>3</sup>/h (gallon/minute) at a pressure drop of 1 bar (1 psi) (see table above).

Δ p = Pressure drop in bar over the valve.

How to calculate the pressure drop for an ISO 2.5" shut-off valve if the flow is 40 m<sup>3</sup>/h (160 gallon/minute.)

2.5" shut-off valve, where K<sub>v</sub> = 111 (128) (See table above).

$$40 = 111 \times \sqrt{\Delta p}$$

$$\Delta p = \left(\frac{40}{111}\right)^2 = 0.13 \text{ bar}$$

$$160 = 128 \times \sqrt{\Delta p}$$

$$\Delta p = \left(\frac{160}{128}\right)^2 = 1.6 \text{ psi}$$

(This is approx. the same pressure drop by reading the y-axis above)

### Adjustment range for relief pressure

NC:

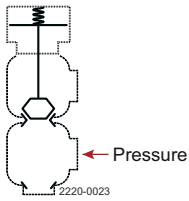

NO:

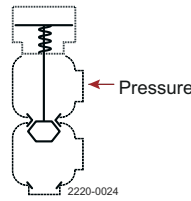

	25 mm / DN25 / 1"	38 mm / DN40 / 1½"	51 mm / DN50 / 2"	63.5 mm / DN65 / 2½"	76.1 mm / DN80 / 3"	101.6 mm / DN100 / 4"
NC	0-10 bar / 0-145 psi	0-10 bar / 0-145 psi	0-10 bar / 0-145 psi	0-10 bar / 0-145 psi	0-10 bar / 0-145 psi	0-8 bar / 0-116 psi
NO	≤ 1.5-10 bar / ≤ 21.8-145 psi	≤ 1.5-10 bar / ≤ 21.8-145 psi	≤ 1.5-10 bar / ≤ 21.8-145 psi	≤ 1.5-10 bar / ≤ 21.8-145 psi	≤ 1.5-10 bar / ≤ 21.8-145 psi	≤ 1.5-8 bar / ≤ 21.8-116 psi

This document and its contents are subject to copyrights and other intellectual property rights owned by Alfa Laval AB (publ) or any of its affiliates (jointly "Alfa Laval"). No part of this document may be copied, re-produced or transmitted in any form or by any means, or for any purpose, without Alfa Laval's prior express written permission. Information and services provided in this document are made as a benefit and service to the user, and no representations or warranties are made about the accuracy or suitability of this information and these services for any purpose. All rights are reserved.