



Alfa Laval Unique SSV Two Step

Single seat valves

Introduction

The Alfa Laval Unique SSV Two Step is a versatile, reliable pneumatic single seat valve with a single contact surface between the plug and the seat to minimize the risk of contamination. Its compact, modular and hygienic design meets the highest process demands in terms of hygiene and safety.

Built on the well-proven Alfa Laval Unique SSV platform, it is ideal for dosing and two-stage filling to ensure an exact volume or for draining of two pipes at the same time while reducing the risk of pressure shocks. Adjustable lifting height makes it possible to match specific volumes and quantities.

Few moving parts ensure easy dismantling, high reliability and low maintenance costs. A wide range of optional features enables customization to specific process requirements.

Application

The Unique SSV Two Step is designed for dosing and filling in a broad range of hygienic applications across the dairy, food, beverage, brewery and many other industries.

Benefits

- Exceptional valve hygiene and durability
- Superior cleanability – smooth inner valve body without crevices
- Extended seal life due to defined seal compression
- Enhances product safety due to static seal leak detection
- Protection against full vacuum due to double lip seal
- Intermediate plug position

Standard design

The Unique SSV Two Step is available in a one- or two-body configuration, with easy-to-configure valve bodies, plugs, actuator and clamp rings. The valve can be configured as a shutoff valve with two to three working ports, or as a changeover valve with up to five ports for drainage of two pipes simultaneously or in closing/filling applications.

To ensure flexibility, the valve seat that sits between the two bodies in the changeover version is provided for assembly. The valve seals are optimized for durability and long service life through a defined compression design. The actuator is



connected to the valve body using a yoke, and all components are assembled with clamp rings. The degree of opening for the intermediate position can be adjusted by removing spacer rings inside the actuator.

The valve can also be fitted with the Alfa Laval ThinkTop V50 and V70 for sensing and control of the valve.

Using the Alfa Laval Anytime configurator, it is easy to customize to meet virtually any process requirement.

Working principle

The Alfa Laval Unique SSV Two Step is operated by means of compressed air from a remote location. The actuator smooths operation and an intermediate step protects process lines from pressure peaks while dosing and filling. The valve can be controlled using an Alfa Laval ThinkTop®.

Certificates

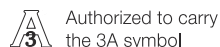

Authorized to carry the 3A symbol

TECHNICAL DATA

| Temperature | |
|-------------------|-----------------------|
| Temperature range | 14°F to +284°F (EPDM) |

| Pressure | |
|--|--------------------------------|
| Max. product pressure (depending on valve specifications): | 145 psi (1000 kPa (10 bar)) |
| Min. product pressure: | Full vacuum |
| Air pressure: | 72.5 to 101.5 psi (5 to 7 bar) |

Valve Body Combinations

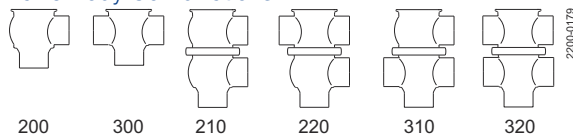

Actuator function

- Pneumatic downward movement, spring return.
- Pneumatic upward movement, spring return.

PHYSICAL DATA

| Materials | |
|--------------------------------|------------------------------------|
| Product wetted steel parts: | AISI 316L (internal Ra < 32 µinch) |
| Other steel parts: | AISI 304 |
| Plug seal: | PTFE (TR2) (standard) |
| Optional plug seal: | EPDM, HNBR or FPM |
| Other product wetted seals: | EPDM (standard) |
| Optional product wetted seals: | HNBR and FPM |
| Other seals: | NBR |

Options

- Weld ends or connection types other than Tri-Clamp.
- Control and Indication: IndiTop, ThinkTop or ThinkTop Basic.
- Product wetted seals in HNBR or FPM.
- Replaceable elastomer plug seals.
- High pressure actuator (only 1.5" - 2.5").
- External surface finish blasted.



Note!

For further details, see instruction ESE00505.

Other valves in the same basic design

The valve range includes several purpose built valves. Below are some of the valve models available, though please use the Alfa Laval Anytime configurator for full access to all models and options.

- Aseptic valve.

Semi-Maintainable actuator comes with 5 year warranty.

Dimensions (inch)

| Nominal size | Inch tubes DN/OD | | | | | High Pressure | |
|----------------|---------------------|-------|-------|-------|-------|---------------|-------|
| | 1.5" | 2" | 2.5" | 3" | 4" | 2" | 2.5" |
| A ₁ | 15.06 | 15.57 | 16.60 | 18.04 | 19.83 | 16.76 | 17.79 |
| A ₂ | 15.84 | 16.6 | 17.58 | 19.2 | 21.01 | 17.74 | 18.78 |
| A ₃ | 17.4 | 18.47 | 20.00 | 21.94 | 24.69 | 19.67 | 21.19 |
| A ₄ | 18.12 | 19.34 | 20.86 | 23.00 | 25.76 | 20.53 | 22.06 |
| C | 2.39 | 2.91 | 3.4 | 3.89 | 4.87 | 2.91 | 3.4 |
| OD | 1.5 | 2.01 | 2.5 | 3 | 4 | 2.01 | 2.5 |
| ID | 1.37 | 1.88 | 2.37 | 2.87 | 3.84 | 1.88 | 2.37 |
| t | 0.06 | 0.06 | 0.06 | 0.06 | 0.08 | 0.06 | 0.06 |
| E | 1.95 | 2.40 | 3.19 | 3.39 | 4.69 | 2.40 | 3.19 |

| Nominal size | Inch tubes DN/OD | | | | | High Pressure | |
|-------------------------------------|---------------------|-------|-------|-------|-------|---------------|-------|
| | 1.5" | 2" | 2.5" | 3" | 4" | 2" | 2.5" |
| F ₁ | 0.79 | 0.98 | 0.98 | 1.18 | 1.18 | 0.98 | 0.98 |
| F ₂ Min. Two step stroke | 0.12 | 0.12 | 0.12 | 0.10 | 0.10 | 0.24 | 0.24 |
| F ₃ Max. Two step stroke | 0.24 | 0.43 | 0.43 | 0.55 | 0.55 | 0.35 | 0.35 |
| F ₄ | 0.67 | 0.87 | 0.87 | 1.06 | 1.06 | 0.87 | 0.87 |
| F ₅ Two step stroke | 0.26 | 0.43 | 0.43 | 0.55 | 0.55 | 0.35 | 0.35 |
| H | 4.53 | 4.53 | 4.53 | 6.06 | 6.06 | 6.06 | 6.06 |
| M (clamp) | 0.5 | 0.5 | 0.5 | 0.5 | 0.63 | 0.5 | 0.5 |
| Weight (lb) | | | | | | | |
| Stop valve | 15.43 | 16.09 | 18.30 | 31.75 | 36.82 | 18.96 | 21.16 |
| Change-over valve | 17.64 | 19.62 | 22.71 | 37.48 | 46.30 | 22.49 | 25.57 |

Air Connections: R 1/8" (BSP), internal thread.

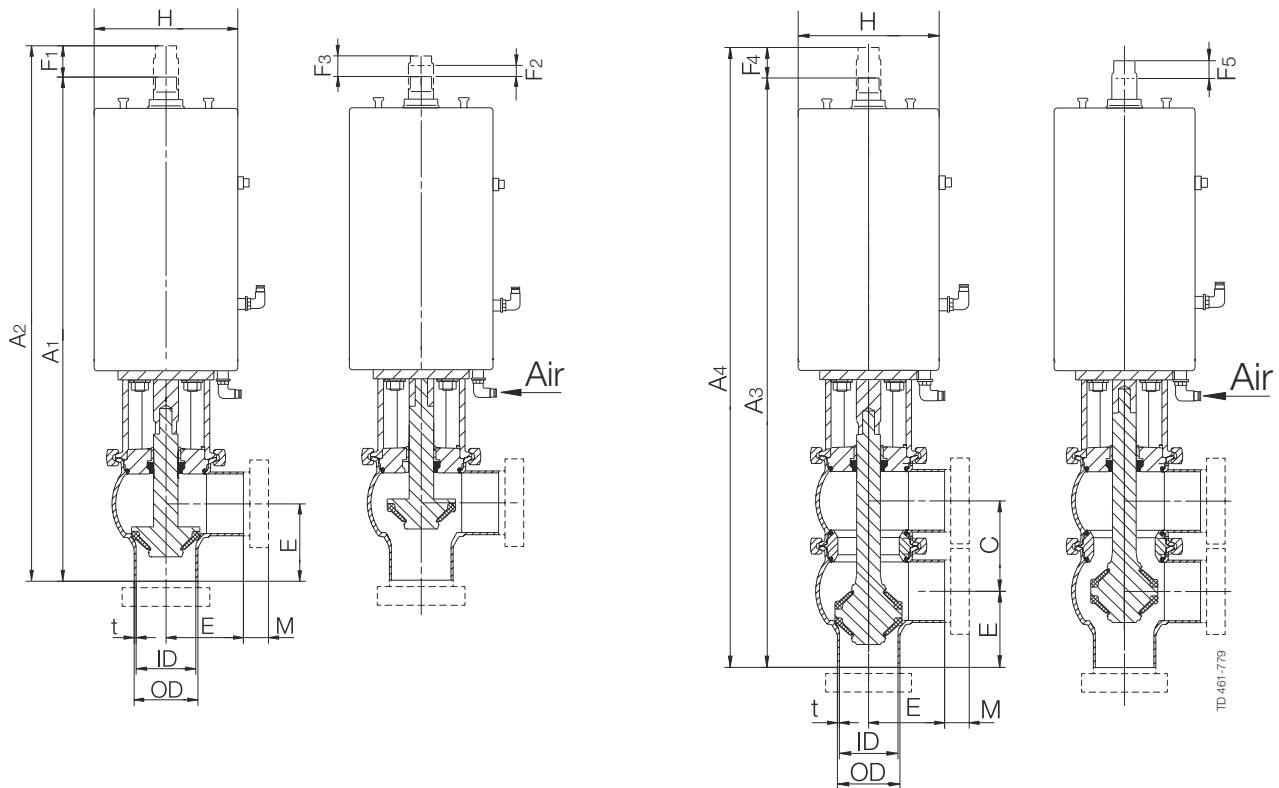

Shut-off valve closed

Shut-off valve with
two step stroke activated

Change-over valve closed

Change-over valve with
two step stroke activated

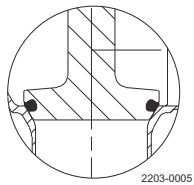

Figure 1. Replaceable elastomer plug seal

| | Air Consumption (In ³ free air) for one stroke | | |
|-----------|---|---------------------------|---------------------------|
| Size | 1.5" | 2 - 2.5" | 3" - 4" |
| NO and NC | 2.17 x air pressure [psi] | 2.17 x air pressure [psi] | 5.51 x air pressure [psi] |



Note!

Vacuum is not recommended in aseptic applications.

Opening/closing time will be affected by the following:

- The air supply (air pressure).
- The length and dimensions of the air hoses.
- The number of valves connected to the same air hose.
- Use of a single solenoid valve for serial connected air actuator functions.
- Product pressure.

Pressure drop/capacity diagrams

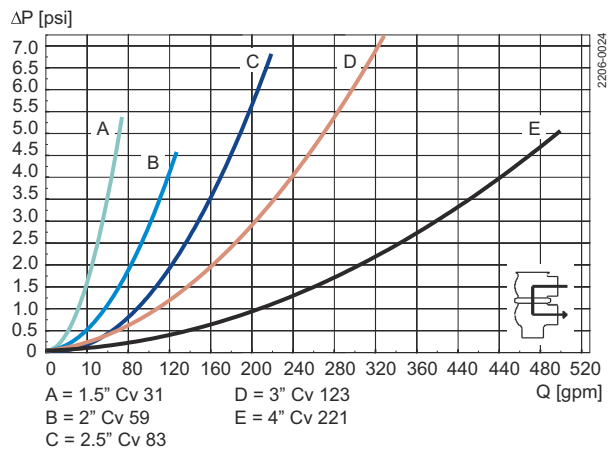
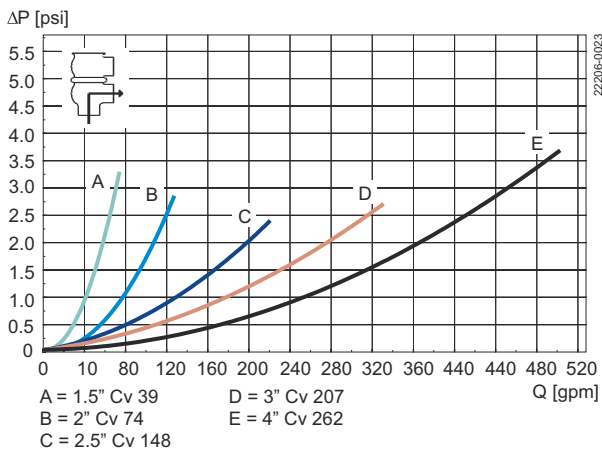
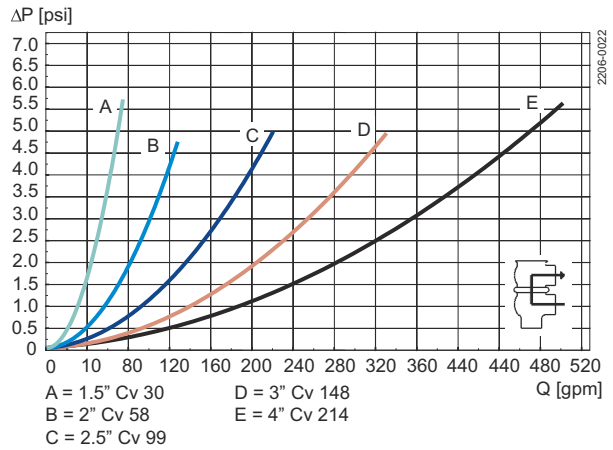
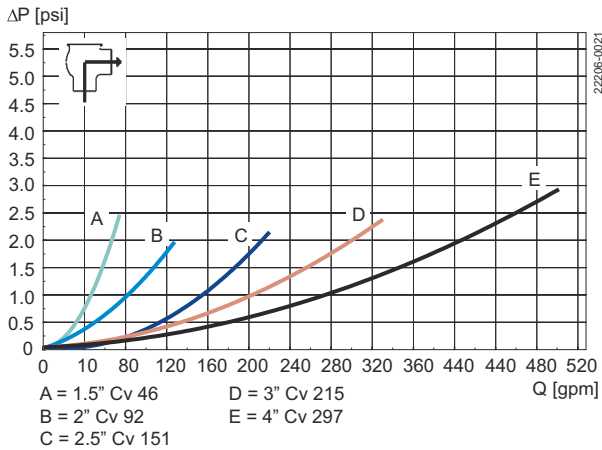
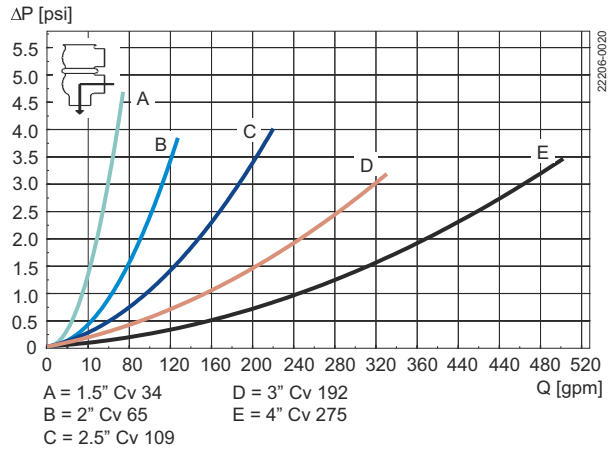
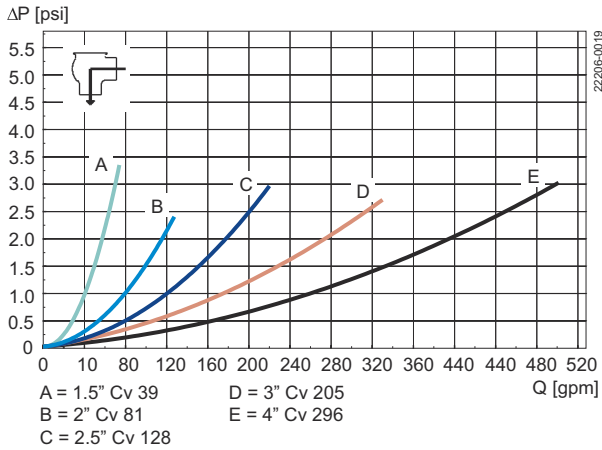

**Note!**

For the diagrams the following applies:

Medium: Water (68°F)

Measurement: In accordance with VDI 2173

Pressure drop can also be calculated in Anytime configurator.

Pressure drop can also be calculated with the following formula:

$$Q = C_v \times \sqrt{\Delta p}$$

Where

Q = Flow (gallon/minute).

Cv = gallon/minute at a pressure drop of 1 psi (see table above).

Δp = Pressure drop in psi over the valve.

How to calculate the pressure drop for an ISO 2.5" shut-off valve if the flow is 160 gallon/minute.

2.5" shut-off valve, where Cv = 128 (See table above).

$$Q = K_v \times \sqrt{\Delta p}$$

$$160 = 128 \times \sqrt{\Delta p}$$

$$\Delta p = \left(\frac{160}{128}\right)^2 = 1,6 \text{ psi}$$

(This is approx. the same pressure drop by reading the y-axis above)

Pressure data for Unique Single Seat Valve Two Step

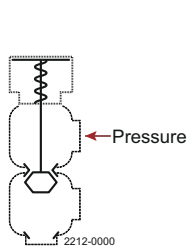

Figure 2. 1

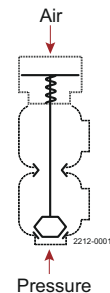

Figure 3. 2

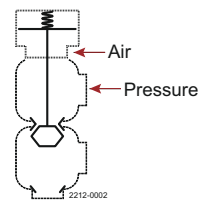

Figure 4. 3

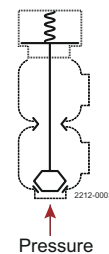

Figure 5. 4

Shut-off and Change-over valves

| Actuator / Valve body combination and direction of pressure | Air pressure (PSI) | Plug position | Max. pressure in PSI without leakage at the valve seat | | | | |
|---|--------------------|---------------|--|----------|-----------|----------|----------|
| | | | Valve size | | | | |
| | | | DN/OD 1½" | DN/OD 2" | DN/OD 2½" | DN/OD 3" | DN/OD 4" |
| 1 | | NO | 145 | 122 | 65 | 99 | 64 |
| 2 | 87 | NO | 145 | 139 | 81 | 104 | 70 |
| 3 | 87 | NC | 145 | 145 | 88 | 112 | 73 |
| 4 | | NC | 145 | 104 | 61 | 93 | 61 |

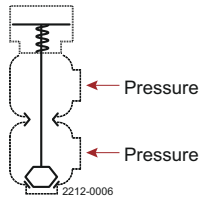

Figure 6.5

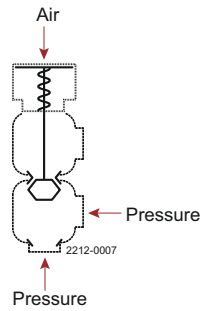

Figure 7.6

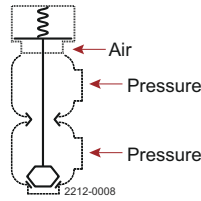

Figure 8.7

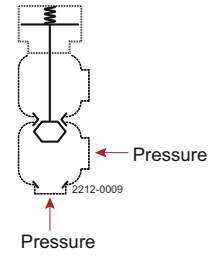

Figure 9.8

Shut-off and Change-over valves

| Actuator / Valve body combination and direction of pressure | Air pressure (PSI) | Plug position | Max. pressure in PSI against which the valve can open | | | | |
|---|--------------------|---------------|---|---------------------|-----------------------|----------------------|-----------------------|
| | | | Valve size | | | | |
| | | | DN 40 DN/OD 1½" | DN50 DN/OD 2" | DN 65 DN/OD 2½" | DN 80 DN/OD 3" | DN 100 DN/OD 4" |
| 5 | | NO | 145 | 145 | 68 | 141 | 91 |
| 6 | 87 | NO | 145 | 145 | 120 | 145 | 96 |
| 7 | 87 | NC | 145 | 145 | 131 | 145 | 100 |
| 8 | | NC | 145 | 145 | 99 | 132 | 88 |

Shut-off and Change-over valves with high pressure actuator option (option)

| Actuator / Valve body combination and direction of pressure | Air pressure (PSI) | Plug position | Max. pressure in PSI without leakage at the valve seat | |
|---|--------------------|---------------|--|--------------|
| | | | Valve size | |
| | | | DN/OD 2" | DN/OD 2½" |
| 1 | | NO | 145 | 145 |
| 2 | 87 | NO | 145 | 145 |
| 3 | 87 | NC | 145 | 145 |
| 4 | | NC | 145 | 145 |

This document and its contents are subject to copyrights and other intellectual property rights owned by Alfa Laval Corporate AB. No part of this document may be copied, re-produced or transmitted in any form or by any means, or for any purpose, without Alfa Laval Corporate AB's prior express written permission. Information and services provided in this document are made as a benefit and service to the user, and no representations or warranties are made about the accuracy or suitability of this information and these services for any purpose. All rights are reserved.

How to contact Alfa Laval

Up-to-date Alfa Laval contact details for all countries are always available on our website at www.alfalaval.com