

COMMON FINISHES		
DESIGNATION	PROCESS CONTACT	NON-PROCESS CONTACT
-1	MILL	MILL
-7	32 RA	32 RA
-PL	20 RA	32 RA
-PO	20 RA EP	32 RA
-PM	15 RA EP	32 RA

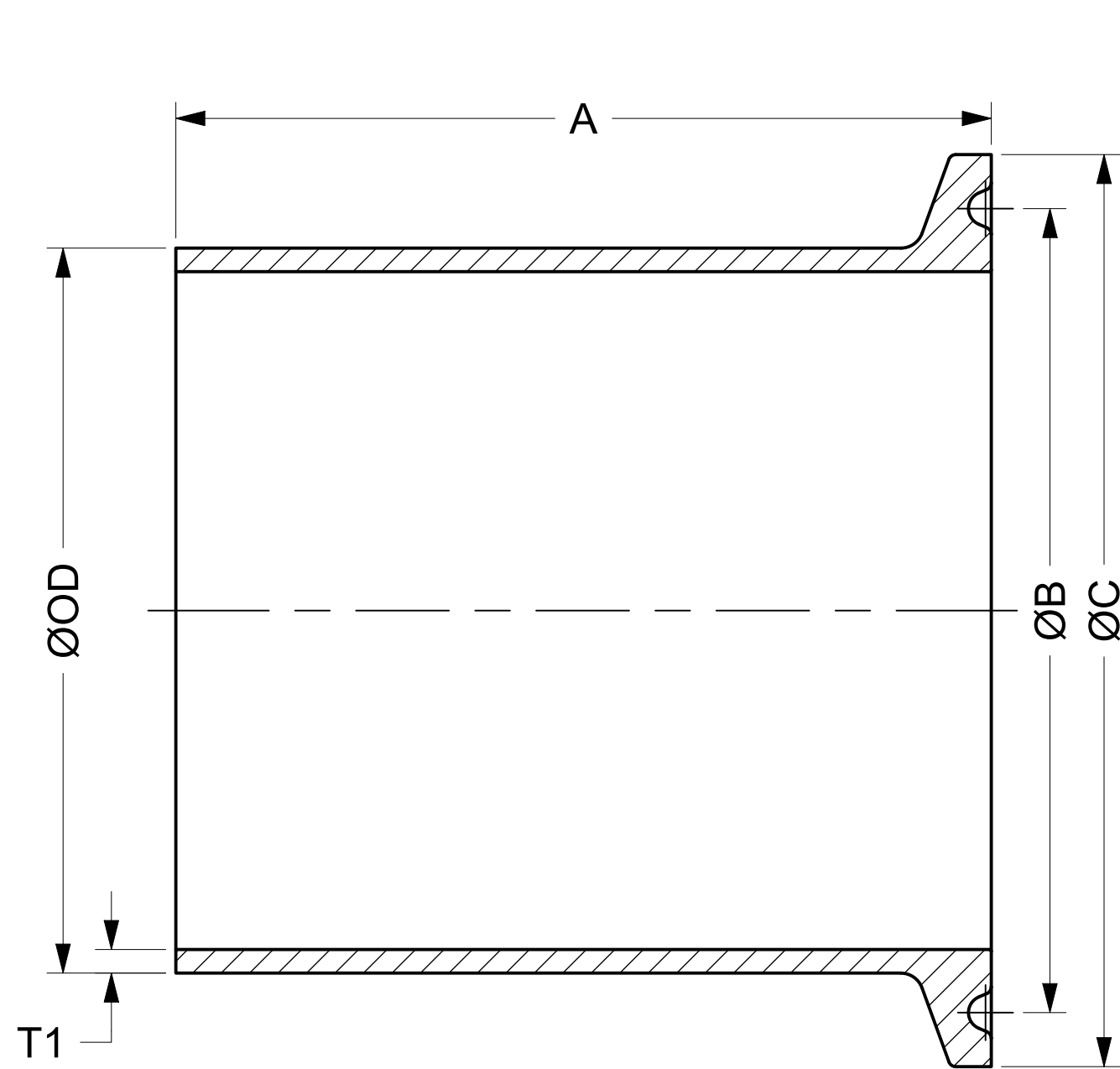

SECTION A-A

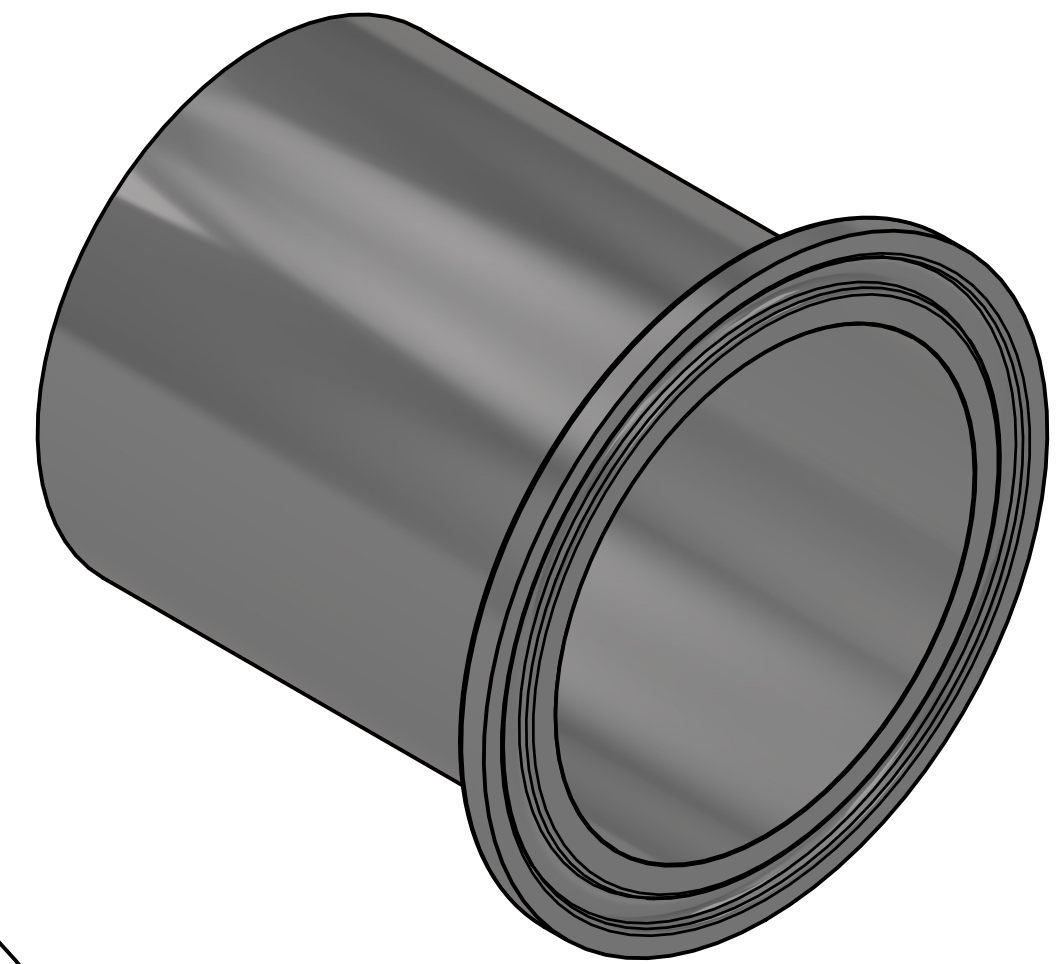
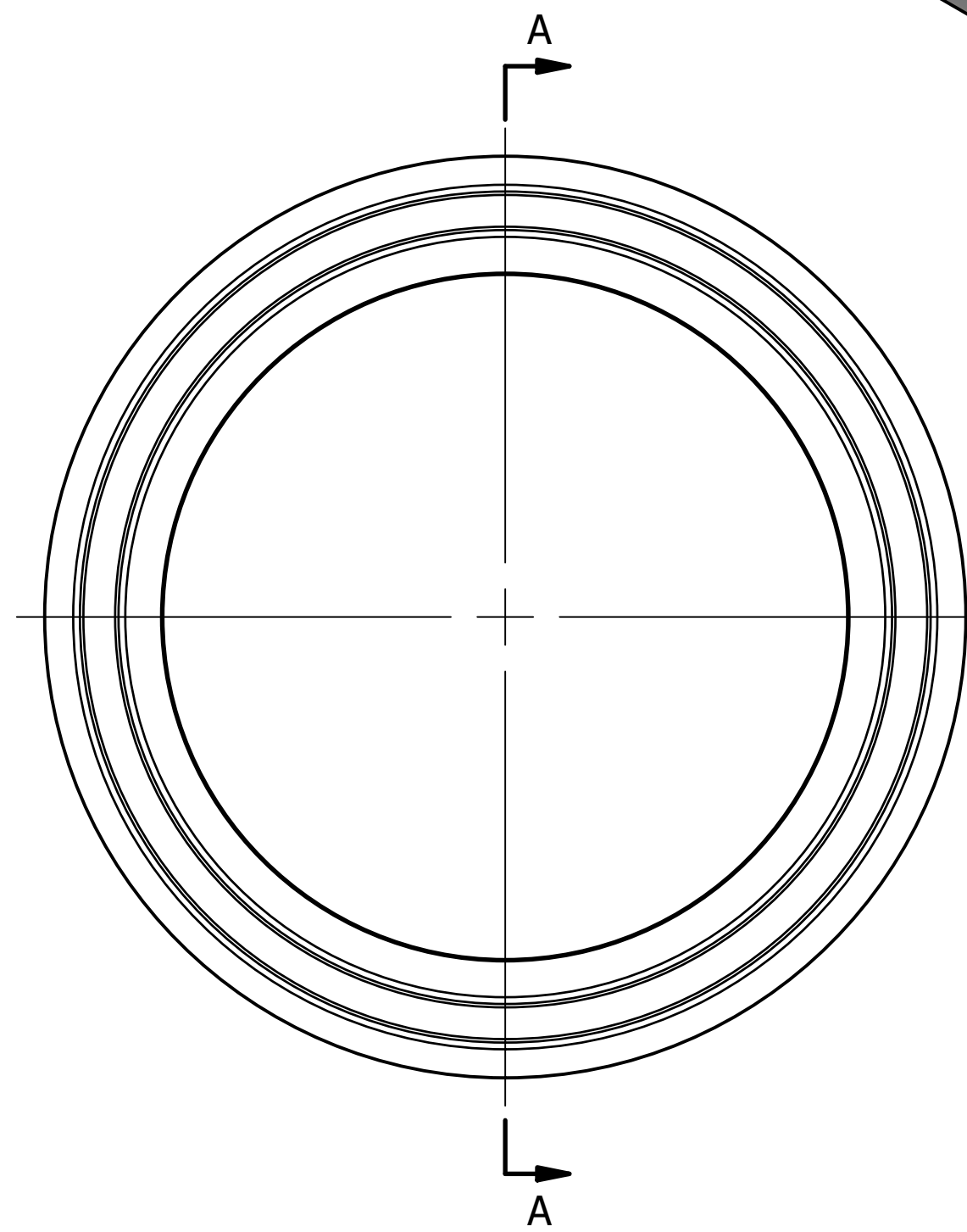

NOMINAL SIZE		A		B		C		OD		T1	
IN	MM	IN	MM	IN	MM	IN	MM	IN	MM	IN	MM
0.25	6.35	1.750	44.45	0.800	20.32	0.984	24.99	0.250	6.35	0.035	0.89
0.375	9.53	1.750	44.45	0.800	20.32	0.984	24.99	0.375	9.53	0.035	0.89
0.5	12.70	1.750	44.45	0.800	20.32	0.984	24.99	0.500	12.70	0.065	1.65
0.75	19.05	1.750	44.45	0.800	20.32	0.984	24.99	0.750	19.05	0.065	1.65
1	25.40	1.750	44.45	1.718	43.64	1.984	50.39	1.000	25.40	0.065	1.65
1.5	38.10	1.750	44.45	1.718	43.64	1.984	50.39	1.500	38.10	0.065	1.65
2	50.80	2.250	57.15	2.218	56.34	2.516	63.91	2.000	50.80	0.065	1.65
2.5	63.50	2.250	57.15	2.781	70.64	3.047	77.39	2.500	63.50	0.065	1.65
3	76.20	2.250	57.15	3.281	83.34	3.579	90.91	3.000	76.20	0.065	1.65
4	101.60	2.250	57.15	4.344	110.34	4.682	118.92	4.000	101.60	0.083	2.11
6	152.40	3.000	76.20	6.176	156.87	6.570	166.88	6.000	152.40	0.109	2.77

* INFORMATION PROVIDED IN THIS DRAWING IS FOR REFERENCE ONLY. FINISH AVAILABILITY DEPENDANT ON MATERIAL



PART NO.: **BS14AM**

DESCRIPTION: **LONG FERRULE, TC X BW**

MATERIAL OPTIONS:
316/316L SS

DWG NO.: **CDBS14AM**
CREATION DATE: 30JUL2025
SHEET: 1 OF 1

REV. **B**