

# Alfa Laval ThinkTop<sup>®</sup> V55

## Sensing and control

### Introduction

The Alfa Laval ThinkTop V55 is a slimmer, smarter, one-size-fits-all sensing and control unit for diaphragm valves used in the pharmaceutical, biotech, and next-generation food industries.

Built on the reliable Alfa Laval ThinkTop V-series platform, this valve control unit is trusted by dairy, food, beverage, and brewery manufacturers worldwide for its simplified setup, live replacement and unmatched peace of mind.

### Application

ThinkTop V55 is designed for use in the biopharma industries, dairy, food and beverage.

### Benefits

A single, proven diaphragm valve sensing and control unit

- Peace of mind – optimize valve control and increase uptime
- Simplified setup and replacement – save time and money with fast, intuitive valve configuration and replacement without production stops
- Compact and flexible – slimmer profile fits into tight spaces, minimizing installation footprint and maximizing plant efficiency
- Real-time monitoring and control – choice of digital, ASI, and Industry 4.0-based IO-Link communication platforms
- Self-diagnostic technology – prevent unplanned downtime by monitoring valve health and performance

### Certificates

A selection of the essential certificates available on ThinkTop:



### Working principles

The control unit offers a single sensor solution for diaphragm valves, and it can be fitted with 0 or 1 solenoid valves. ThinkTop converts the electrical PLC output signals into mechanical energy to energize, or de-energize, the air-operated valve. Feedback of valve position is provided using the physical sensor target mounted on the valve stem.

Installation with Auto Setup or Live Setup is intuitive and fast. To initiate Auto Setup, simply press the “SELECT” button and then



the “ENTER” button to begin the setup sequence. The ThinkTop automatically recognizes the type of valve and completes the programming sequence fast and efficiently.

Alternatively, the ThinkTop can be set up, without dismantling the control head, using the built-in Live Setup feature for remote configuration.

## Dimensions

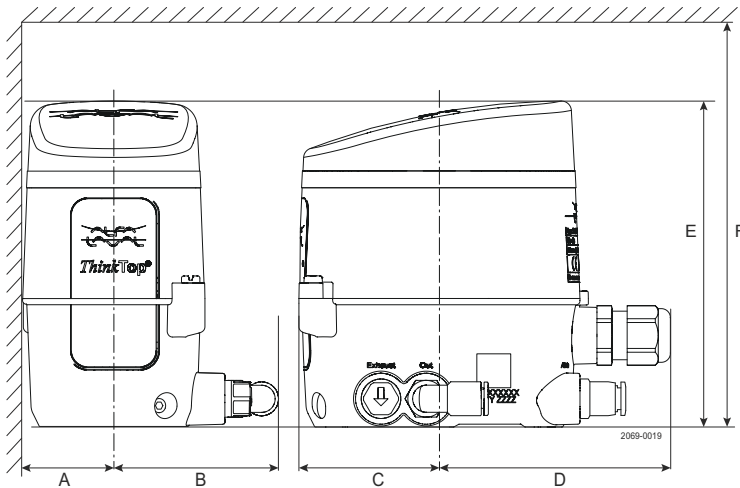

Figure 1. ThinkTop V55

	mm	Inch
A	35	1.38
B	70	2.76
C	50	1.97
D	80	3.15
E	120	4.72
F	180	7.09

## Technical Data

### Material

Plastic parts	Nylon PA 12
Steel parts	1.4301 / 304
Gaskets	Nitril / NBR
Air fittings	Nickel plated / Nylon PA6
M12 chassis connector	Stainless steel / Gold plated pins

### Environment

Working temperature	-10 °C to +60 °C / +14 °F to +140 °F
Protection class (IP)	IP69K
Protection class (NEMA)	4, 4X and 6
Hazardous area	Not available yet ATEX and IEC-Ex

### Control board

Communication	See interfaces section
Sensor accuracy	± 0.1 mm / ± 0.04"
Mean Time To Failure (MTTF)	224 years
Approvals	UL/CSA Certificate: E174191

### Solenoid valve

Supply voltage	24 VDC ± 10%
Nominal power	0.3 W
Air supply	300-800 kPa (3-8 bar)
Type of solenoids	3/2-ways
Number of solenoids	0-1
Manual hold override	Yes
Air quality	Class 3,3,3 acc. DIN ISO 8573-1
Air pressure	6-8 bar
B10 data	5 million cycles
Recommendation	Operate once a month to prevent dry-out



Throughout this document, SV is used as an abbreviation for a solenoid valve.

**Air fitting**

Threaded air fitting G1/8	ø6 mm (Rim blue) or 1/4" (Rim Grey)
Elbow push-in fittings	ø6 mm (Smooth rim) or 1/4" (Grooved rim)

**Cable connection**

Main cable gland entry Digital	M16 (ø4 - ø10 mm <sup>2</sup> ) (0.16" - 0.39")
Main cable gland entry AS-I	M16 (ø2 - ø7 mm <sup>2</sup> ) (0.08" - 0.28")
Max wire diameter	0.75 mm <sup>2</sup> (AWG20)

**M12 chassis connector**

AS-Interface V55	2 wire, 4-pin series
IO-Link interface V55	3 wire, 4-pin series
Digital interface V55	6 wire, 8-pin series

**Vibration**

Vibration	18 Hz-1kHz @ 7.54 g RMS
Shock	100 g

**Humidity**

Constant humidity	+40 °C / +140 °F, 21 days, 93% RH
Cyclic humidity	-25 °C / +55 °C (-13 °F / +131 °F), 93% RH, 12 cycles

**Accessories by functionality**

Valve "opening" speed reduction	0-100%. Outlet air fitting on ThinkTop
Valve "closing" speed reduction	0-100%. Inlet air fitting on actuator
Valve closing speed increase	Quick air exhaust, Ø 6 mm / Ø 0.24"

**Operational Data**

**ThinkTop LED indication**

ThinkTop features a 360-degree light guide. When the sensor target is within the respective setup position band, the corresponding colour lights up.

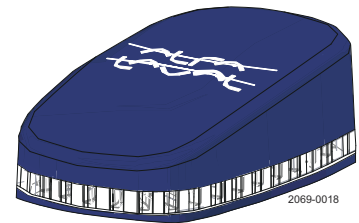
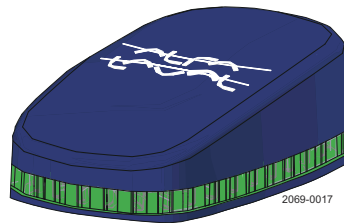

**Valve position**

	Actuator	<input checked="" type="checkbox"/> All De-energized	<input type="checkbox"/> Main valve open Energized
ThinkTop Mode	Factory setting	Green flashing	White flashing
	Operation	Green	White
	Not OK	Green/red flashing	White/red flashing

## Auto and Live setup

Auto Setup is a rule-based function. If one of these rules are not present, Flex Setup must be used.

By default, ThinkTop V55 uses the De-Energized/Energized paradigm for valve positions feedback.

Parameter	Auto Setup/Live Setup	Flex Setup (retrofit mode)
Status feedback (OK or error)	Valve state (Fail safe signal)	Status error
Valve operation monitor	Enabled	Disabled



The "Fail safe signal" is always high when no errors are detected in the valve or ThinkTop.

## Valve compatibility chart

Use Anytime configurator for correct selection of ThinkTop V55 on different valve size and types.

	Common applications (Auto / Live Setup)	Special applications (Flex Setup)	Incompatible valves
ThinkTop V55	<ul style="list-style-type: none"> <li>Diaphragm valves</li> <li>Small single seat valve</li> <li>Vacuum breaker valve</li> </ul>	<ul style="list-style-type: none"> <li>Feedback structure such as the open/closed valve feedback</li> <li>Application with no solenoid valve</li> <li>Alternative setup with no restrictions</li> </ul>	<ul style="list-style-type: none"> <li>Diaphragm Actuators SS/HP</li> <li>Mixproof valve</li> <li>Single Seat Valve ≥1"</li> <li>Butterfly Valve</li> <li>Koltek Shutter Valves</li> <li>Regulating Valves</li> <li>Safety Valves</li> <li>Sample Valves</li> <li>Ball Valves</li> <li>Other valve brands</li> </ul>

## Overview of control board V55

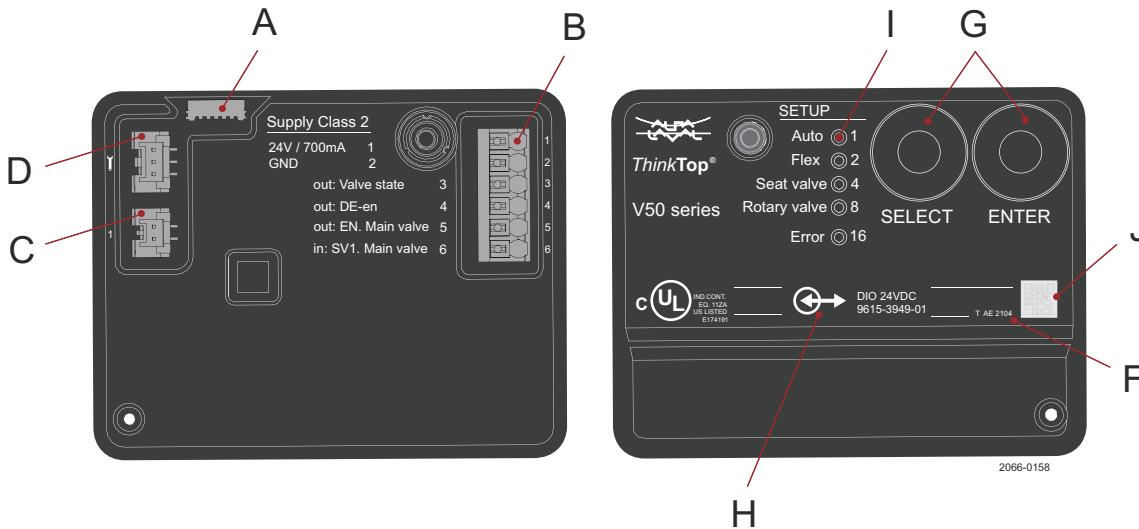

- A: LED indication lamp
- B: Spring loaded terminals
- C: Solenoid valve connectors
- D: Diagnostic port (Alfa Laval)
- E: Upper seat lift sensor terminal
- F: Control board - Firmware version
- G: Push buttons "Select" and "Enter"
- H: Symbol for electrical interface
- I: LEDs for unit status display
- J: Non-public QR code

## Valve state – Fail safe signal

The following table gives an overview of behaviour per Error condition where the valve state signal goes low. Further description of the various Error conditions can be found in the ThinkTop Instruction Manual available on [www.alfalaval.com](http://www.alfalaval.com) under ThinkTop V55 and documentation.

Valve state is a decentralized functionality, available for all ThinkTop variants and a feature that can be used for monitoring process issues or to ease and simplify the PLC programming of a valve surveillance.

Error Code #	Error description	ThinkTop Digital Valve state	ThinkTop AS-Interface Valve state not available	ThinkTop IO-Link Valve state
		Main valve FAIL SAFE SIGNAL DE-ENERGIZED SIGNAL behavior	Main valve not available DE-ENERGIZED SIGNAL behavior	Main valve FAIL SAFE SIGNAL DE-ENERGIZED SIGNAL behavior
15	Key lock active	na	na	na
16	Sensor target missing	Drops low	Drops low	Drops low
17	Setup prerequisite issue Missing peripherals	Not connected	Not connected	Not connected
18	Pneumatic part issue	Not connected	Not connected	Not connected
20	Position not reached	Drops low	Drops low	Drops low
21	Unexpected valve movement	Drops low	Drops low	Drops low
23	Solenoid valve 1 missing	Drops low	Not connected	Drops low
27	Output short circuit (Digital)	Drops low	Not connected	Not connected
28	Setup aborted	Not connected	Not connected	Not connected
29	Blocked button	Drops low	Not connected	Drops low
30	Voltage Low (Digital)	Drops low	Not connected	Not connected
30	Communication failure (IO-Link)	Not connected	Not connected	Drops low
31	Safety stop	Drops low	Drops low	Drops low
32 <sup>1</sup>	Pressure shock event	Not connected	Not connected	Not connected

<sup>1</sup> Only IO-Link. This event is not treated as an error

## Default bitmapping

The default settings apply to both Digital, AS-Interface and IO-Link

ThinkTop V55 truth signal table: default factory setting

	DE-EN (I0) close	MAIN (I1) open	Valve state (Fail safe signal)
DE-EN (No active SV)	1	0	1
MAIN SV1 active (O1)	0	1	1

## Digital interface

ThinkTop Digital 24V DC

Device name	ThinkTop V55 24V Digital - PNP
Voltage supply	24VDC ± 10%; according to EN 61131-2
Protection	<ul style="list-style-type: none"> <li>Reverse polarity (24VDC ± 10%); EN 61131-2</li> <li>Voltage interruption and brown-out; EN 61131</li> <li>Short circuit; EN 61131</li> </ul>
Current consumption	Nominal 30 mA (Idle)
Outputs to PLC	Max 100 mA (solenoid valve and seat lift sensor active)
PLC input card	Max rated 24V / 100 mA
UL supply	Class 2 according to cULus
Voltage-drop	Typical 3V at 50 mA
Terminal type	<ul style="list-style-type: none"> <li>Spring force push-in technology</li> <li>Supports nominal wire cross-section between 1.0 mm<sup>2</sup> [17AWG] and 0.30 mm<sup>2</sup> [22AWG]</li> <li>Supports wire and ferrules for wire cross-section of 0.75 mm<sup>2</sup> [18AWG] with pin length 12 mm</li> </ul>

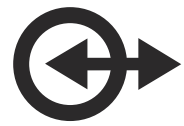

## Electrical connections

### V55 Digital-IO 24V

Terminal	Control Board		Colour code	M12 plug pin
1	24V	Power supply	BN (brown)	Pin: 1
2 <sup>1</sup>	GND	Power supply	BU (blue)	Pin: 3 <sup>1</sup>
3 <sup>1</sup>	Valve state	out (PLC in)	WH (white)	Pin: 2 <sup>1</sup>
4	Valve de-energised (DE-EN)	out (PLC in)	BK (black)	Pin: 4
5	Main valve energised (EN)	out (PLC in)	GY (grey)	Pin: 5
6	Solenoid valve 1 for main valve (SV1)	in (PLC out)	PK (pink)	Pin: 6

<sup>1</sup>Please be mindful of the difference between the number sequence of the control board terminal and the M12 plug pins.

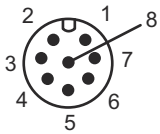

M12 option (8-pin A-coded plug).

## ThinkTop AS-Interface

Device name	ThinkTop V55 ASI2 & ThinkTop V55 ASI3
Supply voltage	AS-Interface 29.5 – 31.6 VDC
Protection	<ul style="list-style-type: none"> <li>Reverse polarity (24 VDC ± 10%); EN 61131-2</li> <li>Voltage interruption and brown-out; EN 61131</li> <li>Short circuit; EN 61131</li> </ul>
Current consumption	<ul style="list-style-type: none"> <li>Nominal: 30 mA (idle)</li> <li>Max 100 mA (solenoid valve and seat lift sensor active)</li> </ul>
Terminal type	<ul style="list-style-type: none"> <li>Spring force push-in technology</li> <li>Supports nominal wire cross-section between 1.0 mm<sup>2</sup> [17AWG] and 0.30 mm<sup>2</sup> [22AWG]</li> <li>Supports wire and ferrules for wire cross-section of 0.75 mm<sup>2</sup> [18AWG] with pin length 12 mm</li> </ul>
AS-I specification v2.11	<ul style="list-style-type: none"> <li>Supports standard addressing and are compatible with M0-M4 AS-I master profiles, allows up to 31 nodes on an AS-I network</li> <li><b>Slave profile = 7FFF</b></li> </ul>
AS-I specification v3.0	<ul style="list-style-type: none"> <li>Supports extended A/B addressing and is compatible with M4 AS-I master profile, allows up to 62 nodes on an AS-I network</li> <li><b>Slave profile = 7A77</b></li> </ul>
AS-I addressing	<ul style="list-style-type: none"> <li>Default slave address (Node) is = 0</li> <li>Address (Node) changes with a standard handheld AS-I addressing device or via AS-I Master Gateway</li> </ul>



## AS-Interface bit table

For the AS-Interface versions, the following bit assignment will be used

PLC system / Gateway Output table	ThinkTop V55
Pulse clean trigger (1 solenoid valve)	00
SV1. Main valve	01
PLC system / Gateway Input table	ThinkTop V55
DE-EN	I0
EN. Main valve	I1

## Electrical connections

### V55 AS-Interface

Terminal	Control Board		Colour code	M12 plug pin
1	ASi +	ASi supply	BN (brown)	Pin: 1
2	ASi -	ASi supply	BU (blue)	Pin: 3



M12 option (4-pin A-coded plug)

## IO-Link interface

### ThinkTop IO-Link

In addition to process indication and control, the IO-Link variant enables diagnostic information and features additional functionality that is unique to ThinkTop.

If new functionality is implemented in ThinkTop V55, then a new IO-Link IODD and interface description is generated. Both the new and old IO-Link IODD will be included in the latest revision of the "ThinkTop IO-Link zip-file".

It is recommended to just add them all to the preferred IO-Link configuration tool. The configuration tool will automatically match the correct IO-Link IODD with the connected ThinkTop.

Device name	ThinkTop V55 IOL
IO-Link supply voltage	24 VDC $\pm$ 10%; according to EN 61131-2
Protection	<ul style="list-style-type: none"> <li>Reverse polarity (24 VDC <math>\pm</math> 10%); EN 61131-2</li> <li>Voltage interruption and brown-out; EN 61131</li> <li>Short circuit; EN 61131</li> </ul>
Current consumption	<ul style="list-style-type: none"> <li>Nominal: 30 mA (idle)</li> <li>Max 100 mA (solenoid valve and seat lift sensor active)</li> </ul>
Terminal type	<ul style="list-style-type: none"> <li>Spring force push-in technology</li> <li>Supports nominal wire cross-section between 1.0 mm<sup>2</sup> [17AWG] and 0.30 mm<sup>2</sup> [22AWG]</li> <li>Supports wire and ferrules for wire cross-section of 0.75 mm<sup>2</sup> [18AWG] with pin length 12 mm</li> </ul>
ThinkTop control board revisions	AE
Download of IO-Link files	<ul style="list-style-type: none"> <li>Alfa Laval Anytime and ThinkTop configurator</li> <li>Go to <a href="http://www.alfalaval.com">www.alfalaval.com</a> ThinkTop V55 and documentation</li> </ul>
IO-Link interface tool	<ul style="list-style-type: none"> <li>IFM E30390 IO-Link Interface / USB IO-Link master</li> <li>IFM LR Device – Line recorder</li> </ul>
<b>ThinkTop V55</b>	ID 9
Cable length to IO-Link master	Max 20 meters
Transmission rate	COM 2 (38.4 kBaud)
Minimum cycle time	5 ms
Data storage	yes
Profiles	na
SIO mode	no
Port class	A



## IO-Link data table

For the IO-Link version, the bit assignment and diagnostic data can be found in the manual "IO-Link Interface Description" for ThinkTop V55. Go to [www.alfalaval.com](http://www.alfalaval.com) ThinkTop V55 and documentation.

On ThinkTop V55 control board, using the IO-Link interface tool from IFM, all parameter settings and visualization data are available through the diagnostic connection port.

From the "IO-Link Interface Description" the table below shows an overview of the data storage parameters. When replacing a ThinkTop V-series on a process plant, some data are re-stored, included in the new ThinkTop V-series, and other data must be reassigned again, excluded in the new ThinkTop V-series.

Please note that data storage is a feature that must be actively selected in the PLC's hardware configuration when setting up the IO-link master.

Included	Excluded
Customization <ul style="list-style-type: none"> <li>• Application Specific Tag</li> <li>• Error modifier timeout</li> <li>• Function Tag</li> <li>• Location Tag</li> <li>• Power save</li> <li>• Button lock</li> <li>• RGB colour</li> <li>• USA bit mapping</li> </ul>	Control board ID <ul style="list-style-type: none"> <li>• Vendor Name</li> <li>• Vendor Text</li> <li>• Product Name</li> <li>• Product ID</li> <li>• Product Text</li> <li>• Serial Number</li> <li>• Hardware Version</li> <li>• Firmware Version</li> <li>• Prod Date</li> </ul>
	Setup data <ul style="list-style-type: none"> <li>• Setup positions</li> <li>• Setup state</li> </ul>
	Diagnostics <ul style="list-style-type: none"> <li>• SV-activations</li> <li>• SV-ON_time</li> <li>• PV-SetupStrokeEn</li> <li>• PV-SetupStrokeDeEn</li> <li>• PressureShockCnt</li> <li>• Temp</li> <li>• Log</li> </ul>

**Electrical connections**

**V55 IO-Link**

Terminal	Control Board		Colour code	M12 plug pin
1	L+ 24V	Power supply	BN (brown)	Pin: 1
2 <sup>1</sup>	L - GND	Power supply	BU (blue)	Pin: 3 <sup>1</sup>
3 <sup>1</sup>	IO-Link	Signal	BK (black)	Pin: 4 <sup>1</sup>

<sup>1</sup>Please be mindful of the difference between the number sequence of the control board terminal and the M12 plug pins.



M12 option (4-pin A-coded plug)

This document and its contents are subject to copyrights and other intellectual property rights owned by Alfa Laval AB (publ) or any of its affiliates (jointly "Alfa Laval"). No part of this document may be copied, re-produced or transmitted in any form or by any means, or for any purpose, without Alfa Laval's prior express written permission. Information and services provided in this document are made as a benefit and service to the user, and no representations or warranties are made about the accuracy or suitability of this information and these services for any purpose. All rights are reserved.

**How to contact Alfa Laval**

Up-to-date Alfa Laval contact details for all countries are always available on our website at [www.alfalaval.com](http://www.alfalaval.com)