

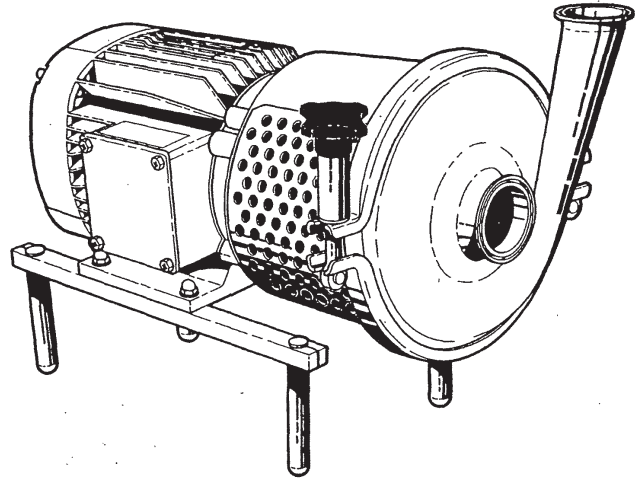

INSTRUCTION
MANUAL

GHC 1.2.3. CENTRIFUGAL PUMP

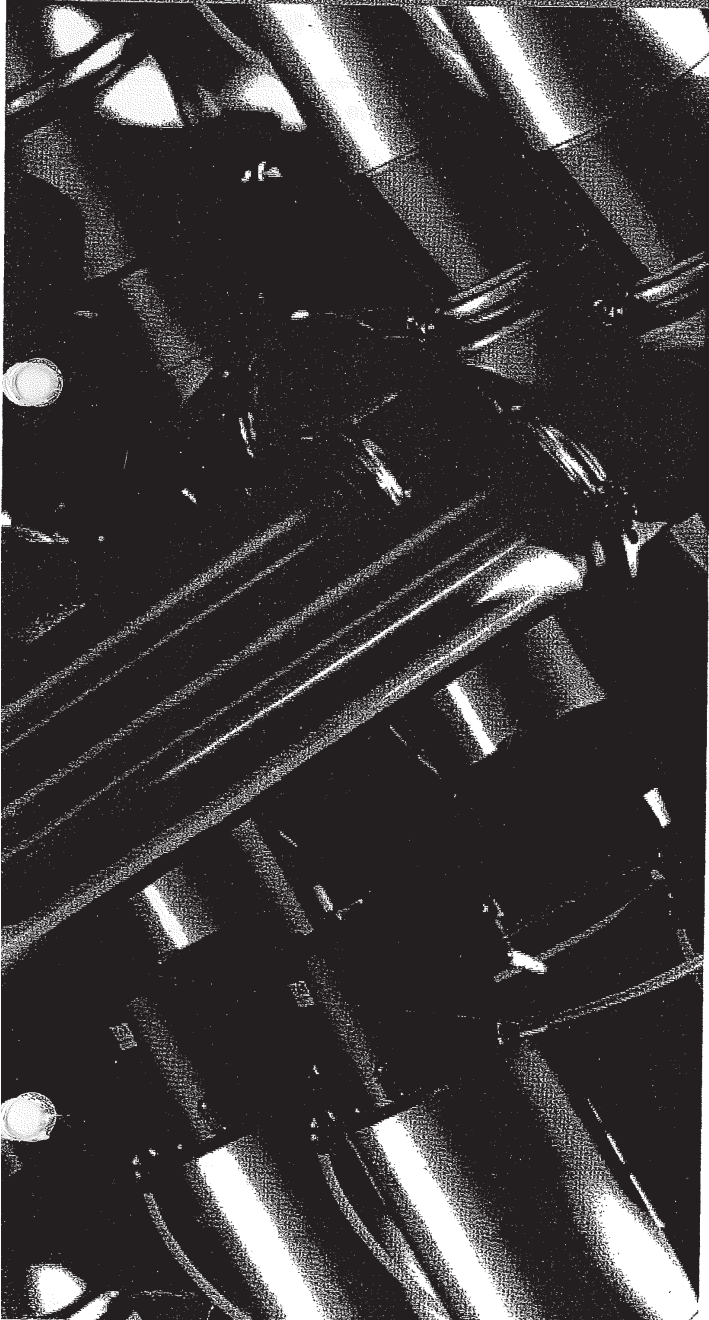

IM 70784-US1 S
9709

G&H RESERVE THE RIGHT TO
MINOR CHANGES IN DESIGN
AND FUNCTION

Introduction

Thank you for purchasing a G&H Product.

This manual has been provided to instruct you how to operate and service this product correctly and safely. Be sure to follow all directions and instructions; failure to do so could result in personal injury or equipment damage.

This manual should be considered part of this product and should remain with it at all times for reference. (If you sell it, please be sure to include this manual with it.)

Warranty is provided as part of G&H Products Corp.'s commitment to our customers who operate and maintain their equipment as this manual dictates. Failure to do so may result in loss of warranty.

Where defects appear on the product during the warranty period, G&H Products Corp. will back the product and correct the problem. Should the equipment be modified or not kept in the manner prescribed within this manual, the warranty will become null and void.



CSI

CONTACT CSI FOR MORE INFORMATION | CSIDESIGNS.COM | SALES@CSIDESIGNS.COM | 417.831.1411

Copyright © 2008 G&H Products Corp.
All Rights Reserved

This manual is divided into main sections. - See below.

Please note that the drawings on page 22 and 23 can support the reading of the manual.

Safety

- 1. Warning Signs 2
- 2. Safety Precautions 3

Installation

- 1. Unpacking/Delivery 4
- 2. Installation 5
- 3. Pre-Use Check 6

Operation

- 1. Operation/Control 7
- 2. Troubleshooting 8
- 3. Recommended Cleaning 9

Maintenance

- 1. General Maintenance 10
- 2. Disassembly of Pump/Shaft Seal 12
- 3. Assembly of Pump/Shaft Seal 16

Technical Data

- 1. Technical Data 21

Drawings/Parts List

- 1. Exploded Drawings
 - GHC Single shaft seal 22
 - GHC Double shaft seal 23
- 2. Drawing/Parts List
 - GHC 24

Information

- 1. Notes 27
- 2. User Feedback 27

Safety

2

Unsafe practices and other important information are emphasized in this manual.

Warnings are emphasized by means of special signs.

WARNING!

:

Indicates that special procedures **must** be followed to avoid severe personal injury.

CAUTION!

:

Indicates that special procedures **must** be followed to avoid damage to the equipment.

NOTE!

:

Indicates important information to simplify practices or to make them clearer.

Follow Safety Directions

Read this manual thoroughly before working on equipment.

Leave all safety stickers on equipment and keep them maintained in legible condition. In the event that stickers become damaged or are missing, contact G&H Products Corp. for replacements.

Maintain equipment in good working condition.

Do Not Make Machine Modifications

G&H Products Corp. offers a full range of products to suit all of your needs. Therefore, product modification is never necessary.

Keep Maintenance Safe

Replace damaged or worn parts immediately. Never allow old product, debris, or any lubricants to build up on equipment. Never operate unless equipment is in proper working order.

Before attempting to service the machine, disconnect all power and compressed air. Allow machine to come to a complete stop. Never service a machine while it is operating. Keep all limbs away from moving equipment. Be sure that product pressure has been relieved before beginning maintenance.

1. Warning Signs



:

General warning.



:

Dangerous electrical voltage.



:

Caustic agents.



CSI

CONTACT CSI FOR MORE INFORMATION | CSIDESIGNS.COM | SALES@CSIDESIGNS.COM | 417.831.1411

All warnings in the manual are summarized on this page.

Pay special attention to the instructions below so that severe personal injury or damage to the pump are avoided.

2. Safety Precautions

Installation:



: **Always** observe the technical data (see page 21).



: The pump **must** be electrically connected by authorized personnel (see the motor instructions).



: **Always** fit the clamp for the pump casing correctly.

Operation:



: - **Always** observe the technical data (see page 21).
 - **Never** touch the rotating shaft with your fingers or any tool when the pump is running.



: **Never** touch the pump or the pipelines when pumping hot liquids or when sterilizing.



: **Never** run the pump with both the suction side and the pressure side blocked.



: **Always** handle lye and acid with great care.

Maintenance:



: **Always** observe the technical data (see page 21).



: **Always** disconnect the power supply when the pump is serviced.



: - The pump must **never** be hot when serviced.
 - The pump and the pipelines must **never** be pressurized when the pump is serviced.



: **Always** fit the clamp for the pump casing correctly.



The instruction manual is part of the delivery.
Read the instructions carefully.

The standard delivery does not include the test certificate.
This can be supplied on request.

1. Unpacking/Delivery

1

NOTE!

G&H cannot be held responsible for incorrect unpacking.

Check the delivery:

1. Complete pump.
2. Packing list.
3. Instruction manual.
4. Motor instructions.
5. Test certificate, IF ORDERED!

2

Remove packing materials!

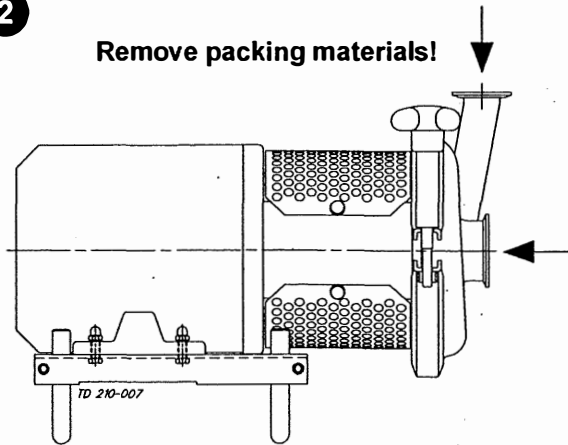

Clean the inlet and the outlet from possible packing materials.

3

Inspection!

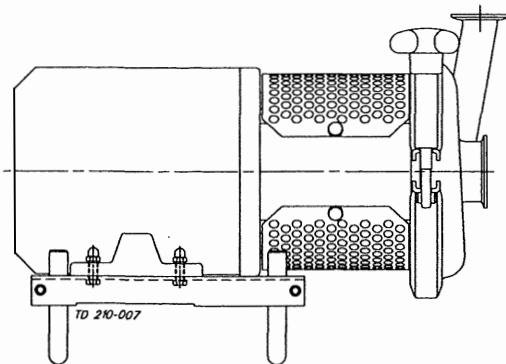

Inspect the pump for visible transport damage.

4

Caution!

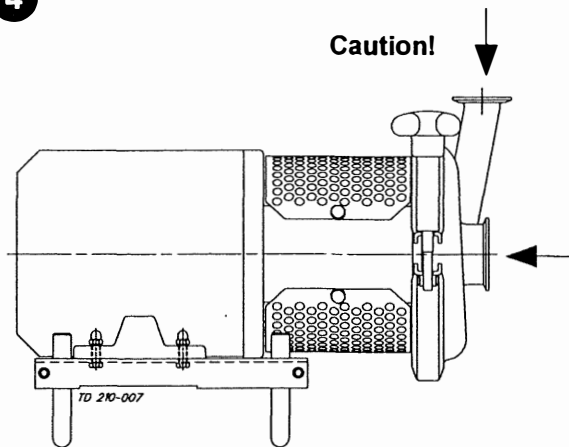

Avoid damaging the inlet and the outlet.

5

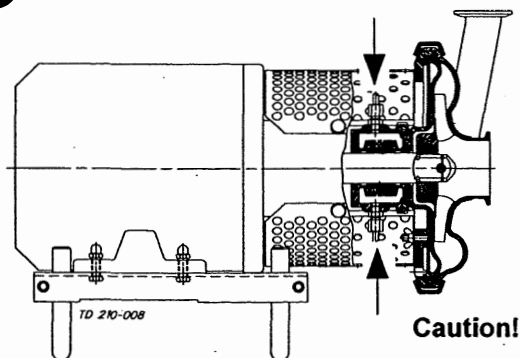

Avoid damaging the connections for flushing liquid, if supplied.



CSI

CONTACT CSI FOR MORE INFORMATION | CSIDESIGNS.COM | SALES@CSIDESIGNS.COM | 417.831.1411

Read the instructions carefully and pay special attention to the warnings!

Always check the pump before operation.
- See pre-use check on page 6.

2. Installation

1

 **Always** observe the technical data (see page 21).

 The pump **must** be electrically connected by authorized personnel (see the motor instructions).

NOTE!

G&H cannot be held responsible for incorrect installation.

2

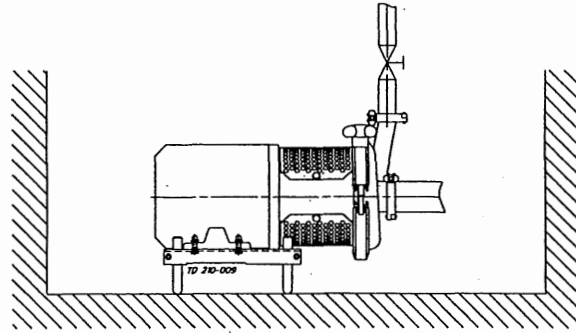

Ensure that there is sufficient clearance around the pump (min. 2 ft).

3

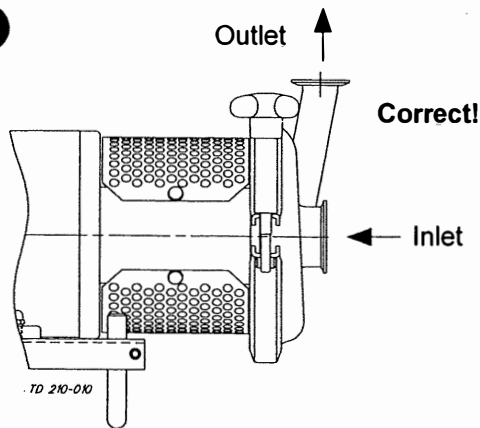

Ensure that the flow direction is correct.

4

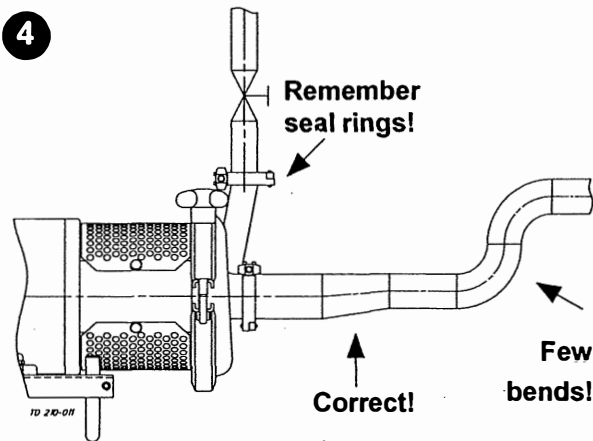

1. Ensure that the pipelines are routed correctly.
2. Ensure that the connections are tight.

5

Risk of damage!

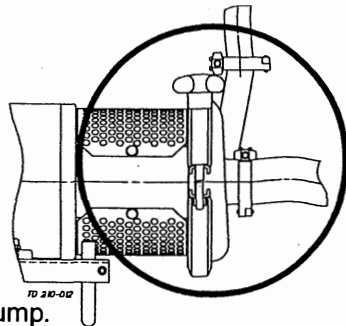

Avoid stressing the pump.
Pay special attention to:

- Vibrations.
- Thermal expansion of the tubes.
- Excessive welding.
- Overloading of the pipelines.

Installation

Read the instructions carefully and pay special attention to the warnings!
Check the clamp for the pump casing before operation.

Check the impeller position and the direction of rotation before operation.
- See the indication label on the pump.

3. Pre-Use Check - Clamp for Pump Casing

6

! Always fit the clamp for the pump casing correctly.

1. Ensure that clamp (7) is correctly fitted and tightened.
2. Check at handle (29) that there is metallic contact between adaptor (2) and pump casing (12).

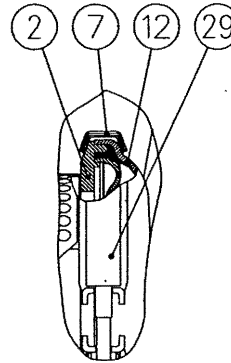

TD 210-017

Metallic contact required!

3. Pre-Use Check - Impeller Position and Direction of Rotation

1

! Always disconnect the power supply when checking the impeller position.

CAUTION!
Always ensure that the impeller rotates smoothly.

1. Rotate impeller (11) through the inlet.
2. Ensure that the impeller does not contact pump casing (12) or back plate (9).
3. Adjust the impeller position, if necessary (see page 16).

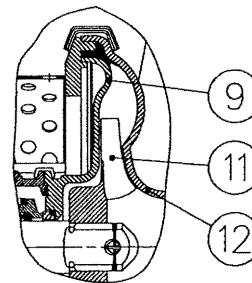

TD 210-018

Check the impeller through the inlet!

2

CAUTION!
Never check the direction of rotation with liquid in the pump.

1. Start and stop the motor momentarily.

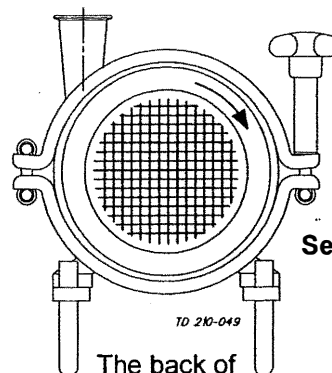

TD 210-049

Correct!

See the indication label!

The back of the motor.



Read the instructions carefully and pay special attention to the warnings!

The pump is fitted with a warning label indicating correct throttling.

1. Operation/Control

- 1**
-  - **Always** observe the technical data (see page 21).
 - **Never** touch the rotating shaft with your fingers or any tool when the pump is running.

NOTE!
G&H cannot be held responsible for incorrect operation/control.

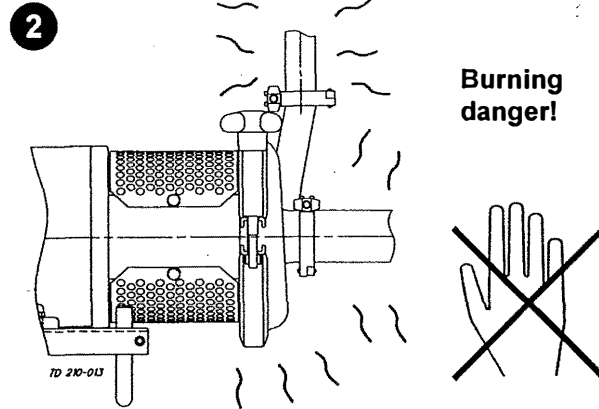

 **Never** touch the pump or the pipelines when pumping hot liquids or when sterilizing.

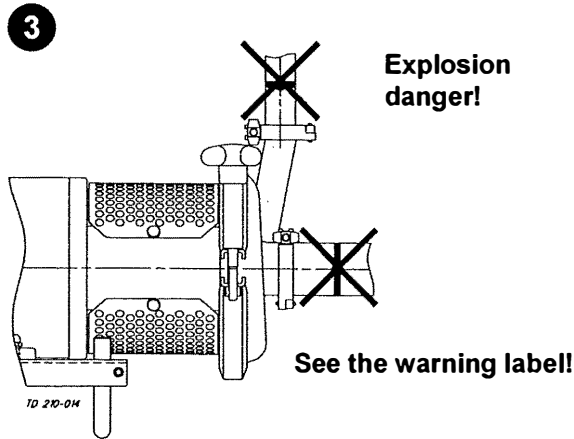

 **Never** run the pump with both the suction side and the pressure side blocked.

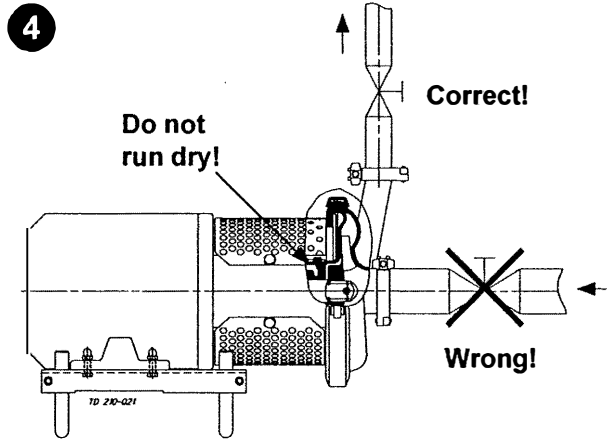

CAUTION!

- The shaft seal must not run dry.
- Never throttle the inlet side.

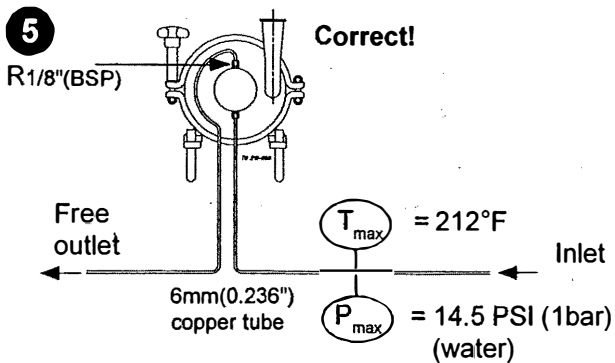

Flushed shaft seal:

1. Connect the inlet of the flushing liquid correctly.
2. Regulate the water and steam supply correctly.
3. Observe the steam data.

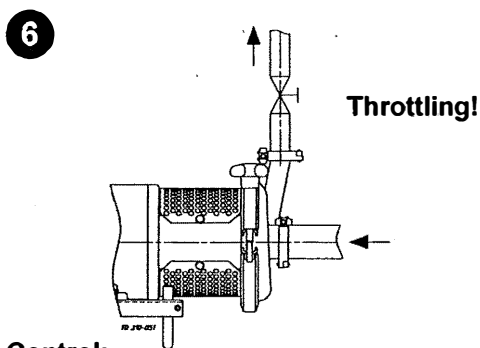

Control:
Reduce the capacity and the power consumption by means of:

- Throttling the pressure side of the pump.
- Reducing the impeller diameter.
- Speed control of the motor.

Pay attention to possible faults.

Read the instructions carefully.

2. Troubleshooting

NOTE!

Read the maintenance instructions carefully before replacing worn parts. - See Spare Part List.

8

Problem	Cause/Result	Repair
Overloaded motor	<ul style="list-style-type: none"> - Pumping of viscous liquids - Pumping of liquids with high density - Low outlet pressure (counter pressure) - Lamination of precipitates from the liquid 	<ul style="list-style-type: none"> - Larger motor or smaller impeller - Higher counter pressure (throttling) - Frequent cleaning
Cavitation: <ul style="list-style-type: none"> - Damage - Pressure reduction (sometimes to zero) - Increase in the noise level 	<ul style="list-style-type: none"> - Low inlet pressure - High liquid temperature 	<ul style="list-style-type: none"> - Increase the inlet pressure - Reduce the liquid temperature - Reduce the pressure drop before the pump
Leaking shaft seal	<ul style="list-style-type: none"> - Dry run (See page 7) - Incorrect rubber grade - Abrasive particles in the liquid 	Replace: All wearing parts (See Spare Part List) <ul style="list-style-type: none"> - Select a different rubber grade - Select stationary and rotating seal ring in Silicon Carbide/ Silicon Carbide
Leaking seals	Incorrect rubber grade	Select a different rubber grade



The pump is designed for cleaning in place (CIP).
CIP = Cleaning In Place.

Read the instructions carefully and pay special attention to the warnings!

NaOH = Caustic Soda.

HNO₃ = Nitric acid.

3. Recommended Cleaning

1

Caustic danger!



Always use rubber gloves!



Always use protective goggles!



Always handle lye and acid with great care.

3

Examples of cleaning agents:

Use clean water, free from chlorides.

- 1% by weight NaOH at 158°F.

1 kg NaOH	+	100 l water	= Cleaning agent
--------------	---	----------------	------------------

2.2 l 33%NaOH	+	100 l water	= Cleaning agent
------------------	---	----------------	------------------

- 0.5% by weight HNO₃ at 158°F.

0.7 l 53% HNO ₃	+	100 l water	= Cleaning agent
-------------------------------	---	----------------	------------------

5

Always rinse!

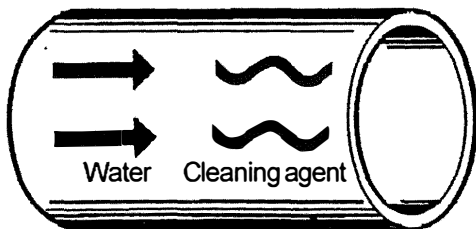

Always rinse well with clean water after the cleaning.

2

Burning danger!

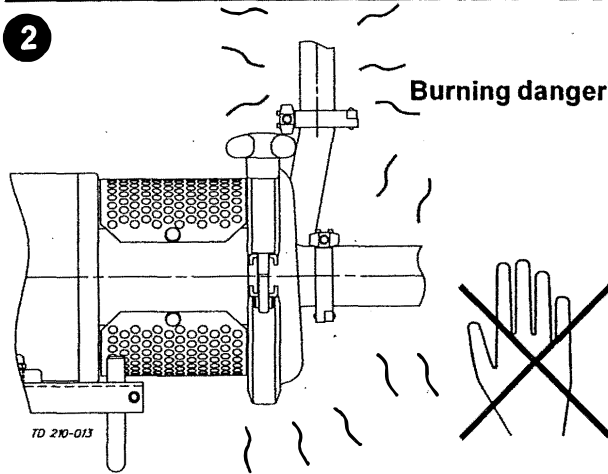

Never touch the pump or the pipelines when sterilizing.

4

- Avoid excessive concentration of the cleaning agent

⇒ **Dose gradually!**

- Adjust the cleaning flow to the process

Milk sterilization/viscous liquids

⇒ **Increase the cleaning flow!**

6

NOTE!

The cleaning agents must be stored/discharged in accordance with current rules/directives.

Maintain the pump carefully.
Read the instructions carefully and pay special attention to the warnings!

Always keep spare shaft seals and rubber seals in stock.
See separate motor instructions.

1. General Maintenance

1

⚠ Always observe the technical data (see page 21).

⚠ Always disconnect the power supply when the pump is serviced.

NOTE!
All scrap must be stored/discharged in accordance with current rules/directives.

2

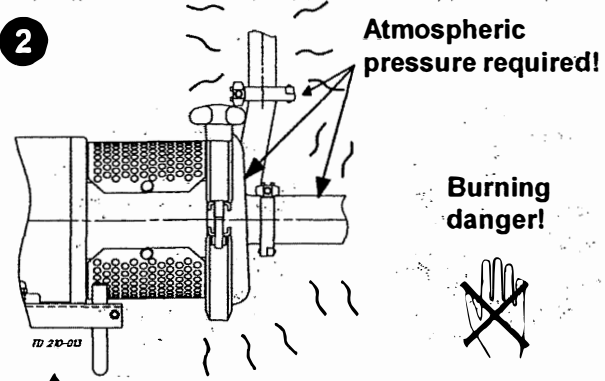

- ⚠ - The pump must **never** be hot when serviced.
- The pump and the pipelines must **never** be pressurized when the pump is serviced.

3

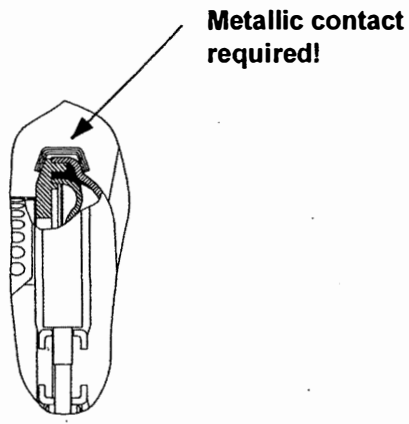

⚠ Always fit the clamp for the pump casing correctly after service (see pre-use check on page 6).

4

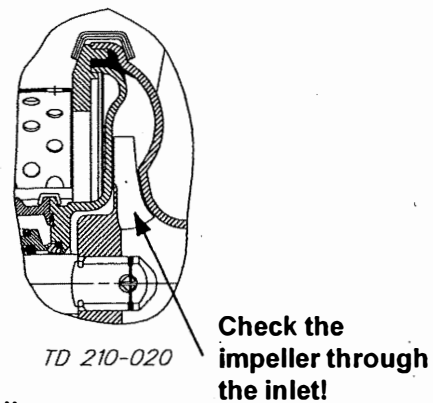

CAUTION!
Always ensure that the impeller rotates smoothly after service (see pre-use check on page 6).
Pay special attention to the warning!

CAUTION
Fit the electrical connections correctly if they have been removed from the motor during service (see pre-use check on page 6).

Pay special attention to the warnings!

Maintain the pump carefully.
Read the instructions carefully.

Always keep spare shaft seals and rubber seals in stock.
See separate motor instructions.
Check the pump for smooth operation after service.

1. General Maintenance

Ordering spare parts

- Contact the Sales Department.
- Order from the Spare Parts List.

Recommended spare parts: Service kits (see Spare Parts List).

	Shaft seal	Rubber seals	Motor bearings
Preventive maintenance	Replace after 12 months: (one-shift) Complete shaft seal	Replace when replacing the shaft seal	
Maintenance after leakage (leakage normally starts slowly)	Replace at the end of the day: Complete shaft seal	Replace when replacing the shaft seal	
Planned maintenance	<ul style="list-style-type: none"> - Regular inspection for leakage and smooth operation - Keep a record of the pump - Use the statistics for planning of inspections Replace after leakage: Complete shaft seal	Replace when replacing the shaft seal	Yearly inspection is recommended <ul style="list-style-type: none"> - Replace complete bearing if worn - Ensure that the bearing is axially locked (See motor instructions)
Lubrication	Before fitting Lubricate the O-rings with silicone grease or silicone oil (not the sealing surfaces)	Before fitting Silicone grease or silicone oil	None The bearings are permanently lubricated

Read the instructions carefully.
The items refer to the drawings and the parts list on pages 22-26.

Handle scrap correctly.

2. Disassembly of Pump/Removing the Single Shaft Seal

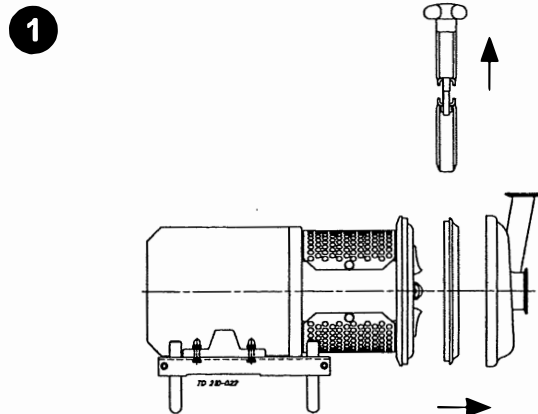

1. Remove clamp (7) pump casing (12) and casing gasket (8).
NOTE: If the pump casing is difficult to remove:
Knock gently with rubber mallet.

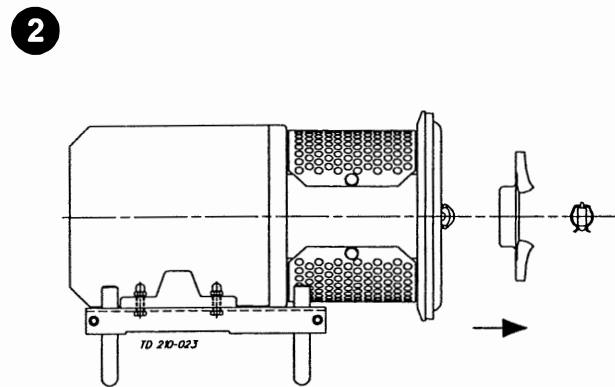

1. Remove pin (10) from hole in shaft.
2. Pull off impeller (11)

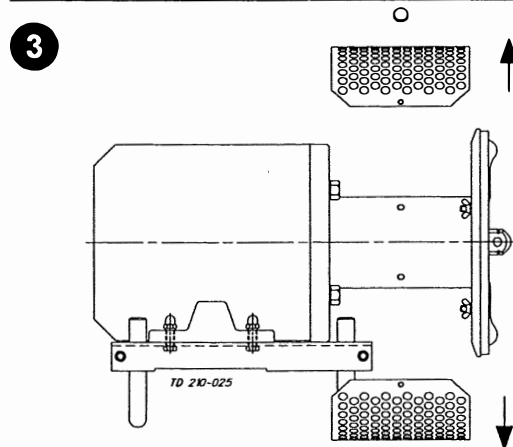

1. Remove screws (6) and OSHA shield (5) (GHC-1 only).

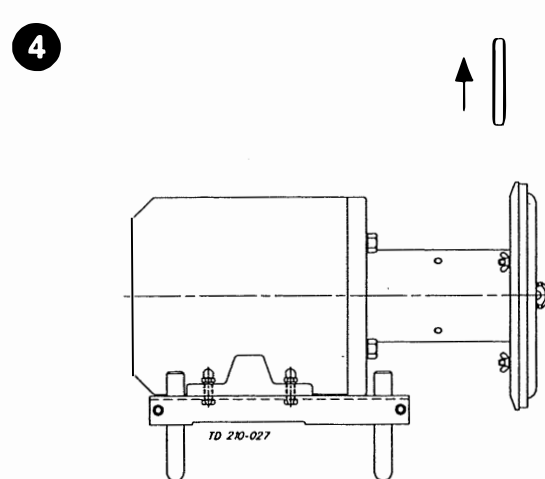

1. Remove clamp (22).

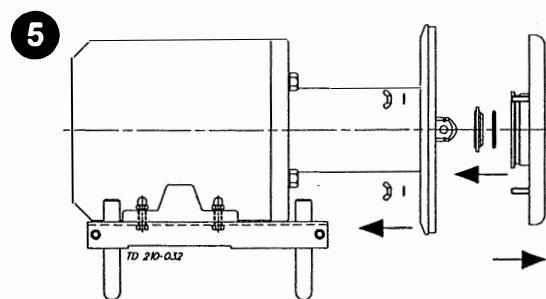

1. Remove wing nuts (14) and spring washers (13)
Pull off back plate (9) together with stationary seal ring.
2. Remove stationary seal ring (28) and O-ring (23) from backplate.

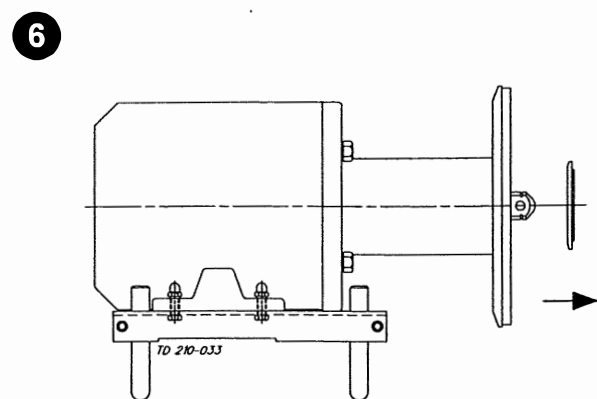

1. Remove retaining ring (37).



Read the instructions carefully.
The items refer to the drawings and the parts list on pages 22-26.

Handle scrap correctly.

2. Disassembly of Pump/Removing the Single Shaft Seal

7

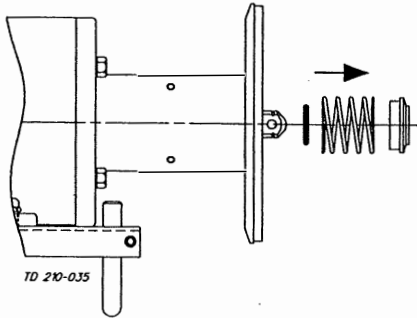

1. Pull off rotating seal ring (25) O-ring (24) and spring (26) .

8

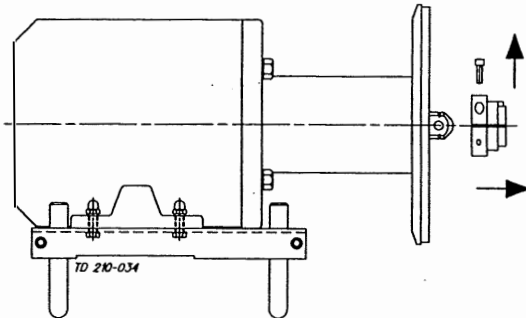

1. Loosen screw in adjusting collar (38) and pull it off pump shaft.

9

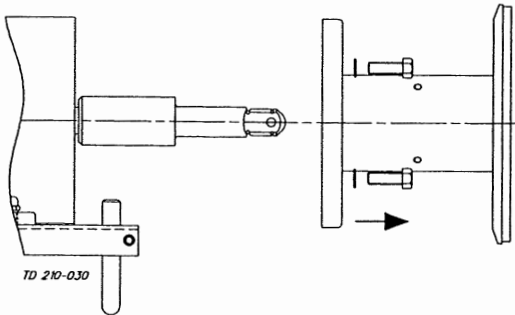

1. Remove screws (4) and the spring washers (3).
2. Pull off adaptor (2).

10

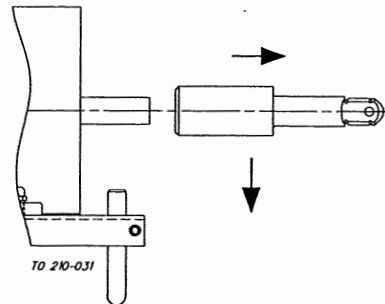

1. Loosen set screws (16), and pull shaft (15) off the motor shaft.

Read the instructions carefully.
The items refer to the drawings and the parts list on pages 22-26.

Handle scrap correctly.

14

2. Disassembly of Pump/Removing the Double Shaft Seal

1

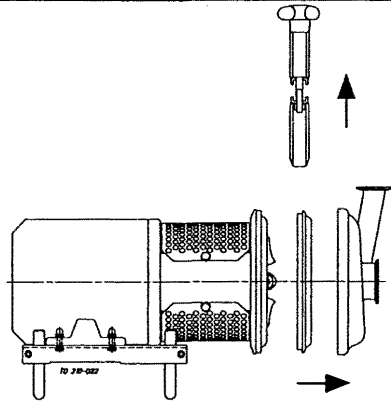

1. Remove clamp (7), pump casing (12) and casing gasket (8).

NOTE:

If the pump casing is difficult to remove:
Knock gently with rubber mallet.

2

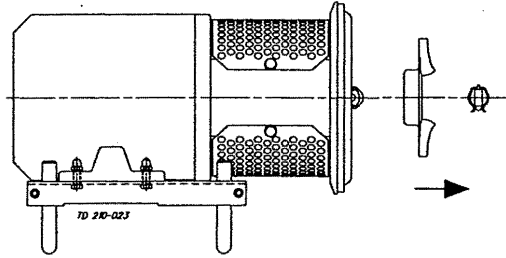

1. Remove the pin (10). Pull off impeller (11).

3

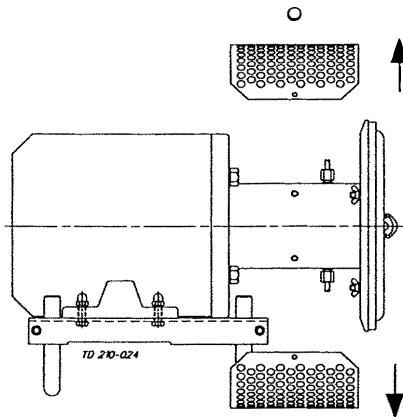

1. Remove screws (6) and OSHA shields (5) (GHC-1 only).

4

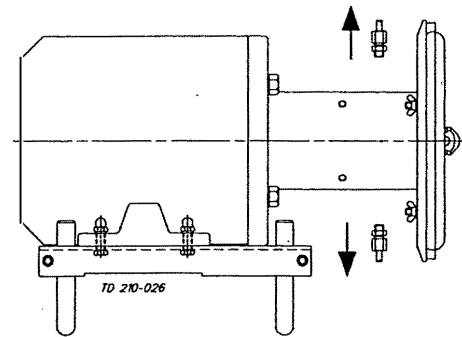

1. Remove seal-flushing water connections (18, 19).

5

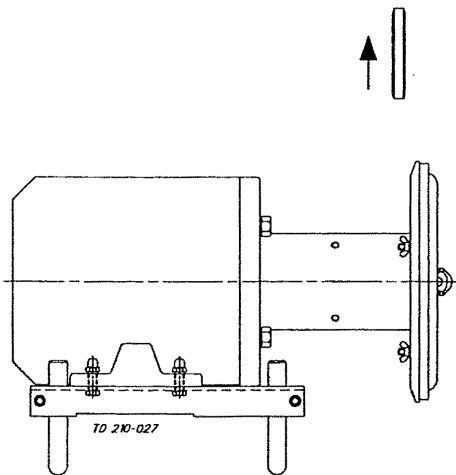

1. Remove clamp (22).

6

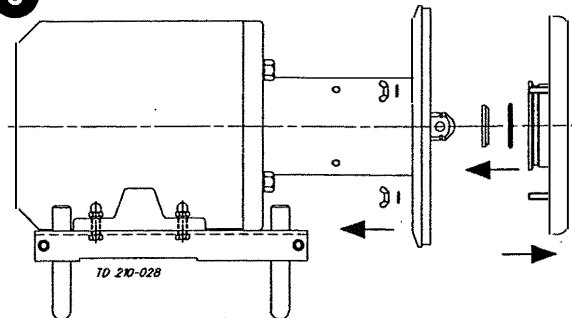

1. Remove wing nuts (14) and spring washers (13). Pull off back plate (9) together with stationary seal ring (28b).
2. Remove stationary seal ring (28b) and O-ring (23b) from back plate.



CSI

Read the instructions carefully.
The items refer to the drawings and the parts list on pages 22-26.

Handle scrap correctly.

2. Disassembly of Pump/Removing the Double Shaft Seal

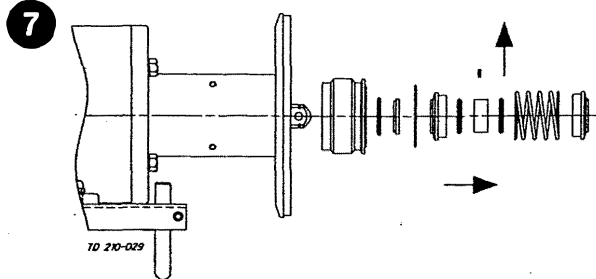

1. Pull off rotating seal ring (25b), spring (26) and O-ring (24b) (pumps side). Loosen screw (20) through one of the holes for seal-flushing water and pull off drive ring (21). Then pull the remaining seal parts and seal housing (17) off the shaft.
2. Remove stationary seal ring (28a), O-ring (23a) and O-ring (27) from seal housing.

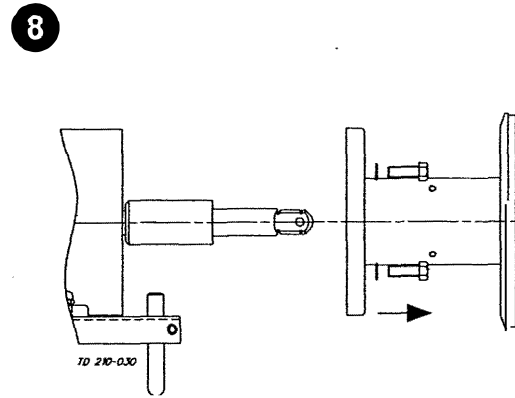

1. Remove screws (4) and the spring washers (3). Pull off the adaptor (2).

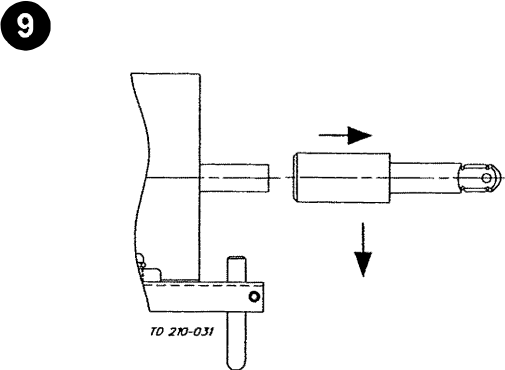

1. Loosen shaft set screws (16), and pull shaft (15) off the motorshaft.

Read the instructions carefully.
The items refer to the drawings and the parts list on the pages 22-26.

Lubricate the rubber seals before fitting them.

16

3. Assembly of Pump/Fitting the Single Shaft Seal

1

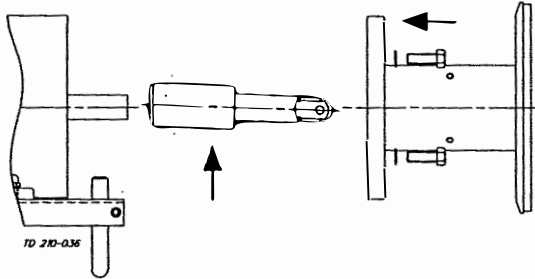

1. Push shaft (15) onto the motor shaft. Do not tighten shaft set screws (16).
2. Fit adaptor (2) and tighten with the four screws (4) and spring washers (3).

2

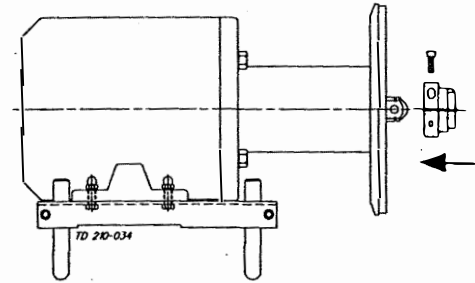

1. Push adjusting collar (38) as far as possible onto shaft with largest diameter towards the motor.

3

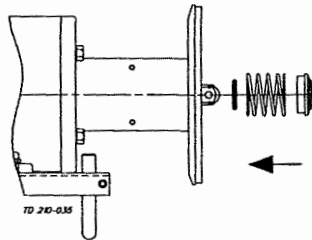

***CAUTION:**
When lubricating O-rings use silicone based lubricant. Do not use petroleum based lubricants.

1. Lubricate O-ring (24) with food grade silicone oil* and push it into the rotary seal (25).
2. Place spring (26) around the rotating seal ring (25) and push them onto the shaft and adjusting collar (38).
3. Check that the notch in the seal ring (25) is in the correct position so that the driver of the adjusting collar (38) enters the notch.

4

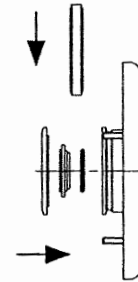

1. Lubricate and fit O-ring (23) onto stationary seal ring (28).
 2. Press stationary seal ring and O-ring into back plate (9).
 3. Fit retaining ring (37) and clamp (22) on the back plate.*
- * Stationary seal ring of silicone carbide is mounted without retaining ring and clamp.

5

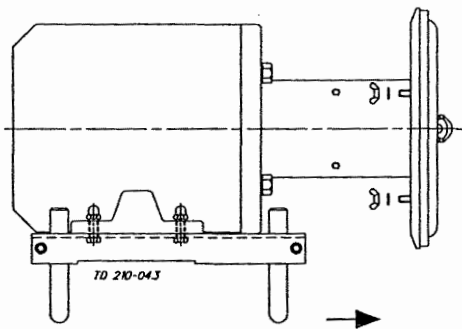

- Fit the back plate (9) and fasten with three wing nuts (14) and spring washers (13).

6

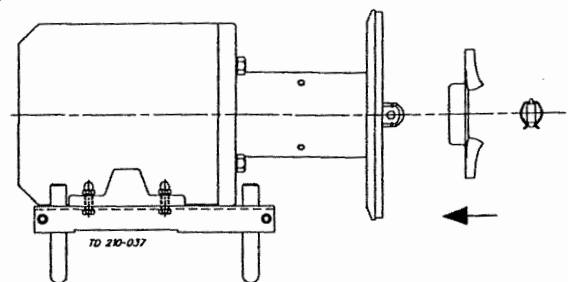

1. Fit impeller (11) on shaft. Insert pin (10) with clip in the hole at the shaft end and press the clip into the groove in the shaft.



CSI

CONTACT CSI FOR MORE INFORMATION | CSIDESIGNS.COM | SALES@CSIDESIGNS.COM | 417.831.1411

Read the instructions carefully.
The items refer to the drawings and the parts list on the pages 22-26.

Lubricate the rubber seals before fitting them.

3. Assembly of Pump/Fitting the Single Shaft Seal

17

7

Use depth gauge to check clearance between impeller and backplate. Proper clearance should be 0.02". Tighten the three shaft set screws (16) on shaft (15). Be careful so that the shaft does not move axially while being tightened.

9

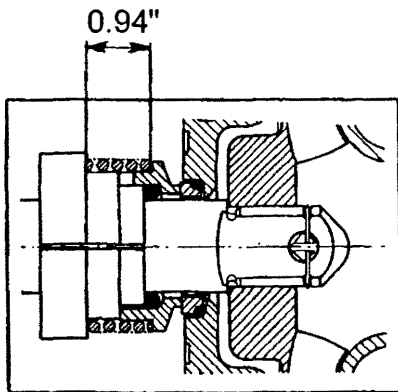

1. Adjust the adjusting collar (38) so that the distance 0.94"/24mm is achieved.
2. Check that the driver of the adjusting collar enters the notch in the rotating seal ring (25).
3. Tighten the set screw in the adjusting collar (38).

8

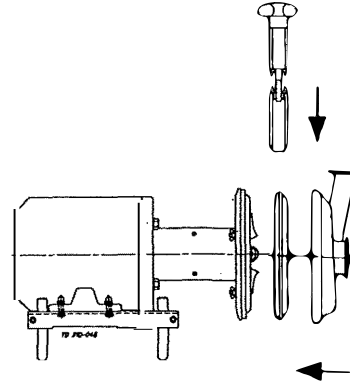

1. Lubricate and fit casing gasket (8) pump casing (12), and clamp (7).
2. Tighten the clamp to metallic contact casing/adaptor.

NOTE:

An incorrectly fitted clamp can cause serious damage.

10

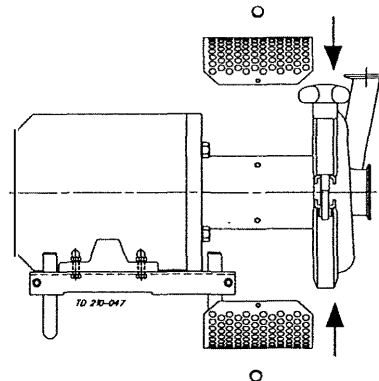

1. Check by turning the shaft that the impeller moves freely.
2. Install OSHA-shields (5) using screws (6) (GHC-1 only).

Read the instructions carefully.
The items refer to the drawings and the parts list on the pages 22-24.

Lubricate the rubber seals before fitting them.

3. Assembly of Pump/Fitting the Double Shaft Seal

1

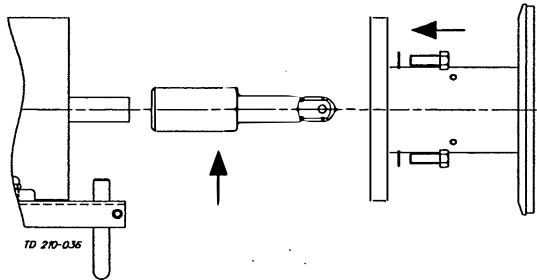

1. Push shaft (15) onto the motor shaft. Do not tighten shaft set screw (16).
2. Fit adaptor (2) and tighten with the four screws (4) and spring washers (3).

3

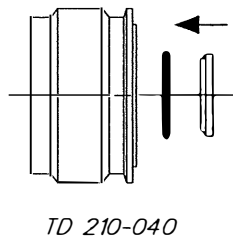

Fit O-ring (23a) onto stationary seal (28a) and press it into seal housing (17).

5

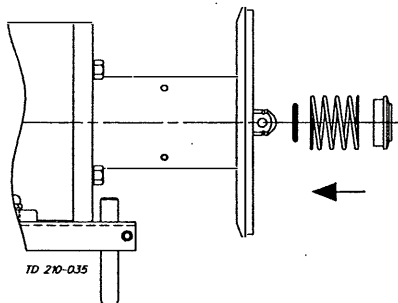

1. Fit spring (26), O-ring (24b) and rotating seal ring (25b) (pump side) on the shaft.

NOTE: The notches on the two rotating seal rings must be exactly opposite drive pin and set screw (20) resp. on the drive sleeve (21). If not, the seal rings may break during the continued assembly.

2

Lubricate O-rings with a food grade silicone lubricant before fitting.

4

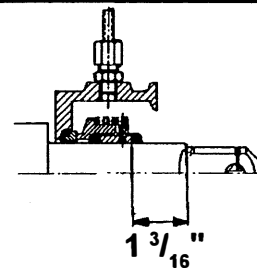

1. Push seal housing (17) with O-ring (23a) and stationary seal ring (28a) (sealing surface towards the pump) onto shaft (15).
2. Push the rotating seal ring (25a) and O-ring (24a) onto the shaft.
3. Place drive sleeve (21) on pump shaft with set screw (20) towards motor. Adjust so that distance from front of drive sleeve to recess on pumpshaft is $1 \frac{3}{16}$ ". Tighten driver sleeve set screw (20) through a hole for flushing water.

6

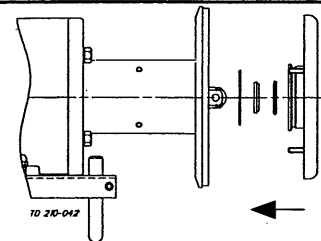

1. Lubricate and fit O-ring (27) in the seal housing.
2. Place O-ring (23b) and stationary seal ring (28b) in backplate (9).
3. Push the back-plate with stationary seal ring and O-ring carefully over the shaft with seal parts.

NOTE!

Be very careful so that the pin on the drive sleeve enters into the notch in the seal ring check immediately. Force applied to the back plate can otherwise break the rotating seal ring.

Read the instructions carefully.
The items refer to the drawings and the parts list on the pages 22-26.

Lubricate the rubber seals before fitting them.

3. Assembly of Pump/Fitting the Double Shaft Seal

19

7

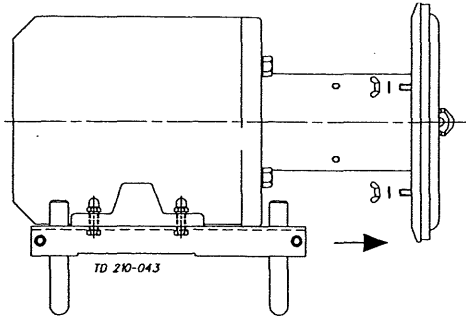

Tighten the back plate with three wing nuts (14) and spring washers (13).

8

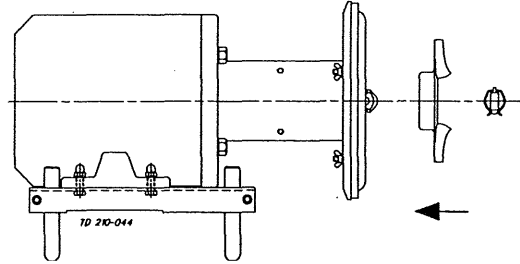

1. Fit impeller (11) on shaft.
2. Insert pin (10) with clip in the hole at the shaft end and press the clip into the groove in the shaft.

9

Use depth gauge to check clearance between impeller and backplate. Proper clearance should be 0.02". Tighten the three shaft set screws (16) on shaft (15). Be careful so that the shaft does not move axially while being tightened.

10

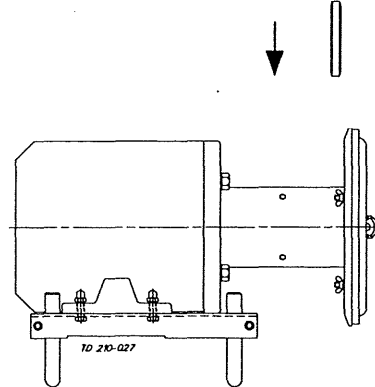

Assemble the seal housing (17) and backplate (9) with clamp (22) carefully, so that the set screw enters into the notch on the rotating seal ring (25).

11

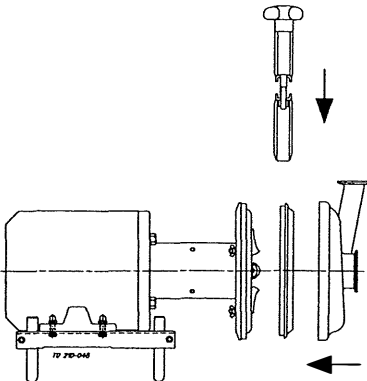

1. Lubricate and fit casing gasket (8). Fit pump casing (12) and clamp (7).
2. Tighten the clamp to metallic contact casing/adaptor.

NOTE:

An incorrectly fitted clamp can cause serious damage.

12

Check by turning the shaft that the impeller moves freely.



Maintenance

Read the instructions carefully.
The items refer to the drawings and the parts list on the
pages 22-26.

Lubricate the rubber seals before fitting them.

3. Assembly of Pump/Fitting the Double Shaft Seal

13

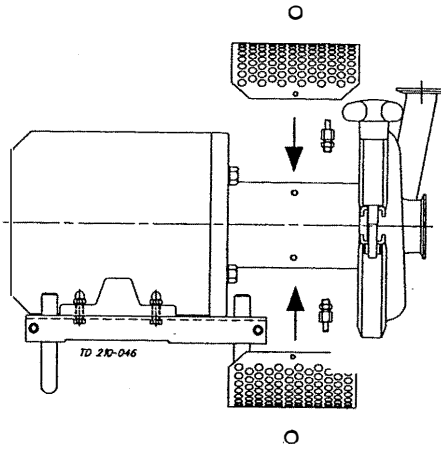

1. Fit seal-flushing water connections (18,19).
2. Install OSHA shields (5) using screws (6)

It is important to observe the technical data during installation, operation and maintenance. Inform the personnel about the technical data.

1. Technical Data

Data

Max. inlet pressure	60 PSI (4 bar)
Max. outlet pressure	174 PSI (12 bar)
Temperature range	+14°F to +284°F (EPDM)

Materials

Product wetted steel parts	AISI 316L
Other steel parts	AISI 304
Adaptor	Cast iron, zinc sprayed and coated with two-component lacquer
Product wetted seals	EPDM (standard)
Other seals	EPDM
Alternative seals	FPM, and Nitrile (NBR)
Finish	150 grit polish

Shaft Seal

Seal types	Mechanical single or double
Max. water pressure (flushed seal)	Normally atmospheric (max. 14.5 PSI)
Water consumption (flushed seal)	4-8 Gal/hr
Material, stationary seal ring	Silicon carbide
Material, rotating seal ring	Carbon (standard) and Silicon Carbide
Material, O-rings	EPDM (standard)
Alternative material, O-rings	FPM, and Nitrile (NBR)

Motor

Standard C-faced foot mounted motor according to NEMA standard, 3600/1800 RPM 60HZ, 3 phase.

Voltage and frequency	60 Hz, 230-460V Std.
-----------------------------	----------------------

Motor sizes (HP), 60 Hz	1/2, 3/4, 1, 1 1/2, 2, 3, 5, 7 1/2, 10, 15, 20, 25, 30, 40.
-------------------------------	---

* Other voltage and frequencies available upon request.



Exploded Drawing

This page shows an exploded drawing of GHC -1,-2,-3, with single shaft seal.

The drawing includes all items of the pump. They are identical with the items in the Spare Parts List.

GHC -1, -2, -3, Single shaft seal

22

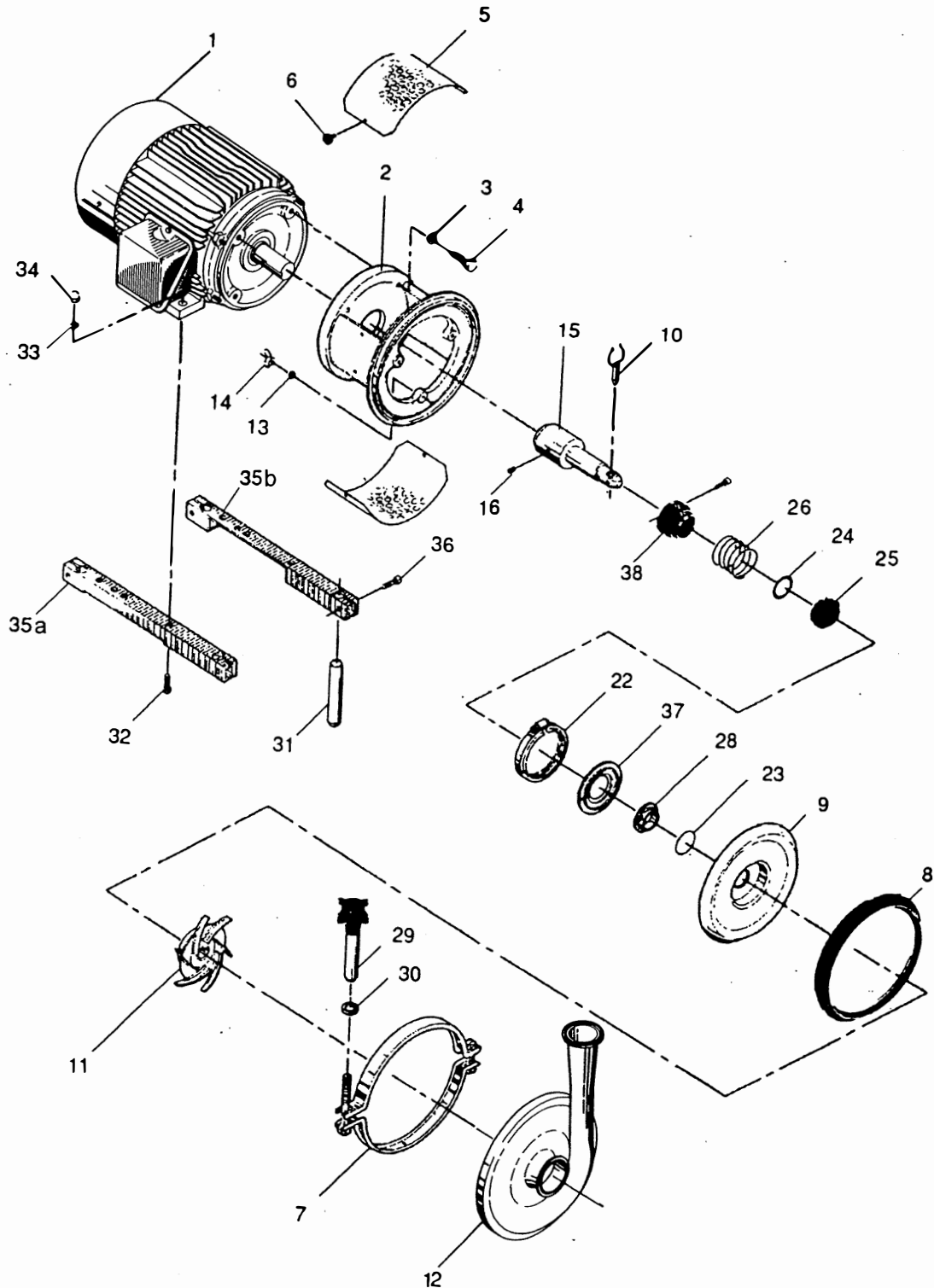

CSI

CONTACT CSI FOR MORE INFORMATION | CSIDESIGNS.COM | SALES@CSIDESIGNS.COM | 417.831.1411

This page shows an exploded drawing of GHC -1,-2,-3, with double shaft seal.

The drawing includes all items of the pump. They are identical with the items in the Spare Parts List.

GHC -1, -2, -3, Double Shaft Seal

23

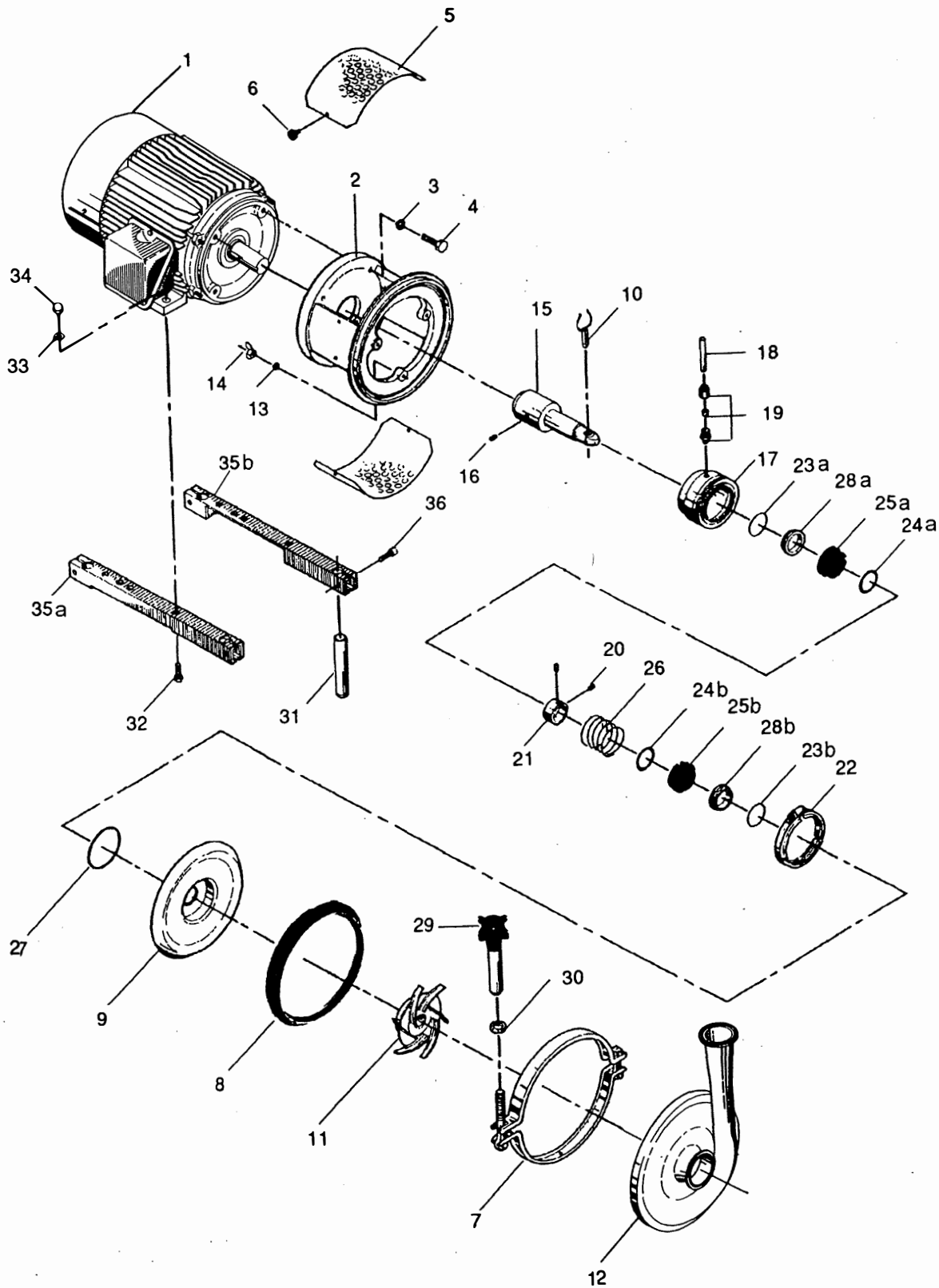

Drawing/Parts List

The drawing shows GHC.

The items refer to the parts list on page 26.

24

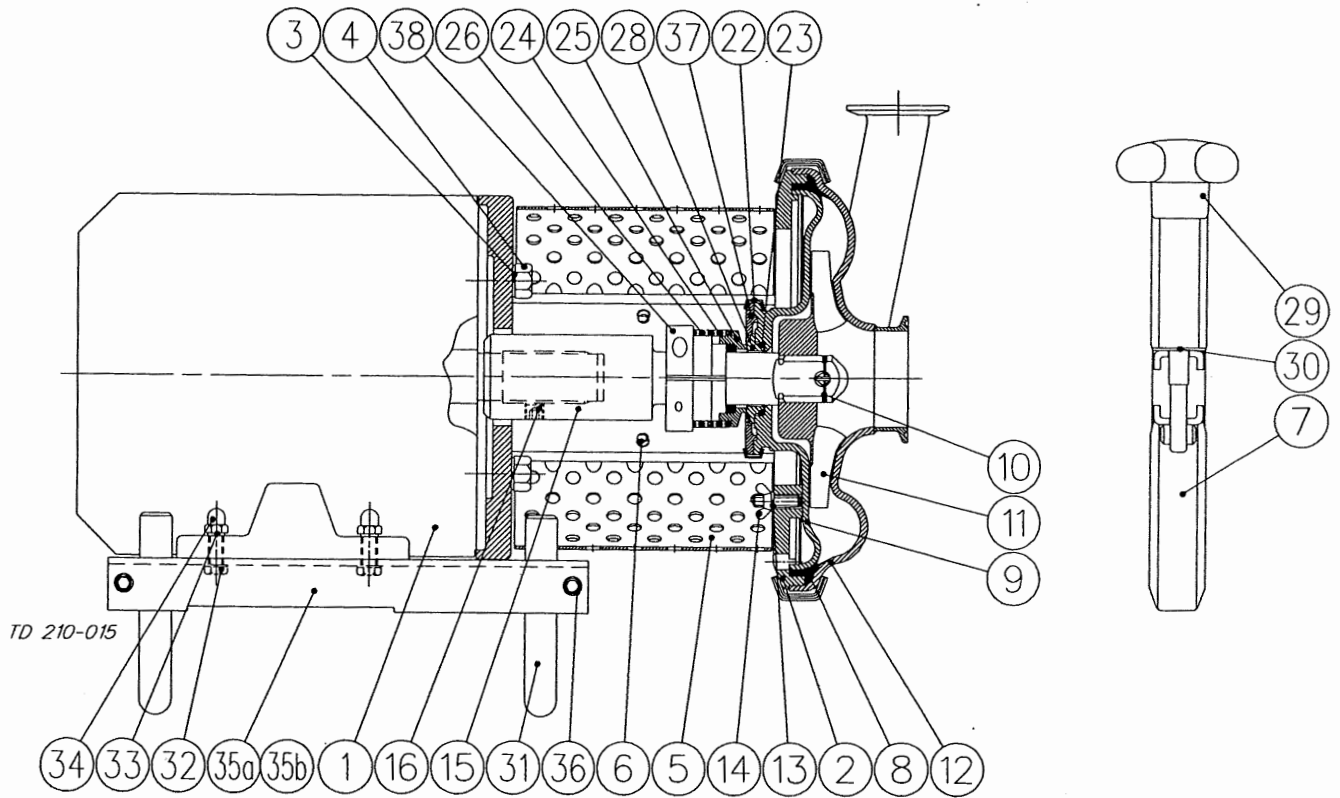

Single shaft seal



CSI

CONTACT CSI FOR MORE INFORMATION | CSIDESIGNS.COM | SALES@CSIDESIGNS.COM | 417.831.1411

The drawing shows GHC.

The items refer to the parts list on page 26.

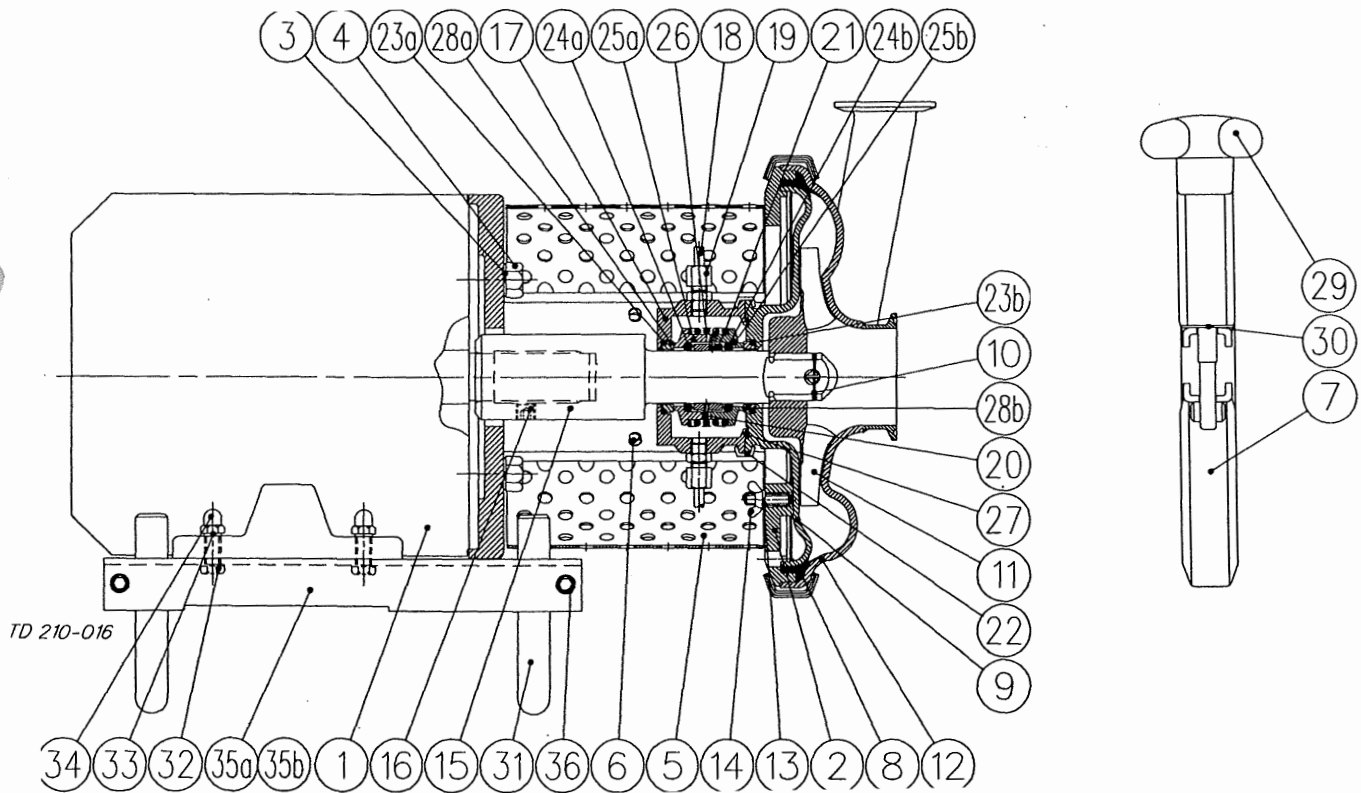

Double shaft seal



The drawing and the parts list include all items of the pump. The items are identical with the items in the Spare Parts List.
When ordering spare parts, please use the Spare Parts List!

26

Parts List

Item	Qty.	Description
1	1	Motor
2	1	Adaptor
3	4	Spring washer
4	4	Screw
5	2	OSHA-shield (GHC-1 only)
6	4	Screw (GHC-1 only)
7	1	Hinge clamp
8Δ	1	Casing gasket
9	1	Backplate
10	1	Impeller pin
11	1	Impeller
12	1	Pump casing
13	3	Spring washer
14	3	Wingnut
15	1	Shaft
16	3	Shaft set screw
17□	1	Seal housing
18□	2	Copper pipe
19□	2	Fitting
20□	1	Drive sleeve set screw
21□	1	Drive sleeve
22	1	Clamp
23*Δ	1	Stationary O-ring
23ab□Δ	2	Stationary O-ring
24*Δ	1	Rotary O-ring
24ab□Δ	2	Rotary O-ring
25*Δ	1	Rotary seal ring
25ab□Δ	2	Rotating seal ring
26	1	Spring
27□Δ	1	Housing O-ring
28*Δ	1	Stationary seal ring
28ab□Δ	2	Stationary seal ring
29	1	Handle
30	1	Washer
31	4	Pump leg
32	4	Mounting bolt
33	4	Lock washer
34	4	Acorn cap nut
35a	1	Pump support bar, right
35b	1	Pump support bar, left
36	4	Screw
37*	1	Retaining ring
38*	1	Adjusting collar

- Δ : Service kit - EPDM, FPM and NBR
(See Spare Parts List)
□ : Flushed shaft seal only
* : Single shaft seal only



CSI

This page may be used for notes concerning the normal handling of the pump.

The best way to produce user-friendly manuals is through feedback from the user.
- Please see below.

1. Notes

for PUMP MADE IN 1986

GHC/3	SHAFT SEAL KIT	2700831	177 ⁰⁰	-	11-28-01	EPDM
	JOINTRING	3146000091	56 ⁰⁰	-	"	
	STUB SHAFT (20HP)	3146010871	482 ⁰⁰	-	1987	
	SHAFT SEAL KIT (EP, TY, D.)	2700821	280 ⁰⁰	-	TYPE D - ULLU STYLE	

27

Any pumps after 1987 use TYPE 'D' STYLE SEAL whole different SEAL configuration after 84

2. User feedback

Our goal is to produce instruction manuals that meet your needs. If you have any comments which may help us in our efforts to improve this manual, please do not hesitate to send them to us.
G&H Products Corp.

Please write to:



Thank you!

Tel. 800-558-4060
Fax. 414-947-4724