

# Tri-Flo<sup>®</sup> Air-Actuated Valves

Series 361 • 361TR • 371

Service & Installation Manual



**Tri-Clover Inc.**



# CONTENTS

Thank you for purchasing a Tri-Clover Product!

This manual contains disassembly and assembly instructions, maintenance procedures, troubleshooting, and a complete parts list for all Series 361, 361TR, and 371 Air-Actuated Valves and actuators designed and manufactured by Tri-Clover Inc., Kenosha, Wisconsin.

**READ THIS MANUAL** carefully to learn how to service these valves. Failure to do so could result in personal injury or equipment damage.

## SAFETY

IMPORTANT SAFETY INFORMATION .....	4
------------------------------------	---

## MAINTENANCE

VALVE DISASSEMBLY .....	5
VALVE INSPECTION .....	6
VALVE ASSEMBLY .....	7
TR STEM/SEAT PLUG ASSEMBLY FOR 361/361TR .....	8
TYPE 210 AND 220 ACTUATORS .....	9
TYPE 213 AND 223 ACTUATORS .....	12
TYPE 280 ACTUATOR .....	16
TYPE 215 ACTUATOR .....	18

## PARTS LIST

361/361TR SHUT OFF VALVES .....	22
371-10, 30, 27 THROTTLING VALVE .....	22
361/361TR DIVERT VALVES .....	24
371-21 THROTTLING DIVERT VALVE .....	24



# SAFETY

## IMPORTANT SAFETY INFORMATION

Safety is very important!

**DO NOT attempt to modify any Tri-Clover product.** To do so could create unsafe conditions and void all warranties. **DO NOT place any Tri-Clover product in an application where general product service ratings are exceeded.**

The following DANGER, WARNING, AND CAUTION signs and their meanings are used within these instructions.

	<b>⚠ DANGER</b>
	Indicates an imminently hazardous situation which, if not avoided, <b>will</b> result in death or serious injury. The word Danger is used in the most extreme cases.

	<b>⚠ WARNING</b>
	Indicates a potentially hazardous situation which, if not avoided, <b>may</b> result in minor or moderate injury. May also be used to alert against an unsafe operating or maintenance practice.

	<b>⚠ CAUTION</b>
	Indicates a potentially hazardous situation which, if not avoided, <b>could</b> result in death or serious injury.

The SAFETY LABELS below are placed on every valve. Do not remove any labeling on any Tri-Clover product. Immediately replace any label that is missing.



Part Number  
38-294

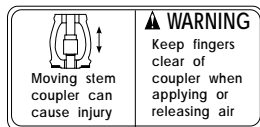

Part Number  
38-297



Part Number 38-264

# MAINTENANCE

## VALVE DISASSEMBLY



### **WARNING**

To prevent personal injury, keep hands and tools away from valve coupler, bodies and stems when applying or releasing actuator air supply. The actuator stem assembly moves with extreme force and suddenness when air pressure is applied or released.

When disassembling and assembling a valve, the bench area should be clean to prevent marring and nicking of seats.

#### **NORMALLY OPEN: TYPE 210, 280 AND 215 ACTUATORS**

1. Remove body clamp, lower body and gasket.
2. Apply air to actuator so the valve stem extends away from the actuator and off its upper seat.
3. Lift sleeve on coupling unit and remove valve stem by pulling it through the bonnet/upper body.
4. Remove actuator clamp and separate the actuator from the open yoke.
5. Remove air supply.

#### **NORMALLY CLOSED: TYPE 220 AND 225 ACTUATORS**

1. Apply air to actuator so the valve stem retracts towards the actuator and off its lower seat.
2. Remove body clamp, lower body and gasket.
3. Release air supply.
4. Lift sleeve on coupling unit and remove valve stem by pulling it through the upper body/bonnet.
5. Remove actuator clamp and separate the actuator from the open yoke.

# MAINTENANCE

## VALVE INSPECTION

### STEM & SEAT(S)

Carefully examine the rubber or PTFE valve plug seats for cracking, tearing, checking or excessive wear. Leakage past the seat(s) may result from these types of irregularities.

**Note:** Refer to the *TR Stem/Seat Plug Assembly for 361/361TR* section for installation of TR seats.

### SURFACE FINISH

Inspect the valve stem and its bore in the valve upper body or bonnet for signs of galling. Replace both components if galling exists. Galling will continue to occur if only one part is replaced and the other is damaged.

### VALVE BODY

Inspect the valve seats for nicks, scratches and other irregularities. Leakage past the seats may result from these types of irregularities.

### COUPLER

Check the coupler to see that three balls are in place and move freely when the coupler sleeve is raised. If coupler replacement is required see the *Type 210/220 Actuator section* in this manual.

### GASKETS & O-RING(S)

Inspect for cuts, abrasions, flat spots or other damage that would cause leakage or ineffective cleaning. Replace as necessary.

# MAINTENANCE

## VALVE ASSEMBLY



### **WARNING**

To prevent personal injury, keep hands and tools away from valve coupler, bodies and stems when applying or releasing air supply. The actuator stem assembly moves with extreme force and suddenness when air pressure is applied or released.

When disassembling and assembling a valve, the bench area should be clean to prevent marring and nicking of seats.

### **NORMALLY OPEN: TYPE 210, 280 AND 215 ACTUATORS**

1. Clamp actuator to upper body/bonnet with actuator clamp.
2. Install o-ring on valve stem.
3. Apply air supply to actuator so the coupler extends away from the actuator.
4. Lift sleeve on coupling unit and insert stem into coupling unit. Release coupling sleeve.
5. Release air supply.
6. Replace gasket, lower body and body clamp.

### **NORMALLY CLOSED: TYPE 220 AND 225 ACTUATORS**

1. Clamp actuator to upper body/bonnet with actuator clamp.
2. Install o-ring on valve stem.
3. Lift sleeve on coupling unit, insert valve stem into coupling unit and release sleeve.
4. Apply air to actuator so the coupler retracts towards the actuator.
5. Replace gasket lower body and body clamp.
6. Release air supply.

# MAINTENANCE

## TR STEM/SEAT PLUG ASSEMBLY FOR 361/361TR

### REMOVAL OF PTFE SNAP-ON SEAT

1. Refer to the *Disassembly* section to remove stem/seat assembly from valve.
2. Using a knife, partially cut through the upper ring portion of Snap-On Seat, avoiding contact with stainless steel stem. Grasp both cut ends of Snap-On Seat and force apart for removal from stem.

Cut here  
to remove  
seat.

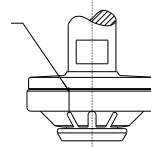

### INSTALLATION OF REPLACEMENT PTFE SNAP-ON SEAT

Tri-Clover's replacement Snap-On Seats do not require heat or special tools for proper installation. Snap-On Seats are installed by applying uniform pressure on all sides. Pressure can be applied by using a Tri-Clamp® or Bevel Seat ferrule the same size as the valve.

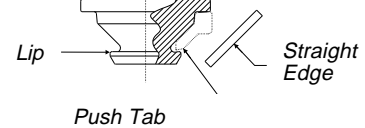

### SHUT OFF VALVE OR LOWER SEAT OF DIVERT VALVE

1. Place Snap-On Seat on the lower portion of the stem.
2. Place assembly from Step 1 on Tri-Clamp® or Bevel Seat ferrule, resting on a hard flat surface such as a bench or table.
3. Apply firm, even, downward pressure on the stem until the Snap-On Seat hits the shoulder of the stem and snaps into place.
4. Examine seat assembly to be sure each individual tab is secure under the smaller lip portion of the stem. Press tabs down with your fingers or a straight edge. Holding Stem/Seat Assembly in one hand, rotate the Snap-On Seat. For proper CIP cleaning, the seat should turn freely on the stem.
5. Refer to *Valve Assembly* section for reassembly.

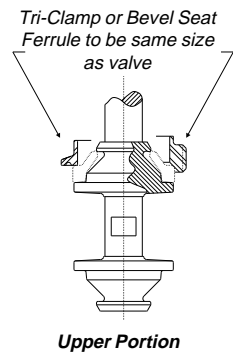
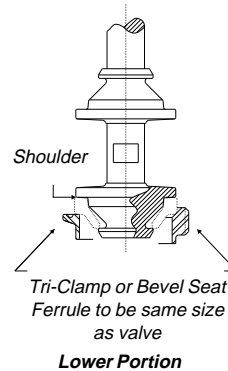

U.S. Patent No. 4,531,532

### UPPER SEAT OF DIVERT VALVE

1. Place Snap-On Seat on the upper portion of the stem.
2. Place Tri-Clamp® or Bevel Seat ferrule on top of assembly, resting on a hard, flat surface such as a bench or table.
3. Apply firm, even, downward pressure on Tri-Clamp® or Bevel Seat ferrule until Snap-On Seat hits the shoulder of the stem and snaps into place.
4. Examine Seat Assembly to be sure individual tab is secure under the smaller lip portion of the stem. Press tabs down with your fingers or a straight edge. Holding Seat Assembly in one hand, rotate the Snap-On Seat. For proper CIP cleaning, seat should turn freely on the stem.
5. Refer to valve assembly section for reassembly.



# MAINTENANCE

## TYPE 210 AND 220 ACTUATORS

### INTRODUCTION

The 210 and 220 actuators are spring return units used when a normally open or normally closed valve is required. The actuators contain identical components but are assembled differently for each type of operation.

### INSTALLATION

Connect air supply to the quick coupler fitting or the  $\frac{1}{8}$ "-27 FNPT port it is screwed into. Air supply specifications: 35-50 psig. Refer to table on next page if additional product holding pressure is required on normally closed Type 20 actuators.

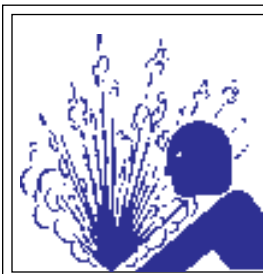

### ⚠ WARNING

To prevent personal injury, do not attempt to repair an old style actuator. The old style actuator has a preloaded spring which will eject from the actuator body with sufficient force to cause serious injury to anyone in the immediate area. An old style actuator has no "step" between cylinder and bonnet. See right.

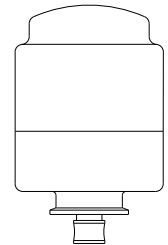

OLD (No Step)



### ⚠ WARNING

To prevent personal injury, hand pressure should be applied to the top of the cylinder and bonnet. The actuator cylinder may eject with sufficient force to cause serious injury. Remove actuator from valve before disassembling actuator. On 1" size valves, the actuator spring is not contained. Caution should be used when the spring force is released.

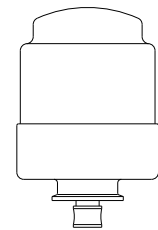

NEW (Step)

### ACTUATOR DISASSEMBLY

1. Place the two flats on the actuator bonnet in a vise. This will prevent the actuator bonnet from turning when removing the actuator cylinder.
2. Remove actuator cylinder from bonnet by applying a strap wrench to the cylinder and turning in a counterclockwise direction until cylinder and bonnet can be separated.
3. Slide the cylinder off of the piston.
4. Remove the spring from the piston. (*220 actuator only*).
5. Remove the actuator stem nut and lockwasher. To prevent the stem from rotating, apply a wrench to the stem flat above the coupler.
6. Slide the piston and spring (*210 only*) off the actuator stem and remove the bonnet from the vise.
7. Remove the actuator stem from the bonnet.
8. Remove the actuator stem o-ring.
9. Remove the coupler from the actuator stem by applying wrenches to the flats on both parts. Turn the coupler counterclockwise.

# MAINTENANCE

## ACTUATOR REASSEMBLY

1. If the bushing in the bonnet has been removed, install a new retaining ring and packing. Press a new bushing into the bonnet until it is firmly seated. Be sure the packing is installed with vee opening away from the bushing.
2. Install cylinder o-ring seal in the bonnet below the thread.
3. Attach coupler to actuator stem and insert stem in the bushing. Check the clearance between the stem and the bushing. Ream the bushing if necessary until the stem travels freely in the bore.
4. Replace the o-ring on the actuator stem.
5. Install new packings on the piston if required.
6. Be sure upper packing lip is facing toward the top of the piston, and the lower packing lip is toward the bottom of the piston.
7. Apply a suitable food grade lubricant to packings and felt seal prior to installation on the piston.
8. Install the spring and piston.

### ***Type 210 (Normally Open)***

- Place the spring into the bonnet with the small retainer diameter up.
- Place the piston over the spring with the counter bore down.
- Install the lockwasher and nut and tighten to 20 ft.-lb.

### ***Type 220 (Normally Closed)***

- Place the piston into the bonnet with the counter bore down.
  - Install the lockwasher and nut and tighten to 20 ft.-lb.
  - Place the spring into the piston counter bore with its small retainer diameter facing up.
9. Lubricate inside wall of cylinder with OCP-VI and slide the cylinder over the piston. Use shim stock or a thin flat tool to compress the upper packing on the piston to get it started in the cylinder.
  10. Lubricate the cylinder threads with Tri-Clover C137 lubricant. This will prevent the stainless steel threads from galling.
  11. Thread the cylinder into bonnet and tighten it until it bottoms. It will be necessary to use a strap wrench for the last few turns as the spring is being compressed approximately  $\frac{1}{8}$  inch.

## TO CONVERT A TYPE 210 ACTUATOR TO A TYPE 220 ACTUATOR

1. Remove the cylinder, actuator stem, nut and lockwasher, piston and spring as outlined in the *Disassembly* instructions.
2. Reassemble as outlined in step #8 through #11 in the *Actuator Reassembly* section.

### IMPORTANT:

Additional air supply must be relieved when product pressure is not present. Failure to do so will result in pressure damage to the seat.

When using additional air loading it should exceed the minimum required by no more than 1 to 5 psig to minimize seat loading.

Valve Size	*Add'l Air Pressure	Add'l Air Pressure Maximum	Maximum Product Holding Pressure
1	1	10	200
1½	1	5	200
2	2	12	150
2½	3	15	100
3	4½	30	100
4	15	0	100

Air pressure measured in psig.

\*Additional air pressure required to hold against 10 psig product pressure

# MAINTENANCE

## PARTS LIST: TYPE 210 & 220 ACTUATORS

Key #	Description	Part Number	No. Req.
1	Actuator body cylinder	25-361-210-01-S	1
2	Vented plug	MS-105-58A-CP	1
3	Nut	NU1700H-SS	1
4	Lockwasher	LWA1700-SS	1
5	Piston	25-361-210-02	1
*6	Vee block packing	17-97	2
*7	Felt seal	17-101	1
8	Spring assembly	25-361-210-07-S	1
*9	O-ring	10CPLO-3-73-1A-U	1
10	Bonnet	25-361-210-03-S	1
11	Air Coupler adapter	25-361-210-06-S	1
*12	Retaining ring	16-70	1
*13	Vee block packing	17-98	1
*14	Bushing	40-4	1
*15	O-ring	17-35-U	1
16	Actuator stem	25-361-210-09A-01-S	1
*17	Coupler	37-95A-SS	1

\* It is recommended that one spare part be stocked for each item marked with the exception of item 6, in which case two spares should be stocked.

**Note:** Tri-Clover recommends the following lubricants for servicing stainless steel actuators: C137 for the cylinder threads, and OCP-VI lubricant for all other lubricated areas.

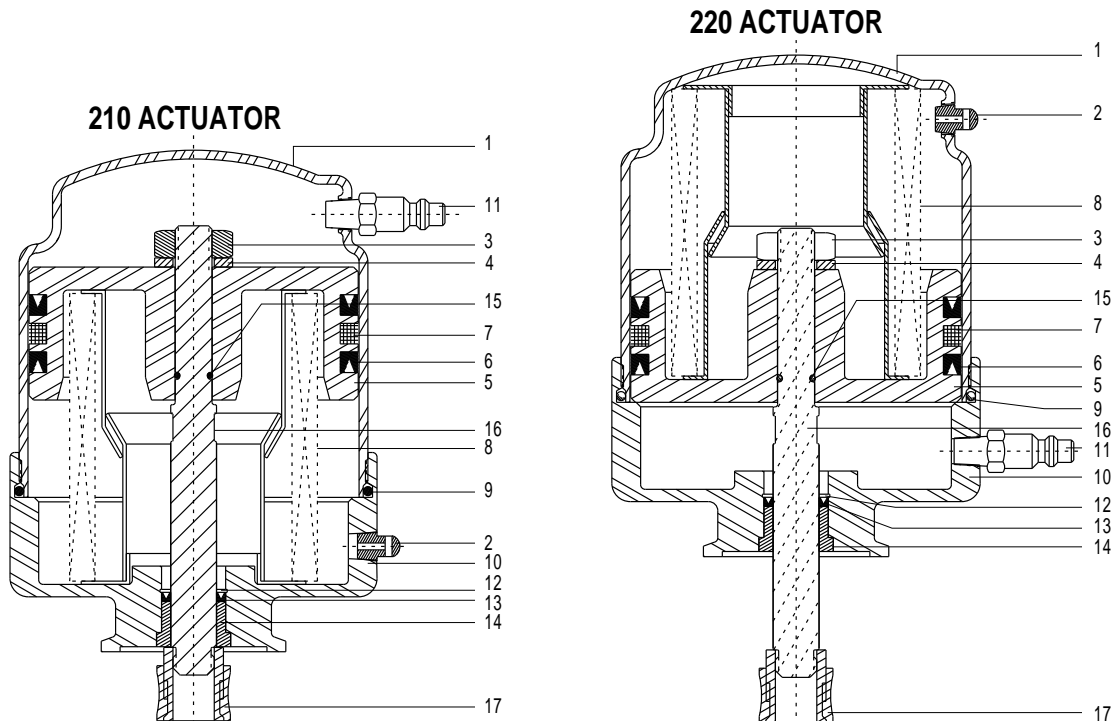

# MAINTENANCE

## TYPE 213 AND 223 ACTUATORS

### INTRODUCTION

The 213 and 223 actuators are spring return units used when a normally open or normally closed valve is required with position indication feedback. Both actuators contain identical components but are assembled differently for each type of operation.

### INSTALLATION

Connect air supply to the quick coupler fitting or the 1/8-27 FNPT port it is screwed into. Air supply specifications: 35-50 psig. Additional Air Supply Guidance. Refer to table below if additional product holding pressure is required on normally closed Type 23 actuators.

	<p><b>⚠ DANGER</b></p> <p>To prevent personal injury or death by electrical shock, disconnect power to all electrical devices and panels before performing any service. All service should be performed by a qualified electrician.</p>
---	---

	<p><b>⚠ WARNING</b></p> <p>To prevent personal injury, do not attempt to repair an old style actuator. The old style actuator has a preloaded spring which will eject from the actuator body with sufficient force to cause serious injury to anyone in the immediate area. An old style actuator has no "step" between cylinder and bonnet. See right.</p>
--	---

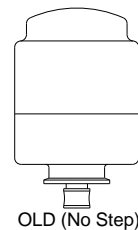

	<p><b>⚠ WARNING</b></p> <p>To prevent personal injury, hand pressure should be applied to the top of the cylinder and bonnet. The actuator cylinder may eject with sufficient force to cause serious injury. Remove actuator from valve before disassembling actuator. On 1" size valves, the actuator spring is not contained. Caution should be used when the spring force is released.</p>
---	---

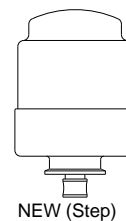

# MAINTENANCE

## DISASSEMBLY

1. Place the two flats on the actuator bonnet in a vise. This will prevent the actuator bonnet from turning when removing the actuator cylinder.
2. Remove the acorn nut and plastic washer from top of the switch housing.
3. Grasp the housing and rock slightly while pulling it off its mount to the actuator. It is held in place by an o-ring.

**Important:** The housing will still be connected to the switches between the cable cord grip and cable strap fastened to the switch mounting bracket. There is a sufficient length of cable inside the housing to lift it away and expose all the switches and connections, but it cannot be completely removed at this point.

4. Disconnect the white plastic connectors from the switches. Unfasten the cable strap and ground wire from the mounting bracket. The switch housing can now be removed.
5. Remove the switch mounting screws completely and remove the switches and adjustment plates.
6. Remove actuator cylinder from bonnet by applying a strap wrench to the cylinder and turning in a counterclockwise direction until cylinder and bonnet can be separated.
7. Slide the cylinder off the piston and remove the o-rings from the switch mounting base.
 

**Note:** It is not necessary to remove the switch mounting base and bracket from the cylinder unless the cylinder is damaged.
8. Remove the spring from the piston. (*Type 223 only*)
9. Remove the switch activating stem, actuator stem nut and lockwasher. To prevent the stem from rotating, apply a wrench to the stem flat above the coupler.
10. Slide the piston and spring (*Type 213 only*) off the actuator stem and remove the bonnet from the vise.
11. Remove the actuator stem from the bonnet.
12. Remove the actuator stem o-ring.
13. Remove the coupler from the actuator stem by applying wrenches to the flats on both parts. Turn the coupler counterclockwise.

### IMPORTANT:

Additional air supply must be relieved when product pressure is not present. Failure to do so will result in pressure damage to the seat.

When using additional air loading it should exceed the minimum required by no more than 1 to 5 psig to minimize seat loading.

Valve Size	*Add'l Air Pressure	Add'l Air Pressure Maximum	Maximum Product Holding Pressure
1	1	10	200
1½	1	5	200
2	2	12	150
2½	3	15	100
3	4½	30	100
4	15	0	100

Air pressure measured in psig.

\*Additional air pressure required to hold against 10 psig product pressure

# MAINTENANCE

## ACTUATOR REASSEMBLY

1. If the bushing in the bonnet has been removed, install a new retaining ring and packing. Press a new bushing into the bonnet until it is firmly seated. Be sure the packing is installed with vee opening away from the bushing.
2. Install the o-ring in the bonnet below the thread for the cylinder.
3. Attach coupler to actuator stem and insert stem in the bushing. Check the clearance between the stem and bushing. Ream the bushing if necessary until the stem travels freely in the bore.
4. Replace the o-ring on the actuator stem.
5. Install new packings on the piston if required.
6. Be sure upper packing lip of the upper packing is toward the top of the piston, and the lower packing lip is toward the bottom of the piston.
7. Apply a suitable food grade lubricant to packings and felt seal prior to installation on the piston.
8. Install the spring and cylinder.

### Type 213 (Normally Open)

- Place the spring into the bonnet with the small retainer diameter up.
- Place the piston over the spring with the counter bore down.
- Install the lockwasher and nut and tighten to 20 ft.-lb.
- Install the activating stem into the actuator stem.

### Type 223 (Normally Closed)

- Place the piston into the bonnet with the counter bore down.
- Install the lockwasher and nut and tighten to 20 ft.-lb.
- Install the activating stem into the actuator stem.
- Place the spring into the piston counter bore with its small retainer diameter facing up.

9. Replace the two o-rings in the switch mounting base bore and lubricate with L-1011B.
10. Lubricate cylinder inside wall with OCP-VI. Slide the cylinder over the piston and activating stem. Use a shim stock or a thin flat tool to compress the upper packing on the piston to get it started into the piston.
11. Lubricate the cylinder threads with Tri-Clover C137 lubricant. This will prevent the stainless steel threads from galling.
12. Thread the cylinder into bonnet and tighten it until it bottoms. It will be necessary to use a strap wrench for the last few turns.
13. Mount the switches to the mounting bracket by threading the screws into the adjustment plates.
14. Connect the white plastic connectors to the switches. Fasten the ground wire eyelet to the mounting bracket.
15. Leave approximately 6" of cable between the cable strap fastened to the mounting bracket and the cable grip in the housing.
16. Install the actuator to the valve assembly.
17. **Important:** Switches must be set when the valve is completely assembled. Set the switches.
  - Locate the lower switch roller in the middle of the activating stem groove when the activating stem is all the way extended.
  - Locate the upper switch at the top of the activating stem, when the stem is all the way retracted.
18. Place the housing over switch base o-ring. Place plastic washer over the stud extending from the housing and tighten securely with the acorn nut.

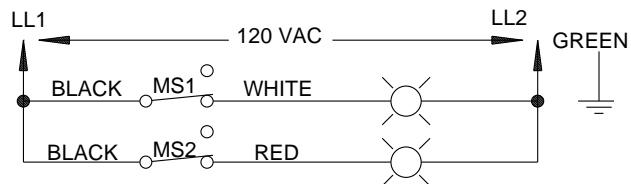

**Wiring Schematic**

Normally Open contact closes to verify valve position

# MAINTENANCE

## PARTS LIST: TYPE 213 & 223 ACTUATORS

Key #	Description	Part Number	No. Req.
1	Actuator Body Cylinder	25-361-213-01-S	1
2	Vented Plug	MS-105-58A-CP	1
3	Nut	NU1700H-SS	1
4	Lockwasher	LWA1700-SS	1
5	Piston	25-361-210-02	1
*6	Vee Block Packing	17-97	2
*7	Felt Seal	17-101	1
8	Spring Assembly	25-361-210-07-S	1
*9	O-ring	10CPLO-3-73-1A-U	1
10	Bonnet	25-361-210-03-S	1
11	Air Coupler Adapter	25-361-210-06-S	1
*12	Retaining Ring	16-70	1
*13	Vee Block Packing	17-98	1
*14	Bushing	40-4	1
*15	O-ring	17-35-U	1
16	Actuator Stem	25-361-213-09A-01-S	1
*17	Coupler	37-95A-SS	1
18	Gasket	17-306-U	1
19	Switch Assembly Base	26-42	1
20	O-ring	17-156-U	1
21	#6-32 x 3/8 LG. Truss HD-SS	SC505Y-SS	3
22	Switch Mounting Bracket	10-155	1
23	#4-40 x 1" LG. RD. HD. Mach. Screw	SC110R-SS	4
24	Micro-Switch	EL-79500-0013	2
25	Socket	EL-19760-0011	2
26	Cover Hold Down Bracket	10-154	1
27	Switch Cover	23-124-1-S	1
28	Nylon Lockwasher	15-87-3/8	1
29	Acorn Nut 3/8-16-SS	13-60-3/8-S	1
30	Nut	13-88-S	1
31	Lockwasher	15-119	1
32	O-ring	17-35-U	2
33	Indicating Stem	25-361-213-19A-S	1
34	Switch Adj. Plate	10-156-S	2
35	#10-32 x 1/4" LG. RD. HD. Mach. Screw	SC1003R-SS	2
36	#10 Lockwasher	LWA900-SS	2
37	Cable Assembly	EL-97510-0004	1
38	Rubber Grommet	EL-40165-0004	1
39	Knurled Nut	EL-40165-0011	1
40	Cable Clamp	16-115	1
41	Switch Mounting Block	24-30	2
42	O-ring	17-157-U	1
43	Washer	15-110	1

\* It is recommended that one spare part be stocked for each item marked with the exception of item 6, in which case two spares should be stocked.

**Note:** Tri-Clover recommends the following lubricants for servicing stainless steel actuators: C137 for the cylinder threads, and OCP-VI lubricant for all other lubricated areas.

213 ACTUATOR (FRONT VIEW)

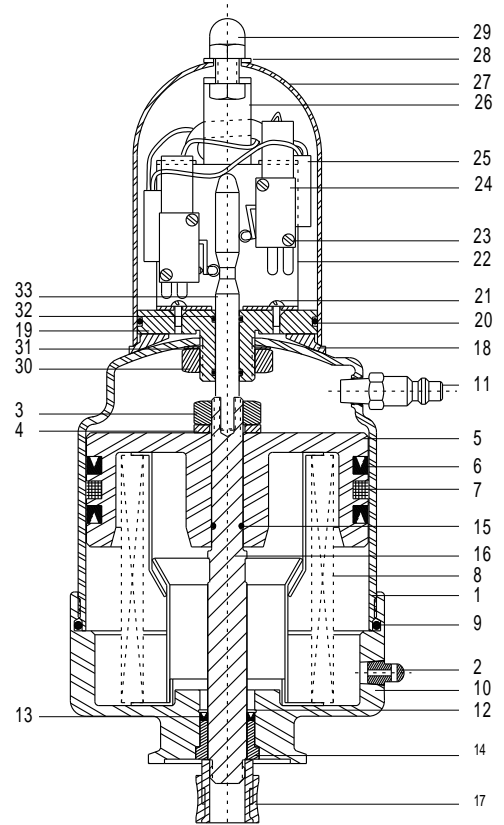

213 ACTUATOR (SIDE VIEW)

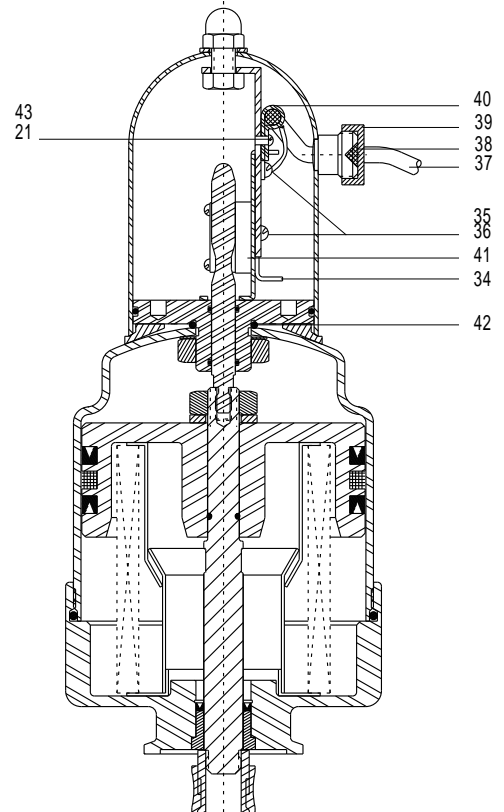

# MAINTENANCE

## TYPE 280 ACTUATOR

### INTRODUCTION

The Type 280 is a three position actuator. It is a normally open actuator which can partially or fully close with two independent air supplies.

### INSTALLATION

Connect air supplies to quick coupler fitting or the 1/8-27 FNPT port it is screwed into. Air supply specifications: 35-50 psig.

For regular open and closed operation, apply air to the top air connection. This will fully close the valve bottom port. Release the air supply to fully open the valve bottom port.

For immediate, split flow or dribble feed operation, apply air to the side air connection. This will position for split flow or dribble feed operation depending on how the actuator is adjusted. Adjust the mid position as follows:

1. Loosen the jamnut on top of the actuator.
2. Use a wrench on the air coupler hex fitting and rotate the complete air guide stem.
3. Turn clockwise to give more restriction to the valve bottom port.
4. Turn counterclockwise to give more restriction to the top port.

**Note:** Use two 3-way solenoid valves to control air to the above connections.

	<p style="text-align: center;"><b>⚠ WARNING</b></p> <p>To prevent personal injury, hand pressure should be applied to the top of the cylinder and bonnet. The actuator cylinder may eject with sufficient force to cause serious injury. Remove actuator from valve before disassembling actuator.</p>
---	--

### ACTUATOR DISASSEMBLY

1. Secure the two flat edges on the actuator ferrule in a vise. This will keep the bonnet from turning when removing the actuator.
2. Remove the actuator cylinder from the bonnet by applying a strap wrench to the cylinder and turning counterclockwise. Separate the cylinder from the bonnet. Slide the cylinder off of the piston.
3. Use suitable wrenches on the machined flats of the coupler to remove the stem nut and lockwasher on the top of the piston.
4. Slide the piston and spring off the bonnet. Remove the bonnet from the vise.
5. Remove the actuator stem from the bonnet. Remove the bonnet o-ring and the actuator o-ring.
6. Use suitable wrenches to remove the coupler from the actuator stem.
7. Remove the jamnut on top of the cylinder.
8. Remove the air guide stem by rotating counterclockwise and removing from inside the cylinder.
9. Slowly slide the secondary piston out of the cylinder.

**Note:** It is not necessary to remove the mounting nut or bolt unless there is a leak in this area.



# MAINTENANCE

## ACTUATOR REASSEMBLY

1. If the bushing in the bonnet has been removed, install a new retaining ring and packing. Press a new bushing into the bonnet until it is firmly seated. Be sure the packing is installed with the vee opening away from the bushing.
2. Attach the coupler to the actuator stem and insert the stem through the bushing. Check the clearance between the stem and bushing. Ream the bushing, if necessary, until the stem travels freely in the bore. Install the o-ring on the actuator stem. Install new piston packings if necessary.
3. Lightly coat the O.D. of the piston, packing and felt seal with OCP-VI. Be sure the packing lip of the upper packing is toward the top of the piston and the lip of the lower packing is toward the bottom of the piston. Secure the two flat edges on the actuator ferrule in a vise. Install the o-ring in the bonnet.
4. Slide the spring into position in the bonnet. The smaller retainer diameter should be toward the bonnet.
5. Place the piston on the actuator stem so that the spring cavity faces the bonnet.
6. Install the lockwasher and stem nut on top of the piston and tighten until the piston bottoms on the shoulder of the stem.
7. Lightly coat the I.D. of the cylinder, the I.D. of the Quad ring, and the secondary piston with OCP-VI. Install the o-ring in the upper part of secondary piston and slowly slide the secondary piston into the cylinder. Use shim stock or a thin flat tool to compress the quad ring on the piston to get it started in the cylinder. Make sure the piston cavity is facing out. Slide the piston into the cylinder until it seats against the stop in the cylinder.
8. Install the o-ring and insert the air guide stem into the piston bore and out through the top of the cylinder. Turn in a clockwise direction to the desired position.
9. Install the jamnut to the air guide stem.
10. Lubricate the cylinder threads with Tri-Clover C137 lubricant. This will prevent the stainless steel threads from galling.
11. With the bonnet still clamped in the vise, slowly slide the cylinder over the piston. Use shim stock or a thin flat tool to compress the upper packing on the primary piston and get it started into the cylinder.
12. Thread the cylinder into the bonnet until it bottoms. Use a strap wrench for the last few turns.
13. Refer to the instructions for adjusting the intermediate position in the *Introduction* paragraph in this section.

# MAINTENANCE

## PARTS LIST: TYPE 280 ACTUATOR

Key #	Description	Part Number	No. Req.
1	Jamnut	25-361-280-18-S	1
2	Mounting nut	25-361-280-17-S	1
3	Body cylinder	25-361-280-01-S	1
4	Air coupler adapter	25-361-210-06-S	2
*5	O-ring	17-157-U	1
6	Mounting bolt	25-361-280-21-S	1
*7	O-ring	01-1154-13-34-U	1
8	Secondary piston	25-361-280-02	1
*9	Quad ring	17-137-Q	1
*10	O-ring	60YM23-1-34-U	1
11	Air guide stem assembly	25-361-280-16-S	1
12	Nut	NU1700H-SS	1
13	Lockwasher	15-74	1
14	Piston	25-361-210-02	1
*15	Vee block packing	17-97	2
*16	Felt seal	17-101	1
17	Spring assembly	25-361-210-07-S	1
*18	O-ring	10CPLO-3-73-1A-U	1
19	Bonnet	25-361-210-03-S	1
20	Vented plug	MS-105-58A-CP	1
*21	Retaining ring	16-70	1
*22	Vee block packing	17-98	1
*23	Bushing	40-4	1
*24	O-ring	17-35-U	1
25	Stem	25-361-210-09-01-S	1
*26	Coupler	37-95A-SS	1

\* It is recommended that one spare part be stocked for each item marked with the exception of item 15, for which two spares should be stocked.

**Note:** It is recommended that a tube of C137 lubricant be stocked for servicing stainless steel

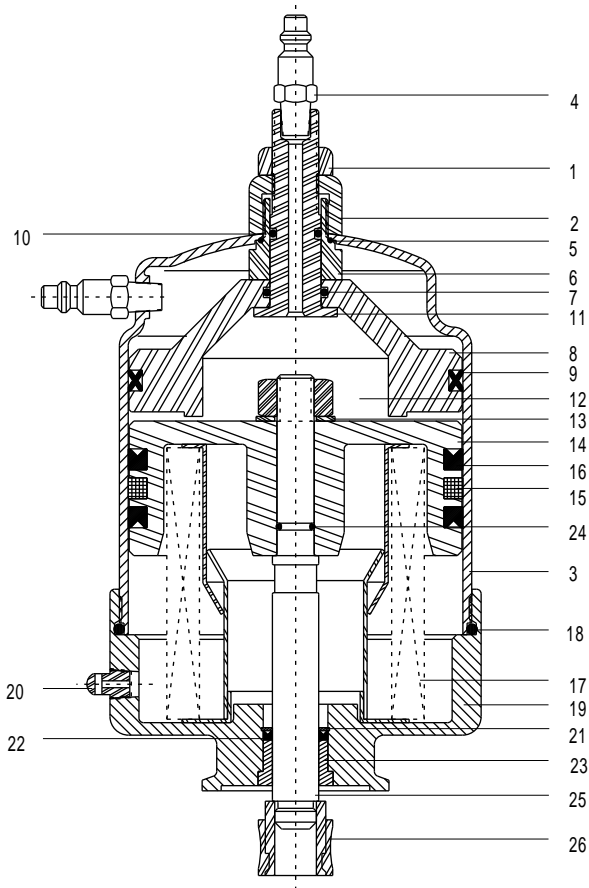

# MAINTENANCE

## TYPE 215 ACTUATOR

### INTRODUCTION

This actuator is spring return diaphragm unit, designed to utilize a diaphragm for reduced friction. It can be completely disassembled and rebuilt using Tri-Clover Replacement parts. Installation, maintenance, disassembly, and assembly instructions are covered below.

### INSTALLATION

Connect the air supply to the coupler. Air Supply Specifications: 30-50 psig (Normal).

### DIAPHRAGM REPLACEMENT

The diaphragm can rupture. When it fails, air will leak from the actuator vent plug. Follow the disassembly and assembly instructions.

### DISASSEMBLY

The actuator spring is not contained. Although preload force is low, caution must be used when spring force is released. Hand pressure must be applied to the cylinder top restricting its travel. Completely remove the actuator from the valve and follow the steps below.

1. Insert the bonnet flats into vise as illustrated at right.
2. Remove air coupler adapter and nut by turning counter clockwise.
3. Remove actuator cylinder from bonnet by applying a strap wrench to the cylinder and turn counterclockwise completely two times.

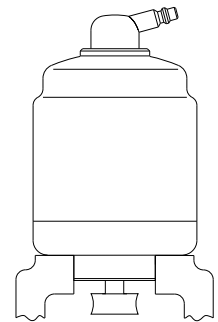

Apply constant hand pressure when unscrewing.

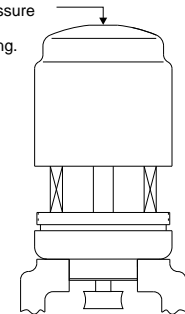

	<p style="text-align: center;"><b>⚠ WARNING</b></p> <p>To prevent injury, apply constant hand pressure and unscrew completely. Spring force will push the cylinder up when threads disengage.</p>
---	---

4. Pull cylinder assembly off the bonnet and remove spring.
5. Separate diaphragm assembly from cylinder by holding cylinder and pulling on actuator stem.
6. Place diaphragm assembly into a vise and secure Inner Diaphragm Guide as illustrated at right. Do not over tighten. Remove stem by locating a wrench around the flats and turn counterclockwise. Remove adapter and nut. The nut may be removed by inserting a punch into the hole in its face, and tapping nut counterclockwise.
7. Remove diaphragm assembly from vise and separate.

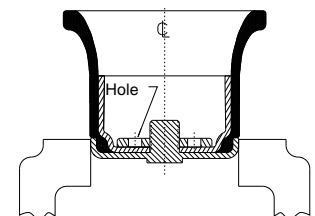

# MAINTENANCE

## REASSEMBLY

1. Clamp the Inner Diaphragm Guide in a vise with its threaded stud facing upward.
2. Set the diaphragm into the Inner Guide, set the Inner Diaphragm Clamp inside the diaphragm, screw on the nut until hand tight. Thread on the adapter and tighten to 15 ft.-lbs.
3. Lubricate the diaphragm inside and outside completely with L1 011B Sanitary Silicone Spray. Roll the diaphragm onto outer diaphragm clamp. Slide body insert onto outer diaphragm retainer.
4. Carefully slide diaphragm assembly into cylinder. Do not scratch, tear or abrade diaphragm.
5. Install sealing nut, gasket and air coupler adapter.
6. Insert the bonnet flats into vise as illustrated above. Place spring into bonnet.
7. Lubricate the cylinder threads with Tri-Clover C137 lubricant. This will help prevent the threads from galling. Place cylinder assembly onto spring.

	<p style="text-align: center;"><b>⚠ CAUTION</b></p> <p>To prevent injury, compress the spring by hand and thread the cylinder onto the bonnet for at least 3 complete turns. Apply a strap wrench to the cylinder and tighten until it "bottoms" onto the bonnet.</p>
--	---

8. Remove actuator from vise. Insert bushing into counter bores on bonnet.
9. Apply Removable Loctite\* to the fine threads of the actuator stem. Push actuator stem through bonnet and thread into adapter. Fasten completely with a wrench using stem flats.

\* Loctite is a registered trademark of Loctite Corporation.

# MAINTENANCE

## PARTS LIST: TYPE 215 ACTUATOR

Key #	Description	Part Number	No. Req.
1	Actuator body cylinder	25-263B-10-S	1
2	Air coupler adapter	37-5-S	1
3	Gasket	17-88	1
4	Sealing nut	13-78-S	1
5	Outer diaphragm clamp/ retainer	36-55	1
6	Body insert	37-88	1
* 7	Diaphragm	35-1	1
8	Top diaphragm clamp/ retainer	36-15	1
9	Inner diaphragm clamp/ retainer	36-3	1
10	Nut-retainer	13-15	1
11	Adapter	37-89-316	1
12	Compression spring	4-2-S	1
13	Bonnet	12-283A	1
14	Vented plug	MS-150-58A-CP	1
* 15	Bushing	40-4	1
16	Actuator stem	19-600-01	1
* 17	Coupler	37-95A-SS	1

\* It is recommended that one spare part be stocked for each item marked.

**Note:** It is also recommended that a tube of C137 lubricant be stocked for servicing stainless steel actuators.

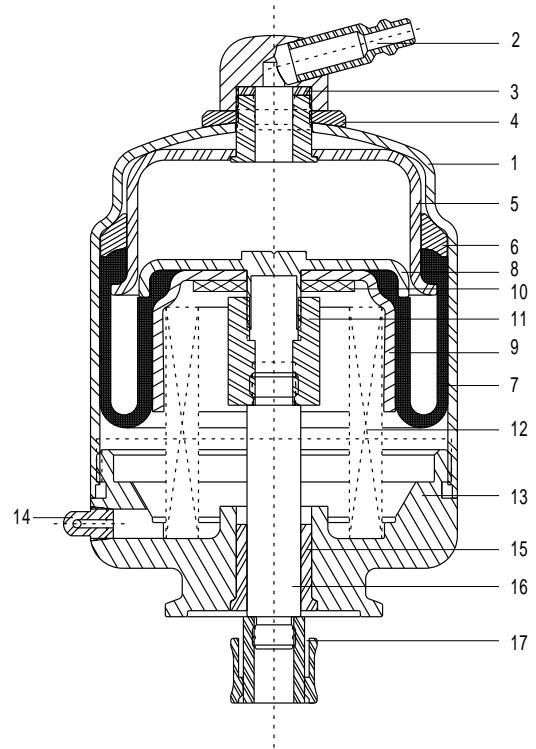

# PARTS LIST

## 361/361TR SHUT OFF VALVES

## 371-10, 30, & 27 THROTTLING VALVES

All orders for repair parts must contain the following data.

1. Complete model number (located on actuator nameplate), including size.
2. Valve serial number (located on nameplate).
3. Description and part number.

The following exploded view and accompanying parts list facilitate ordering repair parts from the factory. All parts illustrated are indexed to the parts list by key numbers.

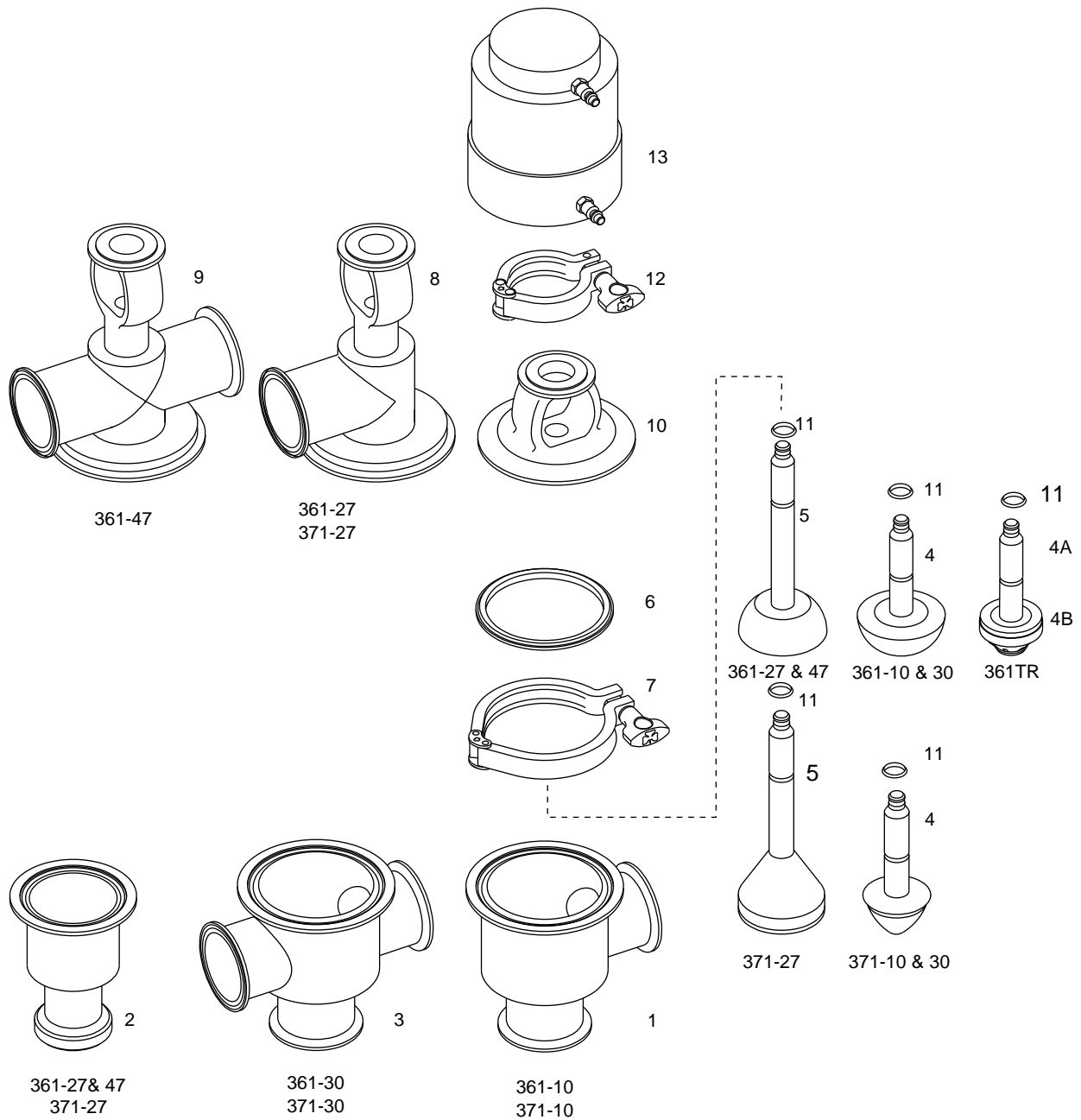

# PARTS LIST

## 361/361TR SHUT OFF VALVES 371-10, 30, 27 THROTTLING VALVE

Key #	Description	1"	1 1/2"	2"	2 1/2"	3"
* 1	Valve, lower body- Models 361-10 & 371-10	7-225T-1-316	7-184T-1 1/2-316	7-184T-2-316	7-184T-2 1/2-316	7-184T-3-316
* 2	Valve, lower body- Models 361-27, 47 & 371-27	-	7-200A-1 1/2-316	7-200A-2-316	7-200A-2 1/2-316	7-200A-3-316
* 3	Valve, lower body- Models 361-30 & 371-30	7-225C-1-316	7-184C-1 1/2-316	7-184C-2-316	7-184C-2 1/2-316	7-184C-3-316
• 4	Valve, plug assembly- Models 361-10 & 30 (Buna N Molded)	19-571-1-316	19-571-1 1/2-316	19-571-2-316	19-571-2 1/2-316	19-571-3-316
• 4A	Models 371-10 & 30 "TR" stem/seat plug assembly	19-1215-1-316	19-1215-1 1/2-316	19-1215-2-316	19-1215-2 1/2-316	19-1215-3-316
• 4B	Model 361TR 10 & 30 "TR" PTFE Snap-On seat only	19TR-571-1-316	19TR-571-1 1/2-316	19TR-571A-2-316	19TR-571-2 1/2-316	19TR-571-3-316
• 5	Valve, plug assembly- Models 361-27 & 47 (Buna N Molded)	20-514-1	20-514-1 1/2	20-514C-2	20-514C-2 1/2	20-514C-3
• 5	Valve, plug assembly 361-27	-	19-733-1 1/2-316	19-733-2-316	19-733-2 1/2-316	19-733-3-316
• 6	Body, gasket-361 Body, gasket-371	17-62-1 1/2-U 17-62-2-U	19-1059-1 1/2-316 17-62-2-U	19-1059-2-316 17-62-2 1/2-U	19-1059-2 1/2-316 17-62-3 1/2-U	19-1059-3-316 17-62-4-U
7	Body, clamp	17-62-2	17-62-2	17-62-2 1/2	17-62-3 1/2	17-62-4
* 8	Valve, upper body- Models 361-27 & 371-27	H13MHHM-1 1/2-S	13MHHM-3-S 7-192T-1 1/2-316	113MHHVM-3-S 7-192T-2-316	13MHHVM-4-S 7-192T-2 1/2-316	13MHHM-5-S 7-192T3-316
* 9	Valve, upper body- Model 361-47	-	192C-1 1/2-316	7-192C-2-316	7-192C-2 1/2-316	7-192C-3-316
10	Valve, bonnet-10 & 30	12-146-1-316	12-146-1 1/2-316	12-146-2-316	12-146-2 1/2-316	12-146-3-316
• 11	O-ring, valve plug stem-361 O-ring, valve plug stem-371	17-1-U25 17-1-U**	17-1-U25 17-1-U**	17-1-U25 17-1-U**	17-5-U25 17-5-U**	17-5-U25 17-5-U**
12	Actuator clamp	13MHHM-2-S	13MHHM-2-S	13MHHM-2-S	13MHHM-2-S	13MHHM-2-S
§ 13	Actuator-Type 210 Normally Open, Air to Close	25-361-210-S	25-361-210-S	25-361-210-S	25-361-210-S	25-361-210-S
13	Actuator-Type 215 Normally Open, Air to Close	25-263B-S	25-263B-S	25-263B-S	25-263B-S	25-263B-S
§ 13	Actuator-Type 220 & 225 Normally Closed, Air to Open	25-361-220-S	25-361-220-S	25-361-220-S	25-361-220-S	25-361-220-S

\* Note: Specify the type of port connections required.

• It is recommended that one each of these items be stocked as spare parts. (#11 sold in packages of 25 pcs.)

§ Valve models 361-27 and 361-47 are reverse acting, so the "normally open" actuator 210 is reversed and becomes "normally closed"; "normally closed 220 actuator is reversed and becomes "normally open."

\*\* U=Buna Mati.

# PARTS LIST

## 361/361TR DIVERT VALVES

## 371-21 THROTTLING DIVERT VALVE

All orders for repair parts must contain the following data.

1. Complete model number (located on actuator nameplate), including size.
2. Valve serial number (located on nameplate).
3. Description and part number.

The following exploded view and accompanying parts list facilitate ordering repair parts from the factory. All parts illustrated are indexed to the parts list by key numbers.

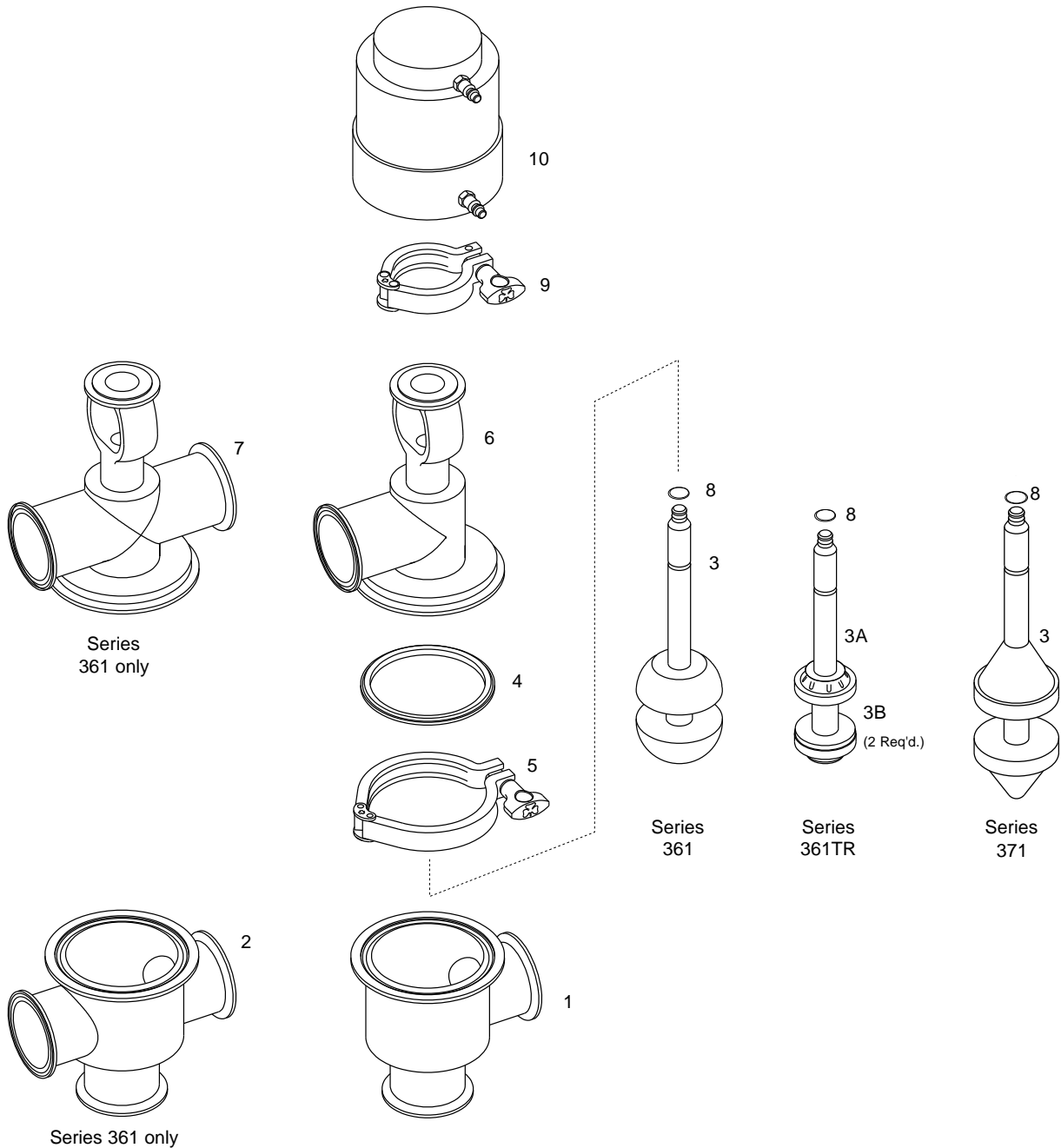



# PARTS LIST

## 361/361TR DIVERT VALVES 371-21 THROTTLING DIVERT VALVE

* 1	Valve, lower body, Models 361-21, 41 & 371-21	7-184T-1 <sup>1</sup> / <sub>2</sub> -316	7-184T-2 <sup>1</sup> / <sub>2</sub> -316	7-184T-3-316
* 2	Valve, lower body Models 361-23, 43	7-184C-1 <sup>1</sup> / <sub>2</sub> -316	7-184C-2 <sup>1</sup> / <sub>2</sub> -316	7-184C-3-316
• 3	Valve, plug assembly (Buna N Molded)-361	19-572-1 <sup>1</sup> / <sub>2</sub> -316	19-572-2 <sup>1</sup> / <sub>2</sub> -316	19-572-3-316
• 3A	Valve, plug assembly-371 "TR" stem/seat plug assembly	19-983-1 <sup>1</sup> / <sub>2</sub> -316 19TR-572A-1 <sup>1</sup> / <sub>2</sub> -316	19-983-2 <sup>1</sup> / <sub>2</sub> -316 19TR-572B-2 <sup>1</sup> / <sub>2</sub> -316	19-983-3-316 19TR-572B-3-316
• 3B	"TR" PTFE Snap-On seat only	20-514-1 <sup>1</sup> / <sub>2</sub>	20-514C-2 <sup>1</sup> / <sub>2</sub>	20-514C-3
• 4	Body, gasket-361 Body, gasket-371	17-62-2-U 17-62-2-316	17-62-2 <sup>1</sup> / <sub>2</sub> -U 17-62-2 <sup>1</sup> / <sub>2</sub> -316	17-62-4-U 17-62-4-316
5	Body, clamp	13MHHM-3-S	13MHHVM-3-S	13MHHM-5-S
* 6	Valve, upper body- Models 361-21, 23 & 371-21	7-192T-1 <sup>1</sup> / <sub>2</sub> -316	7-192T-2 <sup>1</sup> / <sub>2</sub> -316	7-192T-3-316
* 7	Valve, upper body- Models 361-41, 43	7-192C-1 <sup>1</sup> / <sub>2</sub> -316	7-192C-2 <sup>1</sup> / <sub>2</sub> -316	7-192C-3-316
• 8	O-ring-valve plug stem-361 O-ring-valve plug stem-371	17-1-U25 17-1-U**	17-5-U25 17-5-U**	17-5-U25 17-5-U**
9	Actuator clamp	13MHHM-2-S	13MHHM-2-S	13MHHM-2-S
10	Actuator-Type 210 Normally Open, Air to Close	25-361-210-S	25-361-210-S	25-361-210-S
10	Actuator-Type 215 Normally Open, Air to Close	25-263B-S	25-263B-S	25-263B-S
10	Actuator-Type 220 & 225 Normally Closed, Air to Open	25-361-220-S	25-361-220-S	25-361-220-S

- \* Note: Specify the type of port connections required.  
 • It is recommended that one each of these items be stocked as spare parts.  
 \*\* U=Buna Matl.

**Tri-Clover**

**manufactures**

**a complete line of**

**TRI-WELD® fittings**

**TRI-CLAMP® fittings**

**BEVEL SEAT fittings**

**POSITIVE PUMPS**

**CENTRIFUGAL PUMPS**

**AUTOMATIC Air Actuated VALVES**

**STAINLESS STEEL TUBING**

**AUTOMATED FLOW CONTROL SYSTEMS**

**Terms, Warranty Provisions, Notice of Claims and Limitation of Liability**

Prices and all terms and conditions of sale are established in current price sheets and are subject to change without notice. All orders are subject to acceptance by Tri-Clover Inc. at its Kenosha, Wisconsin or Distribution Center\* offices only. No assignment of the purchaser's rights may be made without consent of Tri-Clover Inc.

Each Tri-Clover item is warranted to be free from manufacturing defects for a period of one (1) year from the date of shipment, providing it has been used as recommended and in accordance with recognized piping practice, and providing it has not been worn out due to severe service, such as encountered under extremely corrosive or abrasive conditions.

**This warranty is expressly in lieu of any other warranties, express or implied, including but not limited to, any implied warranty of merchantability or fitness for a particular purpose.**

All claims must be in writing and must be mailed or delivered by purchaser within thirty (30) days after purchaser learns of the facts upon which such claim is based. Any claim not made in

writing and within the time period specified above shall be deemed waived.

**Purchaser's sole and exclusive remedy and Tri-Clover Inc.'s maximum liability for claims arising hereunder or for negligence for any and all losses and damages resulting from any cause shall be either the repair or replacement of defective items or, at Tri-Clover Inc.'s option, the refund of the purchase price for such items. In no event, including in the case of a claim for negligence, shall Tri-Clover be liable for incidental or consequential damages including loss of profits.**

No person, including any representative, employee or agent of Tri-Clover, is authorized to assume on behalf of Tri-Clover Inc., any liability or responsibility in addition to or different from that described in this provision. Any and all representations, promises, warranties or statements that are in addition to or different from the terms of this provision are of no force or effect.

*\*Distribution Centers in Union City, California and Memphis, Tennessee*



**Tri-Clover Inc.**

**Food & Dairy Division**  
9201 Wilmot Road  
Kenosha, Wisconsin 53141-1413  
PHONE: 1-800-242-4000  
FAX: 414-694-7104

**Distribution Centers**  
*Memphis, TN*  
PHONE: 1-800-238-0142  
*Union City, CA*  
PHONE: 1-800-852-3178

**Bio-Pharm Division**  
PHONE: 1-800-511-5444  
FAX: 414-694-2454

**Tri-Clover Canada**  
101 Milner Avenue  
Scarborough, Ontario M1S4S6  
PHONE: 416-297-3400  
FAX: 416-299-5095

**Export Division**  
PHONE: 1-414-697-3170  
FAX: 1-414-694-8188

**Tri-Clover Mexico**  
Recursos Petroleros No. 7  
Fracc. Ind. La Loma  
54060 Tlalnepanitla, Edo. de Mexico  
PHONE: 52-5-397-0601  
FAX: 52-5-362-3246



**CSI** 417.831.1411  
csidesigns.com

