



Instruction Manual

Rotary Jet Mixer IM 20

- Covering**
- **Standard Machines**
 - **Machines delivered with ATEX Certification in accordance with Directive 94/9/EC**

IM-TE91I350-EN5
ESE02185EN

Date of issue: February 4, 2015
First published: December 2009

Original manual

Contents

Contents	1
Introduction	3
Intended Use	3
Patents and trademarks.....	3
ATEX Marking	4
General Description	5
Functionality.....	5
Standard configurations for IM 20 Rotary Jet Mixer.....	9
Available add-ons	9
Technical data	10
Rotary Jet Mixer IM 20 with 4 nozzles	10
Principal dimensions in mm	10
Rotary Jet Mixer IM 20 with 2 nozzles	11
Principal dimensions in mm	11
Flow rate.....	12
Throw length.....	13
Time for complete pattern (8 cycles).....	14
Installation and Normal Operation	15
General Safety and Installation Instructions.....	15
Method for tightening the nozzles	16
Normal Operation	17
Special Conditions for Safe Use in accordance with the ATEX Certification, Directive 94/9/EC.....	19
Service and Repair of ATEX Approved Machines.....	20
Maintenance and Repair	22
Preventive Maintenance	22
Top Assembly.....	24
Bottom Assembly.....	26
Hub Subassembly.....	28
Hub Assembly.....	29
Stem Subassembly.....	30
Gear Subassembly	32
Replacement of Collar Bushes	34
Replacement of Ball Races.....	36
Replacement of Main Collars.....	38
Tools	40
Standard Tool kit for Alfa Laval Rotary Jet Mixer Iso-Mix 20, article no. TE81B075	40
Sketch of Tools for replacement of Collar bush	40
Sketch of Tools for replacement of Main collars	41
Trouble Shooting Guide.....	42
IM 20 Rotary Jet Mixer with 4 nozzles.....	44
Reference list of parts.....	44
Cross Sectional Drawing.....	45

Contents

IM 20 Rotary Jet Mixer with 2 nozzles	46
Reference List of Parts	46
Cross sectional drawing.....	47
Service intervals	48
Standard Spare Part Service Kits and Tool Kits.....	48
Standard Spare Part Service Kit for IM 20 Rotary Jet Mixer, Article No. TE32B299.....	48
Standard Tool Kit for IM 20 Rotary Jet Mixer, Article No. TE81B075.....	48
Special Tools for IM 20 Rotary Jet Mixer	48
General information	49
How to Order Spare Parts.....	49
Service and Repair	49
How to contact Alfa Laval Tank Equipment	49
Declaration of Conformity	50

© Alfa Laval Corporate AB

This document and its contents is owned by Alfa Laval Corporate AB and protected by laws governing intellectual property and thereto related rights. It is the responsibility of the user of this document to comply with all applicable intellectual property laws. Without limiting any rights related to this document, no part of this document may be copied, reproduced or transmitted in any form or by any means (electronic, mechanical, photocopying, recording, or otherwise), or for any purpose, without the expressed permission of Alfa Laval Corporate AB. Alfa Laval Corporate AB will enforce its rights related to this document to the fullest extent of the law, including the seeking of criminal prosecution.

Introduction

This manual has been prepared as a guide for the persons who will be operating and maintaining your Rotary Jet Mixer Iso-Mix 20. The key to long life for your mixer will always be a system of carefully planned maintenance procedures; you will appreciate that a mixer which has a rough job to do will need more frequent attention than one working in ideal conditions.

Note: Get the best and most economical performance from your Rotary Jet Mixer Iso-Mix 20. Insufficient preventive maintenance means poor performance, unscheduled stops, shorter lifetime and extra costs. Good preventive maintenance on the contrary means good performance, no unscheduled stops and superior total economy.

You will find the information contained in this manual simple to follow, but should you require further assistance, our Technical Department will be pleased to help you. Please quote the type and serial number with all your enquiries; this will help us to help you. The type and serial number are placed on the gear house of the mixer.

Note: The illustrations and specifications contained in this manual were effective at the date of printing. However, as continuous improvements are our policy, we reserve the right to alter or modify any unit specification on any product without prior notice or any obligation.

Intended Use

It is to be verified by the end-user:

- that the machine is in conformity with respect to tank, vessel or container size in which it will be used.
- that the construction materials (both metallic and non-metallic) are compatibility with product, flushing media, cleaning media, temperatures and pressure under the intended use.

Patents and trademarks

This Instruction Manual is published by Alfa Laval Kolding A/S without any warranty. Improvements and changes to this Instruction Manual may at any time be made by Alfa Laval Kolding A/S without prior notice. Such changes will, however, be incorporated in new editions of this Instruction Manual.

© Alfa Laval Kolding A/S. All rights reserved.

Rotary Jet Mixer Iso-Mix 20 product has patents in the EPO member states and in other countries. The Alfa Laval logotype is a trademark or a registered trademark of Alfa Laval Corporate AB. Other products or company names mentioned herein may be the trademarks of their respective owners. Any rights not expressly granted herein are reserved.

If ordered with ATEX certificate:

ATEX Marking

The Rotary Jet Mixer IM 20 is certified as category I component. The certification is carried out by the certified body Baseefa, who has issued the certificate no. 10ATEX0188X. The marking on the ATEX certified Rotary Jet Mixer IM 20 is as follows:

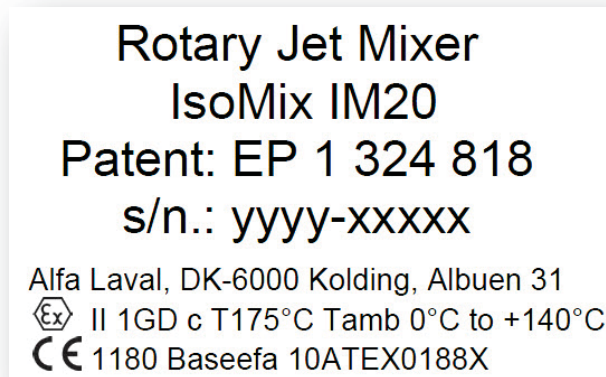

Serial number explanation

Machines supplied with or without normal documentation:

yyyy-xxxxx: serial number

yyyy: year

xxxxx: 5 digit sequential number

Changes to the machine are not allowed without approval by the person responsible for the ATEX certification at Alfa Laval Tank Equipment. If changes are made – or spare parts other than Alfa Laval original spare parts are used - the EC Type Examination certification (the ATEX Directive) is no longer valid.

Important ATEX information:



Also see page 19 regarding special conditions for repair of ATEX certified machines.

General Description

The Rotary Jet Mixer Iso-Mix 20 is a media driven and media lubricated tank/reactor mixer.

Functionality

The Rotary Jet Mixer Iso-Mix 20 is placed inside the tank/reactor under the liquid surface of the liquid volume to be mixed.

The mixer is combined with an external recirculation loop. The fluid of the tank/reactor is recirculated through this loop and reintroduced in the tank/reactor through the Rotary Jet Mixer Iso-Mix 20. The more fluid being recirculated, the more effective mixing is obtained.

The mixer should be placed in the centre of the fluid to be mixed. Minimum ½ meter under the liquid surface.

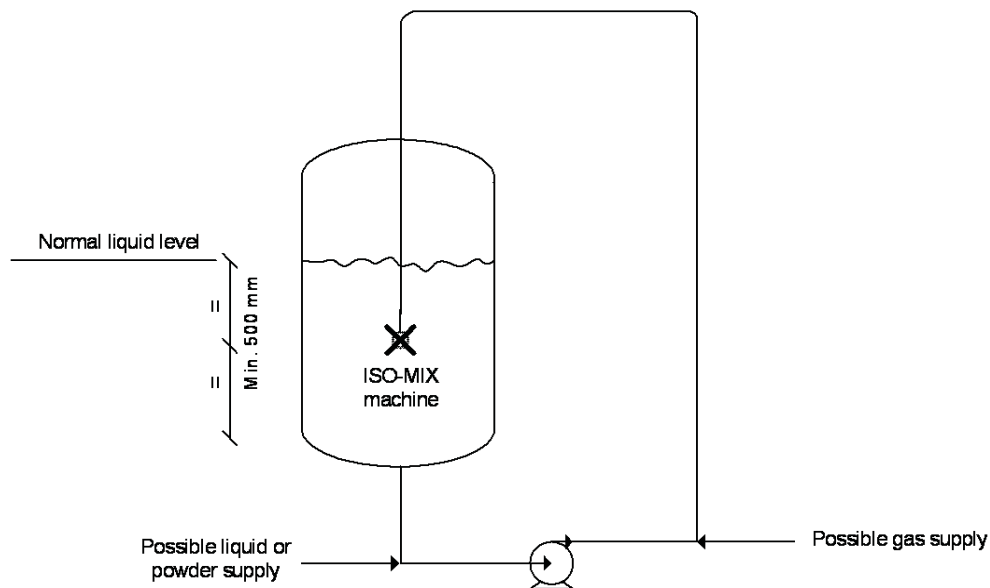

The flow of fluid to be mixed passes from the tank into the mixer through a turbine, which is set into rotation. The turbine rotation is through a gearbox transformed into a combined horizontal rotation of the mixer body and a vertical rotation of the nozzles.

General Description (continued)

Functioning (continued)

Machines with 2 nozzles

The combined motion of the mixer body and the nozzles ensures a fully indexed tank mixing. After $11\frac{1}{4}$ revolutions of the Hub with nozzles ($10\frac{3}{4}$ revolutions of the mixer body), one coarse movement pattern has been established which when projected on the tank surface looks as Figure 1. During the following cycles, this pattern is repeated 3 times, each of which is displaced $\frac{1}{4}$ of the mesh in the pattern. After a total of 45 revolutions of the Hub with nozzles (43 revolutions of the machine body), a complete "mixing pattern" has been laid out, and the first pattern is repeated. This feature eliminates "dead volumes" in the tank, and makes the Rotary Jet Mixer Iso-Mix 20 very efficient automatic tank cleaning machine, when the tank is empty.

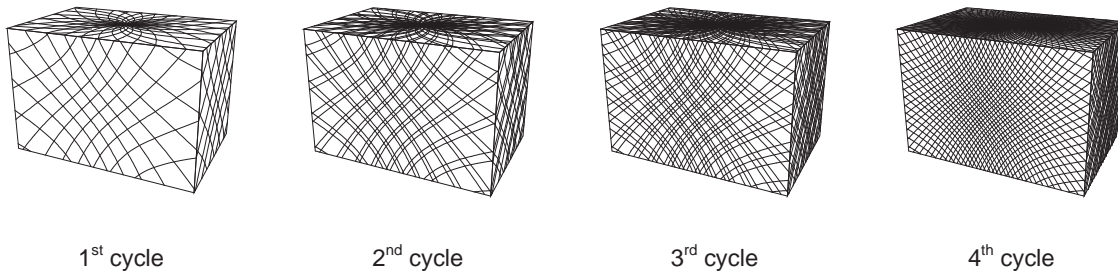

Machines with 4 nozzles

The combined motion of the mixer body and the nozzles ensures a fully indexed tank mixing. After $5\frac{5}{8}$ revolutions of Hub with nozzles ($5\frac{5}{8}$ revolutions of the mixer body), one coarse movement pattern has been established which when projected on the tank surface looks as Figure 1. During the following cycles, this pattern is repeated 7 times, each of which is displaced $\frac{1}{8}$ of the mesh in the pattern. After a total of 45 revolutions of the Hub with nozzles (43 revolutions of the mixer body), a complete "mixing pattern" has been established, and the first pattern is repeated. This feature eliminates "dead volumes" in the tank, and makes the Rotary Jet Mixer Iso-Mix 20 very efficient automatic tank cleaning machine, when the tank is empty.

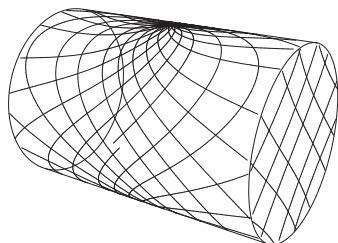

Figure 1. First cycle

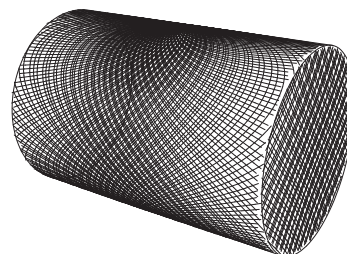

Figure 2. Full pattern

General Description (continued)

Functioning (continued)

General for both 2 and 4 nozzle machines

The speed of rotation of the turbine depends on the flow rate through the mixer. The higher the flow rate is, the higher the speed of rotation will be. In order to control the RPM of the mixer for a wide range of flow rates, the efficiency of the turbine can be changed by using 100% or 0% turbine/inlet guide.

Apart from the jet flow through the nozzles, fluid is leaking through the top of the mixer, at the hub and through the bottom cover. The leakages between the moving parts at the top and at the hub are cleaning the gabs and thus preventing build-up of material that might cause extra friction. The flow through the bottom cover is required to ensure proper lubrication of the gearbox.

The number of rotations required for a satisfactory mixing of a given tank volume depends on the energy input (kW/m^3 tank volume), the viscosity of the liquid, required mixing time, and number of mixers per tank.

It is possible to add fluid, gas or solids in the recirculation loop. These ingredients will very effectively be mixed into the entire tank/reactor volume.

When the tank/reactor is empty the Rotary Jet Mixer Iso-Mix 20 can be used as a tank cleaning machine.

- Blank page -

General Description (continued)

Standard configurations for IM 20 Rotary Jet Mixer

Connection	Turbine/Inlet Guide	Nozzles [mm], ¼" thread conn.			
		Nozzle size	Article No.	Article No. – E-gear	
<u>Top cone:</u> 2" BSP, Female	100%	4 x ø8 4 x ø9	TE32B081 TE32B091	TE32E081 TE32E091	
	0 %	4 x ø9	TE32B090	TE32E090	
		4 x ø10	TE32B100	TE32E100	
		4 x ø11	TE32B110	TE32E110	
		2 x ø12	TE32B112	TE32E112	
		2 x ø13	TE32B113	TE32E113	
		2 x ø14	TE32B114	TE32E114	
		2 x ø15	TE32B115	TE32E115	
		<u>Top cone:</u> 2" NPT, Female	100%	4 x ø8 4 x ø9	TE32B181 TE32B191
	0 %		4 x ø9	TE32B190	TE32E190
4 x ø10			TE32B200	TE32E200	
4 x ø11			TE32B210	TE32E210	
2 x ø12			TE32B212	TE32E212	
2 x ø13			TE32B213	TE32E213	
2 x ø14			TE32B214	TE32E214	
2 x ø15			TE32B215	TE32E215	

The mixer is equipped with a clutch in the hub, which gives the possibility of rotating the nozzles by hand, when the mixer is not under pressure and first has to be lifted out or in through a tank opening.

Available add-ons

ATEX, category 1 for installation in zone 0/20
 - TE32XXXX-70 ATEX

Explanation to Add-ons

ATEX, category 1 for installation in zone 0/20 in accordance with Directive 94/9/EC

Technical data

Rotary Jet Mixer IM 20 with 4 nozzles

Weight of mixer	:	13 kgs (28.6 lb)
Working pressure	:	2-12 bar (30-175 psi)
Recommended inlet pressure	:	3-8 bar (45-120 psi)
Working temperature max.	:	120° C (248° F)
Max. temperature	:	140°C (284°F)
Ambient temperature	:	0 – 140°C (120°C – 140°C when not operated)
Materials	:	Stainless steel AISI 316/316L, PEEK 450G, SAF 2205, Teflon, TFM, Tefzel, ceramics

Principal dimensions in mm

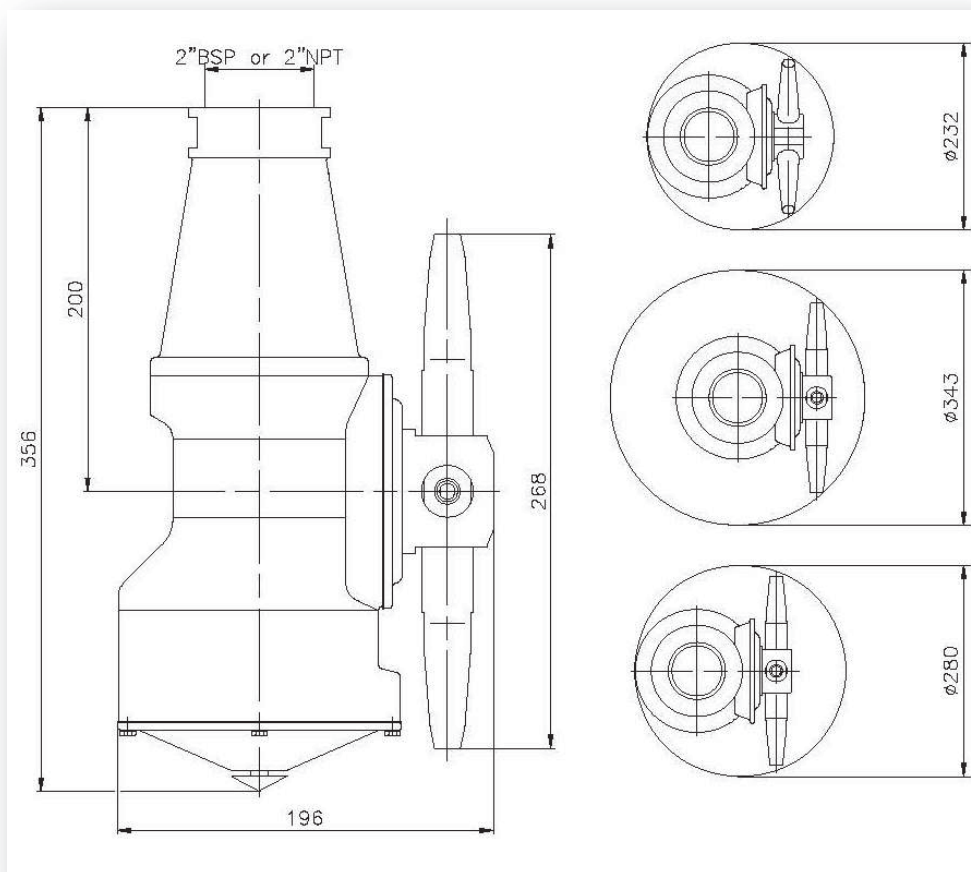

Technical data (continued)

Rotary Jet Mixer IM 20 with 2 nozzles

Weight of mixer	:	13 kgs (28.6 lb)
Working pressure	:	2-12 bar (30-175 psi)
Recommended inlet pressure	:	3-8 bar (45-120 psi)
Working temperature max.	:	120° C (248° F)
Max. temperature	:	140°C (284°F)
Ambient temperature	:	0 – 140°C (120°C – 140°C when not operated)
Materials	:	Stainless steel AISI 316/316L, PEEK 450G, SAF 2205, Teflon, TFM, Tefzel, ceramics

Principal dimensions in mm

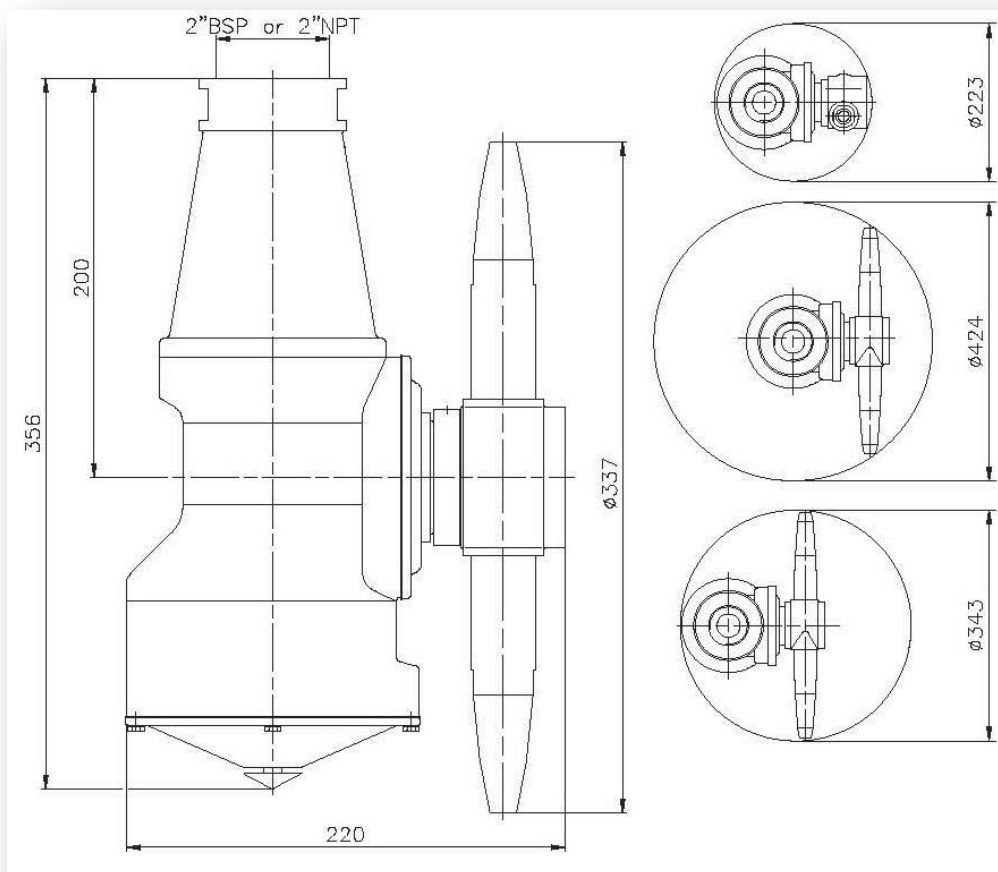

Technical data (continued)

Flow rate

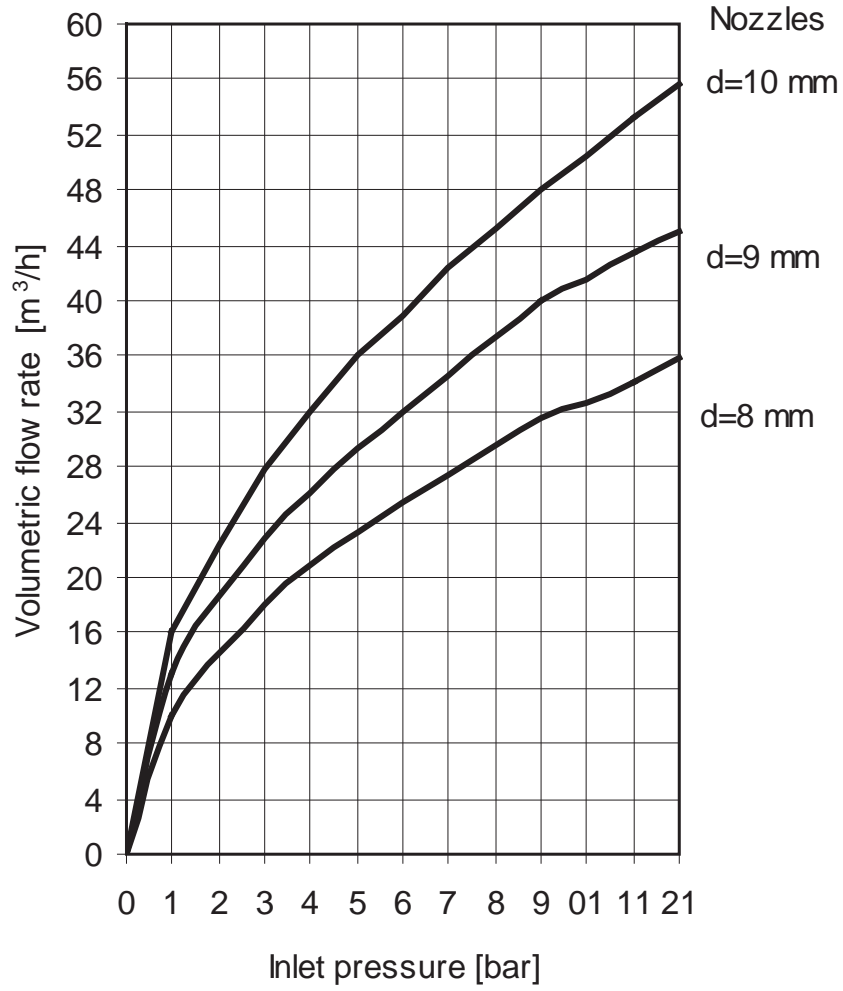

Technical data (continued)

Throw length

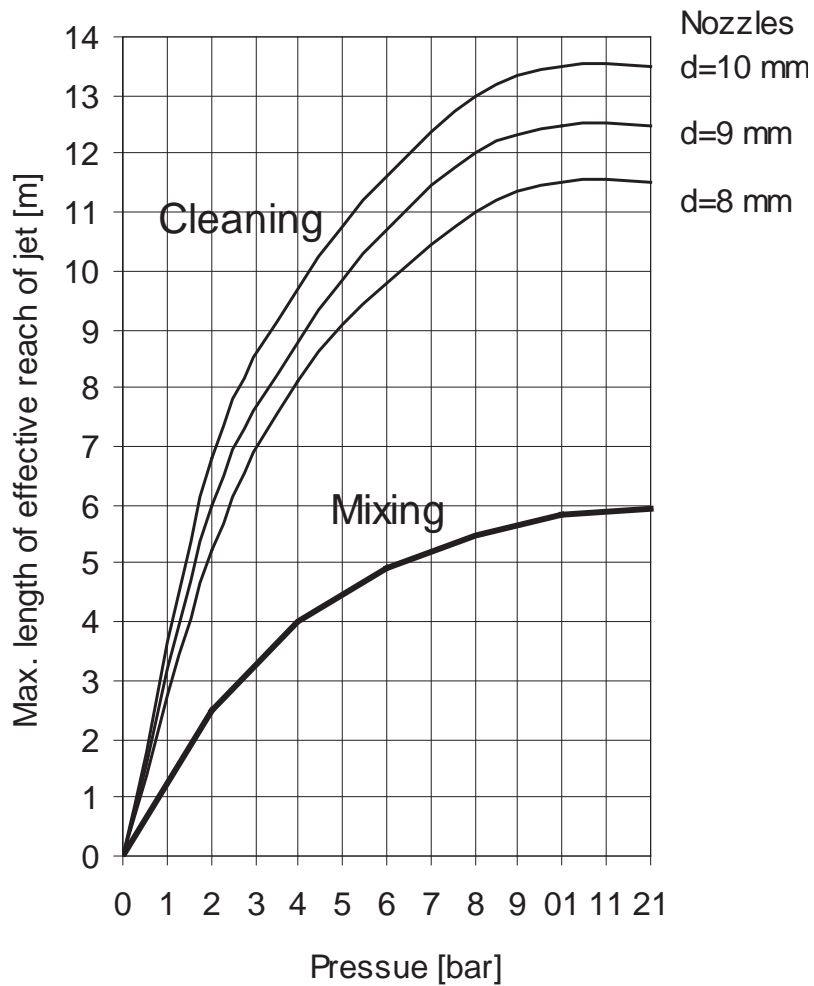

Note: The distance (reach) of the jet from the rotary nozzles at which the jets still have a reasonable mixing effect depends i.a. of pressure, the diameter of the nozzles, the viscosity of the fluid, the desired mixing time and various other parameters. The effective reach of the jets as indicated above is in a fluid with a viscosity of 1 cP.

The pressure is measured at the mixer. This means that due consideration shall be taken to pressure drops in the recirculation line from the pump to the mixer as well as to static pressure differences, when the jet mixing system is being dimensioned.

Technical data (continued)

Time for complete pattern (8 cycles)

Min. RPM of machine body

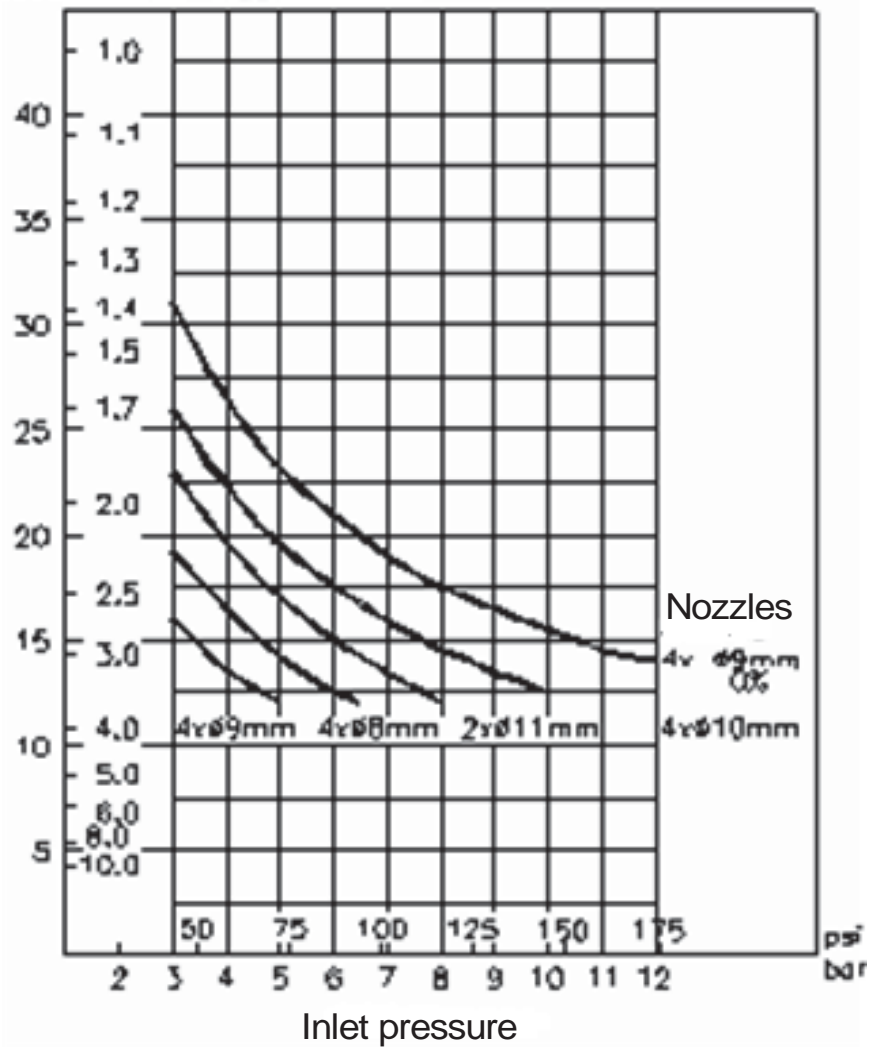

Installation and Normal Operation

General Safety and Installation Instructions

The Rotary Jet Mixer Iso-Mix 20 should be installed in vertical position (upright or upside down). It is recommended to install a filter in the supply line in order to avoid large particles to clog inside the mixer. Before connecting the mixer to the system, all supply lines and valves should be flushed to remove foreign matter.

For devices with tapered thread connections to the down pipe, it is recommended that you secure the connection in a manner appropriate for the application. Subject to the intended use environment and any in-house user requirements or policies, a liquid thread locking adhesive such as Loctite No. 243 or equivalent could be used. Other methods could be acceptable and subject to customer preference.

Note: The machine shall be installed in accordance with national regulations for safety and other relevant regulations and standards.

Precautions shall be made to prevent starting of the cleaning operation, while personnel are inside the tank or otherwise can be hit by jets from the nozzles.

In EU-countries the complete system must fulfil the EU-Machine Directive and depending of application, the EU-Pressure Equipment Directive, the EU-ATEX Directive and other relevant Directives and shall be CE-marked before it is set into operation.

**ATEX
Warning:**



If the machine is used in potential explosive atmospheres, tapes or joint sealing compounds which are electrical insulators must not be used on threads or joints, unless an electrical connection is otherwise established to ensure an effective earthing. In addition, connecting pipe work, must be electrically conductive and earthed to the tank structure. The resistance between the nozzles and the tank structure should not exceed 20,000 Ohm. This is essential to avoid the build-up of static electricity on the machine.

For further information see DS/CLC/TR 50404:2003 Safety of Machinery, guidance and recommendations for the avoidance of hazards due to static electricity.

Electrical equipment such as magnetic valves and electric actuators must not be installed in Ex-zones without type approval and marking, corresponding to the EX-class in question.

The Rotary Jet Mixer Iso-Mix 20 as delivered has been tested at the factory before shipping. For transportation reasons, the nozzles have been screwed off after the test. In order to secure the nozzles against falling off during normal cause of service due to vibrations and other external strains it is important that the nozzles are tightened properly after mounting. If not, the nozzles may be blown off during mixing and cause severe damage on tank, valves and pump. This is especially important if mixers are installed in tanks and vessels within the transportation sector in trucks, railcars and onboard ships.

Normally, it is sufficient to tighten the nozzles with the specified torque. However, depending on the application and local policies extra securing may be preferred.

Installation and Normal Operation (continued)

Method for tightening the nozzles

1. Clamp machine firmly in a vice: Place machine on top of vice with Hub w. nozzles down wards as illustrated on the figure. Clamp on the Hub. To protect machine use rubber jaws on the vice.

With 2 nozzles:

2. Set torque wrench at the specified tightening torque.
3. Tighten nozzle with the torque



Recommended tightening torque: 50 Nm

With 4 nozzles:

2. Set torque wrench at the specified tightening torque.
3. Hold one nozzle with flat spanner to counteract while tightening the opposite nozzle with the torque wrench.

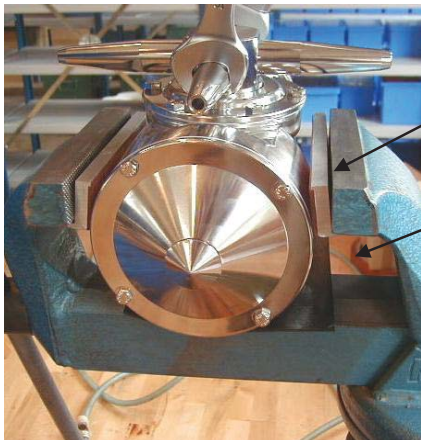

Rubber jaw mounted upside down

Protect with rubber pad



Recommended tightening torque: 50 Nm

Installation and Normal Operation (continued)

Method for tightening the nozzles

1. Check that the machine is in operating condition by inserting 3/16" hex Screwdriver (tool No. TE134A) in screw in top of Turbine shaft and easily turn Turbine shaft clockwise. If any resistance is recognised, the machine should be disassembled to localise the cause.

Normal Operation

Media to be mixed

The Rotary Jet Mixer Iso-Mix 20 should be used only in fluids compatible with stainless steel AISI 316/316L, PEEK 450G, SAF 2205, Teflon, TFM, Tefzel, ceramics (Al_2O_3). Please note that PEEK is not resistant to concentrated sulfuric acid. Furthermore, the fluids to be mixed should not contain abrasive materials and fibrous material and the viscosity should not be above 450 cP. Aggressive chemicals, excessive concentrations of chemicals at elevated temperatures, as well as certain hydrochlorides should be avoided. If you are in doubt contact Alfa Laval Tank Equipment.

Pressure shock

Avoid hydraulic shocks. Increase pressure gradually. Do not exceed 12 bar inlet pressure. Recommended inlet pressure appears from Technical Data (page 10-11). High pressure in combination with high flow rate will increase consumption of some of wear parts. It is recommended to install a hydrofor in the system, if a positive pump is used for recirculation.

ATEX Steam cleaning pressure.

Warning:



If steam cleaning is done through the machine, the steam pressure must not cause the machine to rotate.

ATEX Draining:

Warning:



If the machine is drained using compressed air, then the compressed air pressure must not cause the machine to rotate.

After use cleaning

After use flush the mixer with fresh water. Fluids should never be allowed to dry or set-up in the Rotary Jet Mixer Iso-Mix 20 due to possible "salting out" or "scaling" of the ingredient.

Installation and Normal Operation (continued)

Normal Operation (continued)

Temperature

In accordance with the ATEX specifications regarding special conditions for safe use, see page 19.

ATEX	<u>Steam cleaning</u>
Warning:	Tanks with capacities greater than 100 m ³ that could contain a flammable atmosphere should not be steam cleaned, as steam issuing from a nozzle could contain charged droplets.
	Tanks smaller than this may be steam cleaned providing that: the steam nozzles and other metal parts of the system are reliably earthed and grounded to the tank structure.

ATEX	<u>Atmosphere/surface temperature:</u>
Warning:	In potentially explosive atmospheres, the temperature must not exceed the maximum surface temperature according to the temperature class for the combustible gas or liquid.
	

Installation and Normal Operation (continued)

Special Conditions for Safe Use in accordance with the ATEX Certification, Directive 94/9/EC

ATEX Warning: The unit may be operated, in a hazardous area, only when filled with the process fluid.



ATEX Warning: The maximum permitted process fluid temperature and ambient temperature, when the machine is operating is 120°C.



When the machine is **not** operating, the maximum permitted ambient temperature is 140°C.

ATEX Warning: Working pressure:
The maximum permitted process fluid pressure is 12 bar.



ATEX Warning: The unit must not be operated in a vessel having an enclosed volume of greater than 100m³.
Tanks larger than 100 m³



To use Rotary Jet Mixers in tanks larger than 100m³ is possible under certain conditions.
It is necessary to know the current factors such as tank size, cleaning solvent and product.
Additives can be used in the cleaning solvent, or, for example, the tank can be filled with nitrogen. The basic rules are described in the guide "CLC / TR 50404:2003".
Following a guidance document such as "CLC / TR 50404:2003" to establish safe use of machinery and process is the users own responsibility and is not covered by the ATEX certification for this product.

ATEX Warning: The user must address the electrostatic hazards generated from the process of the equipment in accordance with guidance document CLC/TR 50404:2003.



In addition to the above mentioned precautions relating to the ATEX guidelines Directive 94/9/EC of March 23 1994, the Safety Precautions on page 15 must be observed.

Service and Repair of ATEX Approved Machines

In order to ensure compliance with the ATEX regulations for service and repair in accordance with EN 60079-19, all service and repair of ATEX approved machines should be performed by Alfa Laval Tank Equipment, Kolding, Denmark.

Warning: ATEX requirements regarding repair of ATEX approved machines according to EN 60079-19.



A tag with the following labelling information must be attached to the machine:

- Repair symbol
- Alfa Laval logo and address
- Repair number
- Date of repair
- Machine serial number

The tag must be laminated and attached to the machine-downpipe outside the tank using a cable tie.

If a customer wishes to carry out service or repair himself, it is the responsibility of the repair shop to ensure that the ATEX requirements are met in any way possible. After performing service or repair, the repair shop thus carries the full responsibility for the ATEX approval of the machine.

- Blank page -

Maintenance and Repair

Preventive Maintenance

In order to keep servicing you as an efficient tool in your tank mixing operations, it is essential to maintain its high performance by following a simple preventive maintenance programme, which will always keep your Rotary Jet Mixer Iso-Mix 20 in good condition.

Good maintenance is careful and regular attention!

The following recommended preventive maintenance is based on Rotary Jet Mixer Iso-Mix 20s working in average conditions. However, you will appreciate that an Rotary Jet Mixer Iso-Mix 20, which has a rough and dirty job to do, will need more frequent attention than one working in ideal conditions. We trust that you will adjust your maintenance programme to suit.

Always use only proper tools. Use Rotary Jet Mixer Iso-Mix 20 standard tool kit. Never force, hammer or pry components together or apart. Always perform all assembly/disassembly steps in the order described in this manual.

Never assemble components without previous mixing. This is especially important at all mating surfaces. Work in a clear well lighted work area.

Every 4000 working hours (depending on working conditions)

1. Disassemble mixer as described on the following pages.
2. Clean material build-up and deposits from internal parts with chemical cleaner and/or if desired fine abrasive cloth.
3. Check slide bearings (pos. 28) for wear. If hole is worn oval to max diameter more than 12.4 mm, Slide bearing should be replaced. If end face of slide bearing is worn more than x mm into slide bearing, it should be replaced.

Under turbine shaft: x = 1.5 mm

At horizontal shaft: x = 0.5 mm

4. Check collar bushes (pos. 12) in gear frame. If holes are worn oval to max diameter more than 15.4 mm, collar bush should be replaced. How to replace collar bushes, see page 34.

Note: Timely replacement of slide bearings and collar bushes will prevent costly damage to the gearbox.

Maintenance and Repair (continued)

Preventive Maintenance (continued)

5. Check worm wheels (pos. 11 and pos. 33). If extremely worn, they should be replaced.
6. Check main bush (pos. 5). If worn oval to max diameter more than 15.4 mm, it should be replaced.
7. Assemble mixers as described in the following pages.
8. Check that the mixer is in operating condition by inserting 3/16" Hex screwdriver (tool no. 134A) in screw in top of turbine shaft and easily turn turbine shaft clockwise. If any resistance is recognized, the mixer should be disassembled to localize the cause.

Apart from the parts specifically mentioned above, all the remaining wear parts should regularly be inspected for wear. Which parts that are wear parts appear from Reference List of Parts, page 44.

Maintenance and Repair (continued)

Top Assembly

Disassembly

1. Remove 1/4" screws (pos. 17). Loosen and unscrew with a socket wrench (tool no. 962A).
2. Lift off top cone (pos. 1).
3. Remove guide/guide ring (pos. 2). The guide has a groove in the outer diameter. The guide is easily lifted out of the stem by means of two ordinary screwdrivers inserted into the groove.
4. Remove 3/16" screw (pos. 15), spring washer (pos. 16) and washer (pos. 34). To secure impeller against rotation, insert carefully screwdriver (tool no. 135A), through impeller (pos. 4) into a hole in the stem.
5. Pull off impeller (pos. 4).

Reassembly

1. Reinstall impeller (pos. 4). Make sure that impeller is correctly rotated to be pushed onto turbine shaft. Do not try to hammer impeller in position, as this will damage slide bearing under turbine shaft.
2. Mount washer (pos. 34), spring washer (pos. 16) and 3/16" screw (pos. 15) and tighten. To secure impeller against rotation insert carefully screwdriver (tool No. 135A) through impeller (pos. 4) into a hole in the stem.
3. Reinstall guide/guide ring (pos. 2)
4. Mount top cone (pos. 1). Make sure that it is in correct position over guide/guide ring (pos. 2). Rotate top cone to align holes in top cone and stem.
5. Mount 1/4" screws (pos. 17) with a socket wrench (tool no. 962A).

Maintenance and Repair (continued)

Top Assembly

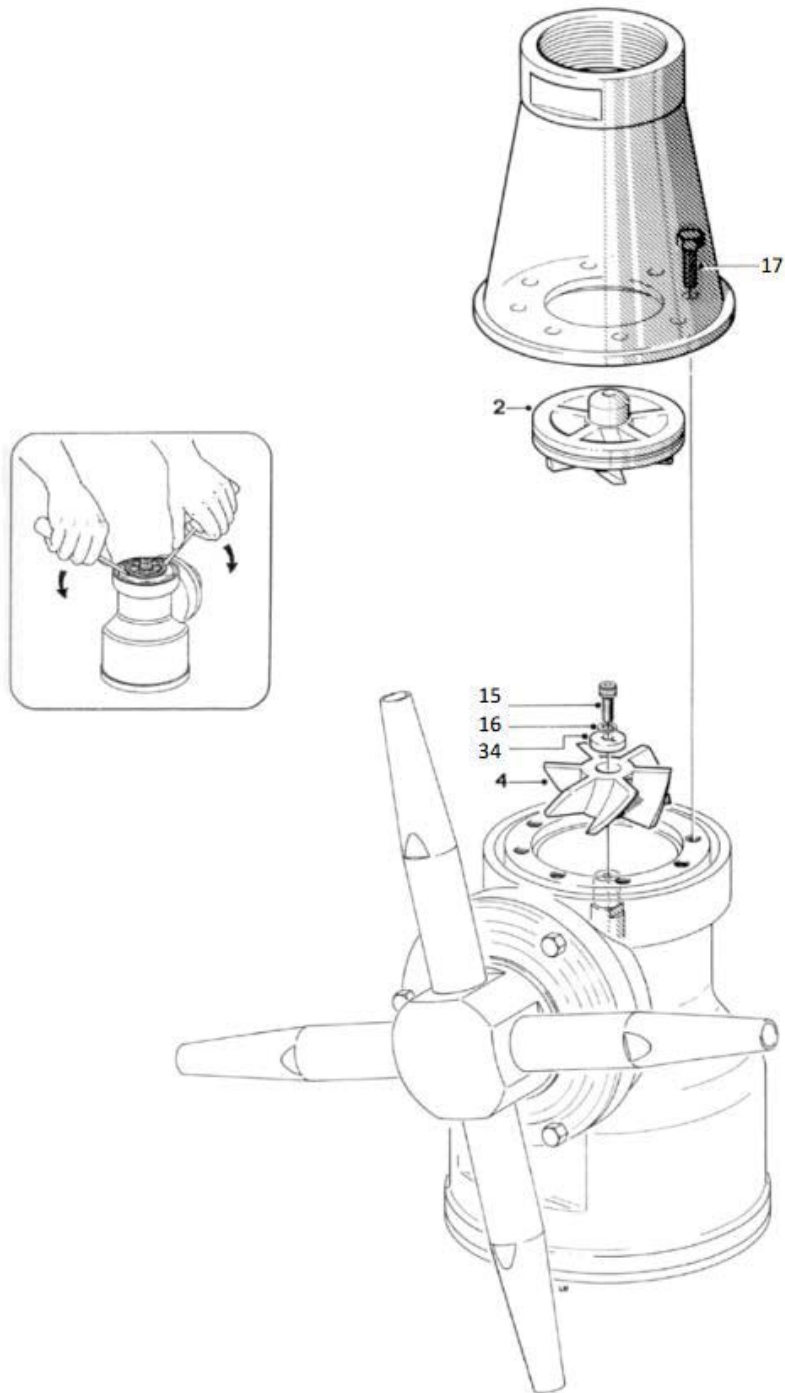

Maintenance and Repair (continued)

Bottom Assembly

Disassembly

1. Turn mixer upside down.
2. Remove 3/16" screws (pos. 31) from bottom cover (pos. 30).
3. Remove bottom cover (pos. 30) and gasket (pos. 32).
4. Remove 3/16" screw (pos. 15) and spring washers (pos. 16) along the circumference of gear frame (pos. 29). Draw out gear subassembly (holes in gear frame are excellent for holding gear subassembly).

Reassembly

1. Reinsert gear subassembly in bottom of mixer body. Mount spring washers (pos. 16) and 3/16" screws (pos. 15) along circumference of gear frame (pos. 29). Tighten screws crosswise.

Note: Turbine shaft is inserted carefully through gear wheel and stem. Note also that to secure meshing between gear wheel (pos. 7) and pinion (pos. 9) it might be necessary to rotate slightly either the whole gear subassembly or the gear wheel.

2. Replace bottom gasket (pos. 32) and bottom cover (pos. 30).
3. Mount 3/16" screws (pos. 31) and tighten crosswise.

Maintenance and Repair (continued)

Bottom Assembly

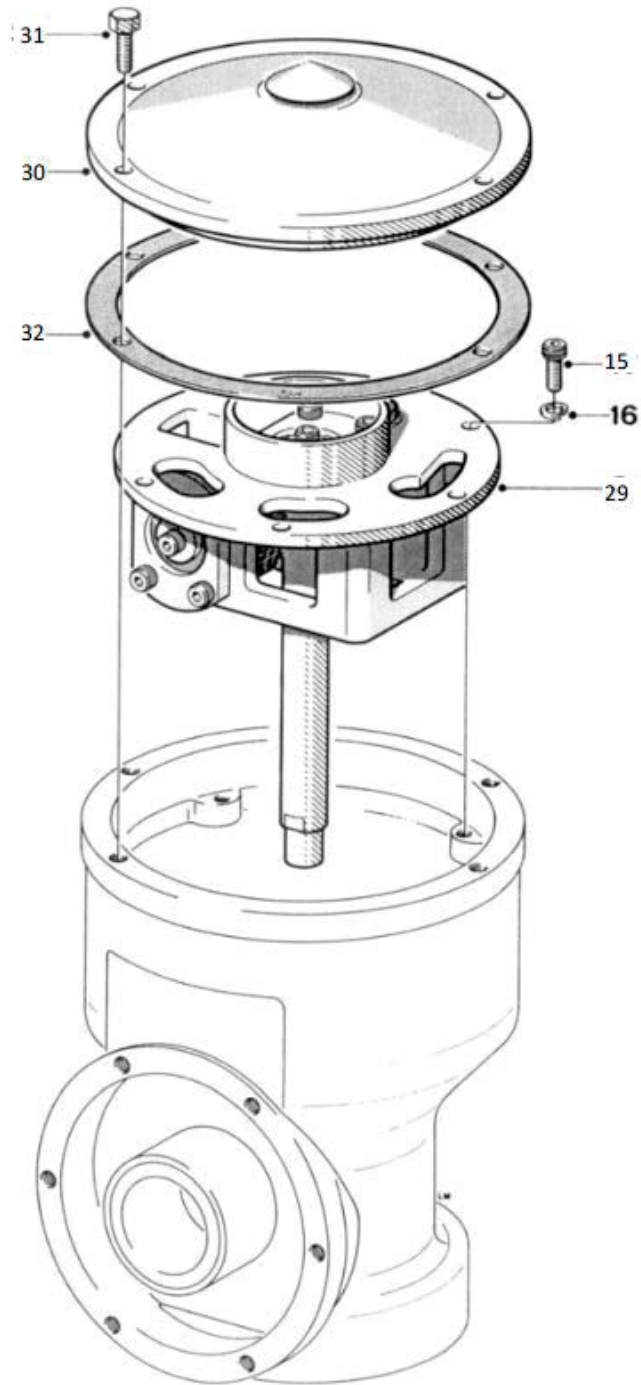

Maintenance and Repair (continued)

Hub Subassembly

Disassembly

1. Remove nozzles (pos. 20). Nozzles are untightened with a wrench on the faces of the nozzles.
2. Remove 3/16" screws (pos. 31) from hub cover (pos. 19).
3. Draw out hub (pos. 21) together with hub cover (pos. 19), ball race (pos. 26), hub gasket (pos. 25), ball retainer with balls (pos. 24) and bevel gear (pos. 18). If hub cover (pos. 19) clings into body, knock carefully with plastic hammer on outer diameter to loosen.

If ball races (pos. 18.1 and 21.1) in hub cover and in bevel gear are extremely worn, they should be replaced as well as the ball retainer with balls (pos. 24). How to replace ball races see page 36.

Reassembly

1. Slide on hub (pos. 21).
2. Mount bevel gear with race (pos. 18), ball retainer with balls (pos. 24), hub gasket (pos. 25) and hub cover (pos. 19) and set with 3/16" screw (pos. 31).
3. Screw on nozzles (pos. 20) and tighten with wrench. If desired, secure with liquid thread locker Loctite no. 243 or equivalent, see page 15-16.

Maintenance and Repair (continued)

Hub Assembly

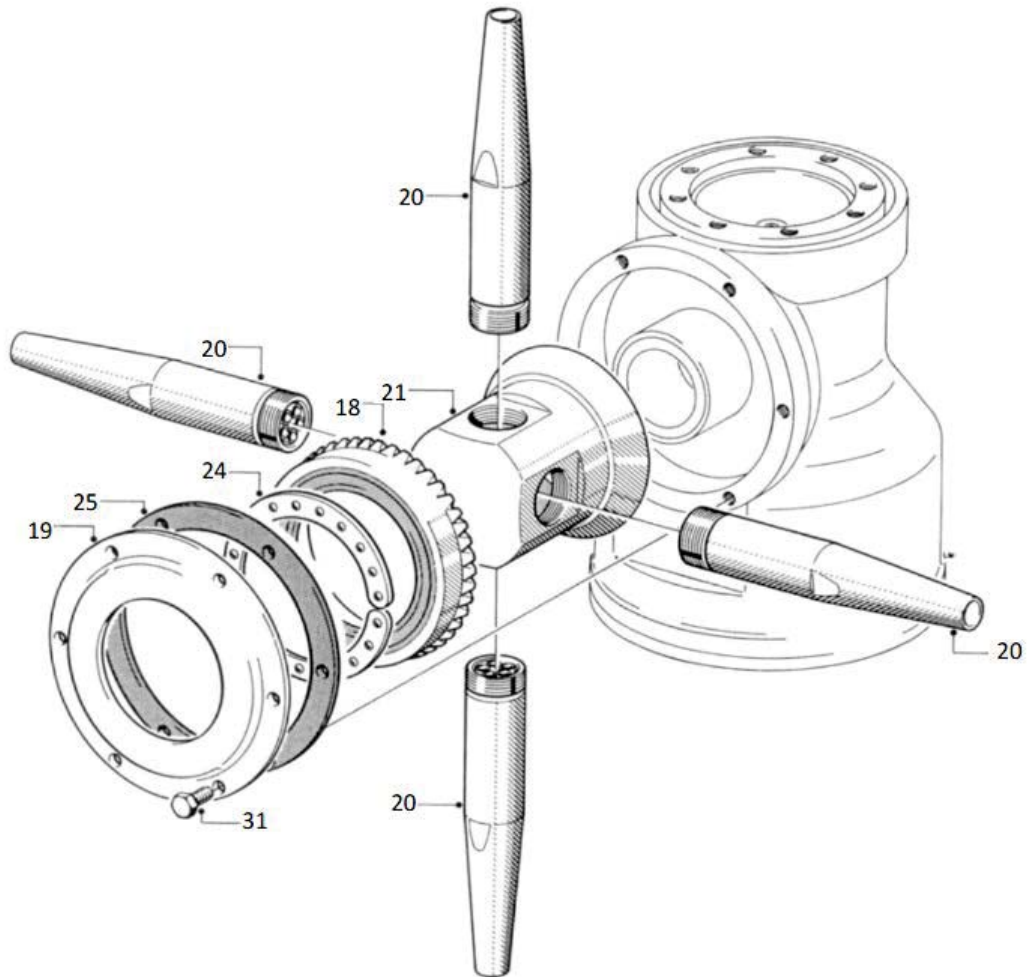

Maintenance and Repair (continued)

Stem Subassembly

Disassembly

1. Place mixer in upright position.
2. Push out main bush (pos. 5).
3. Turn mixer upside down.
4. Remove 1/4" screws (pos. 8) in gear wheel (pos. 7). To prevent rotation of stem (pos. 3) mount two 1/4" screws in two holes opposite one another in BIG end of stem. Place stem in a vice held by the heads of the two screws.
5. Draw out gear wheel with ball race (pos. 7) and ball retainer with balls (pos. 24).
6. Push out stem (pos. 3).

If ball races in body (pos. 28.3) and on gear wheel (pos. 7.1) are extremely worn they should be replaced together with ball retainer with balls (pos. 24). How to replace ball races see page 36.

Reassembly

1. Push stem into body. Turn mixer upside-down.
2. Place ball retainer with balls (pos. 24) and gear wheel (pos. 7) into body on ball race. Rotate gear wheel to check free rotation.
3. Mount gear wheel (pos. 7) with 1/4" screws (pos. 8) and tighten crosswise. To prevent rotation of stem (pos. 3) mount two 1/4" screws in two holes opposite one another in BIG end of stem. Place stem in a vice held by the heads of the two screws.
4. Turn mixer to upright position. Remount main bush (pos. 5) and screw into stem (pos. 3). Note: Left-hand thread.

Maintenance and Repair (continued)

Stem Subassembly

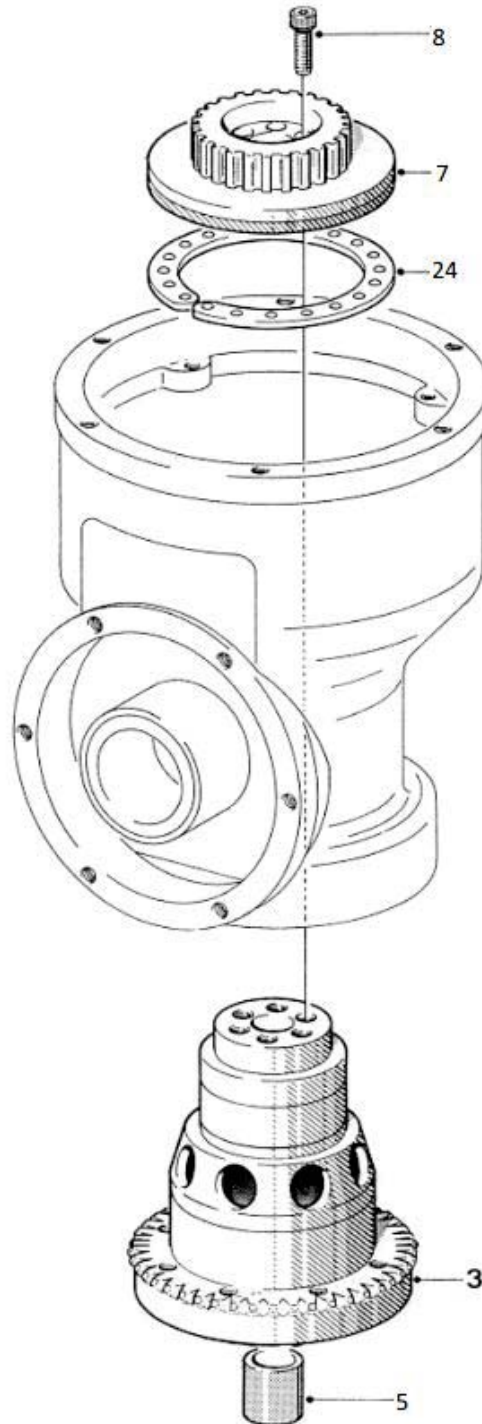

Maintenance and Repair (continued)

Gear Subassembly

Disassembly

1. Hold turbine shaft (pos. 6) against 1st stage Worm wheel (pos. 33) with one hand and loosen 3/16" screws (pos. 15) in pinion (pos. 9) and horizontal shaft (pos. 27) with the other hand.
2. Draw out turbine shaft (pos. 6) after 3/16" screw (pos. 15), spring washer (pos. 16) and washer (pos. 34) has been removed. Use faces on turbine shaft to hold against rotation.
3. Draw out horizontal shaft (pos. 27) and 1st stage worm wheel (pos. 33) after removal of 3/16" screw (pos. 15), spring washers (pos. 16) and washer (pos. 34).
4. Draw out pinion (pos. 9) and 2nd stage worm wheel (pos. 11), also freeing journal (pos. 12) after removal of 3/16" screw (pos. 15), spring washer (pos. 16) and washer (pos. 34).
5. Remove bearing covers (pos. 14) and slide bearings (pos. 28) after removal of 3/16" screw (pos. 15).

Warning

Do not damage driver faces on turbine shaft. Use only proper tools providing a firm grip such as a wrench or a vice.

How to replace collar bushes (pos. 12), see page 34.

Reassembly

1. Push slide bearing (pos. 28) into gear frame (pos. 29) and fix bearing covers (pos. 14) with 3/16" screws (pos. 15). Tighten crosswise.
2. Insert 2nd stage worm wheel (pos. 11), pinion (pos. 9) and journal (pos. 12). Mount washer (pos. 34), spring washer (pos. 16) and fix with 3/16" screw (pos. 15). Check rotation.

Note: It is important that the screw holding the pinion is fastened to a torque moment of 5 Nm, to secure it from loosening.

Maintenance and Repair (continued)

Gear Subassembly

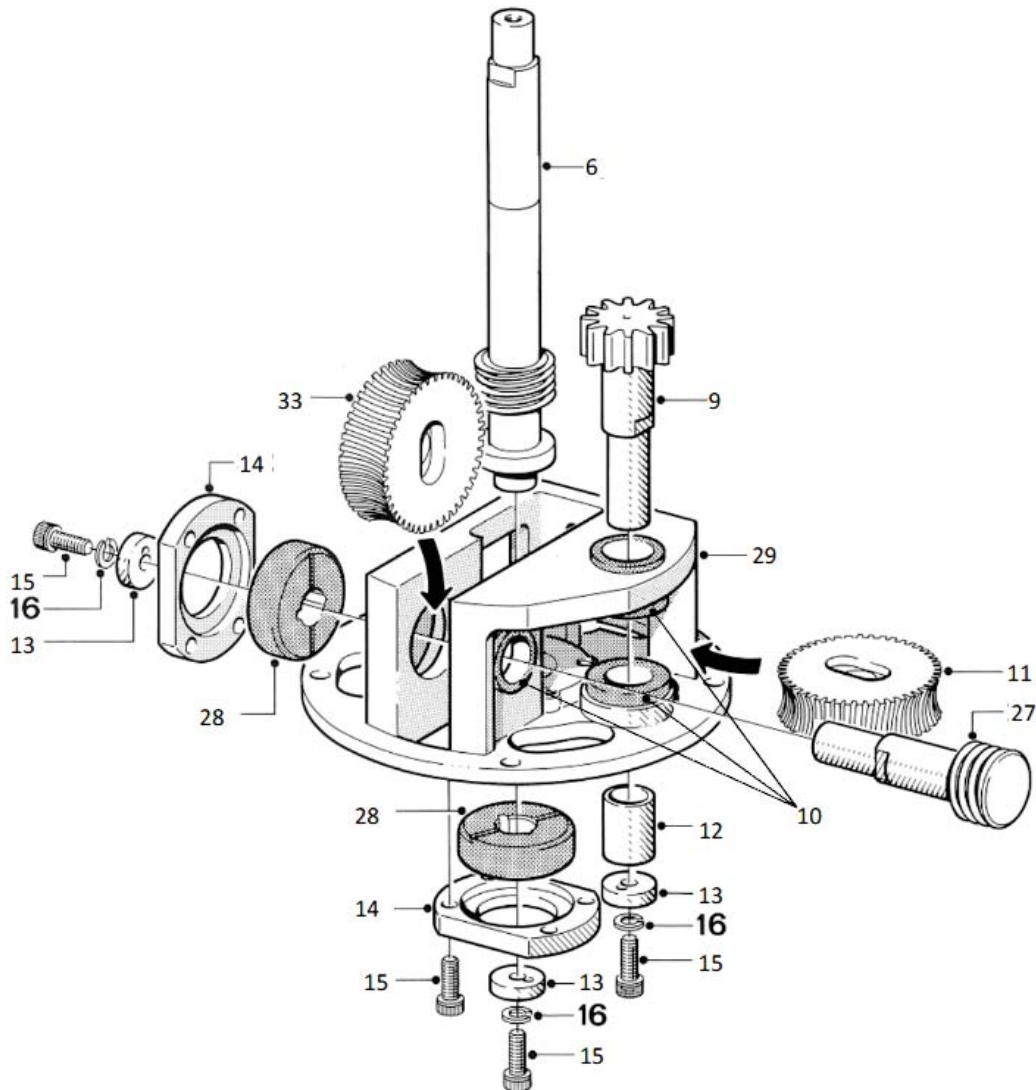

3. Insert 1st stage worm wheel (pos. 33) and horizontal shaft (pos. 27). Mount washer (pos. 34), spring washer (pos. 16) and fix with 3/16" screw (pos. 15). Check rotation.
4. Insert turbine shaft (pos. 6). Mount washer (pos. 34), spring washer (pos. 16) and fix with 3/16" screw (pos. 15). Use faces on turbine shaft to hold against rotation when tightening screw.
5. Hold turbine shaft (pos. 6) against 1st stage worm wheel and tighten 3/16" screws (pos. 15) in horizontal shaft (pos. 27) and pinion (pos. 9). Check rotation on turbine shaft.

Maintenance and Repair (continued)

Replacement of Collar Bushes

1. Place gear frame (pos. 29) upside down with a firm support under the flange. Use for instance jaws of a vice. Do not clamp on machined surfaces. With pusher (tool no. TE81B031, see page 40) knock out collar bush.
2. Turn gear frame to upright position and hold over support such as flat steel bar clamped in a vice. Knock out collar bush with pusher.
3. Turn gear frame 90° and hold over support. Knock out collar bush with pusher.

Warning



To avoid risk of deforming gear frame, it is utmost important that it is supported while the collar bushes are being knocked out.

4. Remove all remains of old Araldite etc. Holes must be perfectly clean before mounting new collar bushes. Rinse with chemical cleaner.
5. Coat new collar bushes with CIBA-GEIGY two component Standard blue Araldite and push into gear frame.
6. To hold collar bushes in correct position, insert fixtures (tool no. TE81B032, see page 40) and let harden according to instructions.

Maintenance and Repair (continued)

Replacement of Collar Bushes

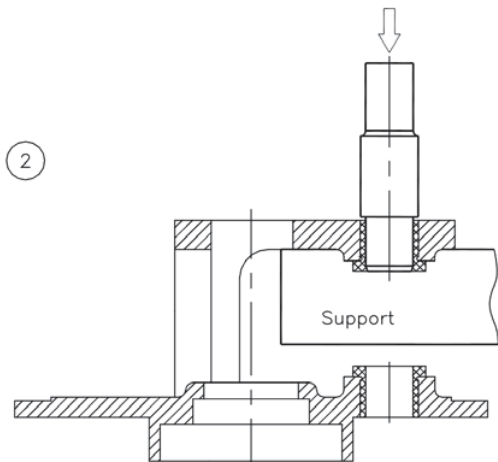
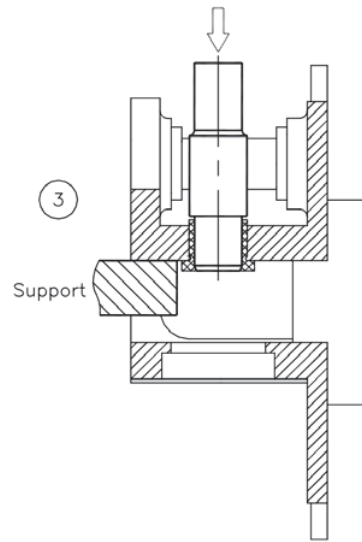
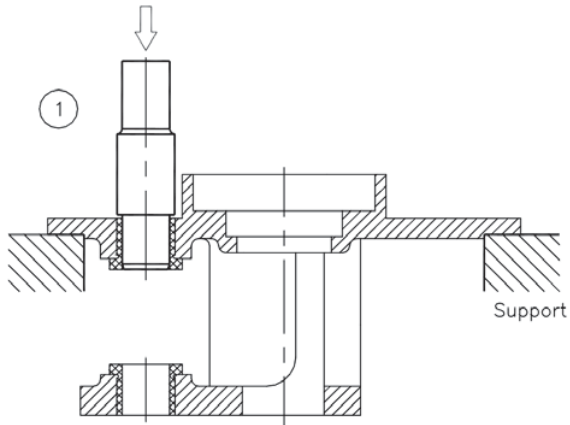

Removal of old collar bushes

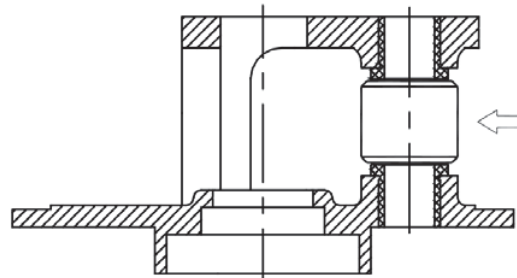
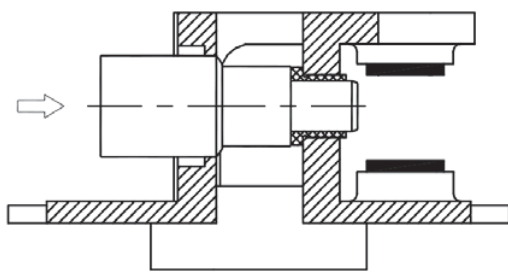

Mounting of new collar bushes

Maintenance and Repair (continued)

Replacement of Ball Races

In Body

- 1.A With big end downwards knock several times body with bearings (pos. 28) hard against firm wooden support until ball race (pos. 28.3) drops out.
- 1.B If it is not possible to knock out ball race in this way, it is necessary first to screw out main collar lower (pos. 28.2) - see page 38. Carefully push off old ball race without damaging main collar lower. Use mandrel and firm support.

Before mounting of new ball race, main collar lower (pos. 28.2) must be remounted into body - see page 38.

2. Clean surfaces and place ball race (pos. 28.3) on main collar lower (pos. 28.2). Press by hand as long as possible. By means of a tube mandrel or if desired wooden block, carefully hammer ball race home.

Ball race must not project over end face of main collar lower. To avoid tilting mandrel must push along the whole circumference of ball race. Do not damage surface of ball race.

On Gear wheel

1. Place gear wheel with ball race (pos. 7) on support. Support only under ball race (pos. 7.1). With mandrel press off old ball race.
2. Clean surfaces and press on new ball race. Ball race must be pressed fully home on gear. Press parallel. Use press or vice. Do not damage surface of ball race.

In Hub cover

1. Place hub cover with ball race (pos. 19) on support. Carefully knock out old ball race by means of small mandrel or if desired screwdriver. Knock several times around the circumference to avoid tilting.
2. Clean surfaces and press in new ball race. Ball race must be pressed fully home. Press parallel. Do not damage surface of ball race.

Maintenance and Repair (continued)

Replacement of Ball races (continued)

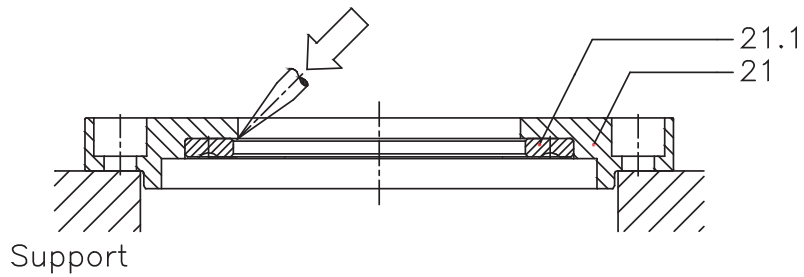
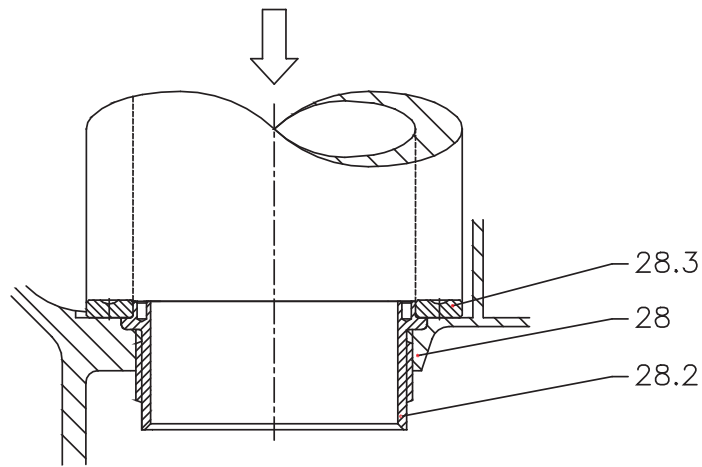
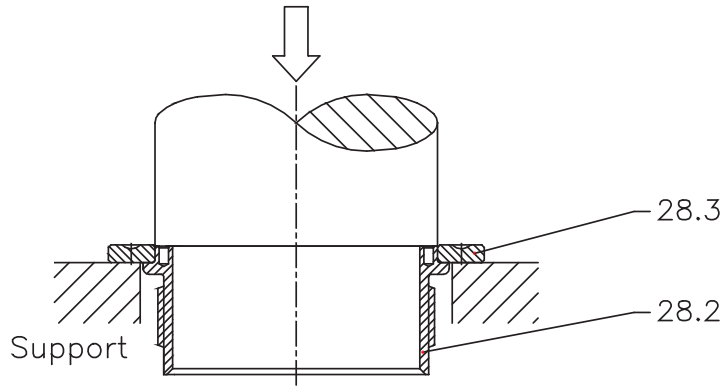

Maintenance and Repair (continued)

Replacement of Main Collars

Although normally exposed to very limited wear, it is possible to replace main collars (pos. 28.1 and 28.2) in body. The procedure to do this is described below.

Warning



Replacement of main collars involves risk of damaging the special threads and accordingly the body. It is recommended to let Rotary Jet Mixer Iso-Mix 20 do the replacement.

Main collar upper

1. Place body (pos. 28) in a vice in upright position. Do not clamp on machined faces. Insert tool (see page 40) into main collar upper (pos. 28.1). Unscrew main collar.
2. Carefully clean thread and recess in body. Do not damage special thread in body. Recess must be absolutely clean.
3. Make sure that new main collar is clean and free from impurities.
4. Screw in new main collar. Attention should be given to make sure that thread is in correct engagement before screwing in main collar.
5. Tighten main collar fully home. Several times knock hard on tool and tighten up.
6. Check that main collar is fully home: Install stem, ball retainer with balls and gear wheel (see page 30). Check that there is sufficient axial clearance to allow for free rotation of stem.

Main Collar Lower

1. Place body in a vice in upside down position and repeat procedure described above.

Warning



Thread on main collar lower is left-handed.

Maintenance and Repair (continued)

Replacement of Main Collars

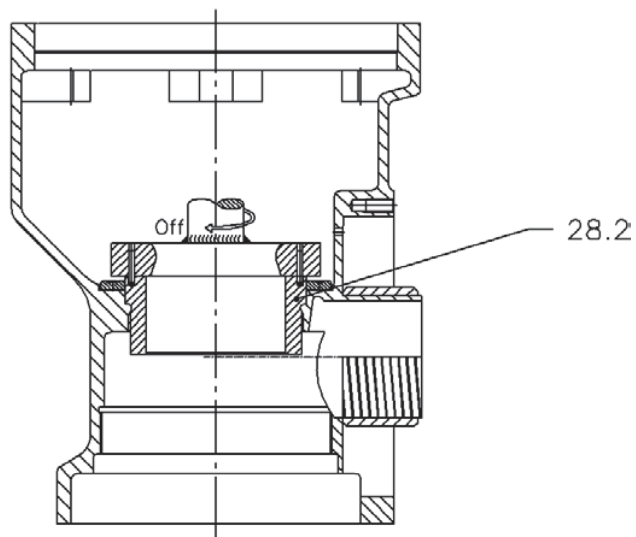
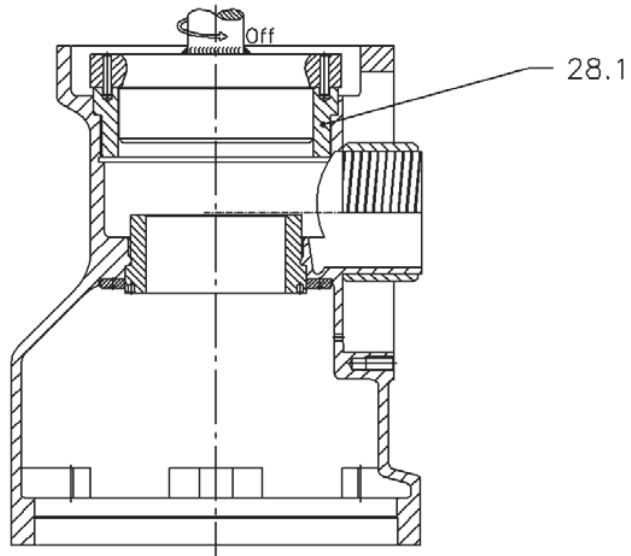

Tools

Standard Tool kit for Alfa Laval Rotary Jet Mixer Iso-Mix 20, article no. TE81B075

Tool No.	Description
TE134	Hex key for 3/16" screw (1 piece)
TE134A	Screw driver for 3/16" screw (1 piece)
TE135	Hex key for 1/4" screw (1 piece)
TE135A	Hex screwdriver 3/16" (1 piece)
TE462	Open-end spanner NV8 (1 piece)
TE962A	Socket wrench with pin (1 piece)



Sketch of Tools for replacement of Collar bush

Available on request

TE81B031: Pusher for 2" gear frame

TE81B032: Fixture set for gear frame

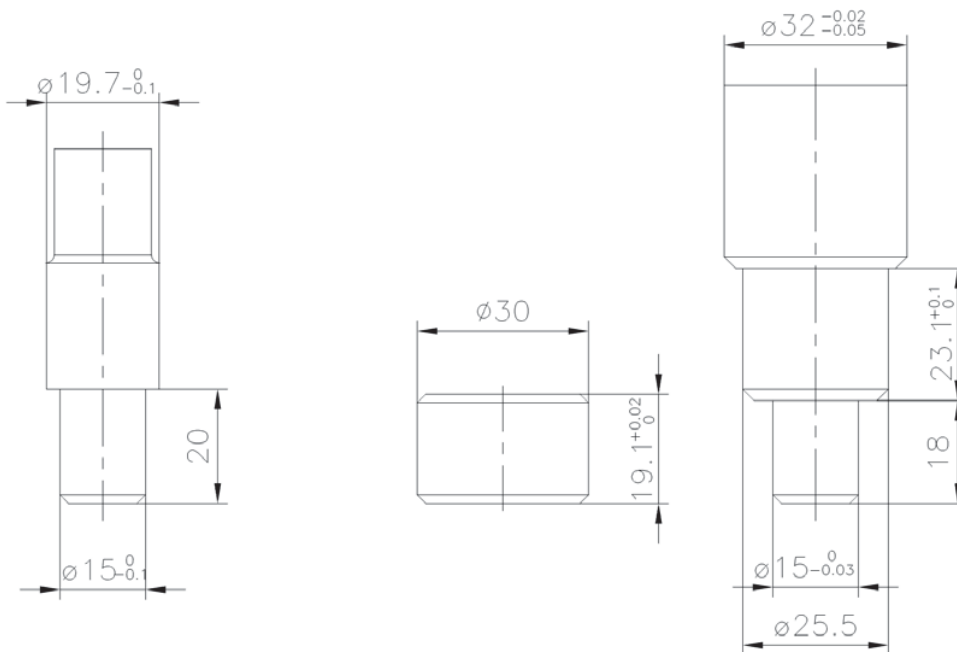

Tools (continued)

Sketch of Tools for replacement of Main collars

Available on request

TE81B131 Tool f. upper Collar (2"TCM) Compl.

TE81B132 Tool f. lower Collar (2"+3"TCM) Compl.

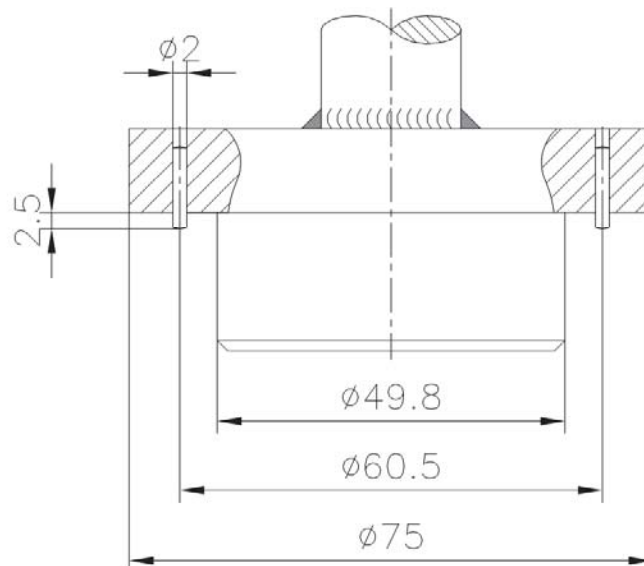
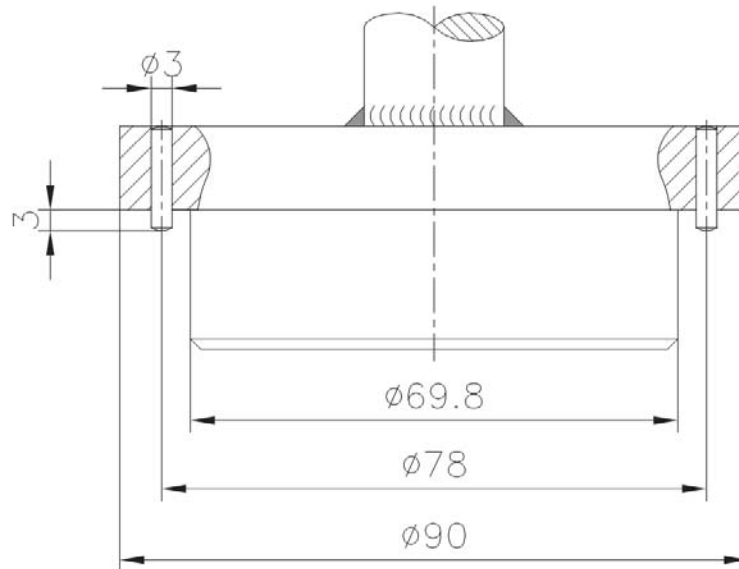

Trouble Shooting Guide

Symptom: Slow rotation or failure of the mixer to rotate

Possible causes	Action
No or insufficient liquid flow	<ul style="list-style-type: none"> a) Check if supply valve is fully open. b) Check if inlet pressure to mixer is correct. c) Check supply line/filter for restrictions/ clogging. d) Remove nozzles and check for clogging. If blocked, carefully clean nozzle without damaging stream strengtheners and nozzle tip. e) Remove top cone, guide and impeller (see page 24) and check for clogging in impeller area. f) If large particles repeatedly get jammed in the mixer, install filter or reduce mesh size of installed filter in supply line.
Foreign Material or Material Build-up	<p>Insert Hex screwdriver in screw in top of turbine shaft and easily turn turbine shaft clockwise. If any resistance is recognized, disassemble mixer to localize the cause:</p> <ul style="list-style-type: none"> a) Impeller jammed Remove guide and impeller (see page 24) and remove foreign material. b) Turbine shaft sluggish in main bush Remove gear subassembly (see page 26) and clean main bush. c) Bevel gears jammed Remove top cone and hub subassembly (see page 28). Clean teeth on stem and bevel gear. d) Stem jammed/sluggish Remove gear subassembly (see page 26). Check free rotation of stem. Remove stem (see page 30). Remove foreign material/material build-up on stem and inside main collars. Clean ball races and ball retainer with balls. Also clean main bush.

Trouble Shooting Guide (continued)

Possible causes	Action
e) Gearbox jammed/sluggish	Remove foreign material from gearbox. Check rotation of shafts. If restriction is recognized, disassemble gearbox (see page 32) and remove material build-up, especially on 2 nd stage worm wheel and mating collar bushes.
f) Hub jammed/sluggish	Disassemble hub subassembly (see page 28). Remove foreign material inside hub. Clean ball races and ball retainer with balls. Also clean nose of body.

Wear

a) Slide bearings	See page 22.
b) Main bush	See page 23.
c) Worm wheels	See page 23.
d) Collar bushes	See page 22.
e) Turbine shaft	Check clearance in main bush and in slide bearing. Transverse movement should not exceed 0.5 mm. Also inspect worm wheel for wear.
f) Horizontal shaft	Check clearance in collar bushes. Transverse movement should not exceed 0.5 mm. Also inspect worm for wear.

Mechanical defects

a) Worm wheel/teeth broken	Replace worm wheel.
b) Worm wheel can rotate on horizontal shaft/pinion due to damaged driver faces	Replace worm wheel.
c) Damaged teeth on bevel gear	Inspect teeth on stem and bevel gear for deformation. Mount hub and stem in body (see page 28 and 30). Hold body in upside down position and rotate hub to check that bevel gears can work together. If damaged: Replace stem and/or bevel gear.

IM 20 Rotary Jet Mixer with 4 nozzles

Reference list of parts

Pos.	Ref. no.	No./ unit	Description	Material	Remarks
1	<input type="checkbox"/> TE22D500	1	Top cone 2" BSP	Stainless steel	Spare part
	<input type="checkbox"/> TE22D501	1	Top cone 2" NPT	Stainless steel	Spare part
2	<input type="checkbox"/> TE603	1	Guide 100%	Stainless steel	Spare part
	<input type="checkbox"/> TE103-0	1	Guide ring 0%	Stainless steel	Spare part
3	TE32B526	1	Stem	Stainless steel	Spare part
4	TE32B508	1	Impeller 100%	Stainless steel	Spare part
5	TE32B576	1	Main bush	Polymer	Wear part
6	TE32B511	1	Turbine shaft	Stainless steel	Wear part
7	TE32B303	1	Gear wheel w. ball race	Stainless steel	Spare part
7.1	TE32B510		Ball race	Stainless steel	Wear part
8	TE120	6	Screw	Stainless steel	Spare part
9	TE114	1	Pinion	Stainless steel	Spare part
10	TE22A586	3	Collar bush	Polymer	Wear part
11	<input type="checkbox"/> TE22A365	1	Worm wheel w. reinforcement	Polymer	Wear part
	<input type="checkbox"/> TE22A364	1	Worm wheel E-gear	Polymer	Wear part
12	TE117	1	Journal	Stainless steel	Spare part
13	TE619A	3	Washer	Stainless steel	Spare part
14	TE531	2	Bearing cover	Stainless steel	Spare part
15	TE118	17	Screw	Stainless steel	Spare part
16	TE156	9	Spring washer	Stainless steel	Spare part
17	TE902H	8	Screw	Stainless steel	Spare part
18	TE32B307	1	Bevel gear with ball race	Stainless steel	Spare part
18.1	TE32B510		Ball race	Stainless steel	Wear part
19	TE32B306	1	Hub cover with ball race	Stainless steel	Spare part
19.1	TE32B510		Ball race	Stainless steel	Wear part
20	<input type="checkbox"/> TE50B008	4	Nozzle, ø8	Stainless steel	Spare part
	<input type="checkbox"/> TE50B009	4	Nozzle, ø9	Stainless steel	Spare part
	<input type="checkbox"/> TE50B010	4	Nozzle, ø10	Stainless steel	Spare part
	<input type="checkbox"/> TE50B011	4	Nozzle, ø11	Stainless steel	Spare part
21	TE32B536	1	Hub for 4 nozzle	Stainless steel	Spare part
24	TE32B302	2	Ball retainer with balls	Polymer/ceramics	Wear part
25	TE22D553	1	Hub gasket	Polymer/Elastomer	Spare part
26		1	Body	Stainless steel	Not available
26.1	TE32B577	1	Main collar upper	Polymer	Wear part
26.2	TE32B578	1	Main collar lower	Polymer	Wear part
26.3	TE32B510		Ball race	Stainless steel	Wear part
26.4	TE32B575	1	Hub collar	Polymer	Wear part
27	<input type="checkbox"/> TE128Z	1	Horizontal shaft	Stainless steel	Wear part
	<input type="checkbox"/> TE128E	1	Horizontal shaft E-gear	Stainless steel	Wear part
28	TE22A571	2	Slide bearing	Polymer	Wear part
29	TE630	1	Gear frame	Stainless steel	Spare part
30	TE32B350	1	Bottom cover, compl.	Stainless steel	Spare part
31	TE421H	12	Screw	Stainless steel	Spare part
32	TE22D554	1	Bottom gasket	Polymer/Elastomer	Spare part
33	TE22A365	1	Worm wheel w. reinforcement	Polymer/Stainless steel	Wear part
34	TE32B515	1	Washer	Stainless steel	Spare part

Possible configurations marked

Please note that some of the polymer parts are in PEEK. PEEK is not resistant to concentrated sulfuric acid.

IM 20 Rotary Jet Mixer with 4 nozzles

Cross Sectional Drawing

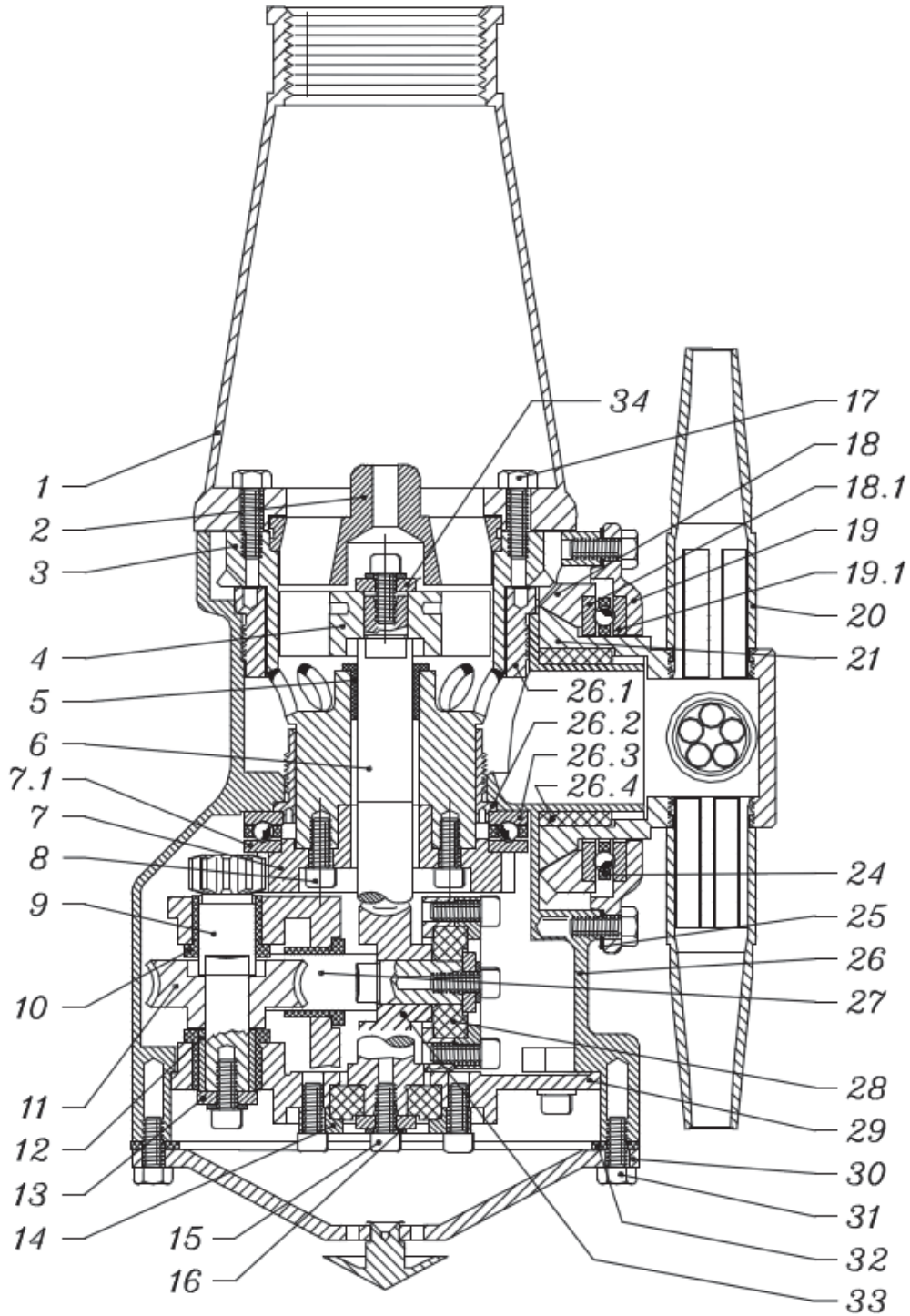

IM 20 Rotary Jet Mixer with 2 nozzles

Reference List of Parts

Pos.	Ref. no.	No./ unit	Description	Material	Remarks
1	<input type="checkbox"/> TE22D500	1	Top cone 2" BSP	Stainless steel	Spare part
	<input type="checkbox"/> TE22D501	1	Top cone 2" NPT	Stainless steel	Spare part
2	<input type="checkbox"/> TE103-0	1	Guide ring 0%	Stainless steel	Spare part
3	TE32B526	1	Stem	Stainless steel	Spare part
4	TE32B508	1	Impeller 100%	Stainless steel	Spare part
5	TE32B576	1	Main bush	Polymer	Wear part
6	TE32B511	1	Turbine shaft	Stainless steel	Wear part
7	TE32B303	1	Gear wheel w. ball race	Stainless steel	Spare part
7.1	TE32B510		Ball race	Stainless steel	Wear part
8	TE120	6	Screw	Stainless steel	Spare part
9	TE114	1	Pinion	Stainless steel	Spare part
10	TE22A586	3	Collar bush	Polymer	Wear part
11	<input type="checkbox"/> TE22A365	1	Worm wheel	Polymer	Wear part
	<input type="checkbox"/> TE22A364	1	Worm wheel E-gear	Polymer	Wear part
12	TE117	1	Journal	Stainless steel	Spare part
13	TE156	9	Spring washer	Stainless steel	Spare part
14	TE531	2	Bearing cover	Stainless steel	Spare part
15	TE118	17	Screw	Stainless steel	Spare part
16	TE619A	3	Washer	Stainless steel	Spare part
17	TE902H	8	Screw	Stainless steel	Spare part
18	TE32B307	1	Bevel gear with ball race	Stainless steel	Spare part
18.1	TE32B510		Ball race	Stainless steel	Wear part
19	TE32B306	1	Hub cover with ball race	Stainless steel	Spare part
19.1	TE32B510		Ball race	Stainless steel	Wear part
20	<input type="checkbox"/> TE50C012	2	Nozzle, ø12	Stainless steel	Spare part
	<input type="checkbox"/> TE50C013	2	Nozzle, ø13	Stainless steel	Spare part
	<input type="checkbox"/> TE50C014	2	Nozzle, ø14	Stainless steel	Spare part
	<input type="checkbox"/> TE50C015	2	Nozzle, ø15	Stainless steel	Spare part
21	TE32B534	1	Hub conical part	Stainless steel	Spare part
22	TE448	1	Cotter pin	Stainless steel	Wear part
23	TE624-2-15	1	Hub nozzle part for 2 nozzle	Stainless steel	Wear part
24	TE32B302	2	Ball retainer with balls	Polymer/ceramics	Wear part
25	TE22D553	1	Hub gasket	Polymer/Elastomer	Spare part
26		1	Body	Stainless steel	Not available
26.1	TE32B577	1	Main collar upper	Polymer	Wear part
26.2	TE32B578	1	Main collar lower	Polymer	Wear part
26.3	TE32B510		Ball race	Stainless steel	Wear part
26.4	TE32B575	1	Hub collar	Polymer	Wear part
27	<input type="checkbox"/> TE128Z	1	Horizontal shaft	Stainless steel	Wear part
	<input type="checkbox"/> TE128E	1	Horizontal shaft E-gear	Stainless steel	Wear part
28	TE22A571	2	Slide bearing	Polymer	Wear part
29	TE630	1	Gear frame	Stainless steel	Spare part
30	TE32B350	1	Bottom cover, compl.	Stainless steel	Spare part
31	TE421H	12	Screw	Stainless steel	Spare part
32	TE22D554	1	Bottom gasket	Polymer/Elastomer	Spare part
33	TE22A365	1	Worm wheel	Polymer	Wear part
34	TE32B515	1	Washer	Stainless steel	Spare part

Possible configurations marked

Please note that some of the polymer parts are in PEEK. PEEK is not resistant to concentrated sulfuric acid.

IM 20 Rotary Jet Mixer with 2 nozzles

Cross sectional drawing

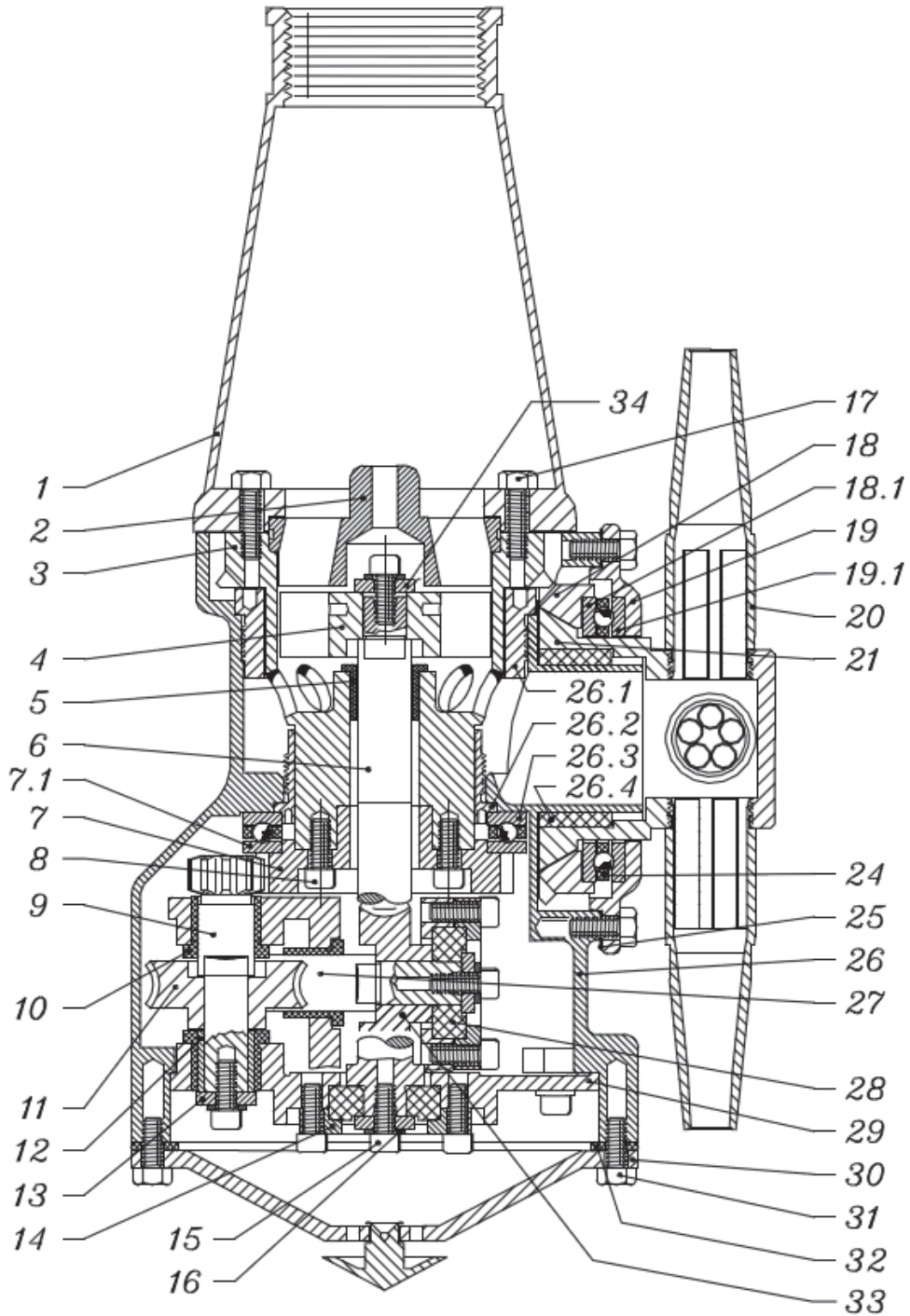

Service intervals

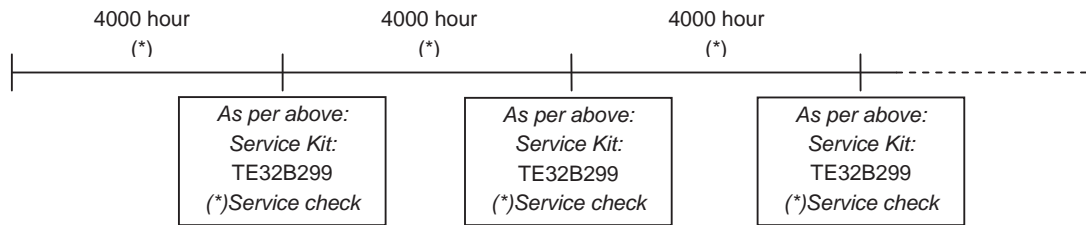

*** Note:** The service intervals are recommended on the basis of pure liquids. When liquids contain particles and other kind of abrasives, we recommend shorter service intervals depending on the actual running conditions.

Standard Spare Part Service Kits and Tool Kits

Standard Spare Part Service Kit for IM 20 Rotary Jet Mixer, Article No. TE32B299

Part No.	Description	No.
TE128Z	Horizontal shaft	1 pc.
TE22A365	Worm wheel w. reinforcement	2 pcs.
TE22A571	Slide bearing	2 pcs.
TE22A586	Collar bush	3 pcs.
TE22B576	Main bush	1 pc.
TE32B302	Ball retainer with balls	2 pcs.
TE32B510	Ball race	4 pcs.
TE32B511	Turbine shaft	1 pc.

Standard Tool Kit for IM 20 Rotary Jet Mixer, Article No. TE81B075

Part No.	Description	No.
TE134	Hex key for 3/16" screw	1 pc.
TE134A	Screw driver for 3/16"screw	1 pc.
TE135	Hex key for 1/4"screw	1 pc.
TE135A	Hex screwdriver 3/16"	1 pc.
TE462	Open-end spanner NV8	1 pc.
TE962A	11mm Socket Wrench w.pin	1 pc.

Special Tools for IM 20 Rotary Jet Mixer

Available on request:

Part No.	Description	No.
TE81B031	Pusher for Collar bush	1 pc.
TE81B032	Fixture set for Collar bush	1 pc.
TE81B131	Tool f. upper Collar (2"TCM) Compl.	1 pc.
TE81B132	Tool f. lower Collar (2"+3"TCM) Compl.	1 pc.

General information

How to Order Spare Parts

On the Cross Sectional Drawing as well as on all instruction drawings, the individual parts have a pos. number which is the same on all drawings. From the pos. number, the part is easily identified in the Reference list of Parts, page 44.

Individual parts should always be ordered from the Reference list of parts. Reference number and description should be clearly stated.

Please also quote the type of mixer and serial number. This will help us to help you. The type and serial number are stamped on the body of the Rotary Jet Mixer Iso-Mix 20.

Service and Repair

Upon every return of a product, no matter if for modifications or repair, it is necessary to contact your local Alfa Laval office to guarantee a quick execution of your request.

You will receive instructions regarding the return procedure from your local Alfa Laval office. Be sure to follow the instructions closely.

How to contact Alfa Laval Tank Equipment

For further information please feel free to contact:

Alfa Laval Tank Equipment

Alfa Laval Kolding A/S

31, Albuen - DK 6000 Kolding - Denmark

Registration number: 30938011

Tel switchboard: +45 79 32 22 00 - Fax switchboard: +45 79 32 25 80

www.toftejorg.com , www.alfalaval.dk - info.dk@alfalaval.com

Contact details for all countries are continually updated on our websites.



How to contact Alfa Laval

Contact details for all countries are continually updated on our website.

Please visit www.alfalaval.com to access the information directly.

© Alfa Laval Corporate AB

This document and its contents is owned by Alfa Laval Corporate AB and protected by laws governing intellectual property and thereto related rights. It is the responsibility of the user of this document to comply with all applicable intellectual property laws. Without limiting any rights related to this document, no part of this document may be copied, reproduced or transmitted in any form or by any means (electronic, mechanical, photocopying, recording, or otherwise), or for any purpose, without the expressed permission of Alfa Laval Corporate AB. Alfa Laval Corporate AB will enforce its rights related to this document to the fullest extent of the law, including the seeking of criminal prosecution.