

Instruction Manual

LKH Multi-Stage Pump

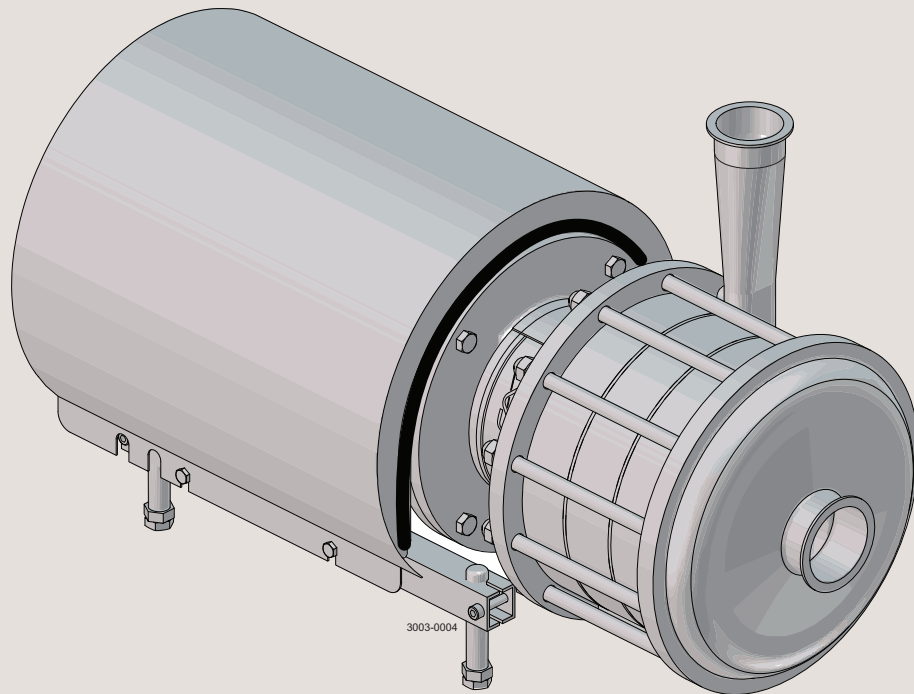



CSI

CONTACT CSI FOR MORE INFORMATION | CSIDESIGNS.COM | SALES@CSIDESIGNS.COM | 417.831.1411

Table of contents

The information herein is correct at the time of issue but may be subject to change without prior notice

1. EC Declaration of Conformity	4
2. Safety	5
2.1. Important information	5
2.2. Warning signs	5
2.3. Safety precautions	6
3. Installation	7
3.1. Unpacking/delivery	7
3.2. Installation/Pre-use Check	8
3.3. Recycling information	10
4. Operation	11
4.1. Operation/Control	11
4.2. Trouble shooting	13
4.3. Recommended cleaning	14
5. Maintenance	15
5.1. General maintenance	15
5.2. Cleaning Procedure	16
5.3. Dismantling of pump/shaft seals	17
5.4. Assembly of Pump/Assembly of Shaft Seal - LKH-110	21
5.5. Assembly of Pump/Assembly of Shaft Seal - LKH-120/P	27
6. Technical data	32
6.1. Technical data	32
6.2. Relubrication intervals	33
6.3. Torque Specifications	34
6.4. Weight (kg)	35
6.5. Noise emission	36
7. Parts list and service kits	37
7.2. LKH Multi-Stage - Wet end	38
7.3. LKH Multi-Stage - Motor dependent parts	40
7.4. LKH Multi-Stage - Shaft seal and Service kits	42



CSI

CONTACT CSI FOR MORE INFORMATION | CSIDESIGNS.COM | SALES@CSIDESIGNS.COM | 417.831.1411

1 EC Declaration of Conformity

Revision of Declaration of Conformity 2009-12-29

The Designated Company

Alfa Laval Kolding A/S

Company Name

Albuen 31, DK-6000 Kolding, Denmark

Address

+45 79 32 22 00

Phone No.

hereby declare that

Pump

Designation

LKH-112, LKH-112/P, LKH-113, LKH-113/P, LKH-114, LKH-114/P, LKH-122/P, LKH-123/P, LKH-124/P

Type

From serial number 10.000 to 1.000.000

is in conformity with the following directive with amendments:

- Machinery Directive 2006/42/EC

The person authorised to compile the technical file is the signer of this document

Global Product Quality Manager
Pump, Valves, Fittings and Tank Equipment

Title

Lars Kruse Andersen

Name

Kolding
Place

2013-12-03
Date

Signature



*Unsafe practices and other important information are emphasized in this manual.
Warnings are emphasized by means of special signs.
Always read the manual before using the pump!*

2.1 Important information

WARNING

Indicates that special procedures must be followed to avoid serious personal injury.

CAUTION

Indicates that special procedures must be followed to avoid damage to the pump.

NOTE

Indicates important information to simplify or clarify procedures.

2.2 Warning signs

General warning:



Dangerous electrical voltage:



Caustic agents:



2 Safety

All warnings in the manual are summarized on this page.

Pay special attention to the instructions below so that severe personal injury and/or damage to the pump are avoided.

2.3 Safety precautions

Installation:

Always read the technical data thoroughly. (See chapter 6 Technical data)

ALways use a lifting crane when handling the pump

Always use a lifting crane when handling the pump.

Never start in the wrong direction of rotation with liquid in the pump.



Always have the pump electrically connected by authorized personnel. (See the motor instruction)



Operation:

Always read the technical data thoroughly. (See chapter 6 Technical data)

Never touch the pump or the pipelines when pumping hot liquids or when sterilising.

Never run the pump with both the suction side and the pressure side blocked.

Never run the pump when partially installed or not completely assembled.

Necessary precautions must be taken if leakage occurs as this can lead to hazardous situations.



Always handle lye and acid with great care.

Never use the pump for products not mentioned in Alfa Laval pump selection program.



Alfa Laval pump selection program can be acquired from your local Alfa Laval sales company.

Maintenance:

Always read the technical data thoroughly. (See chapter 6 Technical data)

Never service the pump when it is hot.

Never service the pump if pressurized.



Motors with grease nipples:

Remember lubrication according to information plate/label on the motor.

Always disconnect the power supply when servicing the pump.



Always use Alfa Laval genuine spare parts.

Transportation:

Transportation of the pump or the pump unit:

Never lift or elevate in any way other than described in this manual

Always drain the pump head and accessories of any liquid

Always ensure that no leakage of lubricants can occur

Always transport the pump in it's upright position

Always ensure that the unit is securely fixed during transportation

Always use original packaging or similar during transportation



CSI

CONTACT CSI FOR MORE INFORMATION | CSIDESIGNS.COM | SALES@CSIDESIGNS.COM | 417.831.1411

The LKH-110 and -120P pump is highly efficient and economical centrifugal pump, which meets the requirements of sanitary and gently product treatment and chemical resistance. LKH-110 and the LKH-120P is available in the following sizes, LKH-112, -113, -114 and LKH122/P, -123/P, -124/P. The instruction manual is part of the delivery. Study the instructions carefully. The large pump sizes are very heavy. ALfa Laval recommends the use of a lifting crane when handling the pump.

3.1 Unpacking/delivery

Step 1



Always use a lifting crane when handling the pump

CAUTION

Alfa Laval cannot be held responsible for incorrect unpacking.

WARNING:

Be aware that certain pump configurations can tilt, and thereby cause injuries to feet or fingers. The pump should be supported underneath the adaptor, when not installed in the process line.

Check the delivery for:

1. Complete pump.
2. Delivery note.
3. Instruction manual.
4. Motor instructions.
5. Test certificate, IF ORDERED!

Step 2

Remove possible packing materials from the inlet and the outlet. Avoid damaging the inlet and the outlet. Avoid damaging the connections for flushing liquid, if supplied.

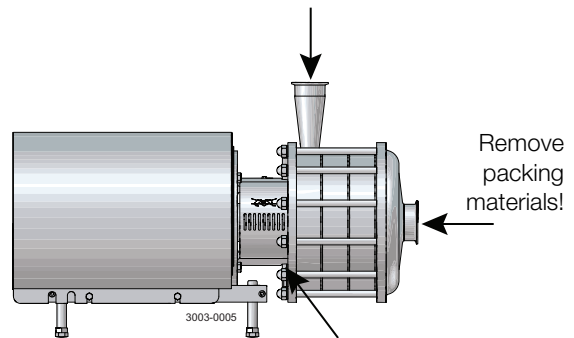

Step 3

Inspect the pump for visible transport damages.

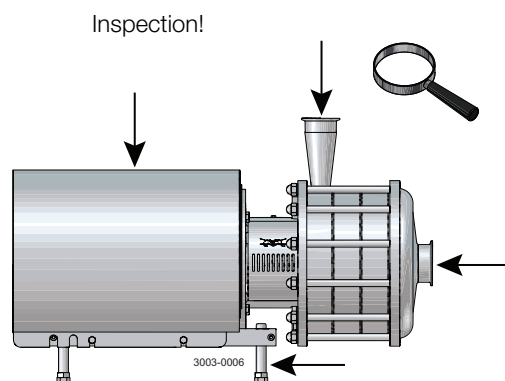

Step 4

Always remove the shroud, if fitted, before lifting the pump.

Remove the shroud before lifting!

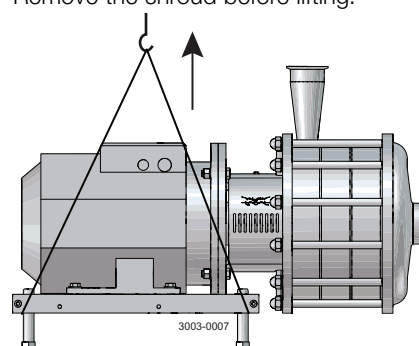

3 Installation

Study the instructions carefully and pay special attention to the warnings!

The direction of rotation of the impeller can be checked by observing the direction of rotation of the motor fan. - See the indication label on the pump.

3.2 Installation/Pre-use Check

Step 1



Always read the technical data thoroughly. (See technical data on page 32)

Never start in the wrong direction of rotation with liquid in the pump. (See Pre-use check on page 9)



Always have the pump electrically connected by authorised personnel. (See the motor instructions).

CAUTION

Alfa Laval cannot be held responsible for incorrect installation.

WARNING:

Alfa Laval recommend the installation of lockable repair breaker. If the repair breaker is to be used as an emergency stop the colors of the repair breaker must be red and yellow.

Caution:

The pump does not prevent back flow when intentionally or unintentionally stopped. If back flow can cause any hazardous situations precautions must be taken e.g. check valve to be installed in the system preventing above described.

Step 2

Ensure at least 0.5 m (1.6 ft) clearance around the pump.

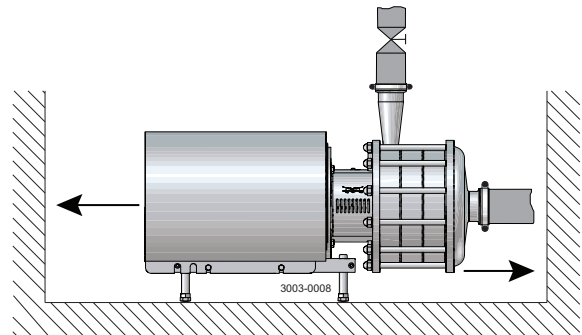

Step 3

Check that the flow direction is correct.

O: Outlet

I: Inlet

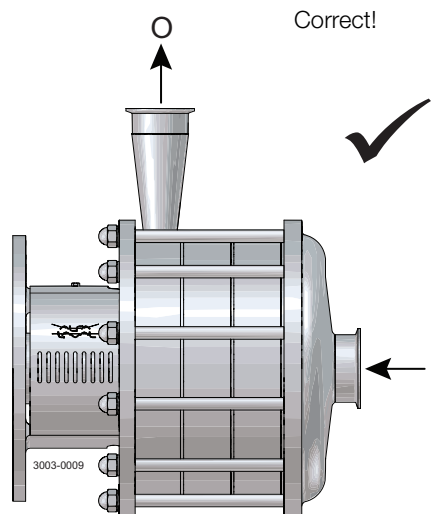

CSI

CONTACT CSI FOR MORE INFORMATION | CSIDESIGNS.COM | SALES@CSIDESIGNS.COM | 417.831.1411

3 Installation

Study the instructions carefully and pay special attention to the warnings!

The direction of rotation of the impeller can be checked by observing the direction of rotation of the motor fan. - See the indication label on the pump.

Step 4

1. Ensure that the pipelines are routed correctly.
2. Ensure that the connections are tight.

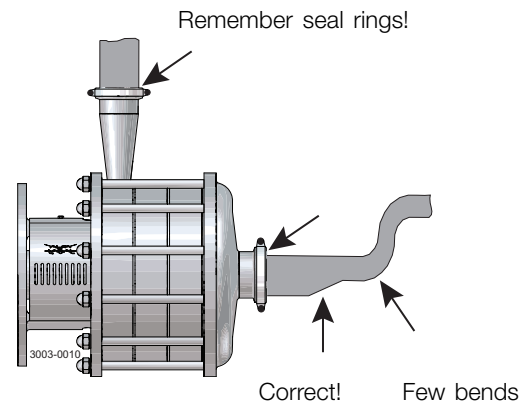

Step 5

Avoid stressing the pump.

Pay special attention to:

- Vibrations.
- Thermal expansion of the tubes.
- Excessive welding.
- Overloading of the pipelines.

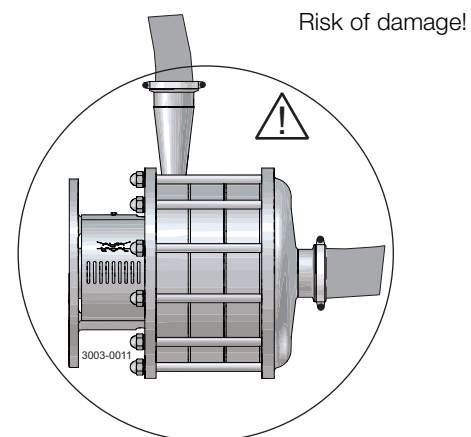

Step 6

Pre-use check:

1. Start and stop the motor momentarily.
2. Ensure that the direction of rotation of the motor fan is clockwise as viewed from the back of the motor.

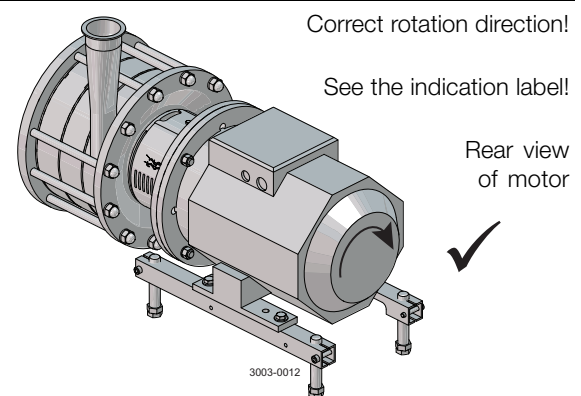

Note

In case of shaft seal leakage the media will drip from the slot in the bottom of the adaptor. In case of shaft seal leakage Alfa Laval recommend to put a drip tray underneath the slot for collecting the leakage.

3 Installation

3.3 Recycling information

- **Unpacking**

- Packing material consists of wood, plastics, cardboard boxes and in some cases metal straps.
- Wood and cardboard boxes can be reused, recycled or used for energy recovery.
- Plastics should be recycled or burnt at a licensed waste incineration plant.
- Metal straps should be sent for material recycling.

- **Maintenance**

- During maintenance oil and wear parts in the machine are replaced.
- All metal parts should be sent for material recycling.
- Worn out or defective electronic parts should be sent to a licensed handler for material recycling.
- Oil and all non metal wear parts must be taken care of in agreement with local regulations.

- **Scrapping**

- At end of use, the equipment shall be recycled according to relevant, local regulations. Beside the equipment itself, any hazardous residues from the process liquid must be considered and dealt with in a proper manner. When in doubt, or in the absence of local regulations, please contact the local Alfa Laval sales company.
-

Study the instructions carefully and pay special attention to the warnings!

4.1 Operation/Control

Step 1



Always read the technical data thoroughly. See technical data on page 32

CAUTION

Alfa Laval cannot be held responsible for incorrect operation/control.



Never touch the pump or the pipelines when pumping hot liquids or when sterilising.

Step 2



Never touch the pump or the pipelines when pumping hot liquids or when sterilising.

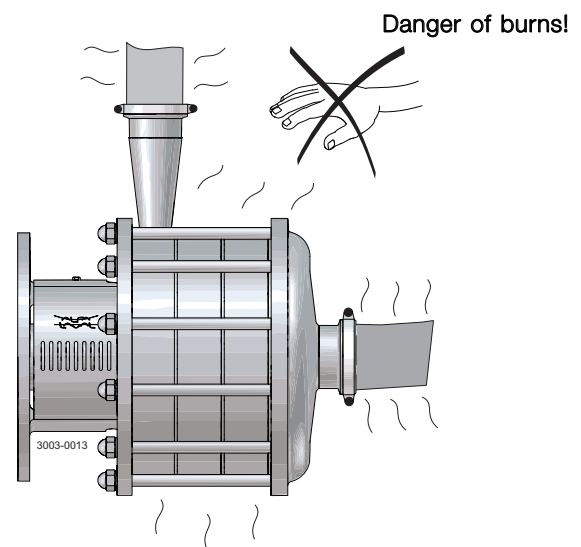

Step 3



Never run the pump with both the suction side and the pressure side blocked.

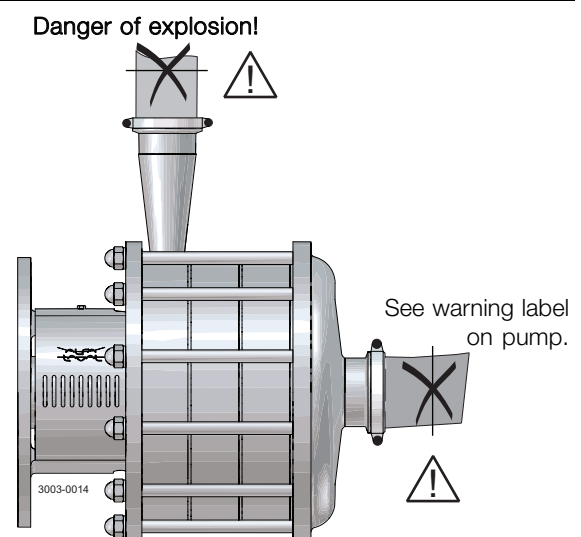

4 Operation

Study the instructions carefully and pay special attention to the warnings!

Step 4

CAUTION

The shaft seal must not run dry.

CAUTION

Never throttle the inlet side.

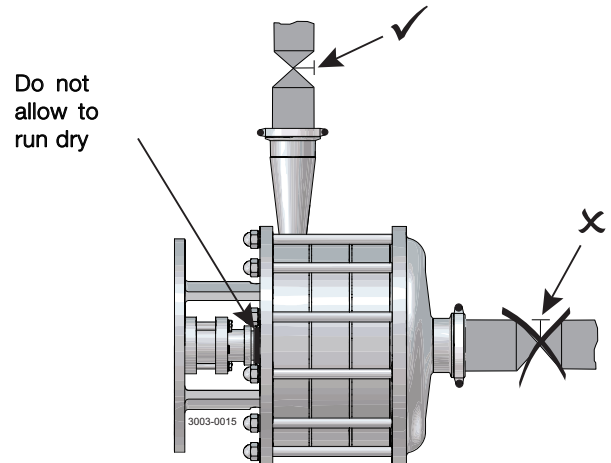

Step 5

Flushed shaft seal:

1. Connect the inlet of the flushing liquid correctly.
2. Regulate the water supply correctly.
3. Observe the steam data.

O: Outlet
I: Inlet

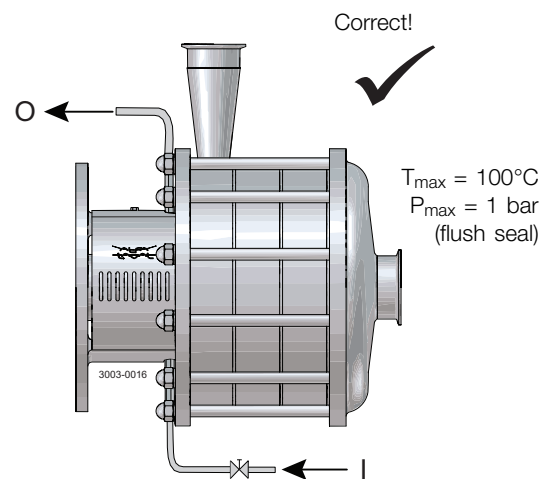

Step 6

Control:

Reduce the capacity and the power consumption by means of:

- Throttling the pressure side of the pump.
- Reducing the impeller diameter.
- Reducing the speed of the motor.

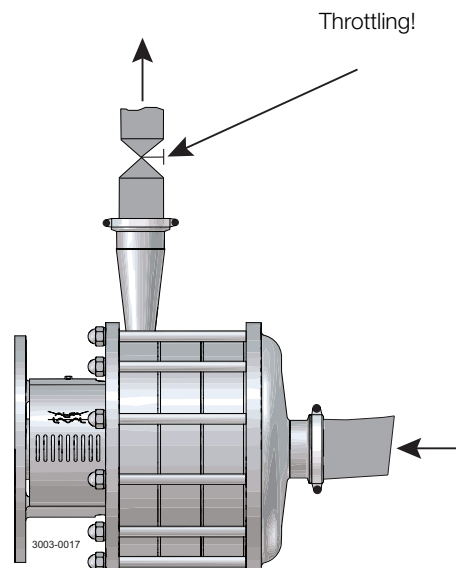

Pay attention to possible faults.
Study the instructions carefully.

4.2 Trouble shooting

NOTE!

Study the maintenance instructions carefully before replacing worn parts. - See section 5.1 General maintenance on page 15

Problem	Cause/result	Remedy
Overloaded motor	<ul style="list-style-type: none"> - Pumping of viscous liquids - Pumping of liquids with high density - Low outlet pressure (counter pressure) - Lamination of precipitates from the liquid 	<ul style="list-style-type: none"> - Larger motor or smaller impeller - Higher counter pressure (throttling) - Frequent cleaning
<ul style="list-style-type: none"> - Damage - Pressure reduction (sometimes to zero) - Increasing of the noise level 	<ul style="list-style-type: none"> - Low inlet pressure - High liquid temperature 	<ul style="list-style-type: none"> - Increase the inlet pressure - Reduce the liquid temperature - Reduce the pressure drop before the pump
Leaking shaft seal	<ul style="list-style-type: none"> - Dry run - Incorrect rubber grade - Abrasive particles in the liquid 	Replace: All wearing parts If necessary: <ul style="list-style-type: none"> - Change rubber grade - Select stationary and rotating seal ring in Silicon Carbide/Silicon Carbide
Leaking O-ring seals	Incorrect rubber grade	Change rubber grade



4 Operation

The pump is designed for cleaning in place (CIP). CIP = Cleaning In Place.
Study the instructions carefully and pay special attention to the warnings!
NaOH = Caustic Soda.
HNO₃ = Nitric acid.

4.3 Recommended cleaning

Step 1



Always handle lye and acid with great care.

Caustic danger!



Always use rubber gloves!



Always use protective goggles!

Step 2



Never touch the pump or the pipelines when sterilizing.

Danger of burns!

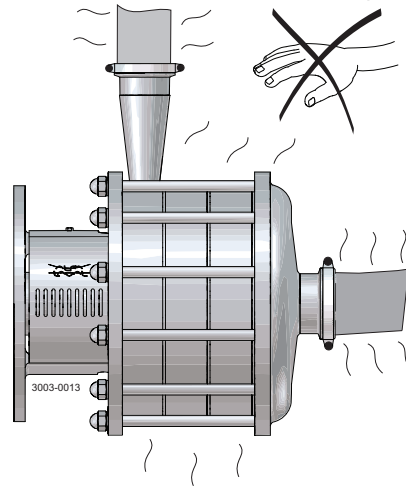

Step 3

Examples of cleaning agents: Use clean water, free from chlorides.

1. 1% by weight NaOH at 70°C (158°F).

1 kg (2.2 lb) NaOH + 100 l (26.4 gal) water = Cleaning agent.

2.2 l (0.6 gal) 33% NaOH + 100 l (26.4 gal) water = Cleaning agent.

2. 0.5% by weight HNO₃ at 70°C (158°F).

0.7 l (0.2 gal) 53% HNO₃ + 100 l (26.4 gal) water = Cleaning agent.

1. Avoid excessive concentration of the cleaning agent
⇒ Dose gradually!
2. Adjust the cleaning flow to the process.
Sterilization of milk/viscous liquids
⇒ Increase the cleaning flow!

Step 4



Always rinse well with clean water after using a cleaning agent.

NOTE

The cleaning agents must be stored/disposed of in accordance with current regulations/directives.

Always rinse!

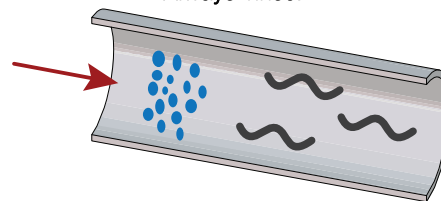

Water Cleaning agent



CSI

CONTACT CSI FOR MORE INFORMATION | CSIDESIGNS.COM | SALES@CSIDESIGNS.COM | 417.831.1411

Maintain the pump carefully. Study the instructions carefully and pay special attention to the warnings!
Always keep spare shaft seals and rubber seals in stock.
See separate motor instructions.

5.1 General maintenance

Step 1



Always read the technical data thoroughly. (See technical data on page 32)



Always disconnect the power supply when servicing the pump.

NOTE

All scrap must be stored/discharged in accordance with current rules/directives.

Step 2



Never service the pump when it is hot.



Never service the pump with pump and pipelines under pressure.

Atmospheric pressure required!

Danger of burns!

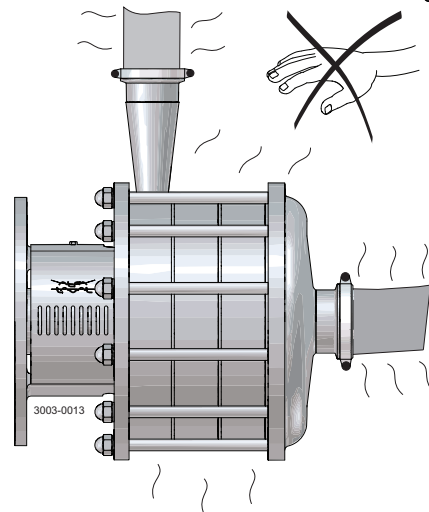

Step 3

Recommended spare parts:

Order Service Kits from Service kits list (see page 7 Parts list and service kits).

Ordering spare parts

Contact your local Alfa Laval sales company.



CSI

CONTACT CSI FOR MORE INFORMATION | CSIDESIGNS.COM | SALES@CSIDESIGNS.COM | 417.831.1411

5 Maintenance

Maintain the pump carefully. Study the instructions carefully and pay special attention to the warnings!
 Always keep spare shaft seals and rubber seals in stock.
 See separate motor instructions.

	Shaft seal	Rubber seals	Motor bearings
Preventive maintenance	Replace after 12 months: (one-shift) - Stationary and rotating seal ring - Quad-/O-rings	Replace when replacing the shaft seal	
Maintenance after leakage (leakage normally starts slowly)	Replace at the end of the day: - Stationary and rotating seal ring - Quad-/O-rings	Replace when replacing the shaft seal	
Planned maintenance	<ul style="list-style-type: none"> - Regular inspection for leakage and smooth operation - Keep a record of the pump - Use the statistics for planning of inspections Replace after leakage: - Stationary and rotating seal ring - Quad-/O-rings	Replace when replacing the shaft seal	Yearly inspection is recommended - Replace complete bearing if worn - Ensure that the bearing is axially locked (See motor instructions)
Lubrication	Before fitting Lubricate the O-rings with silicone grease or silicone oil	Before fitting Silicone grease or silicone oil	See "Relubrication Intervals", section 6.2 Relubrication intervals on page 33

5.2 Cleaning Procedure

Cleaning Procedure for Soiled Impeller Screw Tapped Hole:

1. Remove stub shaft (7) per section 4 of Service manual.
2. Submerge and soak Stub Shaft for 5 minutes in COP tank with 2% caustic wash
3. Scrub the blind tapped impeller screw hole vigorously by plunging a clean 1/2" diameter sanitary bristle pipe brush in and out of the hole for two minutes while submerged.
4. Soak Stub Shaft (7) in acid sanitizer for 5 minutes, then scrub blind tapped hole as described in step 3 above.
5. Rinse well with clean water and blow-dry blind tapped hole with clean air.
6. Swab test the inside of the tapped hole to determine cleanliness.
7. Should the swab test fail, repeat steps 2 thru 6 above until swab test is passed.

Should swab testing continue to fail, or time is of the essence, install a new (spare) Stub Shaft (7).



CSI

CONTACT CSI FOR MORE INFORMATION | CSIDESIGNS.COM | SALES@CSIDESIGNS.COM | 417.831.1411

Study the instructions carefully. The items refer to the parts list and service kits section.

Handle scrap correctly.

* : Relates to the shaft seal.

5.3 Dismantling of pump/shaft seals

Step 1

Remove the cap nuts (29), washer (30), pump cover (49) and O-ring (32).

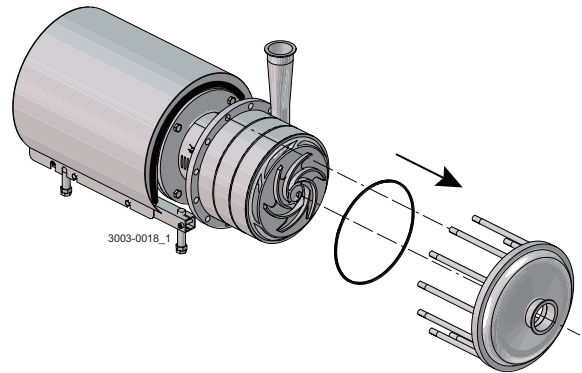

Step 2

Flushed shaft seal:

Unscrew tubes (25) using a spanner..

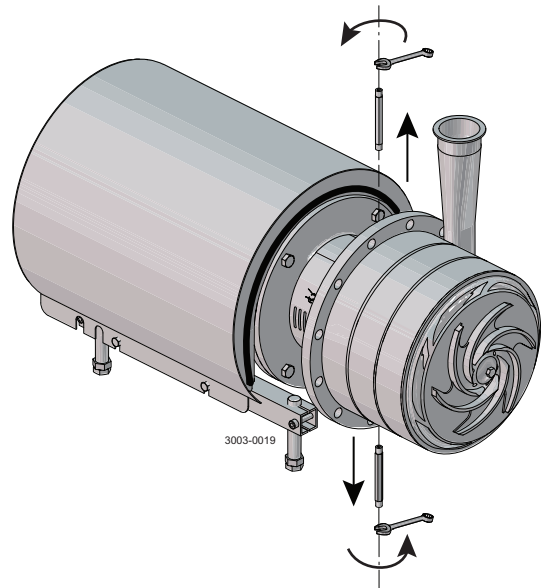

Step 3

Remove screw (16) and adaptor guard (17).

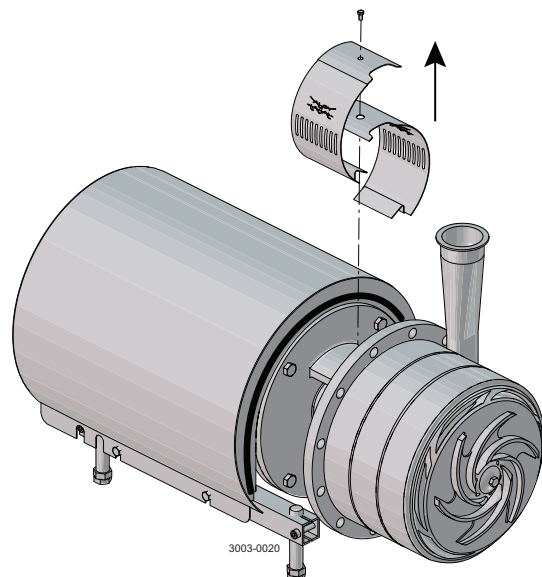

5 Maintenance

Study the instructions carefully. The items refer to the parts list and service kits section.

Handle scrap correctly.

* : Relates to the shaft seal.

Step 4

Remove impeller screw (47) O-ring (41) and impeller (45).

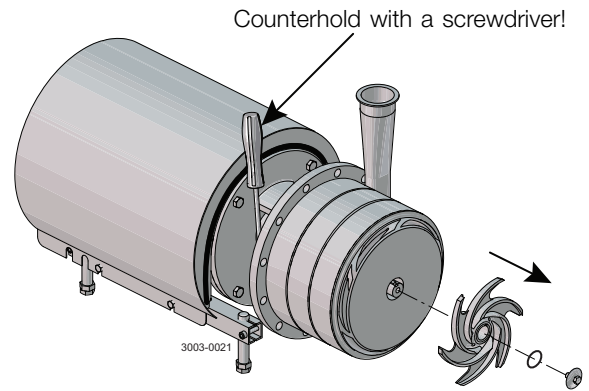

Step 5

1. Remove intermediate casing (46) (3 or 4 stage) and/or pump casing (42).
2. Remove impeller (45) and O-rings (41) in between the stages.

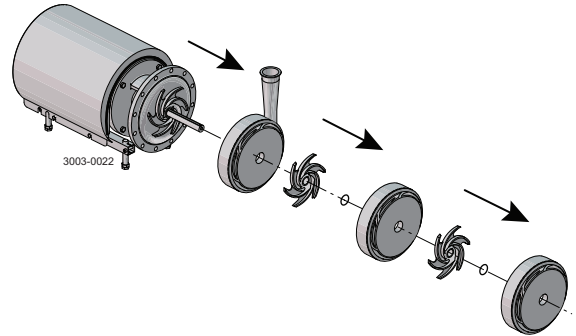

Step 6

Remove guide vanes (44) and O-ring (43) from intermediate casing (3 or 4 stage) and /or pump casing (42).

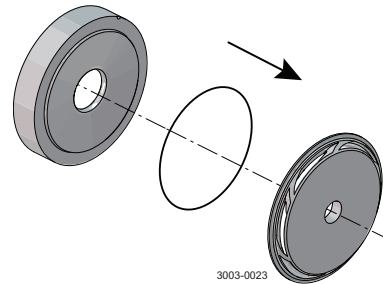

Step 7

Remove impeller (40) and the rotating part of the shaft seal, and remove O-ring (41) from impeller.

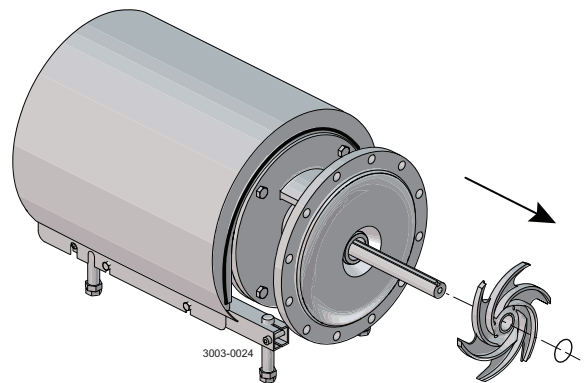

Study the instructions carefully. The items refer to the parts list and service kits section.

Handle scrap correctly.

* : Relates to the shaft seal.

Step 8

Remove space ring (35) and the rotating part of the seal from the impeller.

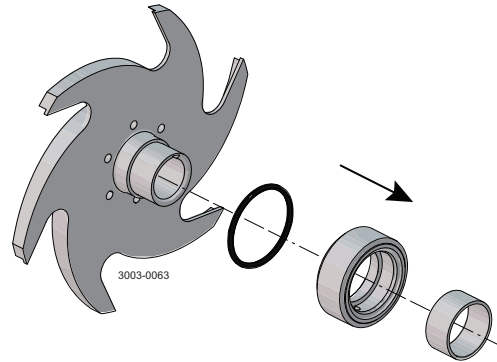

Step 9

Remove rotating seal ring (36) the quad rings/O-rings (37, 39) and the supporting (38a) from rotating seal housing (38).

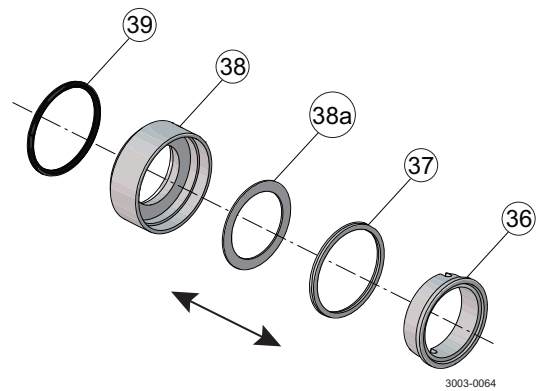

Step 10

1. Remove the nuts (20), the washers (21) and back plate (31).
2. Remove O-ring (32) from the back plate.

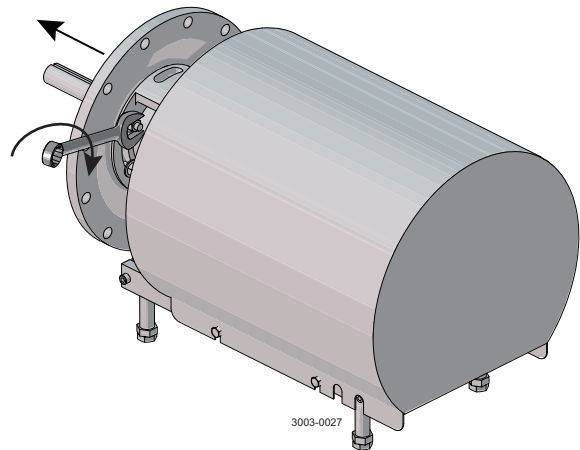

Step 11

1. Remove stationary seal ring (34).
2. Remove O-ring (33) from the stationary seal ring.

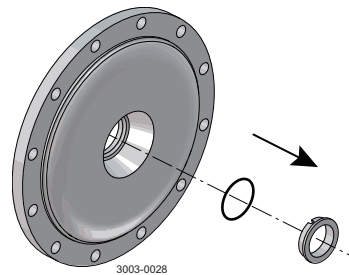

5 Maintenance

Study the instructions carefully. The items refer to the parts list and service kits section.
Handle scrap correctly.

* : Relates to the shaft seal.

Step 12

Flushed shaft seal:

1. Remove the screws (24) and seal housing (26).
2. Remove lip seal (28) and O-ring (27) from the seal housing.
3. Remove seal ring (23) from stub shaft (11).
4. Remove O-ring (22) from the seal ring.

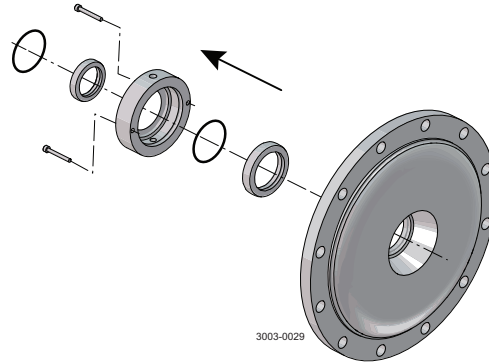

Step 13

1. Remove scroud (2).
2. Remove nuts (7), washers (8), screws (19) and adaptor (18).

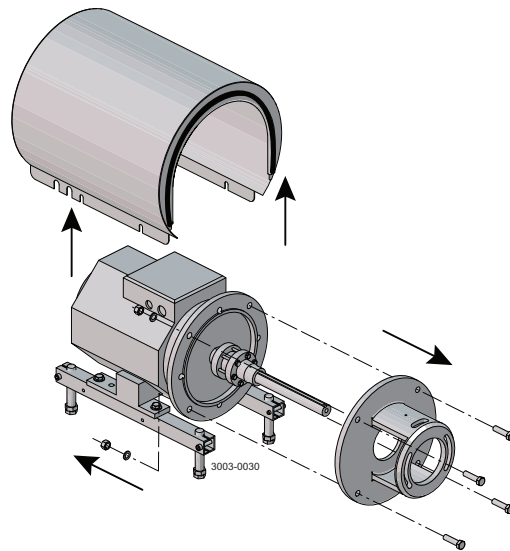

Step 14

1. Loosen the screws (15).
2. Remove stub shaft (11) and the compression rings (9,13).

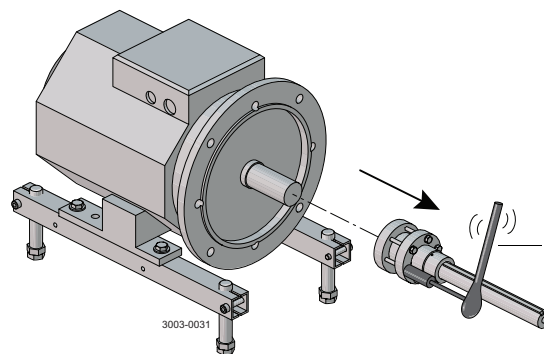

Step 15

Remove the screws (15), washers (15a) and the compression rings (9,13).

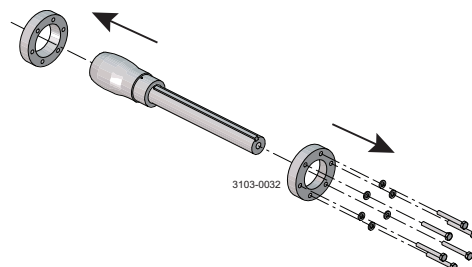

Study the instructions carefully. The items refer to the parts list and service kits section.
 Handle scrap correctly.
 * : Relates to the shaft seal.

5.4 Assembly of Pump/Assembly of Shaft Seal - LKH-110

Step 1

1. Fit the compression rings (9,13), washers (15a) and the screws (15) on stub shaft (11).
2. Fit the stub shaft on the motor shaft.
3. Check the clearance between the end of the stub shaft and the motor flange.

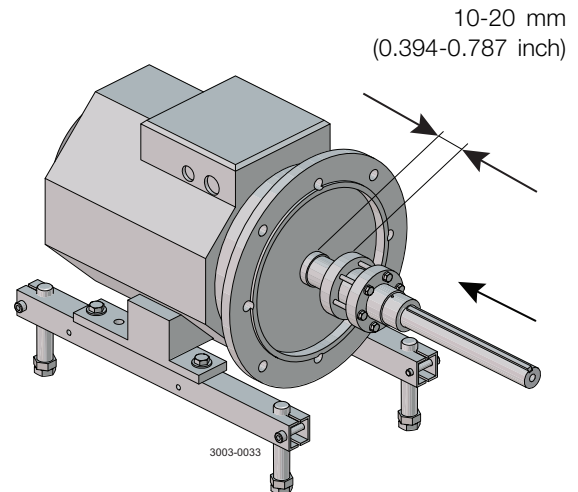

Step 2

1. Tighten the screws (15) evenly.
2. Ensure that stub shaft (11) can be moved on the motor shaft.

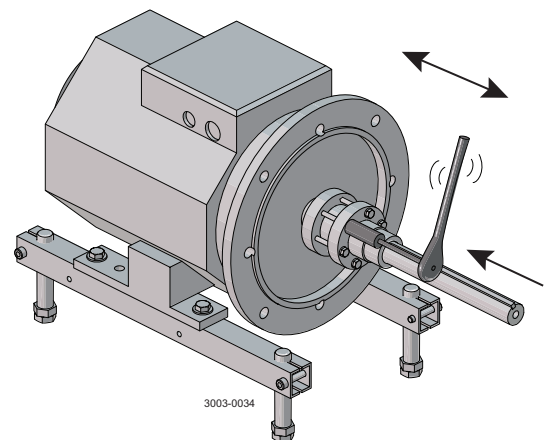

Step 3

Fit adaptor (18), screws (19), washers (8) and nuts (7).

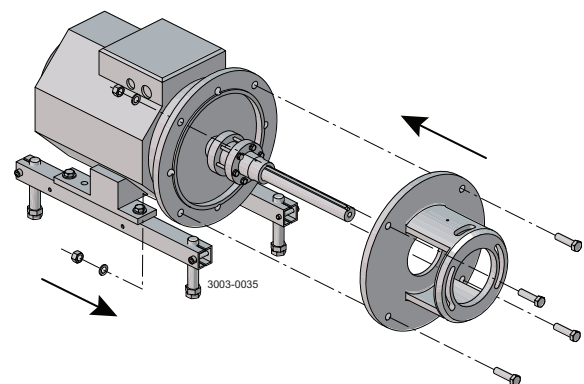

5 Maintenance

Study the instructions carefully. The items refer to the parts list and service kits section.

Handle scrap correctly.

* : Relates to the shaft seal.

Step 4

Fit back plate (31), washers (21) and nuts (20).

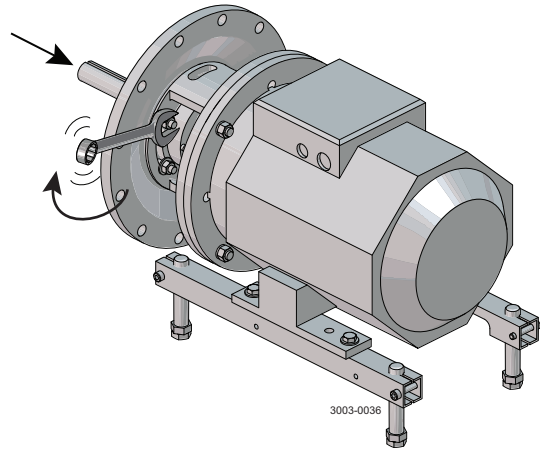

Step 5

1. Assemble the rotating part of the shaft seal.
2. Fit the seal part and the space ring on impeller (40).

CAUTION!

Ensure that the driver in the rotating seal housing enters the notch in the rotating seal ring.

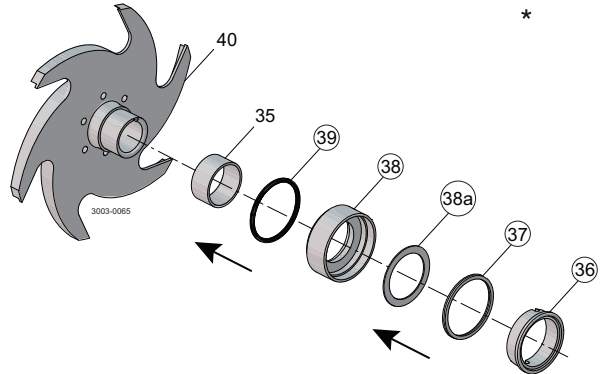

Step 6

1. Fit impeller (40,45) on stub shaft (11). Fit and tighten impeller screw (47).
2. Ensure that the clearance between impeller (40) and back plate (31) is 1mm (0.0394 inch).

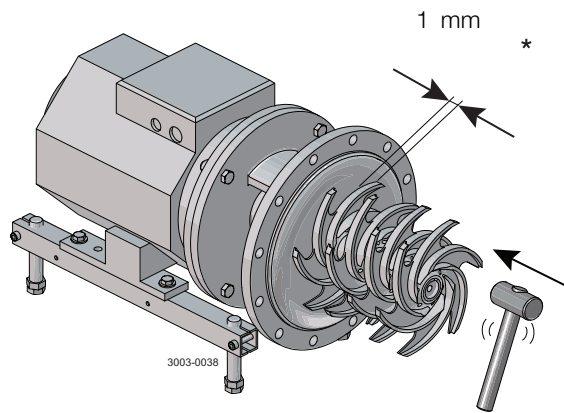

Study the instructions carefully. The items refer to the parts list and service kits section.

Handle scrap correctly.

* : Relates to the shaft seal.

Step 7

1. Remove impeller screw (47) and remove impeller (40,45) and back plate (31).
2. Tighten the screws (15) evenly to 15Nm. (11 lbf-ft)

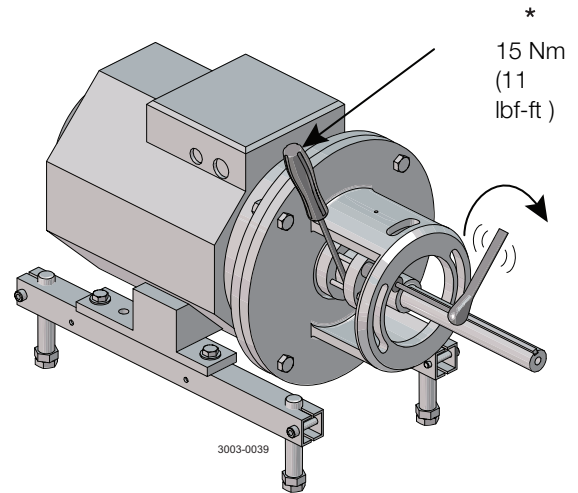

Step 8

1. Fit O-ring (33) on stationary seal ring (34).
2. Press the stationary seal ring in back plate (31).

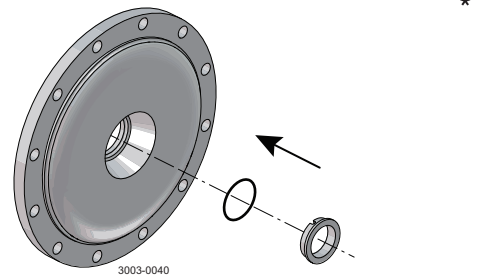

Step 9

Flushed shaft seal:

1. Fit lip seal (28) in seal housing (26).
2. Fit O-ring (27) in the seal housing.
3. Fit the housing on back plate (31) and tighten the screws (24).

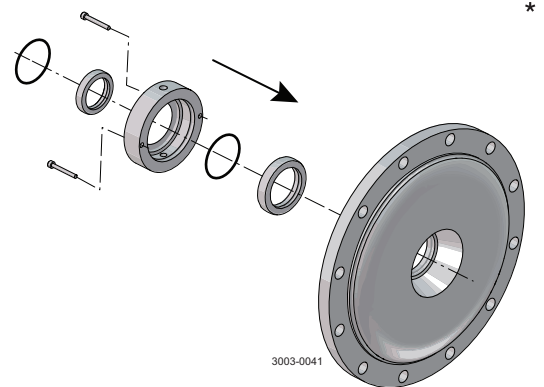

Step 10

1. Fit back plate (31), washers (21) and nuts (20).
2. Fit O-ring (41) in impeller. Fit impeller (40) with shaft seal parts and space ring on shaft (11).
3. Fit O-ring (32) on the back plate.

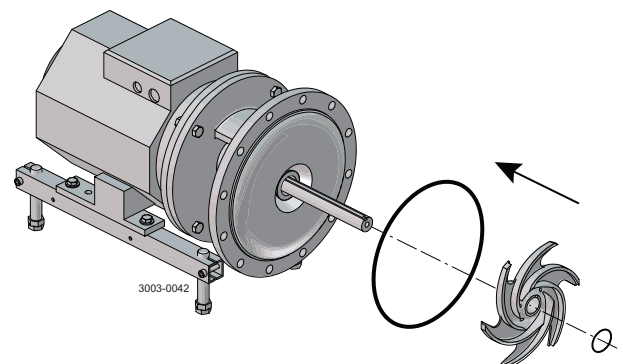

5 Maintenance

Study the instructions carefully. The items refer to the parts list and service kits section.

Handle scrap correctly.

* : Relates to the shaft seal.

Step 11

LKH-112:

1. Fit pump casing (42) on back plate (31).
2. Fit O-ring (43) on casing. Fit guide vanes (44).
3. Fit O-ring (32) on guide vanes (44).
4. Go to Step 14

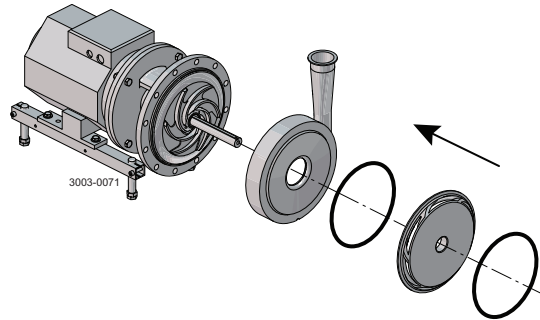

Step 12

LKH-113:

1. Fit O-ring (41) in impeller (45). Fit impeller (45) on shaft (11).
2. Fit intermediate casing (46).
3. Fit O-ring (43) on intermediate casing (46). Fit guide vane (44).
4. Fit O-ring (32) on guide vanes (44).
5. Go to Step 14

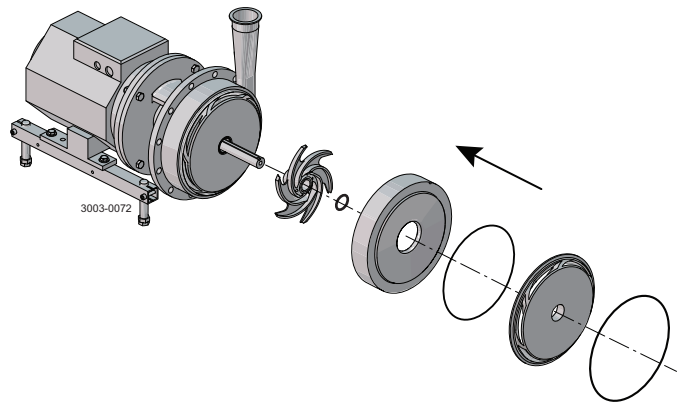

Step 13

LKH-114:

1. Fit O-ring (41) in impeller (45). Fit impeller (45) on shaft (11).
2. Fit intermediate casing (46).
3. Fit O-ring (43) on intermediate casing (46). Fit guide vane (44).
4. Fit O-ring (32) on guide vanes (44).

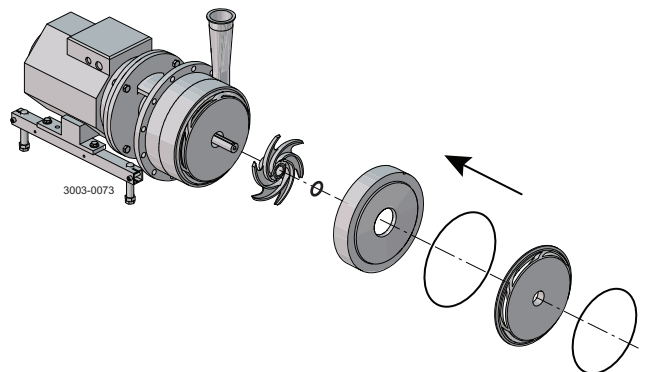

Step 14

1. Fit impeller (45) and O-ring (41) .
2. Fit and tighten impeller screw (47).

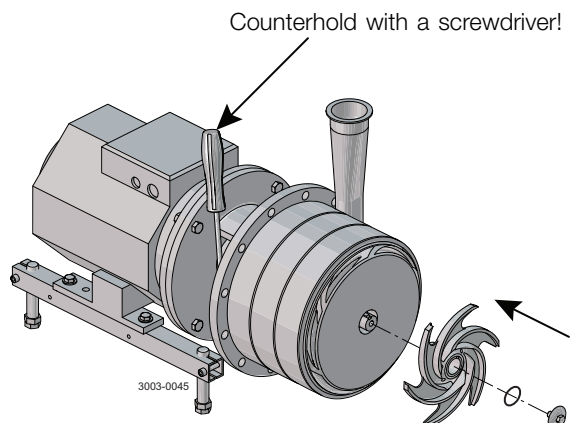

CSI

CONTACT CSI FOR MORE INFORMATION | CSIDESIGNS.COM | SALES@CSIDESIGNS.COM | 417.831.1411

5 Maintenance

Study the instructions carefully. The items refer to the parts list and service kits section.

Handle scrap correctly.

* : Relates to the shaft seal.

Step 15

1. Fit O-ring (32) and pump cover (49).
2. Fit washers (30) and cap nuts (29).
3. Tighten four cap nuts in following order. First 12 o'clock then 3, 9 o'clock and finally 6 o'clock. The rest to follow in random order. Torque values from Technical data section 6.3 are to be used.
4. **NOTE!** Tighten impeller screw with a socket wrench through the inlet.
5. **NOTE!** Rotate the pump shaft by hand and insure the impellers runs smoothly without touching.

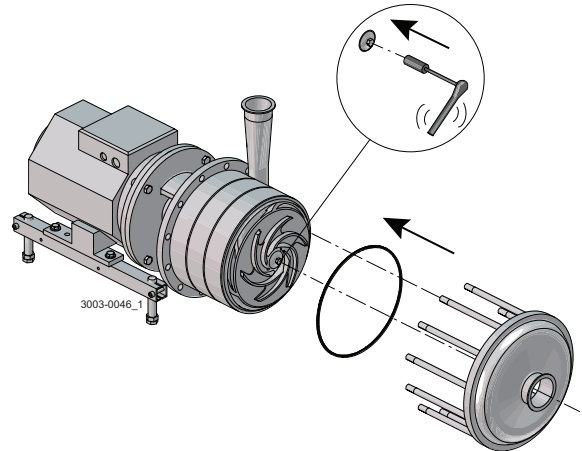

Step 16

1. Fit shroud (2).
 2. Fit safety guard (17) and screw (16).
- If pump is not supplied with flush connections the holes in the adaptor shall be covered by the guard.

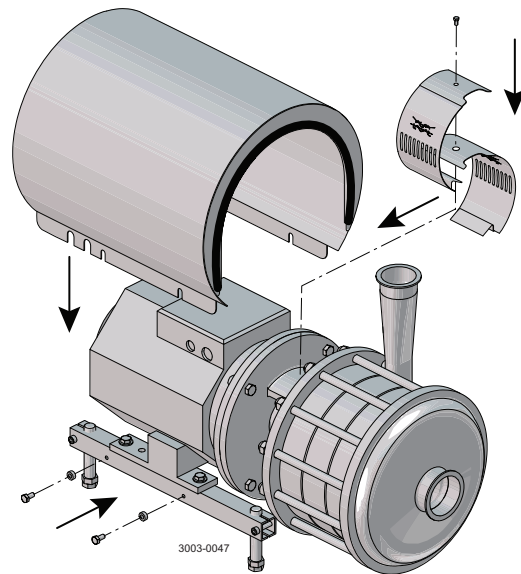

5 Maintenance

Study the instructions carefully. The items refer to the parts list and service kits section.

Handle scrap correctly.

* : Relates to the shaft seal.

Step 17

Flushed shaft seal:

Fit the tubes (25) on seal housing (26).

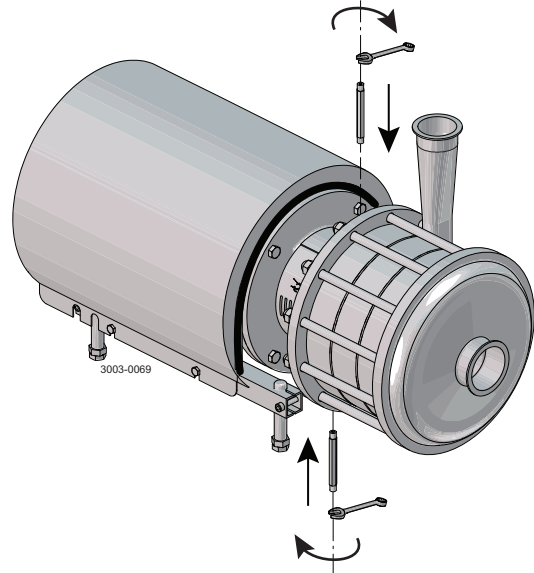

CSI

CONTACT CSI FOR MORE INFORMATION | CSIDESIGNS.COM | SALES@CSIDESIGNS.COM | 417.831.1411

Study the instructions carefully. The items refer to the parts list and service kits section.
Lubricate the rubber seals before fitting them.
* : Relates to the shaft seal.

5.5 Assembly of Pump/Assembly of Shaft Seal - LKH-120/P

Step 1

1. Fit the compression rings (9,13) and the screws (15) on stub shaft (11).
2. Fit the stub shaft on the motor shaft.
3. Check the clearance between the end of the stub shaft and the motor flange.

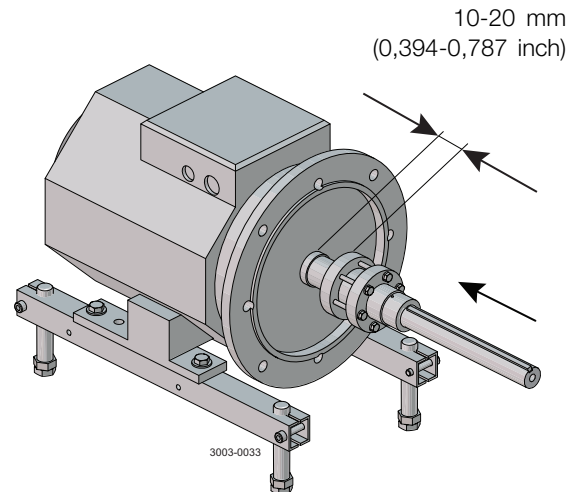

Step 2

1. Tighten the screws (15) evenly.
2. Ensure that stub shaft (11) can be moved on the motor shaft.

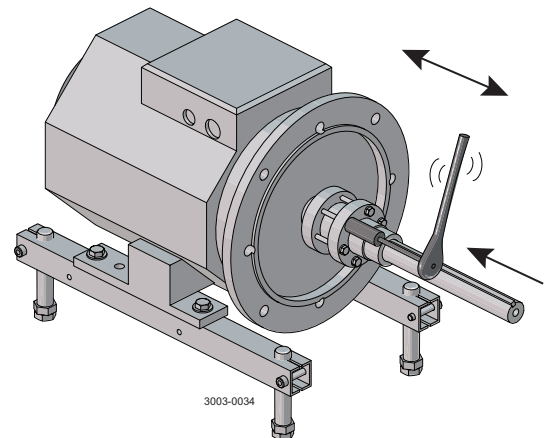

Step 3

Fit adaptor (18), screws (19), washers (8) and nuts (7).

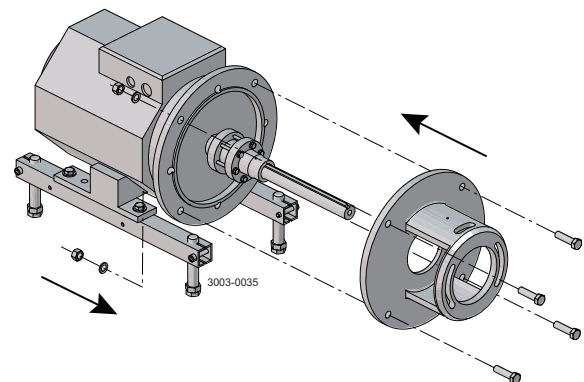

5 Maintenance

Study the instructions carefully. The items refer to the parts list and service kits section.

Lubricate the rubber seals before fitting them.

* : Relates to the shaft seal.

Step 4

1. Fit O-ring (37) on stationary seal ring (34).
2. Press the stationary seal ring in back plate (31).

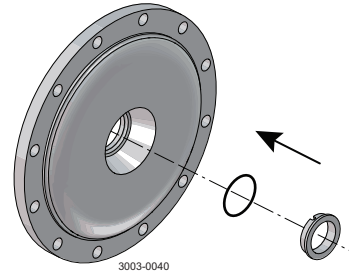

Step 5

Flushed shaft seal:

1. Fit lip seal (28) in seal housing (26).
2. Fit O-ring (27) in the seal housing.
3. Fit the housing on back plate (31) and tighten the screws (24).
4. Fit seal ring (23) with O-ring (22) on stub shaft (11).

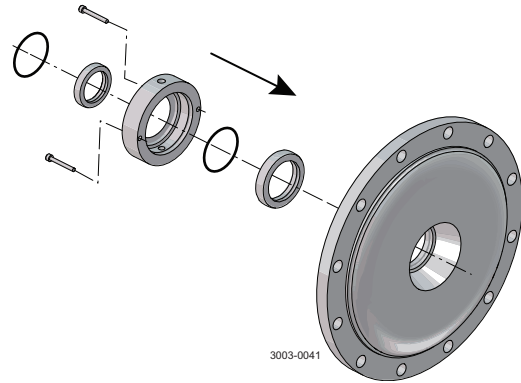

Step 6

Fit back plate (31), washers (21) and nuts (20).

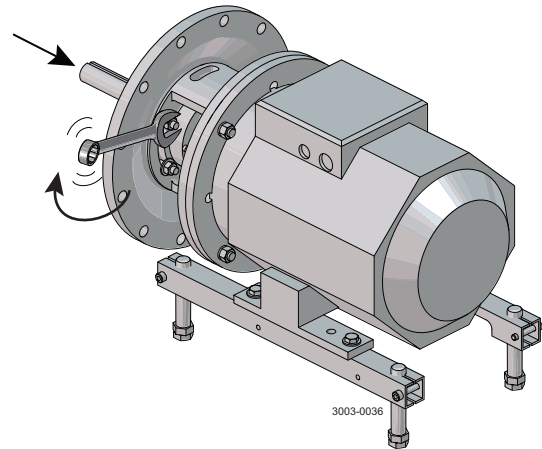

Step 7

1. Assemble the rotating part of the shaft seal.
2. Fit the seal part and the space ring on impeller (40).

CAUTION!

Ensure that the driver in the rotating seal housing enters the notch in the rotating seal ring.

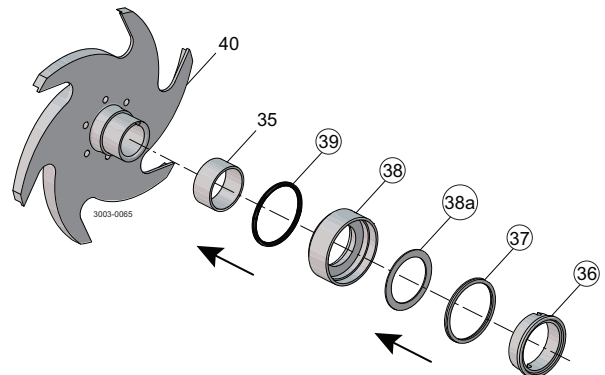

Study the instructions carefully. The items refer to the parts list and service kits section.

Lubricate the rubber seals before fitting them.

* : Relates to the shaft seal.

Step 8

1. Fit back plate (31), washers (21) and nuts (20).
2. Fit O-ring (41) in impeller. Fit impeller (40) with shaft seal parts and space ring on shaft (11).
3. Fit O-ring (32) on the back plate.

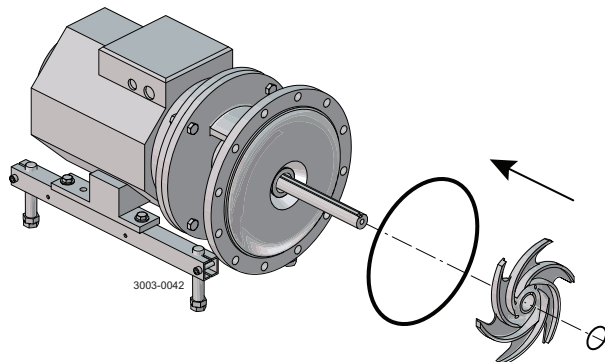

Step 9

LKH-122/P:

1. Fit pump casing (42) on back plate (31).
2. Fit O-ring (43) on casing. Fit guide vanes (44).
3. Fit O-ring (32) on guide vanes (44).
4. Go to Step 12

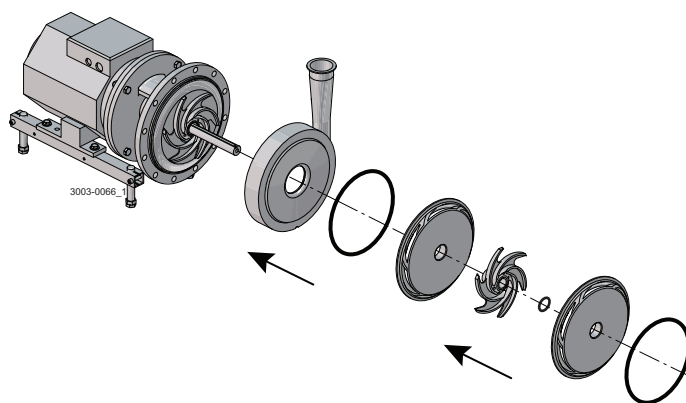

Step 10

LKH-123/P:

1. Fit O-ring (41) in impeller (45). Fit impeller (45) on shaft (11).
2. Fit intermediate casing (46).
3. Fit O-ring (43) on intermediate casing (46). Fit guide vane (44).
4. Fit O-ring (32) on guide vanes (44).
5. Go to Step 12

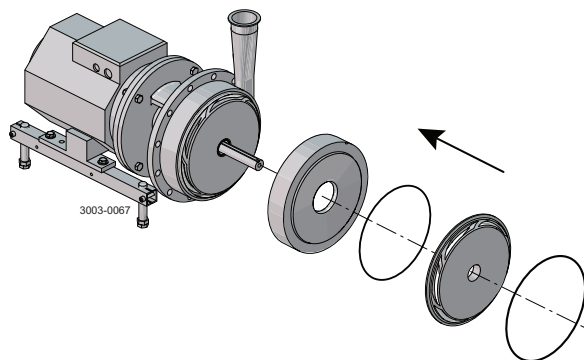

Step 11

LKH-124/P:

1. Fit O-ring (41) in impeller (45). Fit impeller (45) on shaft (11).
2. Fit intermediate casing (46).
3. Fit O-ring (43) on intermediate casing (46). Fit guide vane (44).
4. Fit O-ring (32) on guide vanes (44).

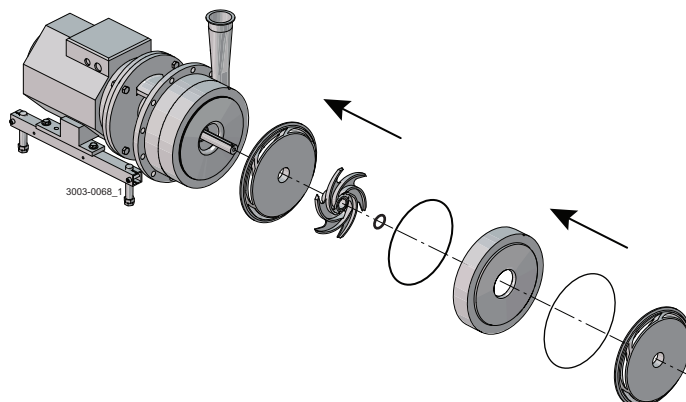

5 Maintenance

Study the instructions carefully. The items refer to the parts list and service kits section.
Lubricate the rubber seals before fitting them.

* : Relates to the shaft seal.

Step 12

1. Fit impeller (45) and O-ring (41).
2. Fit and tighten impeller screw lightly (47).

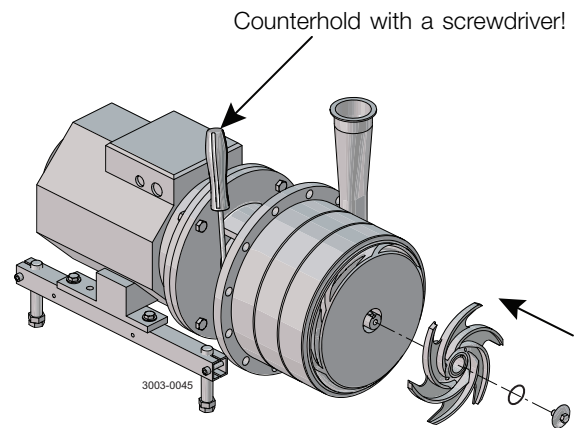

Step 13

1. Fit O-ring (32) and pump cover (49).
2. Fit the washers (30) and the cap nuts (29).
3. Tighten four cap nuts in following order. First 12 o'clock then 3, 9 o'clock and finally 6 o'clock. The rest to follow in random order. Torque values from Technical data section 6.3 are to be used.
4. **NOTE!** Tighten impeller screw (47) with a socket wrench through the inlet.

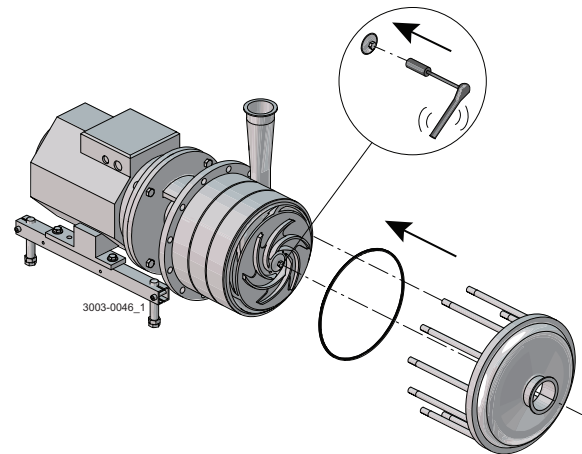

Step 14

1. Push the shaft completely forward until the impeller touches the cover and zero set the dial gauge.
2. Push back the shaft 0.6 mm (0.0236 inch).
3. Tighten the screws in the compression coupling with 18 Nm (13.3 lbf-ft).
4. **NOTE!** Rotate the pump shaft by hand and insure the impellers runs smoothly without touching.

Note: Special tool for dial gauge is optional (9612927801)

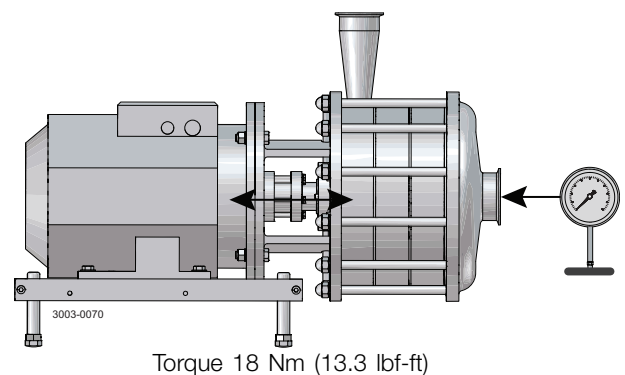

Study the instructions carefully. The items refer to the parts list and service kits section.
Lubricate the rubber seals before fitting them.

* : Relates to the shaft seal.

Step 15

1. Fit shroud (2).
2. Fit safety guard (17) and screw (16).

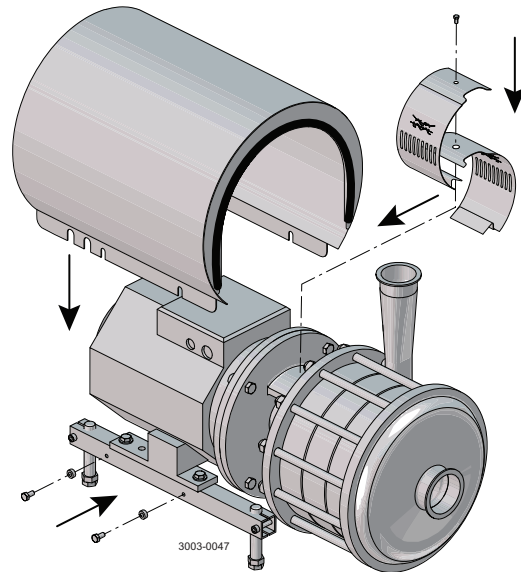

Step 16

Flushed shaft seal:

Fit the tubes (25) on seal housing (26).

If pump is not supplied with flush connections the holes in the adaptor shall be covered by the guard.

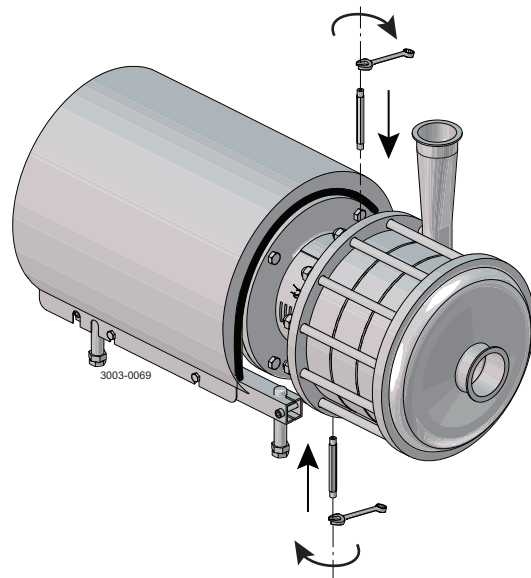

6 Technical data

It is important to observe the technical data during installation, operation and maintenance.
Inform possible personnel about the technical data.

6.1 Technical data

The LKH-110 and -120P pump is highly efficient and economical centrifugal pump, which meets the requirements of sanitary and gently product treatment and chemical resistance. LKH-110 and the LKH-120P is available in the following sizes, LKH-112, -113, -114 and LKH122/P, -123/P, -124/P. The instruction manual is part of the delivery. Study the instructions carefully. The large pump sizes are very heavy. Alfa Laval therefore recommends the use of a lifting crane when handling the pump.

Data						
Speed	Max. inlet pressure:				Motor	Backplate
	Max 50Hz		Max 60Hz			
Shaft seal material	C/SiC	SiC/SiC	C/SiC	SiC/SiC		
Pump size						
LKH-112	10	10	10	10	Std	Std
LKH-113	10	10	10	10	Std	Std
LKH-114	10	10	10	10	Std	Std
LKH-112/P	N/A	30	N/A	30	Special	Reinforced
LKH-113/P	N /A	30	N/A	30	Special	Reinforced
LKH-114/P	N/A	25	N/A	25	Special	Reinforced
LKH-122/P	10	30	N/A	30	Special	Std
LKH-123/P	10	30	N/A	30	Special	Std
LKH-124/P	N/A	25	N/A	20	Special	Std

Data			
Temperature range	-10°C to +140°C	(EPDM)	(14°F to 284°F)
Noise level	60-80 dB(A)		
Max. speed	3600 rpm		
Materials			
Product wetted steel parts	AISI 316L and Duplex steel		
Other steel parts	Stainless steel		
Product wetted seals	EPDM (standard)		
Other O-rings	EPDM		
Alternative seals	Nitrile (NBR), Fluorinated rubber (FPM)		
Finish	Standard Blasted		
Shaft seal			
Seal types	Single internal or flushed seal		
Max. temperature flush media	70°C		
Max. water pressure (flushed seal)	Normal atmosphere	(max. 1bar)	(14.5 psi)
Water consumption (flushed seal)	0.25 - 0.5 l/min.	(0.07-0.13 gal/min)	
Material, stationary seal ring	Silicon carbide		
Material, rotating seal ring	Carbon or silicon carbide		
Material, Quad-/O-rings	EPDM (standard)		
Motor			
Foot-flanged motor acc. to IEC metric standard 2 poles = 3000/3600 rpm. at 50/60 Hz IP55 (drain hole with labyrinth plug), insulation class F			
Motor types:	<ul style="list-style-type: none"> - Standard motor with a fixed ball bearing on drive side - Special motor with fixed special bearings 		
NOTE: Special motor must be ordered if required.			



CSI

CONTACT CSI FOR MORE INFORMATION | CSIDESIGNS.COM | SALES@CSIDESIGNS.COM | 417.831.1411

Relubrication interval 50 Hz (3000 rpm)/Relubrication interval 60 Hz (3600 rpm). (Vendor) quantity in Drive End/quantity in Non Drive End.

6.2 Relubrication intervals

The table is for 100°C internal bearing temperature. an increase in temperature of 15°C (ambient or internal in bearings), will reduce the greasing interval and bearing lifetime by 50%. Lubrication interval for vertically mounted pumps is half the value stated in the table.

ABB IEC motors

Frame size	Motor power (kW)	LKH-5 - 90 LKHI-10 - 60* LKH-110* LKHSP LKH Ultra Pure LKHex 50/60 Hz	LKHPF-10 - 60 LKHI-10 - 60 LKH-110 50/60 Hz	LKH-85 50/60 Hz	LKH-122/P LKH-123/P LKH-124/P LKHPF-70 50/60 Hz
80	0.75	Permanently lubricated			
80	1.1	Permanently lubricated			
90	1.5	Permanently lubricated	Permanently lubricated		
90	2.2	Permanently lubricated	Permanently lubricated		
100	3.0	Permanently lubricated			
112	4.0	Permanently lubricated	4300h/3300h - DE/NDE:10g		
132	5.5	Permanently lubricated	3600h/3000h - DE/NDE:15g		
132	7.5	Permanently lubricated	3600h/3000h - DE/NDE:15g		
160	11	Permanently lubricated	3100h/2300h - DE/NDE:25g		
160	15	Permanently lubricated	3100h/2300h - DE/NDE:25g		
160	18.5	Permanently lubricated	3100h/2300h - DE/NDE:25g		
180	22	Permanently lubricated	2600h/2000h - DE/NDE:30g		8000h/6000h - DE/NDE:42g
200	30	Permanently lubricated		8000h/6000h - DE/NDE:40g	4500h/2000h - DE/NDE:55g
200	37	Permanently lubricated		8000h/6000h - DE/NDE:40g	5000h/2500h - DE/NDE:55g
200	45	Permanently lubricated		8000h/6000h - DE/NDE:40g	2500h/1000h - DE/NDE:55g
250	55	Permanently lubricated		8000h/3000h - DE/NDE:60g	2500h/1000h - DE/NDE:73g
250	75	Permanently lubricated		4000h/1500h - DE/NDE:60g	1500h/500h - DE/NDE:73g

* inlet pressure < 10 bar (145 psi)

Recommended grease types:

LKHPF-10/-70 – LKH-110 - LKH-120:

- Esso: Unirex N2 or N3 (Lithium complex base)
- Shell: Albida EMS 2 (Lithium complex base)
- FAG: Arcanol TEMP110 (Lithium complex base)
- Mobil: Mobilith SHC 100 (Lithium complex base)
- Klüber: Klüberplex BEM 41-132 (Special Lithium base)
- Lubcon: Turmogrease L 802 EP PLUS (Lithium complex base)
- Lubcon: Turmogrease PU703 (polyurea base)

LKH-85:

- Klüber: Klüberplex Quiet BQH 72-102 (polyurea base)

WARNING: Polyurea based grease must not be mixed with Lithium complex base grease and vice versa.



6 Technical data

Relubrication interval 50 Hz (3000 rpm)/Relubrication interval 60 Hz (3600 rpm). (Vendor) quantity in Drive End/quantity in Non Drive End.

Table 1. Sterling Nema motors

Motor RPM	Frame VS. HP	Type of service Standard 8 hrs/day	Heavy duty 24 hrs/day
3600	143T - 286TS 1.5 - 30	*	*
	324TS - 455TS 40 - 150	6 Months	2 Months
1800	143T - 256T 1 - 20	*	*
	284T - 326T 25 - 50	4 Months	18 Months
	364T - 445T 60 - 150	9 Months	3 Months
1200	143T - 256T 0.75 - 10	*	*
	284T - 326T 15 - 30	4 Years	18 Months
	364T - 445T 40 - 125	1 Year	4 Months

* Motor of this size normally do not have bearings that can be re-lubricated.
These bearings should be replaced at least every 5 years for 8 hr/day service, or every 2 years for 24 hr/day service.

Warning: Bearing grease is Klüber NBU-15 - DO NOT SUBSTITUTE!

6.3 Torque Specifications

Below table specifies the tightening torques for the screws, bolts and nuts in this pump.
Always use below torques if no other values are stated. This can be a matter of personal safety.

Size	Tightening torque	
	Nm	lbf-ft
M8	20	14.8
M10	40	29.5
M12	67	49.0
M14	110	81.0



6 Technical data

Relubrication interval 50 Hz (3000 rpm)/Relubrication interval 60 Hz (3600 rpm). (Vendor) quantity in Drive End/quantity in Non Drive End.

6.4 Weight (kg)

Pump Type: LKH-110

Size	90 1.5kW	100 3kW	112 4kW	132		160	160	160
				5.5kW	7.5kW	11kW	15kW	18.5kW
112	63	77	83	99	114	155	166	220
113		80	56	118	118	158	169	223
114				121	121	163	174	228

Weight can vary depending of configuration. Weight is only to be seen as a reference value during handling, transporting and packaging.

Pump Type: LKH-120

Size	180 22kW	30kW	200 37kW	45kW	250 55kW	75kW
122	247	330	370	374		
123	277	350	390	394	510	545
124		367	407	411	527	562

Weight can vary depending of configuration. Weight is only to be seen as a reference value during handling, transporting and packaging.



6 Technical data

Relubrication interval 50 Hz (3000 rpm)/Relubrication interval 60 Hz (3600 rpm). (Vendor) quantity in Drive End/quantity in Non Drive End.

6.5 Noise emission

Pump Type	Sound pressure level (dBA)
LKH-5	60
LKH-10	69
LKH-15	72
LKH-20	70
LKH-25	74
LKH-35	71
LKH-40	75
LKH-45	70
LKH-50	75
LKH-60	77
LKH-70	88
LKH-75	79
LKH-85	86
LKH-90	75
LKH-112	70
LKH-113	69
LKH-114	68
LKH-122	75
LKH-123	77
LKH-124	80
SolidC-1	68
SolidC-2	72
SolidC-3	73
SolidC-4	72
MR-166	76
MR-185	82
MR-200	81
MR-300	82
GM	54
FM-OS	61

The above LKH noise levels are the same for LKHFPF, LKHI, LKH UltraPure, LKH Evap, LKHHex.
The above SolidC noise levels are the same for SolidC UltraPure.

The noise measurements have been carried out with original motor and shroud, approximately at the Best Efficiency Point (BEP) with water at ambient temperature and at 50 Hz.

Very often the noise level generated by the flow through the process system (eg. valves, pipes, tanks etc.) is much higher than what is generated by the pump itself. Therefore it is important to consider the noise level from the total system and take the necessary precautions with regards to personal safety if required.



CSI

CONTACT CSI FOR MORE INFORMATION | CSIDESIGNS.COM | SALES@CSIDESIGNS.COM | 417.831.1411

7 Parts list and service kits

Relubrication interval 50 Hz (3000 rpm)/Relubrication interval 60 Hz (3600 rpm). (Vendor) quantity in Drive End/quantity in Non Drive End.

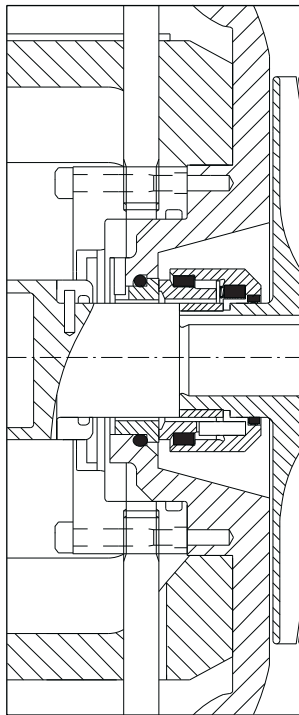
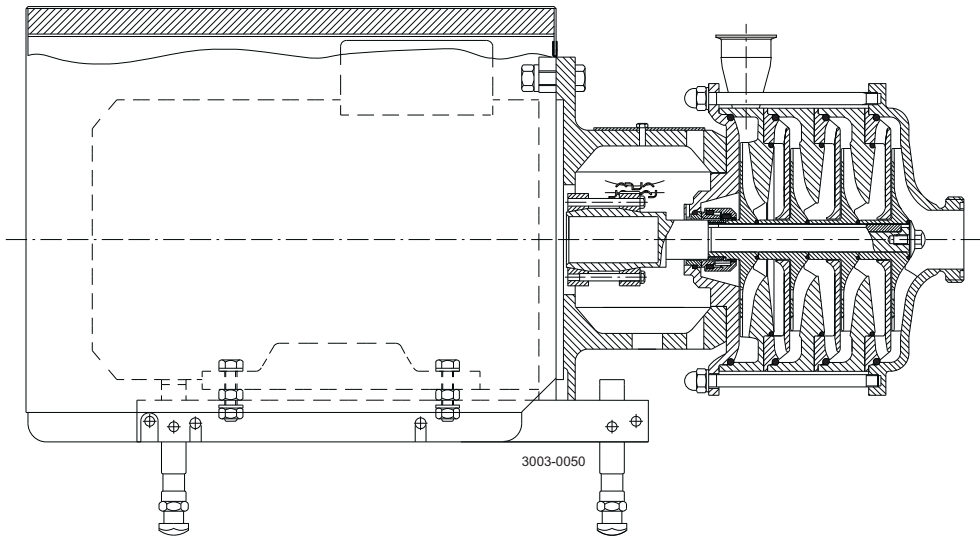

CSI

CONTACT CSI FOR MORE INFORMATION | CSIDESIGNS.COM | SALES@CSIDESIGNS.COM | 417.831.1411

7 Parts list and service kits

7.2 LKH Multi-Stage - Wet end

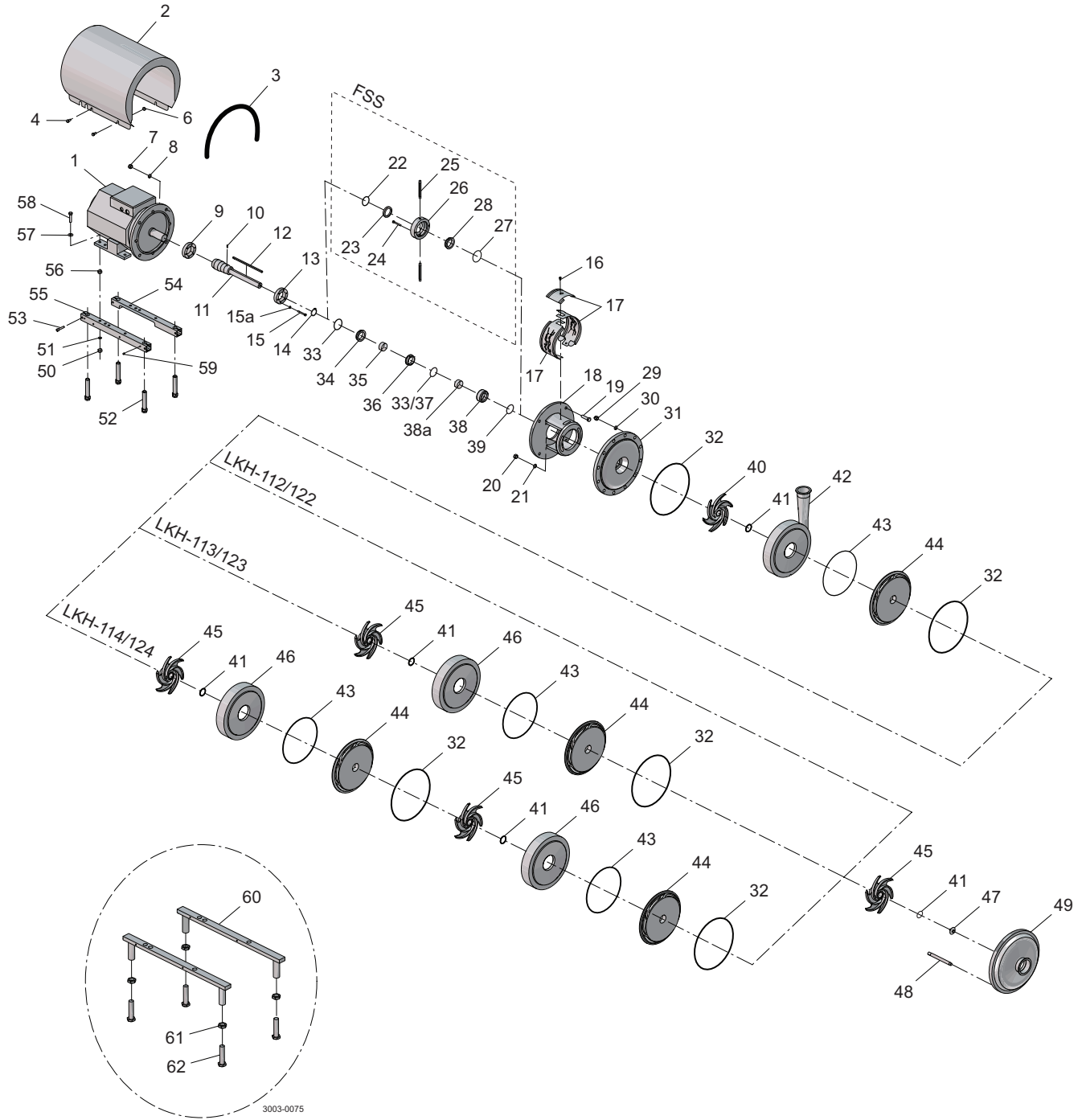

CSI

CONTACT CSI FOR MORE INFORMATION | CSIDESIGNS.COM | SALES@CSIDESIGNS.COM | 417.831.1411

7 Parts list and service kits

Parts list

Pos.	Qty	Denomination
12	1	Key
20	2	Nut
21	2	Washer
29	6	Cap nut
30	6	Washer
31	1	Back plate std. blasted
32	2	O-ring
40	1	Impeller back std. blasted
41	2	O-ring
42		Pump casing
43	1	O-ring
44	1	Guide vanes blasted
45	1	Impeller std. blasted
46	1	Intermediate casing blasted
47	1	Impeller screw std. Blasted
48	6	Bolt
49		Pump Cover
63	1	Set of 8 springs for rotating sealhousing

7 Parts list and service kits

7.3 LKH Multi-Stage - Motor dependent parts

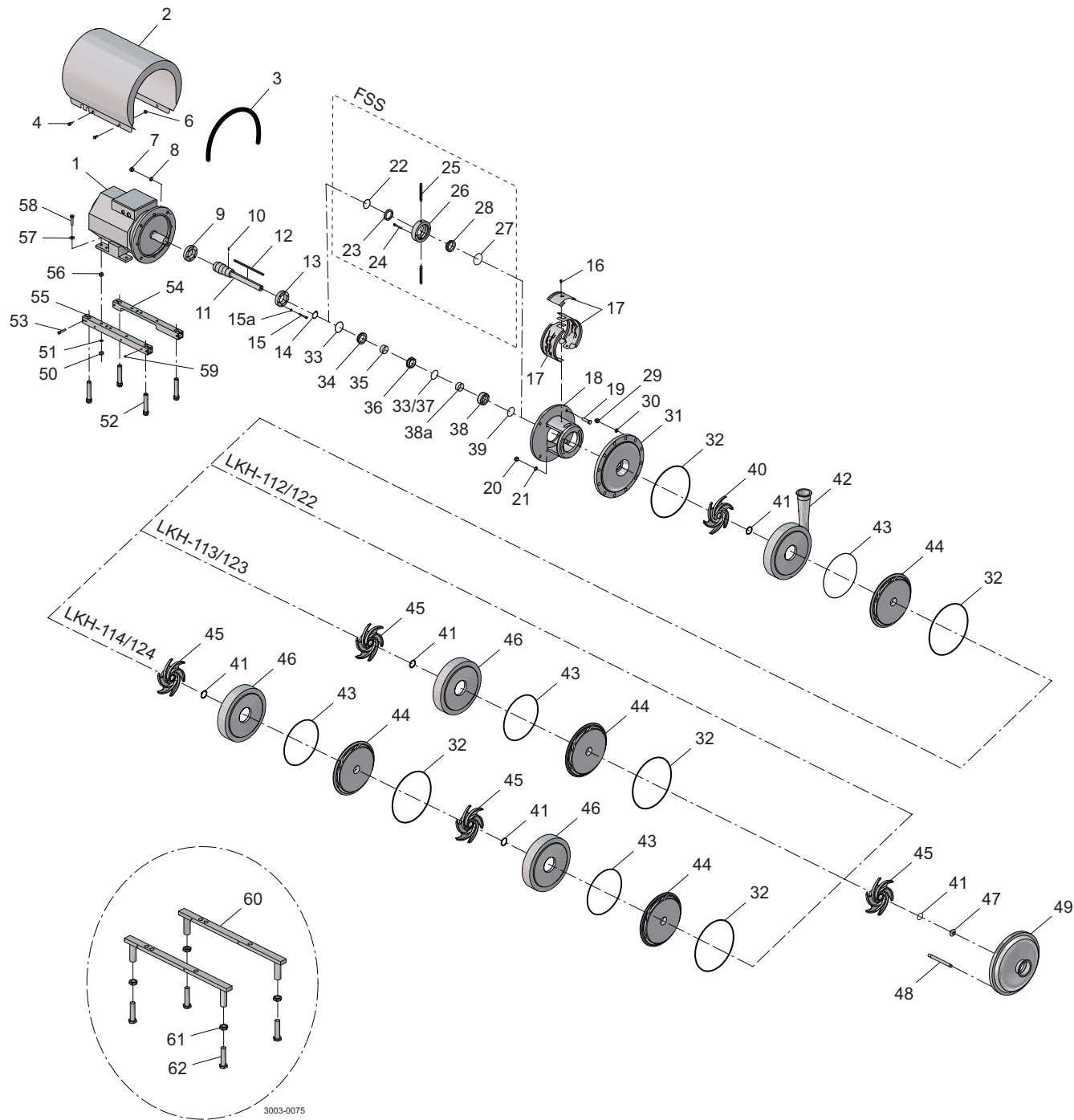

CSI

CONTACT CSI FOR MORE INFORMATION | CSIDESIGNS.COM | SALES@CSIDESIGNS.COM | 417.831.1411

7 Parts list and service kits

Parts list

Pos.	Qty	Denomination
1	1	Motor ABB 3000rpm
2	1	Shroud
3	1	Edge list
4	4	Screw
6	4	Distance sleeve
7	4	Nut for adaptor
8	1	Connex pin
9	1	Compression ring
10	1	Connex pin
11	1	Shaft
13	1	Compression ring
14	1	Retaining ring
15	6	Screw
15a	6	Washer
16	1	Screw
17	1	Safety guard set
18	1	Adaptor
19	4	Screw for adaptor
50	4	Nut
51	4	Spring washer
52	4	Leg
53	4	Screw
54	1	Support bar
55	1	Support bar
56	4	Nut
57	4	Washer
58	4	Screw
59	4	Pivot screw
60	2	Leg bracket
61	4	Nut for leg
62	4	Screw for leg

7 Parts list and service kits

7.4 LKH Multi-Stage - Shaft seal and Service kits

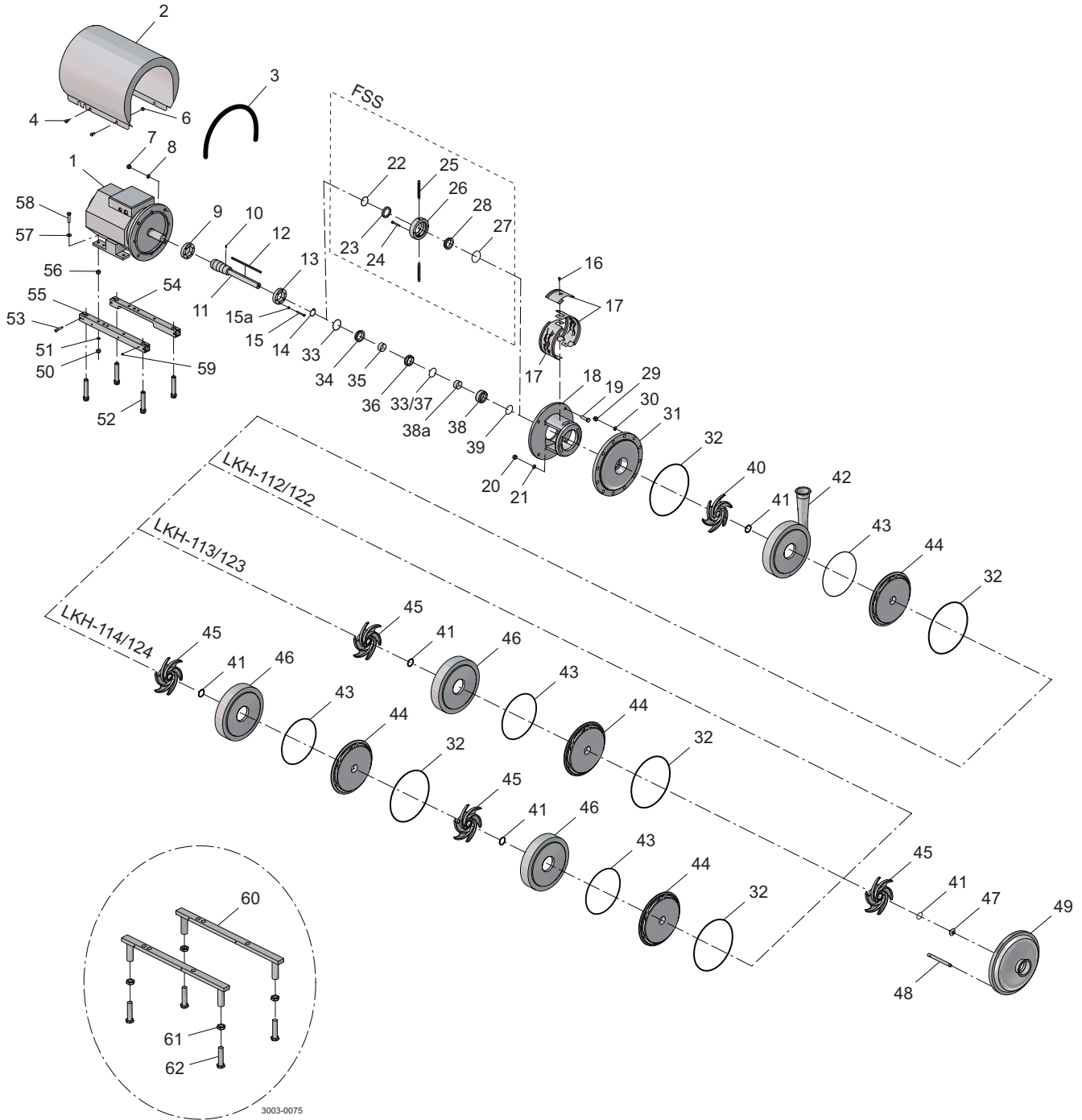

CSI

CONTACT CSI FOR MORE INFORMATION | CSIDESIGNS.COM | SALES@CSIDESIGNS.COM | 417.831.1411

Parts list

Pos.	Qty	Denomination
□○		Shaft seal complete
◆■		Shaft seal complete
22 ◆○	1	O-ring
23 ◆○	1	Sleeve
24	2	Screw
25	2	Tube
26	1	Seal housing
27 ◆○	1	O-ring
28 ◆○	1	Lip seal
33	1	O-ring
34	1	Stationary seal ring
35	1	Spacing ring
36	1	Rotating seal ring
37	1	Quad ring
38	1	Rotating seal housing
38a	1	Support ring
39	1	Quad ring

Service kits

Denomination	EPDM	NBR	FPM
Service kit for single shaft seal C/SIC			
□ Service kit C/SIC LKH-112/ LKH-112P	9611922096	9611922097	9611922098
Service kit C/SIC LKH-113/ LKH-113P	9611922102	9611922103	9611922104
Service kit C/SIC LKH-114/ LKH-114P	9611922108	9611922109	9611922110
Service kit C/SIC LKH-122	9611922409	9611922410	9611922411
Service kit C/SIC LKH-123	9611922934	9611922935	9611922936
Service kit C/SIC LKH-124	9611922679	9611922680	9611922681
Service kit for single shaft seal SIC/SIC			
■ Service kit SIC/SIC LKH-112/ LKH-112P	9611922655	9611922656	9611922657
Service kit SIC/SIC LKH-113/ LKH-113P	9611922661	9611922662	9611922663
Service kit SIC/SIC LKH-114/ LKH-114P	9611922667	9611922668	9611922669
Service kit SIC/SIC LKH-122	9611922673	9611922674	9611922675
Service kit SIC/SIC LKH-123	9611922679	9611922680	9611922681
Service kit SIC/SIC LKH-124	9611922685	9611922686	9611922687
Service kit for flushed shaft seal C/SIC			
○ Service kit C/SIC LKH-112/ LKH-112P	9611922099	9611922100	9611922101
Service kit C/SIC LKH-113/ LKH-113P	9611922105	9611922106	9611922107
Service kit C/SIC LKH-114/ LKH-114P	9611922111	9611922112	9611922113
Service kit C/SIC LKH-122	9611922412	9611922413	9611922414
Service kit C/SIC LKH-123	9611922937	9611922938	9611922939
Service kit C/SIC LKH-124	9611922943	9611922944	9611922945
Service kit for flushed shaft seal SIC/SIC			
◆ Service kit SIC/SIC LKH-112/ LKH-112P	9611922658	9611922659	9611922660
Service kit SIC/SIC LKH-113/ LKH-113P	9611922664	9611922665	9611922666
Service kit SIC/SIC LKH-114/ LKH-114P	9611922670	9611922671	9611922672
Service kit SIC/SIC LKH-122	9611922676	9611922677	9611922678
Service kit SIC/SIC LKH-123	9611922682	9611922683	9611922684
Service kit SIC/SIC LKH-124	9611922688	9611922689	9611922690



7 Parts list and service kits

Parts marked with  are included in the service kits.

Recommended Spare Parts: Service kits. ^(900732/1)

Conversion single to flushed shaft seal : Please order Flushed service kit + pos. 23+24+25+26



CSI

CONTACT CSI FOR MORE INFORMATION | CSIDESIGNS.COM | SALES@CSIDESIGNS.COM | 417.831.1411

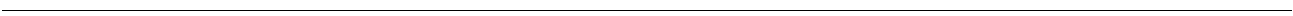

CSI

CONTACT CSI FOR MORE INFORMATION | CSIDESIGNS.COM | SALES@CSIDESIGNS.COM | 417.831.1411

How to contact Alfa Laval

Contact details for all countries are continually updated on our website.

Please visit www.alfalaval.com to access the information directly.

© Alfa Laval Corporate AB

This document and its contents is owned by Alfa Laval Corporate AB and protected by laws governing intellectual property and thereto related rights. It is the responsibility of the user of this document to comply with all applicable intellectual property laws. Without limiting any rights related to this document, no part of this document may be copied, reproduced or transmitted in any form or by any means (electronic, mechanical, photocopying, recording, or otherwise), or for any purpose, without the expressed permission of Alfa Laval Corporate AB. Alfa Laval Corporate AB will enforce its rights related to this document to the fullest extent of the law, including the seeking of criminal prosecution.



CSI

CONTACT CSI FOR MORE INFORMATION | CSIDESIGNS.COM | SALES@CSIDESIGNS.COM | 417.831.1411