

# Instruction Manual

## LKH Centrifugal Pump

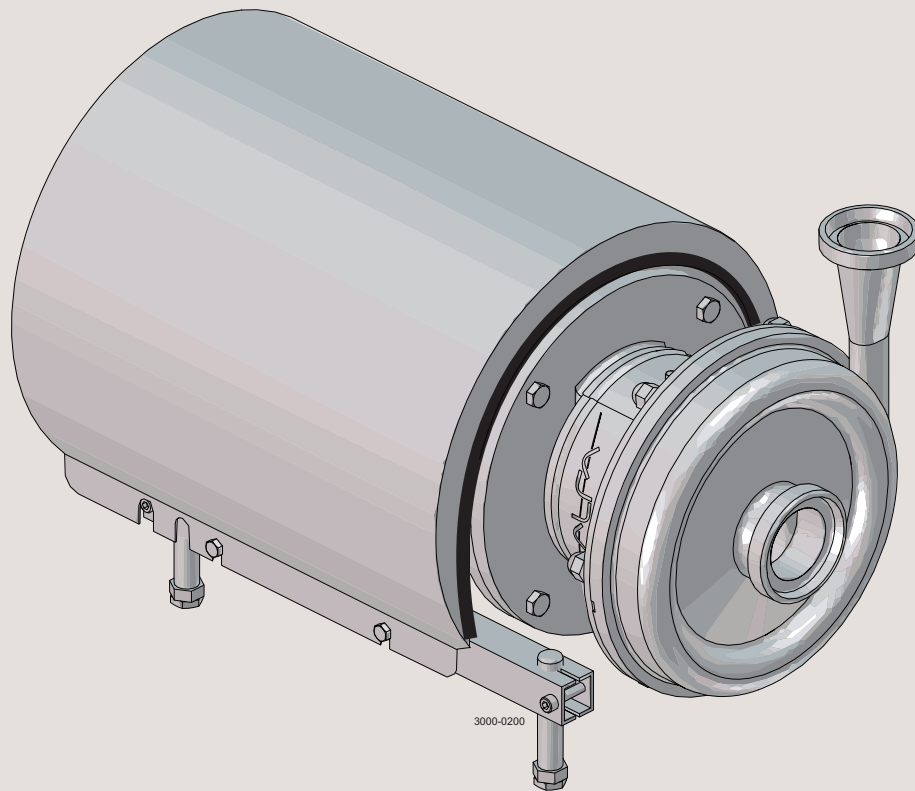



**CSI**

CONTACT CSI FOR MORE INFORMATION | [CSIDESIGNS.COM](http://CSIDESIGNS.COM) | [SALES@CSIDESIGNS.COM](mailto:SALES@CSIDESIGNS.COM) | 417.831.1411

# Table of contents

The information herein is correct at the time of issue but may be subject to change without prior notice

<b>1. EC Declaration of Conformity</b> .....	<b>4</b>
<b>2. Safety</b> .....	<b>5</b>
2.1. Important information .....	5
2.2. Warning signs .....	6
2.3. Safety precautions .....	7
<b>3. Installation</b> .....	<b>9</b>
3.1. Unpacking/delivery .....	9
3.2. Installation .....	11
3.3. Pre-use check - pump without impeller screw .....	17
3.4. Pre-use check - pump with impeller screw .....	19
3.5. Recycling information .....	20
<b>4. Operation</b> .....	<b>21</b>
4.1. Operation/Control .....	21
4.2. Trouble shooting .....	23
4.3. Recommended cleaning .....	24
<b>5. Maintenance</b> .....	<b>26</b>
5.1. General maintenance .....	26
5.2. Cleaning Procedure .....	28
5.3. Dismantling of pump/shaft seals .....	29
5.4. Assembly of pump/single shaft seal .....	32
5.5. Assembly of pump/flushed shaft seal .....	35
5.6. Assembly of pump/double mechanical shaft seal .....	38
5.7. Adjustment of shaft (LKH-5) .....	41
5.8. Adjustment of shaft (LKH-10 to -90) .....	43
<b>6. Technical data</b> .....	<b>45</b>
6.1. Technical data .....	45
6.2. Relubrication intervals .....	46
6.3. Torque Specifications .....	46
6.4. Weight (kg) .....	46
6.5. Noise emission .....	47
<b>7. Parts list and service kits</b> .....	<b>48</b>
7.1. LKH-5 Sanitary version .....	48
7.2. LKH-10, -15, -20, -25, -35, -40, -50, -60, -70, -75, -85, -90 sanitary version .....	49
7.3. LKH - Product wetted parts .....	50
7.4. LKH - Motor-dependent parts .....	52
7.5. LKH - Shaft seal .....	54



# 1 EC Declaration of Conformity

Revision of Declaration of Conformity 2013-12-03

The Designated Company

Alfa Laval Kolding A/S

Company Name

Albuen 31, DK-6000 Kolding, Denmark

Address

+45 79 32 22 00

Phone No.

hereby declare that

Pump

Designation

LKH-5, LKH-10, LKH-15, LKH-20, LKH-25, LKH-35, LKH-40, LKH-45, LKH-50, LKH-60, LKH-70, LKH-85, LKH-90

Type

Serial number from AAB000000001 to AAB999999999

Serial number from 10.000 to 1.000.000

Serial number from 100700000001-100799999999

is in conformity with the following directive with amendments:

- Machinery Directive 2006/42/EC

The person authorised to compile the technical file is the signer of this document

Global Product Quality Manager  
Hygienic Fluid Handling

Title

Lars Kruse Andersen

Name

Kolding  
Place

2020-01-23  
Date

Signature



---

*Unsafe practices and other important information are emphasised in this manual.  
Warnings are emphasised by means of special signs.  
Always read the manual before using the pump!*

---

### 2.1 Important information

---

#### **WARNING**

Indicates that special procedures must be followed to avoid serious personal injury.

#### **CAUTION**

Indicates that special procedures must be followed to avoid damage to the pump.

#### **NOTE**

Indicates important information to simplify or clarify procedures.

---

This Instruction manual is designed to provide the user with the information to perform tasks safely for all phases in the life time of the product supplied.

The User shall always read the safety section first. Hereafter the User can skip to the relevant section for the task to be carried out or for the information needed.

This is the complete manual for the supplied product.

**Skills for personal:**

**Operators:**

The operators shall read and understand the instruction manual for the supplied product

**Maintenance personnel:**

The maintenance personnel shall read and understand the instruction manual.

The maintenance personnel or technicians shall be skilled within the field required to carry out the maintenance work safely.

**Trainees:**

Trainees can perform tasks under the supervision of an experienced employee.

**People in general:**

The public shall not have access to the supplied product.

---

#### **How to contact Alfa Laval**

Contact details for all countries are continually updated on our website.

Please visit [www.alfalaval.com](http://www.alfalaval.com) to access the information directly.



**CSI**

CONTACT CSI FOR MORE INFORMATION | [CSIDESIGNS.COM](http://CSIDESIGNS.COM) | [SALES@CSIDESIGNS.COM](mailto:SALES@CSIDESIGNS.COM) | 417.831.1411

## 2 Safety

---

*Unsafe practices and other important information are emphasised in this manual.*

*Warnings are emphasised by means of special signs.*

***Always read the manual before using the pump!***

---

### 2.2 Warning signs

---

General warning:



Dangerous electrical voltage:



Caustic agents:



All warnings in the manual are summarised on this page.

Pay special attention to the instructions below so that severe personal injury and/or damage to the pump are avoided.

## 2.3 Safety precautions

### General

**Always** ensure that personnel must have experience with lifting operations.

**Always** ensure the lifting point to be in line with center of gravity. Adjust lifting point if necessary.

**Always** keep an eye on the load and stay clear during the lifting operation.

**Always** ensure that the lifting equipment is suitable for the specific pump.

**Always** use appropriate lifting equipment for heavy parts when relevant. Use lifting logs when applied.

To prevent unexpected start and contact with electrical live and moving parts.

**Always** disconnect the power supply safely:

- The power supply disconnecting device must be disconnected (in off position) and locked.

- In case the pump is capable of being plugged into an electrical supply, removal of the plug is sufficient, provided that the operator can check from any of the points to which he has access that the plug remains removed.

**Always** refer to the motor instruction manual for installation and maintenance of the motor.

**Never** touch the impeller through the inlet/outlet during start/stop as this can cause serious injury.

### Installation:

**Always** read the technical data thoroughly. (See chapter 6 Technical data)



#### Pump without impeller screw:

**Always** remove the impeller before checking the direction of rotation.

**Never** start the pump if the impeller is fitted and the pump casing is removed.

#### Pump with Impeller screw:

**Never** start in the wrong direction of rotation with liquid in the pump.

**Always** have the pump electrically connected by authorised personnel. (See the motor instruction)



### Operation:

**Always** read the technical data thoroughly. (See chapter 6 Technical data)

**Never** touch the pump or the pipelines when pumping hot liquids or when sterilising.

**Never** run the pump with both the suction side and the pressure side blocked.

**Never** run the pump when partially installed or not completely assembled.



**Necessary** precautions must be taken if leakage occurs as this can lead to hazardous situations.

**Always** handle lye and acid with great care.

**Never** use the pump for products not mentioned in the Alfa Laval pump selection program.

The Alfa Laval pump selection program can be acquired from your local Alfa Laval sales company.



### Maintenance:

**Always** read the technical data thoroughly. (See chapter 6 Technical data)

**Never** service the pump when it is hot.

**Never** service the pump if pressurised.

**Always** use Alfa Laval genuine spare parts.



#### Motors with grease nipples:

**Always** lubricate according to motor manufactures recommended procedures.

**Always** locate and remove grease vent plugs, if provided, prior to adding grease.

**Always** check motor nameplate for grease type and lubrication intervals.



CSI

CONTACT CSI FOR MORE INFORMATION | CSIDESIGNS.COM | SALES@CSIDESIGNS.COM | 417.831.1411

## 2 Safety

---

*All warnings in the manual are summarised on this page.*

*Pay special attention to the instructions below so that severe personal injury and/or damage to the pump are avoided.*

---

### Transportation:

#### Transportation of the pump or the pump unit:

**Never** lift or elevate in any way other than described in this manual

**Always** drain the pump head and accessories of any liquid

**Always** ensure that no leakage of lubricants can occur

**Always** transport the pump in its upright position

**Always** ensure that the unit is securely fixed during transportation

**Always** use the original packaging or similar during transportation

**Always** use suitable transport device ie. forklift or pallet lifter

---

### Storage:

Ideally as a guide Alfa Laval would recommend:

- Store supplied product as supplied in original packaging
  - Port opening should be protected against any ingress
  - Bare steel (not stainless) should be lightly oiled/greased
  - Store in a clean, dry place without direct sunlight or UV light
  - Temperature range -5 to 40°C
  - Relative humidity less than 60%
  - No exposure to corrosive substances (also air contained)
- 



**CSI**

CONTACT CSI FOR MORE INFORMATION | [CSIDESIGNS.COM](http://CSIDESIGNS.COM) | [SALES@CSIDESIGNS.COM](mailto:SALES@CSIDESIGNS.COM) | 417.831.1411



#### 3.1 Unpacking/delivery

##### Step 1

Always use a lifting crane when handling the pump (see technical data).

##### CAUTION

Alfa Laval cannot be held responsible for incorrect unpacking.

##### WARNING:

Be aware that certain pump configurations can tilt, and therefore cause injuries to feet or fingers. The pump should be supported underneath the adaptor, when not installed in the process line.

##### Check the delivery for:

1. Complete pump.
2. Delivery note.
3. Motor instructions.

##### Step 2

Remove any packing materials from the inlet and the outlet.  
Avoid damaging the inlet and the outlet.  
Avoid damaging the connections for flushing liquid, if supplied.

\*) Remove packing materials!

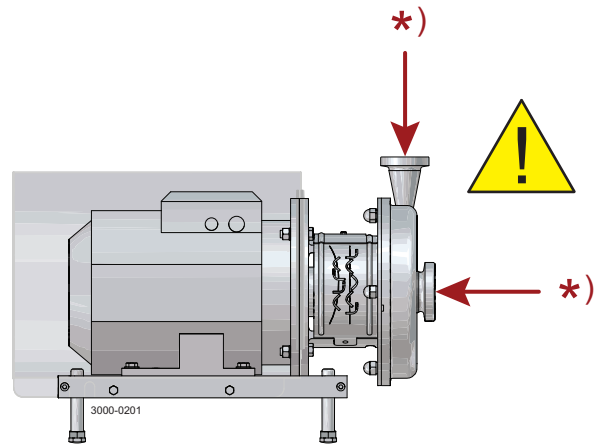

##### Step 3

Inspect the pump for visible transport damage.

\*) Remove packing materials!

Inspection!

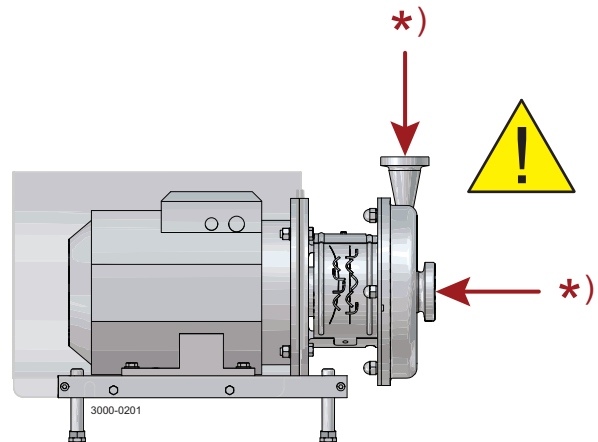

### 3 Installation

---

#### Step 4

Always remove the shroud, if fitted, before lifting the pump.

Remove the shroud before lifting!

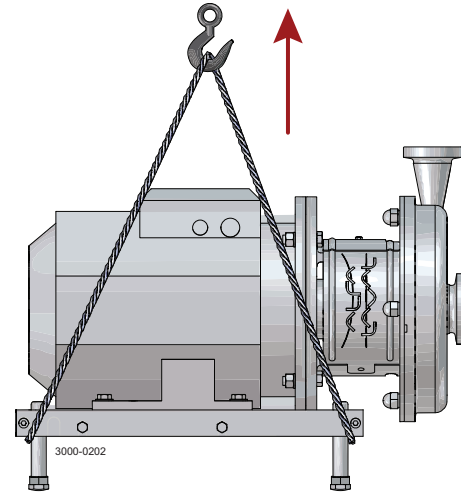

#### Step 5

**ONLY LKH-85 and LKH-90**

Do **NOT** use eyebolt in casing to lift the pump. The eyebolt is for casing removal only.

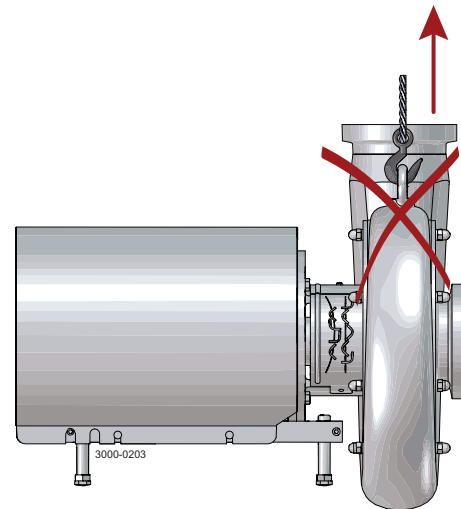

Read the instructions carefully and pay special attention to the warnings! Always check the pump before operation.  
- See pre-use check in section 3.3 Pre-use check - pump without impeller screw.  
The large pump sizes are very heavy.  
Alfa Laval therefore recommends the use of a lifting crane when handling the pump.

### 3.2 Installation

#### Step 1



**Always** read the technical data thoroughly.  
(See chapter 6 Technical data)



**Always** use a lifting crane when handling the pump.

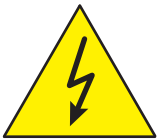

**Always** have the pump electrically connected by authorised personnel. (See the motor instructions).

#### CAUTION

Alfa Laval cannot be held responsible for incorrect installation.

#### CAUTION

The pump does not prevent back flow when intentionally or unintentionally stopped. If back flow can cause any hazardous situations, precautions must be taken e.g. check the valve to be installed in the system preventing hazardous situations from arising.

#### CAUTION

If the pump has been stored for longer period of time there is a risk that the seal faces may stick together and consequently cause damage to the seal at start-up. Please ensure that the pump shaft can be rotated by hand before start-up.

#### WARNING:

Alfa Laval recommends the supply disconnecting device shall be in accordance with EN60204-1. Always disconnect the supply disconnecting device safely after installation before continuing the installation.

#### Step 2

Ensure at least 0.5 m (1.6 ft) clearance around the pump.

Ensure the floor/frame is able to support the weight of the pump.  
See Technical data and other environment requirements in section 6.

Ensure the pump is supported by all four feet equally.

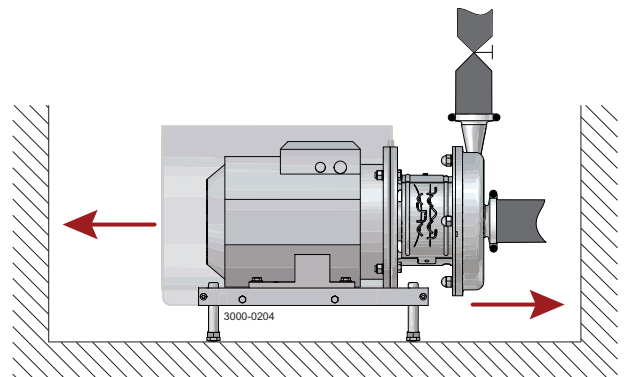

### 3 Installation

Read the instructions carefully and pay special attention to the warnings! Always check the pump before operation.

- See pre-use check in section 3.3 Pre-use check - pump without impeller screw.

The large pump sizes are very heavy.

Alfa Laval therefore recommends the use of a lifting crane when handling the pump.

#### Step 3

Check that the flow direction is correct.

O: Outlet

I: Inlet

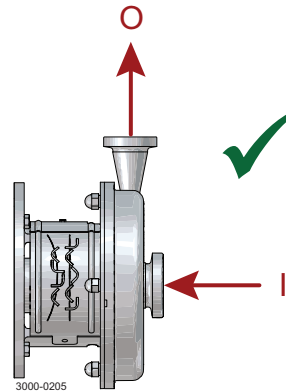

#### Step 4

1. Ensure that the pipelines are routed correctly.
2. Ensure that the connections are tight.
3. Remember seal rings. Few bends

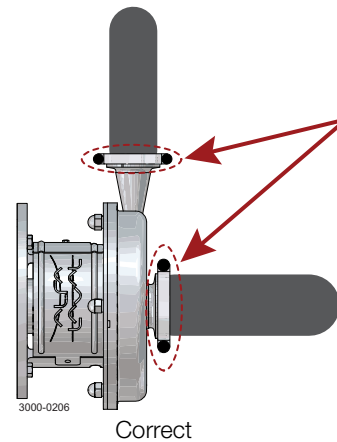

#### Step 5

Avoid stress on the pump.

Piping system must be self-supported.

Pay special attention to:

- Vibrations.
- Thermal expansion of the tubes.
- Excessive welding.
- Overloading of the pipelines.

Example of piping system self-supported.

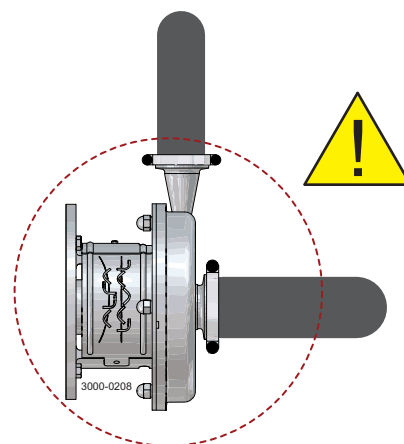
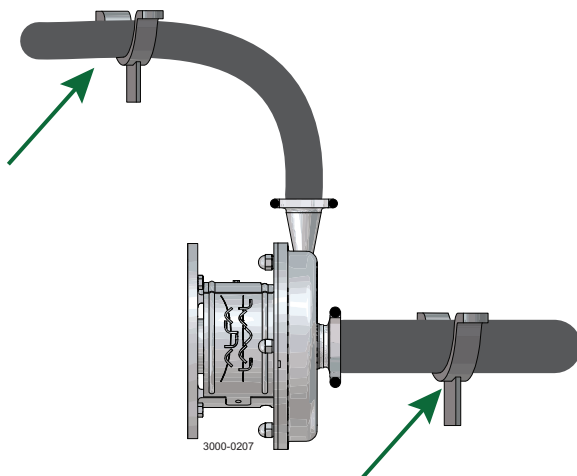

CSI

CONTACT CSI FOR MORE INFORMATION | CSIDESIGNS.COM | SALES@CSIDESIGNS.COM | 417.831.1411

### 3 Installation

Read the instructions carefully and pay special attention to the warnings! Always check the pump before operation.  
- See pre-use check in section 3.3 Pre-use check - pump without impeller screw.  
The large pump sizes are very heavy.  
Alfa Laval therefore recommends the use of a lifting crane when handling the pump.

#### Step 6

Ensure correct alignment of pump inlet and outlet with piping system.

Alignment can be done by adjusting the pump legs.

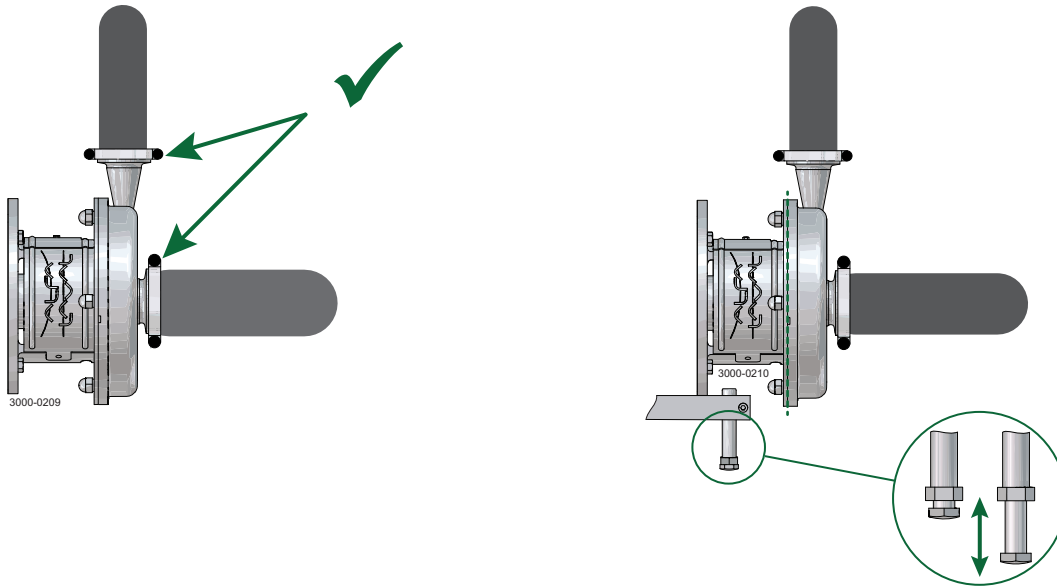

Centre of inlet and outlet to be aligned with centre of piping system.

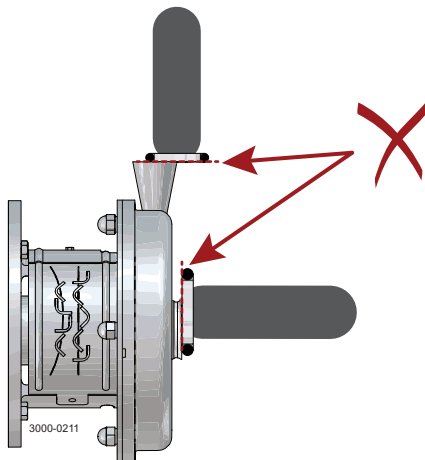

CSI

CONTACT CSI FOR MORE INFORMATION | CSIDESIGNS.COM | SALES@CSIDESIGNS.COM | 417.831.1411

### 3 Installation

Read the instructions carefully and pay special attention to the warnings! Always check the pump before operation.

- See pre-use check in section 3.3 Pre-use check - pump without impeller screw.

The large pump sizes are very heavy.

Alfa Laval therefore recommends the use of a lifting crane when handling the pump.

No gaps between connections on pump inlet and inlet pipe, and pump outlet and outlet pipe.

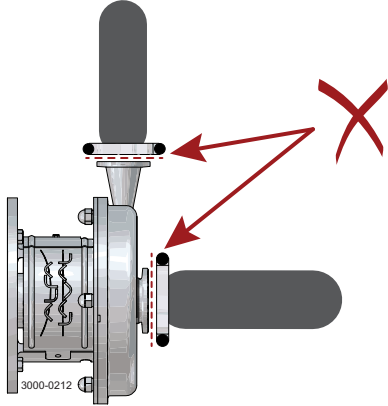

Angle between connections on pump inlet and inlet pipe, pump outlet and outlet pipe not allowed.

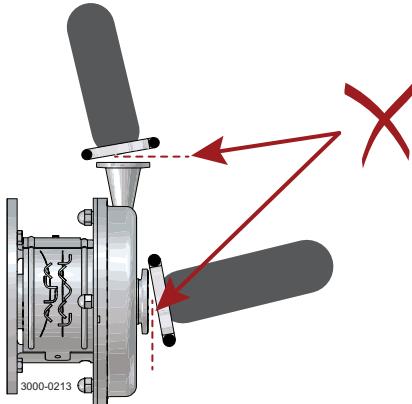

Ensure correct alignment of pump casing and pump backplate. Angle not allowed. Alignment can be done by adjusting the pump legs.

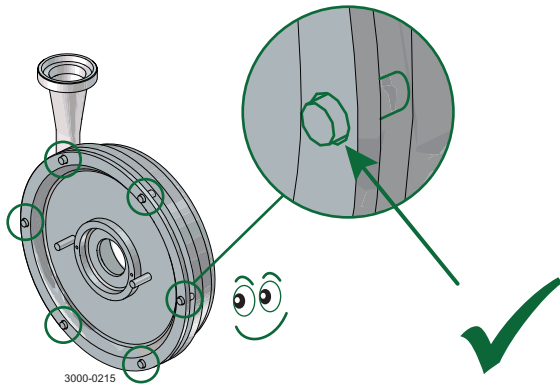

### 3 Installation

Read the instructions carefully and pay special attention to the warnings! Always check the pump before operation.

- See pre-use check in section 3.3 Pre-use check - pump without impeller screw.

The large pump sizes are very heavy.

Alfa Laval therefore recommends the use of a lifting crane when handling the pump.

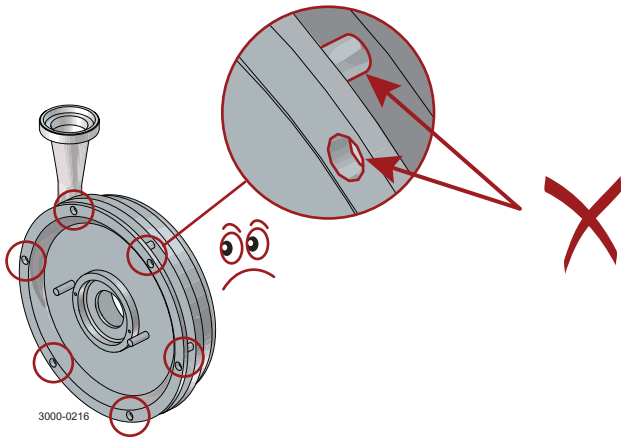

Ensure stud bolts in casing are aligned with holes in backplate.

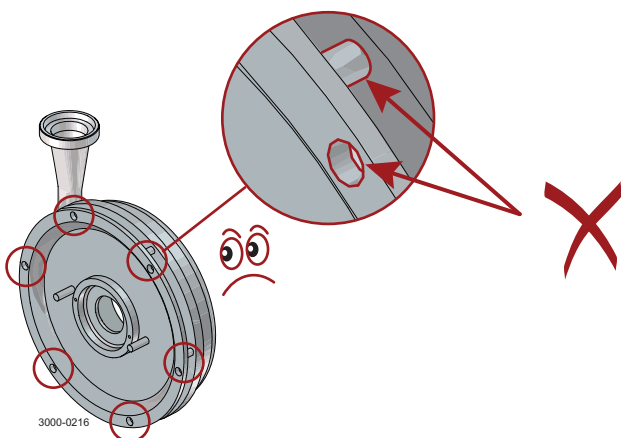
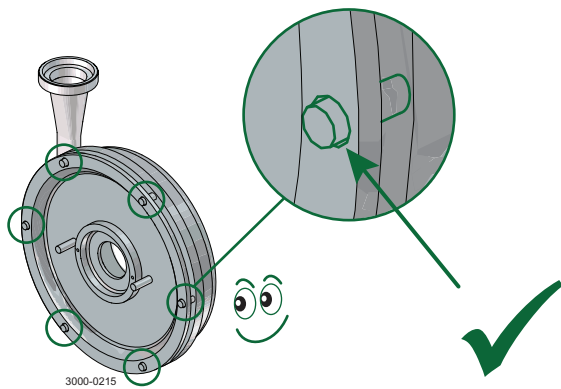

#### Note

In case of shaft seal leakage, the media will drip from the slot in the bottom of the adaptor. In case of shaft seal leakage, Alfa Laval recommends putting a drip tray underneath the slot to collect the leakage.

### 3 Installation

---

*Read the instructions carefully and pay special attention to the warnings! Always check the pump before operation.*

*- See pre-use check in section 3.3 Pre-use check - pump without impeller screw.*

*The large pump sizes are very heavy.*

*Alfa Laval therefore recommends the use of a lifting crane when handling the pump.*

---

Always ensure the adaptor shield and motor fan guard are present and mounted correctly and allow no access to rotating parts before installing and starting the pump.

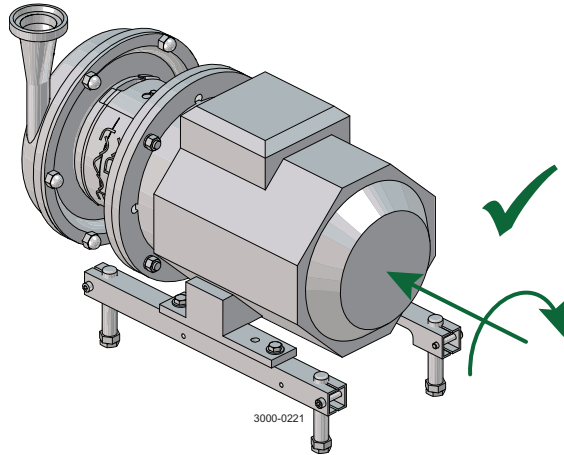

**CSI**

CONTACT CSI FOR MORE INFORMATION | [CSIDESIGNS.COM](http://CSIDESIGNS.COM) | [SALES@CSIDESIGNS.COM](mailto:SALES@CSIDESIGNS.COM) | 417.831.1411



Read the instructions carefully and pay special attention to the warnings!  
LKH-5 to -60 comes without impeller screw as standard but can be supplied with one.  
Check the direction of rotation of the impeller before operation.  
- See the indication label on the pump.

### 3.3 Pre-use check - pump without impeller screw

#### Step 1



**Always** remove the impeller before checking the direction of rotation.



**Never** start the pump if the impeller is fitted and the pump casing is removed.

1. A. LKH-5: Remove screws (56), spring washers (56a), clamps (55+55a) and pump casing (29).  
B. LKH-10 to -60: Remove cap nuts (24), washers (24a) and pump casing (29).
2. Remove impeller (27) (see also instruction in section 5.4 Assembly of pump/single shaft seal).

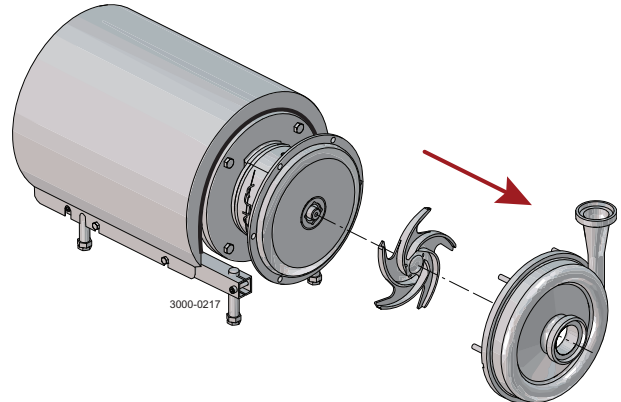

#### Step 2

**Warning:** Stay clear and ensure no one is near the shaft during test of rotation.

1. Connect power supply.
2. Start and stop the motor momentarily.
3. Ensure that the direction of rotation of the stub shaft (7) is anticlockwise as viewed from the inlet side.
4. Disconnect power supply safety.

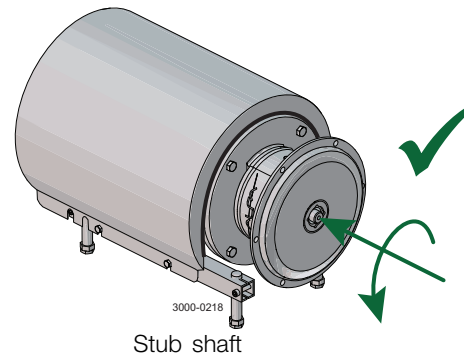

#### Step 3

Fit and tighten impeller (27).

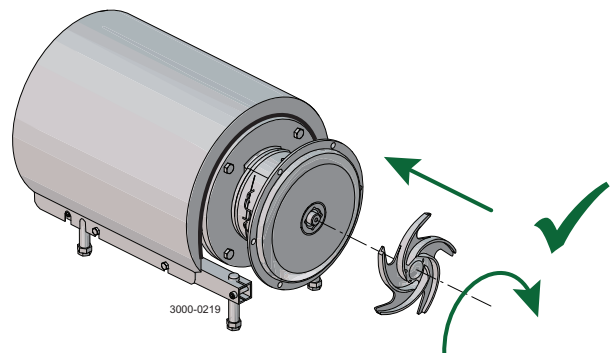

### 3 Installation

---

*Read the instructions carefully and pay special attention to the warnings!*  
*LKH-5 to -60 comes without impeller screw as standard but can be supplied with one.*  
*Check the direction of rotation of the impeller before operation.*  
*- See the indication label on the pump.*

---

#### Step 4

1. Fit pump casing (29).
2.
  - A. LKH-5: Fit clamps (55+55a), spring washers (56a) and tighten screws (56)
  - B. LKH-10 to -60: Fit washers (24a) and tighten cap nuts (24), according to torque values in chapter 6 Technical data

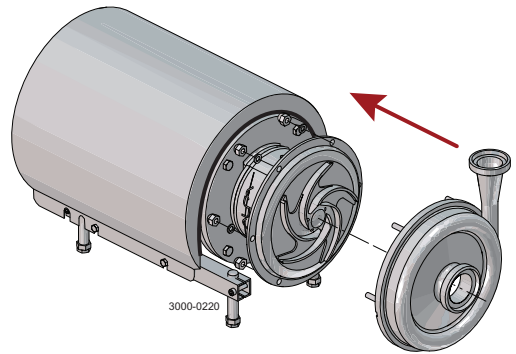

Read the instructions carefully and pay special attention to the warnings!  
LKH-5 to -60 comes without impeller screw as standard but can be supplied with one.  
Check the direction of rotation of the impeller before operation.  
- See the indication label on the pump.

### 3.4 Pre-use check - pump with impeller screw



**Never** start in the wrong direction of rotation with liquid in the pump.

1. Connect power supply
2. Start and stop the motor momentarily.
3. Ensure that the direction of rotation of the motor fan is clockwise as viewed from the rear end of the motor.
4. Disconnect power supply safely

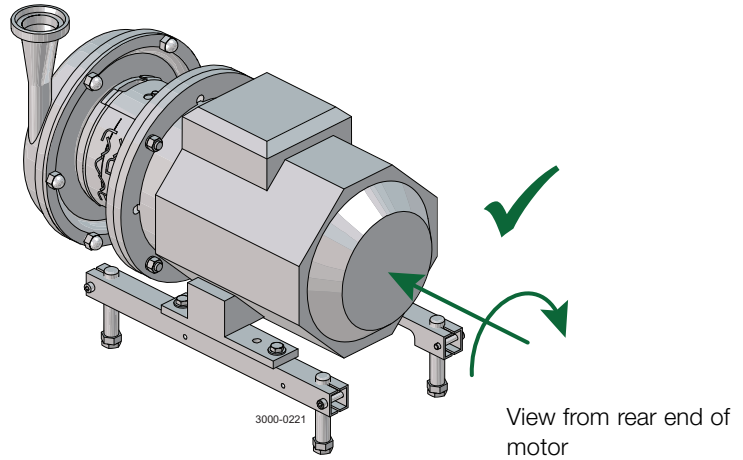

## 3 Installation

---

*Read the instructions carefully and pay special attention to the warnings!*

*LKH-5 to -60 comes without impeller screw as standard but can be supplied with one.*

*Check the direction of rotation of the impeller before operation.*

*- See the indication label on the pump.*

---

### 3.5 Recycling information

---

#### Unpacking

- Packing material consists of wood, plastics, cardboard boxes and in some cases metal straps
- Wood and cardboard boxes can be re-used, recycled or used for energy recovery
- Plastics should be recycled or burnt at a licensed waste incineration plant
- Metal straps should be sent for material recycling

#### Maintenance

- During maintenance, oil and wearing parts in the machine are replaced
- All metal parts should be sent for material recycling
- Worn out or defective electronic parts should be sent to a licensed handler for material recycling
- Oil and all non-metal wearing parts must be disposed of in accordance with local regulations

#### Scrapping

- At the end of use, the equipment must be recycled according to relevant local regulations. Besides the equipment itself, any hazardous residues from the process liquid must be taken into consideration and dealt with in a proper manner. When in doubt, or in the absence of local regulations, please contact your local Alfa Laval sales company.
- 



**CSI**

CONTACT CSI FOR MORE INFORMATION | [CSIDESIGNS.COM](http://CSIDESIGNS.COM) | [SALES@CSIDESIGNS.COM](mailto:SALES@CSIDESIGNS.COM) | 417.831.1411

Read the instructions carefully and pay special attention to the warnings!

## 4.1 Operation/Control

### Step 1



**Always** read the technical data thoroughly. See chapter 6 Technical data

#### CAUTION

Alfa Laval cannot be held responsible for incorrect operation/control.

### Step 2



**Never** touch the pump or the pipelines when pumping hot liquids or when sterilising.

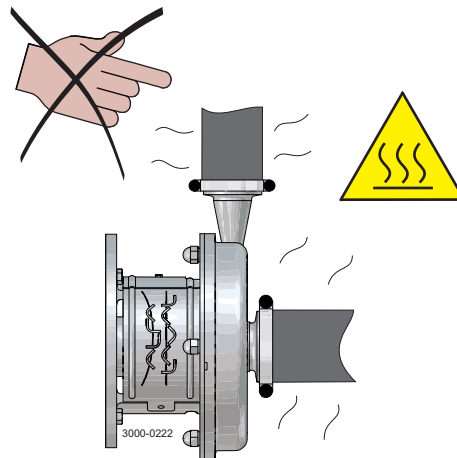

### Step 3



**Never** run the pump with both the suction side and the pressure side blocked.

**Danger of explosion!**

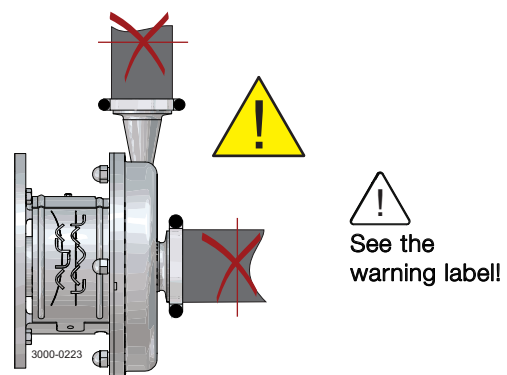

## 4 Operation

Read the instructions carefully and pay special attention to the warnings!

### Step 4

#### CAUTION

The shaft seal must not run dry.

#### CAUTION

Never throttle the inlet side.

\*) Do not allow to run dry

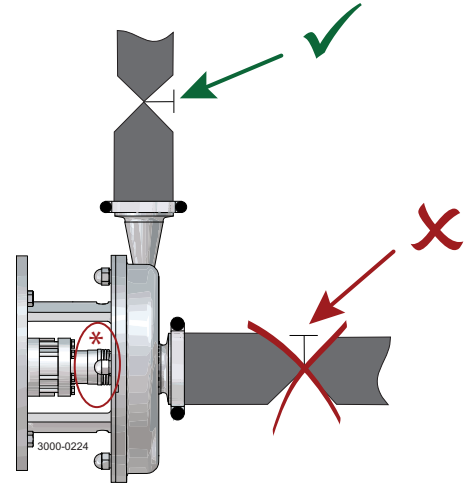

### Step 5

#### Double mechanical/flushed shaft seal:

1. Connect the inlet of the flushing liquid correctly. (1/8" G).
2. Regulate the water supply correctly.

\*For LKH-85: connect inlet/outlet of the flushing liquid directly on the flushing housing. (ø6 tube).

O: Outlet

I: Inlet

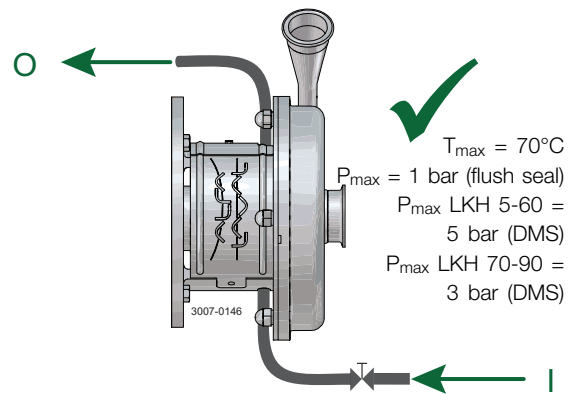

### Step 6

#### Control:

Reduce the capacity and the power consumption by means of:

- \*) Throttling the pressure side of the pump.
- Reducing the impeller diameter.
- Reducing the speed of the motor.

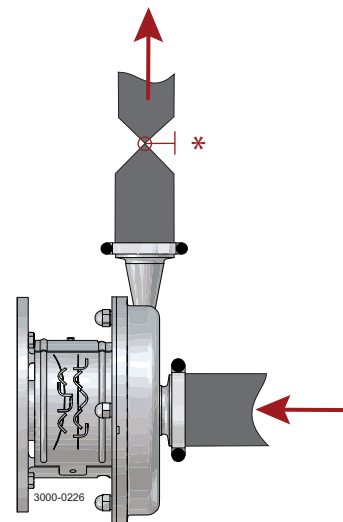

*Pay attention to possible faults.  
Read the instructions carefully.*

### 4.2 Trouble shooting

#### NOTE!

Read the maintenance instructions carefully before replacing worn parts.

Problem	Cause/result	Remedy
Motor overloaded	<ul style="list-style-type: none"> <li>- Pumping of viscous liquids</li> <li>- Pumping of high density liquids</li> <li>- Low outlet pressure (counter pressure)</li> <li>- Lamination of precipitates from the liquid</li> </ul>	<ul style="list-style-type: none"> <li>- Larger motor or smaller impeller</li> <li>- Higher counter pressure (throttling)</li> <li>- Frequent cleaning</li> </ul>
Cavitation: <ul style="list-style-type: none"> <li>- Damage</li> <li>- Pressure reduction (sometimes to zero)</li> <li>- Increase in the noise level</li> </ul>	<ul style="list-style-type: none"> <li>- Low inlet pressure</li> <li>- High liquid temperature</li> </ul>	<ul style="list-style-type: none"> <li>- Increase the inlet pressure</li> <li>- Reduce the liquid temperature</li> <li>- Reduce the pressure drop before the pump</li> <li>- Reduce speed</li> </ul>
Leaking shaft seal	<ul style="list-style-type: none"> <li>- Running dry</li> <li>- Incorrect rubber grade</li> <li>- Abrasive particles in the liquid</li> </ul>	Replace: All wearing parts  If necessary: <ul style="list-style-type: none"> <li>- Change rubber grade</li> <li>- Select stationary and rotating seal ring in silicon carbide/silicon carbide</li> </ul>
Leaking O-ring seals	Incorrect rubber grade	Change rubber grade

## 4 Operation

The pump is designed for cleaning in place (CIP). CIP = Cleaning In Place.  
Study the instructions carefully and pay special attention to the warnings!  
NaOH = Caustic Soda.  
HNO<sub>3</sub> = Nitric acid.

### 4.3 Recommended cleaning

#### Step 1



**Always** handle lye and acid with great care.  
**Always** follow the instructions in the safety data sheet for the cleaning agent.

Caustic danger!



Always use rubber gloves!



Always use protective goggles!

#### Step 2



**Never** touch the pump or the pipelines when sterilising.

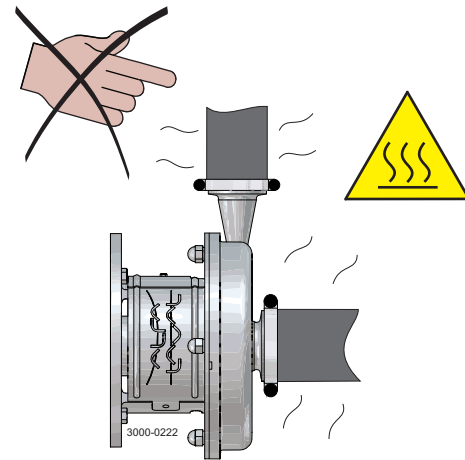

#### Step 3

**Examples of cleaning agents:** Use clean water, free from chlorides.

1. 1% by weight NaOH at 70°C (158°F).

1 kg (2.2 lb) NaOH + 100 l (26.4 gal) water = Cleaning agent.

2.2 l (0.6 gal) 33% NaOH + 100 l (26.4 gal) water = Cleaning agent.

2. 0.5% by weight HNO<sub>3</sub> at 70°C (158°F).

0.7 l (0.2 gal) 53% HNO<sub>3</sub> + 100 l (26.4 gal) water = Cleaning agent.

1. Avoid excessive concentration of the cleaning agent  
⇒ Dose gradually!
2. Adjust the cleaning flow to the process.  
Sterilisation of milk/viscous liquids  
⇒ Increase the cleaning flow!



CSI

CONTACT CSI FOR MORE INFORMATION | CSIDESIGNS.COM | SALES@CSIDESIGNS.COM | 417.831.1411



The pump is designed for cleaning in place (CIP). CIP = Cleaning In Place.  
Study the instructions carefully and pay special attention to the warnings!  
NaOH = Caustic Soda.  
HNO<sub>3</sub> = Nitric acid.

### Step 4



**Always** rinse well with clean water after using a cleaning agent.

#### NOTE

Cleaning agents must be stored/disposed of in accordance with current regulations/directives.

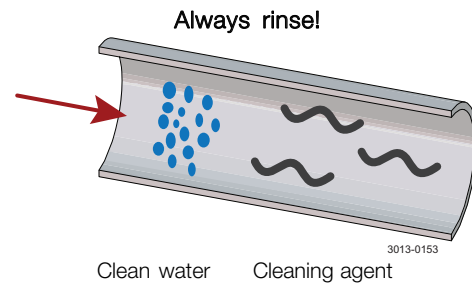

#### NOTE:

If pumps are sterilised using steam, standard 3A requires the process system to be designed to automatically shut down if the product pressure in the system becomes less than that of the atmosphere and it cannot be started until the system is re-sterilised.



## 5 Maintenance

Maintain the pump with care. Read the instructions carefully and pay special attention to the warnings!

Always keep spare shaft seals and rubber seals in stock.

See separate motor instructions.

Check the pump for smooth operation after service.

### 5.1 General maintenance

#### Step 1



**Always** read the technical data thoroughly. (See chapter 6 Technical data)



**Always** disconnect the power supply safely when servicing the pump.

#### NOTE

All scrap must be stored//disposed of in accordance with current rules/directives.

#### Step 2



**Never** service the pump when it is hot.

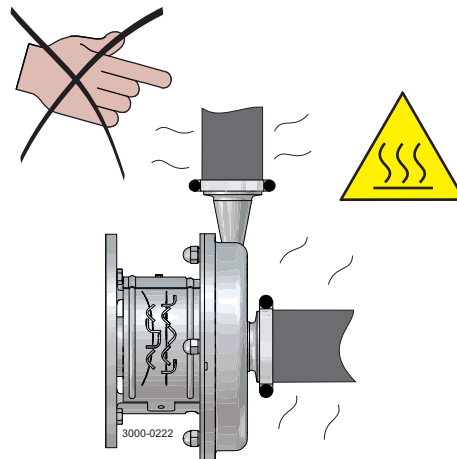

#### Step 3



**Never** service the pump when pump is pressurised.

#### CAUTION

Fit the electrical connections correctly if they have been removed from the motor during service.

#### CAUTION

Pay special attention to the warnings!

\*) Atmospheric pressure required!

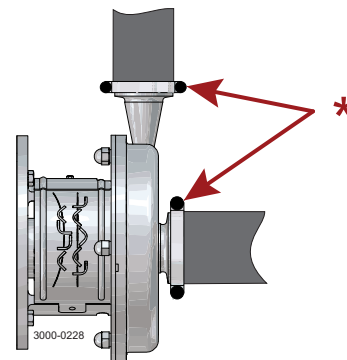

#### Step 4

##### Recommended spare parts:

Order service kits from the service kits list  
(See chapter 7 Parts list and service kits).

##### Ordering spare parts

Contact your local Alfa Laval sales company.

#### Note:

If the pump is supplied with FEP O-rings, Alfa Laval recommends that the casing O-ring is replaced during pump maintenance.



CSI

CONTACT CSI FOR MORE INFORMATION | CSIDESIGNS.COM | SALES@CSIDESIGNS.COM | 417.831.1411

## 5 Maintenance

Maintain the pump with care. Read the instructions carefully and pay special attention to the warnings!  
 Always keep spare shaft seals and rubber seals in stock.  
 See separate motor instructions.  
 Check the pump for smooth operation after service.

### Safety check

A visual inspection of adaptor shield and motor fan guard must be carried out every 12 months.  
 If loss or damage to shield or guard, especially when this leads to deterioration of safety performance, it shall be replaced.  
 The fixing of shield and guards should only be replaced with fixings of the same or an equivalent type.

### Inspection acceptance criteria:

- It is not possible to reach the shaft or fan
- The shield and guard must be securely mounted
- Ensure that the screws are tightened

### Procedure in case of non-acceptance:

- Fix and/or replace the shield or guard.

	Shaft seal	Rubber seals	Motor bearings
Preventive maintenance	<b>Replace after 12 months:</b> (one-shift) Complete shaft seal	Replace when replacing the shaft seal	
Maintenance after leakage (leakage normally starts slowly)	<b>Replace at the end of the day:</b> Complete shaft seal	Replace when replacing the shaft seal	
Planned maintenance	<ul style="list-style-type: none"> <li>- Regular inspection for leakage and smooth operation</li> <li>- Keep a record of the pump</li> <li>- Use the statistics for inspection planning</li> </ul> <b>Replace after leakage:</b> Complete shaft seal	Replace when replacing the shaft seal	Yearly inspection is recommended <ul style="list-style-type: none"> <li>- Replace complete bearing if worn</li> <li>- Ensure that the bearing is axially locked (See motor instructions)</li> </ul>
Lubrication (Use food approved greas or oil)	<b>Before fitting</b> Lubricate the O-rings with silicone grease or silicone oil	<b>Before fitting</b> Silicone grease or silicone oil	See section 6.2 Relubrication intervals

### Pre-use check

#### CAUTION!

Fit the electrical connections correctly if they have been removed from the motor during servicing.  
 (See pre-use check in section 3 Installation).

### Pay special attention to warnings!

1. Start and stop the motor momentarily
2. Ensure that the pump operates smoothly.



## 5 Maintenance

---

### 5.2 Cleaning Procedure

---

#### Cleaning procedure for soiled impeller screw tapped hole:

**Warning:** Always follow the instructions in the safety data sheet for the cleaning agent.

1. Remove stub shaft (7) as per section 4 of the Service manual.
2. Submerge and soak the stub shaft for 5 minutes in COP tank with 2% caustic wash
3. Scrub the blind tapped impeller screw hole vigorously by plunging a clean 1/2" diameter sanitary bristle pipe brush in and out of the hole for two minutes while submerged.
4. Soak stub shaft (7) in acid sanitiser for 5 minutes, then scrub blind tapped hole as described in step 3 above.
5. Rinse well with clean water and blow-dry blind tapped hole with clean air.
6. Swab test the inside of the tapped hole to determine cleanliness.
7. Should the swab test fail, repeat steps 2 to 6 above until the swab test is passed.

Should swab testing continue to fail, or time is of the essence, install a new (spare) stub shaft (7).

---



Read the instructions carefully. The items refer to the parts list and service kits section.

Handle scrap correctly.

\* : Relates to the shaft seal.

### 5.3 Dismantling of pump/shaft seals

#### Step 1

1.

- A. LKH-5: Remove screws (56), spring washers (56a), clamps (55+55a) and pump casing (29).
- B. LKH-10 to 90: Unscrew cap nuts (24) and remove washers (24a) and pump casing (29).

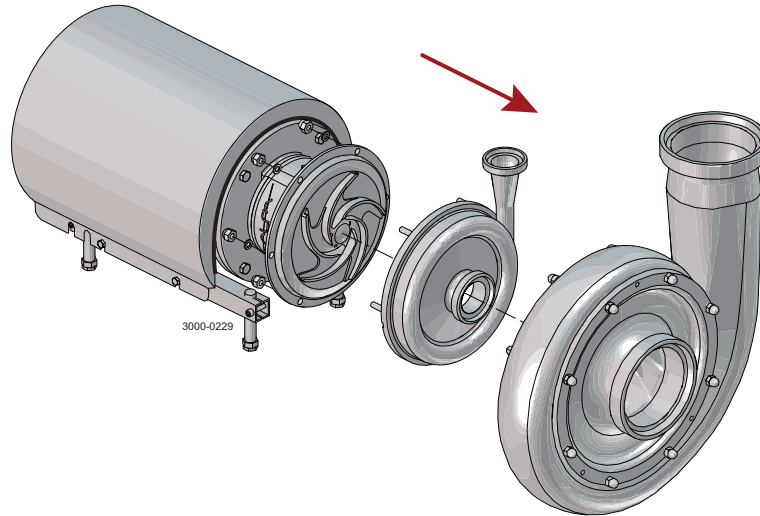

LKH-85 and LKH-90

#### Step 2

**Flushed / Double mechanical shaft seal:**

Unscrew tubes (42) using a spanner.

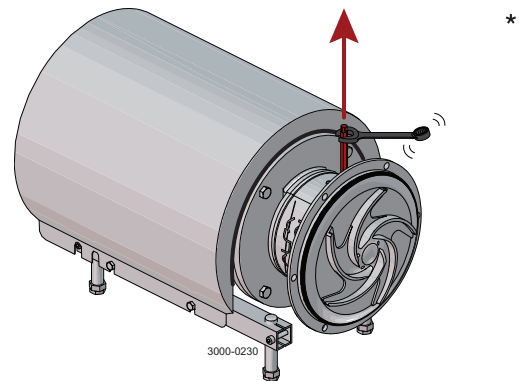

## 5 Maintenance

Read the instructions carefully. The items refer to the parts list and service kits section.

Handle scrap correctly.

\* : Relates to the shaft seal.

### Step 3

Remove screw (23) and safety guard (22).

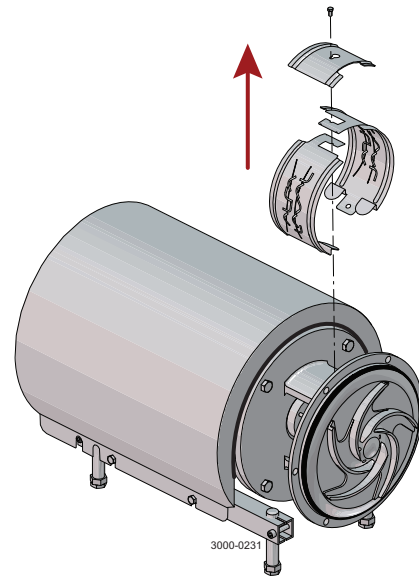

### Step 4

1. Remove impeller screw (36), if fitted.
2. Remove impeller (27). If necessary, loosen the impeller by knocking gently on the impeller vanes.
3. Remove the O-ring (38) from the impeller, if fitted.

\*) Counterhold with a screwdriver!

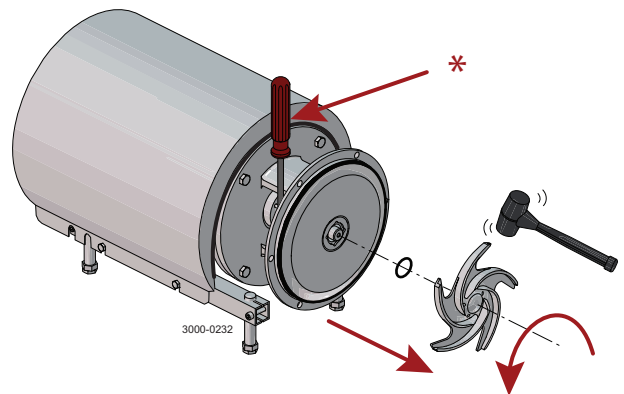

### Step 5

1. Pull off the O-ring (26) from back plate (25).
2. Unscrew nuts (20) and remove washers (21) and the back plate.

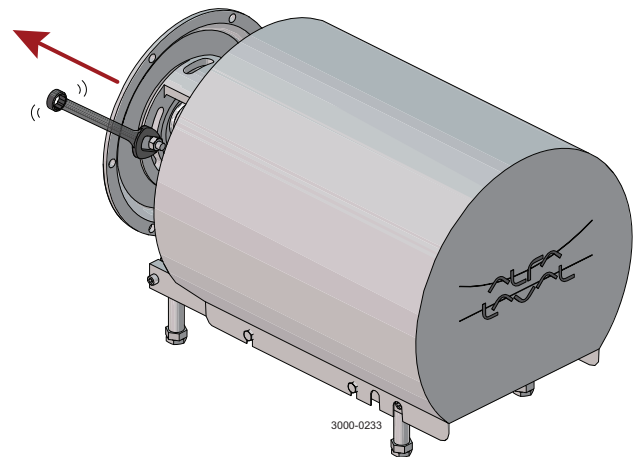

CSI

CONTACT CSI FOR MORE INFORMATION | CSIDESIGNS.COM | SALES@CSIDESIGNS.COM | 417.831.1411

Read the instructions carefully. The items refer to the parts list and service kits section.  
Handle scrap correctly.

\* : Relates to the shaft seal.

### Step 6

1. Remove the stationary seal ring (11).
2. Remove the O-ring (12) from back plate (25).

\*) Use the tool supplied. Left hand thread!

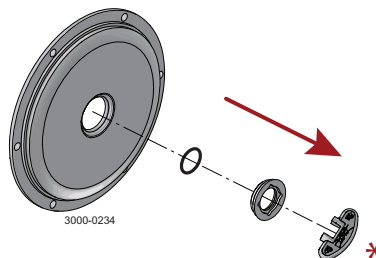

### Step 7

#### Flushed shaft seal:

1. Remove screws (41) and seal housing (40).
2. Pull out lip seal (43) from the seal housing.

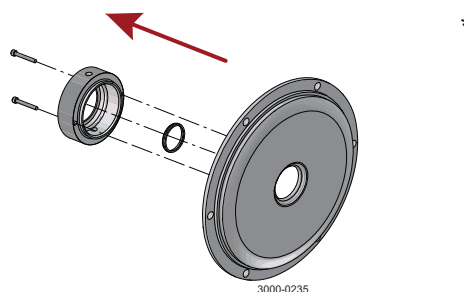

### Step 8

#### Double mechanical shaft seal:

1. Remove screws (41) and seal housing (40a).
2. Remove rotating seal rings (14) and drive ring (52) from spring (13).
3. Remove O-rings (15) from rotating seal rings (14).
4. LKH-70 to 90: Remove cups (54) from rotating seal rings.

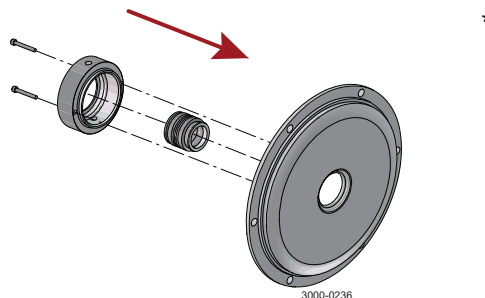

### Step 9

#### Double mechanical shaft seal:

1. Remove stationary seal ring (51) from seal housing (40a).
2. Remove O-ring (50) from stationary seal ring (51).
3. Remove O-ring (44) from seal housing (40a).

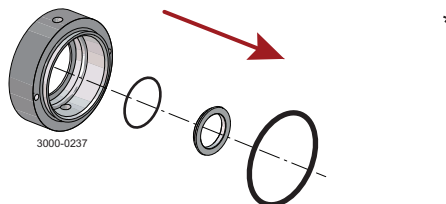

### Step 10

1. Remove the complete shaft seal from stub shaft (7).
2. Remove spring (13) and rotating seal ring (14) from the drive ring (10).

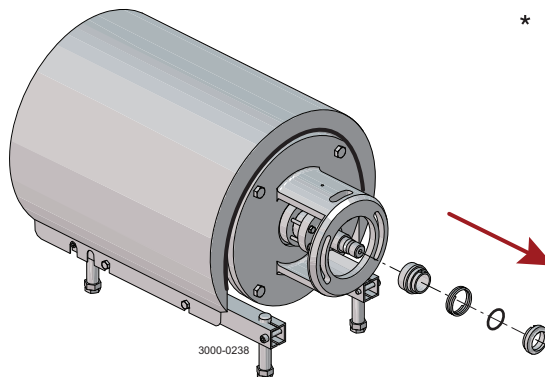

## 5 Maintenance

Read the instructions carefully. The items refer to the parts list and service kits section.

Handle scrap correctly.

\* : Relates to the shaft seal.

### 5.4 Assembly of pump/single shaft seal

#### Step 1

1. Remove spring (13).

#### NOTE!

Make sure that O-ring (15) has maximum clearance from the sealing surface.

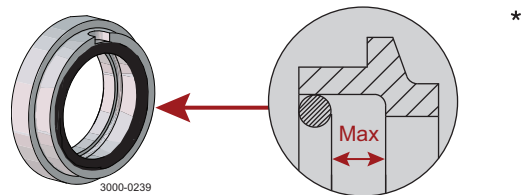

If change from double mechanical shaft seal to single shaft seal the shaft needs to be adjusted. see Section 5.7 Adjustment of shaft (LKH-5) and Section 5.8 Adjustment of shaft (LKH-10 to -90).

#### Step 2

1. Refit spring (13) on rotating seal ring (14).
2. Fit the spring and the rotating seal ring on drive ring (10).

#### CAUTION

Ensure that the driver on the drive ring enters the notch in the rotating seal ring.

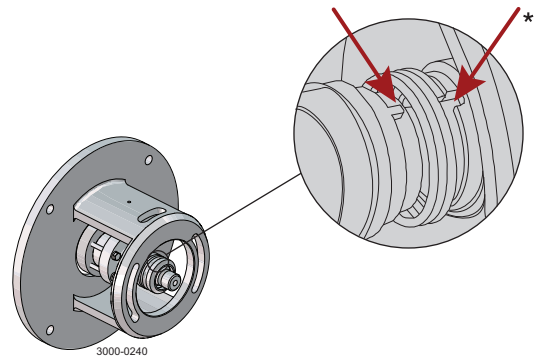

#### Step 3

- Fit the complete shaft seal on stub shaft (7).

#### NOTE!

Make sure that Connex pin (8) on the stub shaft enters the notch in drive ring (10).

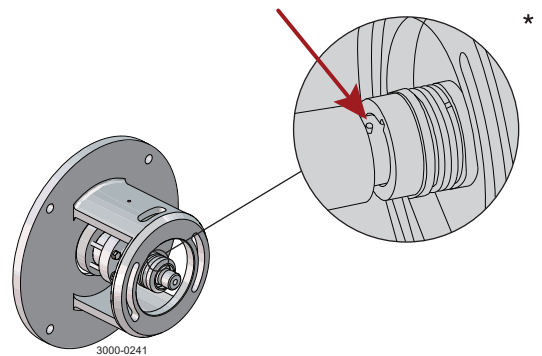

#### Step 4

1. Fit O-ring (12) on stationary seal ring (11) and lubricate.
2. Screw the stationary seal ring into back plate (25).

#### CAUTION

Only tighten by hand to avoid deforming the stationary seal ring.

(Max. 7 Nm/5 lbf-ft)

\*) Use the tool supplied. Left hand thread!

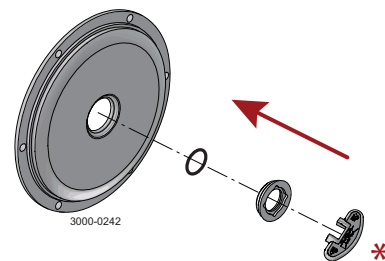



## 5 Maintenance

Read the instructions carefully. The items refer to the parts list and service kits section.

Handle scrap correctly.

\* : Relates to the shaft seal.

### Step 5

1. Clean the sealing surfaces with contact cleaner before fitting back plate (25).
2. Carefully guide the back plate onto adaptor (16).
3. Fit washers (21) and nuts (20).

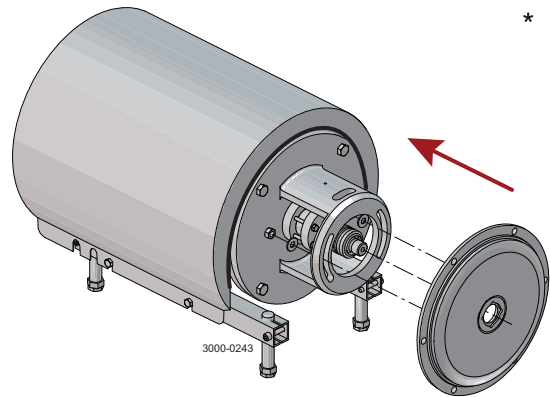

### Step 6

Lubricate O-ring (26) and slide it onto back plate (25).

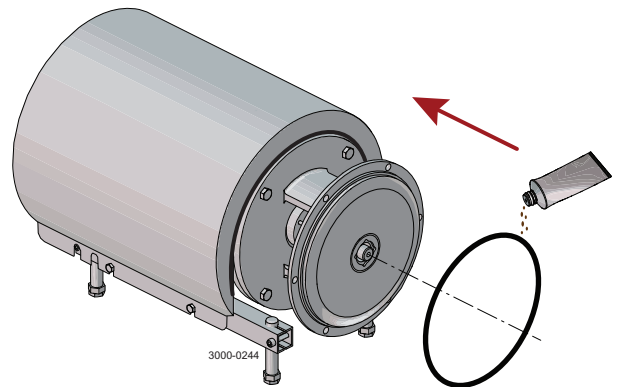

### Step 7

1. Lubricate O-ring (38) and fit it in impeller (37), if impeller screw is used.
  2. Lubricate impeller hub with silicone grease or oil.
  3. Screw the impeller onto stub shaft (7).
  4. Fit impeller screw (39) and tighten, if used.
- Torque - 5-60 = 20 Nm (15 lbf-ft)  
Torque - 70-90 = 50 Nm (37 lbf-ft)

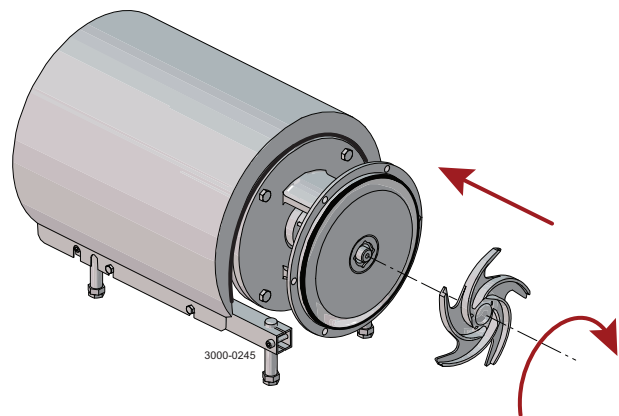

## 5 Maintenance

Read the instructions carefully. The items refer to the parts list and service kits section.

Handle scrap correctly.

\* : Relates to the shaft seal.

### Step 8

Fit safety guards (22) and screw (23) and tighten.

If pump is not supplied with flush connections, the holes in the adaptor will be covered by the guard.

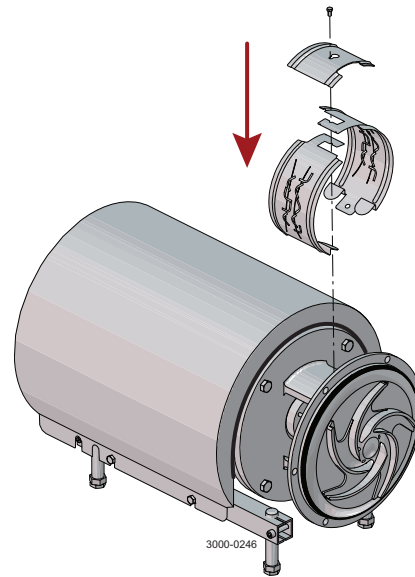

### Step 9

1.
  - A. LKH-5: Fit pump casing (29), clamps (55+55a), spring washers (56a) and screws (56).
  - B. LKH-10 to -90: Fit pump casing (29), washers (24a) and cap nuts (24).
2. Adjust pump casing to the right position.
3.
  - A. LKH-5: Tighten nuts (20) for back plate (25) and tighten screws (56).
  - B. LKH-10 to -90: Tighten nuts (20) for back plate (25) and tighten cap nuts (24), according to torque values in chapter 6 Technical data.

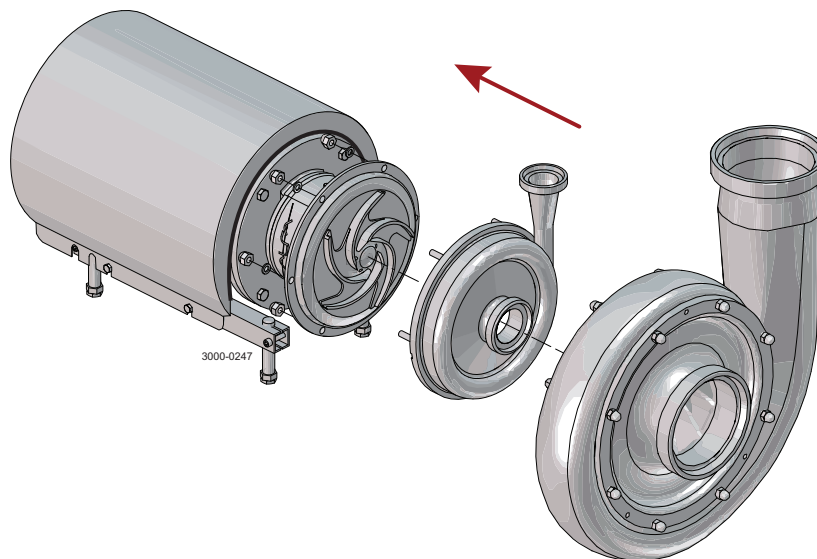

LKH-85 and LKH-90



CSI

CONTACT CSI FOR MORE INFORMATION | CSIDESIGNS.COM | SALES@CSIDESIGNS.COM | 417.831.1411

Read the instructions carefully. The items refer to the parts list and service kits section.

Lubricate the rubber seals before fitting them.

\* : Relates to the shaft seal.

## 5.5 Assembly of pump/flushed shaft seal

### Step 1

#### Flushed shaft seal:

LKH-5 to -60 use ø63mm tube

LKH-70 to -90 press in lip seal by hand

1. Fit lip seal (43) in seal housing (40).
2. Lubricate O-ring (44) and slide onto the seal housing (40).
3. Fit the seal housing on back plate (25) and tighten screws (41).

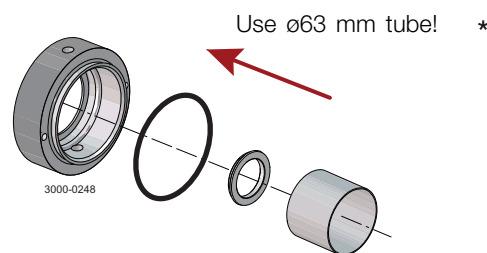

### Note

If change from double mechanical shaft seal to flushed shaft seal the shaft needs to be adjusted. see Section 5.7 Adjustment of shaft (LKH-5) and Section 5.8 Adjustment of shaft (LKH-10 to -90).

### Step 2

1. Lubricate O-ring (45) and fit it in drive ring (10).
2. Fit spring (13) and rotating seal ring (14) on the drive ring.

### CAUTION

Ensure that the driver on the drive ring enters the notch in the rotating seal ring.

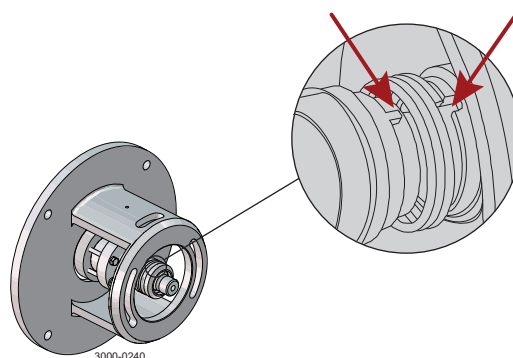

### Step 3

Fit complete shaft seal on stub shaft (7) so that Connex pin (8) on the stub shaft enters the notch in drive ring (10).

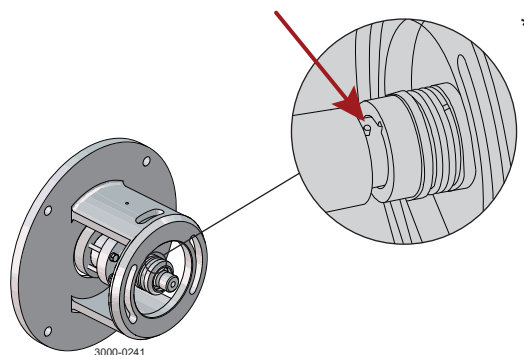

### Step 4

1. Carefully guide back plate (25) onto adaptor (16).
2. Fit washers (21) and nuts (20).

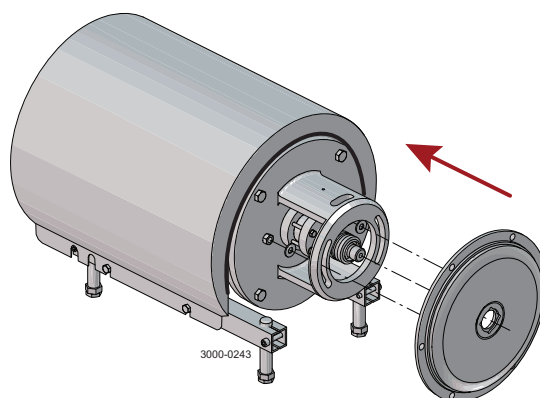

## 5 Maintenance

Read the instructions carefully. The items refer to the parts list and service kits section.

Lubricate the rubber seals before fitting them.

\* : Relates to the shaft seal.

### Step 5

Lubricate O-ring (26) and slide it onto back plate (25).

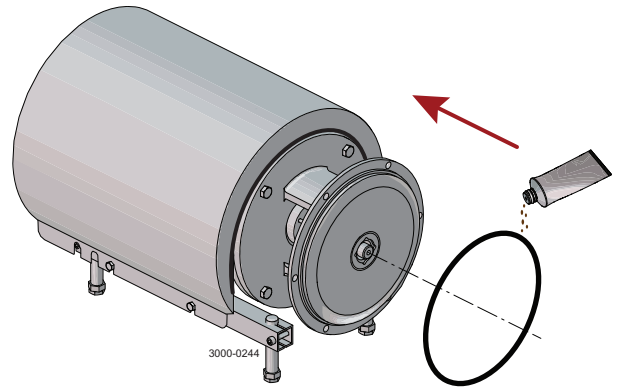

### Step 6

1. Lubricate O-ring (38) and fit it in impeller (37), if impeller screw is used.
  2. Lubricate the impeller hub with silicone grease or oil.
  3. Screw impeller (27) onto stub shaft (7).
  4. Fit impeller screw (36) and tighten, if used.
- Torque - 5-60 20 Nm (15 lbf-ft)  
Torque - 70-90 50 Nm (37 lbf-ft)

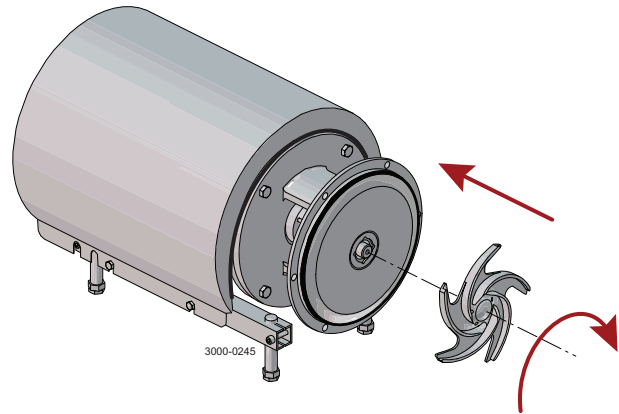

### Step 7

1. Screw tubes (42) into seal housing (40).
2. Tighten with a spanner.

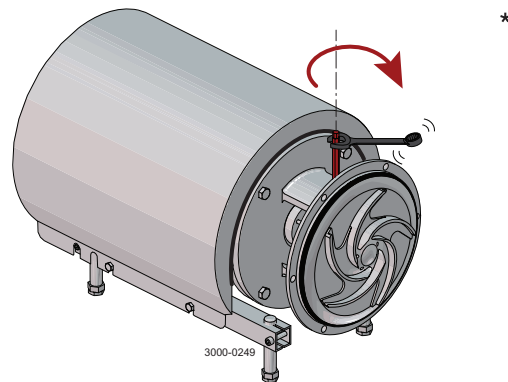

Read the instructions carefully. The items refer to the parts list and service kits section.

Lubricate the rubber seals before fitting them.

\* : Relates to the shaft seal.

### Step 8

Fit safety guard (22) and screw (23) and tighten.

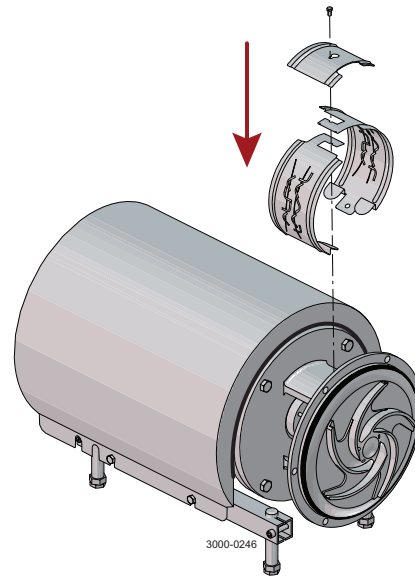

### Step 9

1.
  - A. LKH-5: Fit pump casing (29), clamps (55+55a), spring washers (56a) and screws (56).
  - B. LKH-10 to -90: Fit pump casing (29).
2. Tighten nuts (20) for back plate (25).
3.
  - A. LKH-5: Tighten nuts (20) for back plate (25) and tighten screws (56).
  - B. LKH-10 to -90: Fit washers (24a) and cap nuts (24) and tighten, according to the torque values in chapter 6 Technical data.

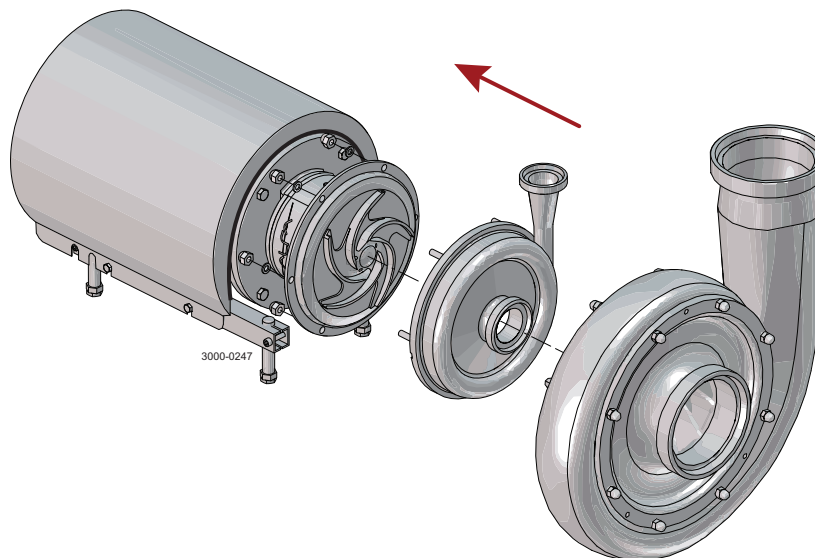

LKH-85 and LKH-90

## 5 Maintenance

Read the instructions carefully. The items refer to the parts list and service kits section.  
Lubricate the rubber seals before fitting them.

\* : Relates to the shaft seal.

### 5.6 Assembly of pump/double mechanical shaft seal

#### Step 1

1. Fit O-rings (15) in rotating seal rings (14). \*
2. LKH-70 to -90: Fit cups (54) on rotating seal rings (14).
3. Fit spring (13) on one of the rotating seal rings (14) and place the drive ring (52) in between.

#### Step 2

1. LKH-70 to -90: Turn the drive ring (52) in order to place it correctly on the pump shaft (7). \*
2. Fit the second rotating ring (14) on the other end of the spring.
3. Place the parts on the stationary seal ring fitted in back plate (25).

#### NOTE

Ensure that both drive pins on the drive ring enter the notches in rotating seal rings.

If change from single shaft seal to double mechanical shaft seal the shaft needs to be adjusted. see Section 5.7 Adjustment of shaft (LKH-5) and Section 5.8 Adjustment of shaft (LKH-10 to -90).

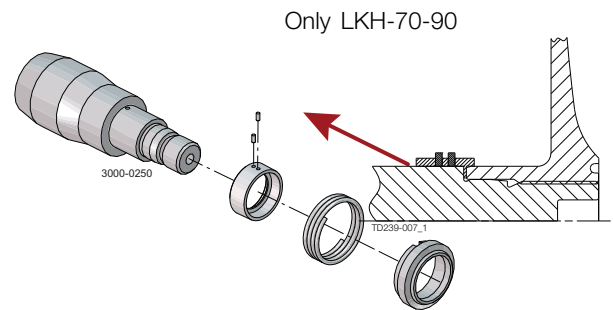

#### Step 3

1. Lubricate O-ring (44) and slide onto seal housing (40a). \*
2. Lubricate O-ring (50) and fit on stationary seal ring (51) and fit this in the seal housing.

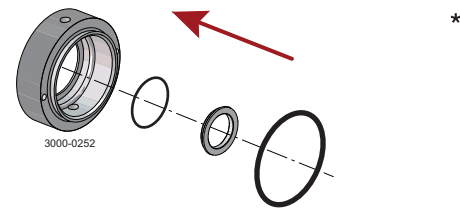

#### Step 4

1. Clean the sealing surfaces with contact cleaner. \*
2. Fit seal housing (40a) on the back plate (25) and tighten screws (41).

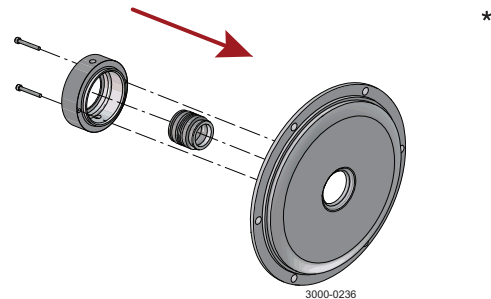

#### Step 5

1. To enable fitting of back plate (25) with the shaft seal, remove Connex pin (8) from stub shaft (7) (if fitted).
2. Carefully guide the back plate onto adaptor (16).
3. Fit washers (21) and nuts (20).

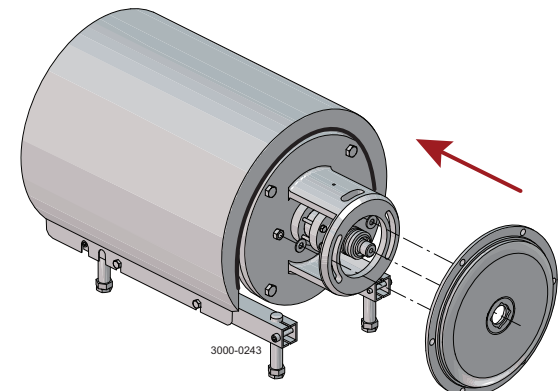

CSI

CONTACT CSI FOR MORE INFORMATION | CSIDESIGNS.COM | SALES@CSIDESIGNS.COM | 417.831.1411

## 5 Maintenance

Read the instructions carefully. The items refer to the parts list and service kits section.  
Lubricate the rubber seals before fitting them.

\* : Relates to the shaft seal.

### Step 6

Lubricate O-ring (26) and slide it onto back plate (25).

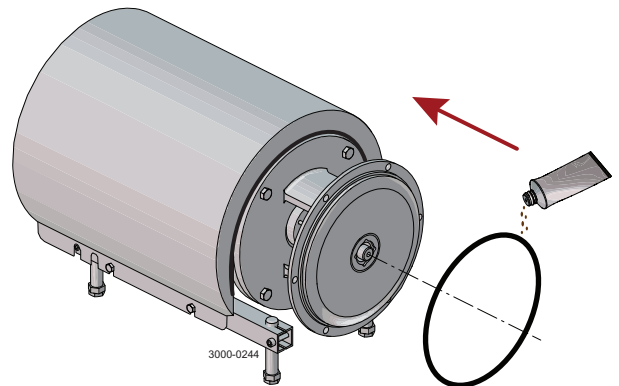

### Step 7

1. Lubricate O-ring (38) and fit it in impeller (37), if impeller screw is used.
  2. Lubricate the impeller hub with silicone grease or oil.
  3. Screw impeller (27) onto stub shaft (7).
  4. Fit impeller screw (36) and tighten, if used.
- Torque - 5-60 20 Nm (15 lbf-ft)  
Torque - 70-90 50 Nm (37 lbf-ft)

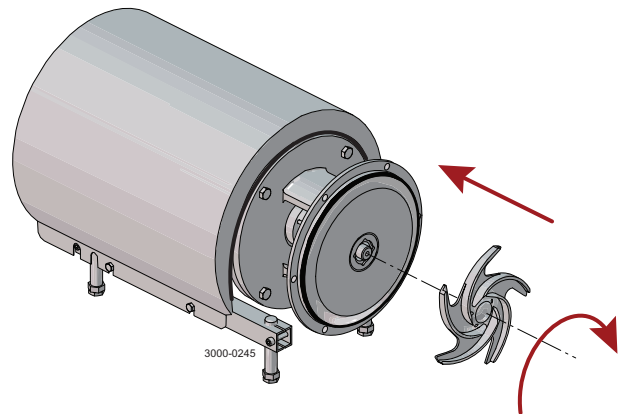

### Step 8

1. Screw tubes (42) into seal housing (40a).
2. Tighten with a spanner.

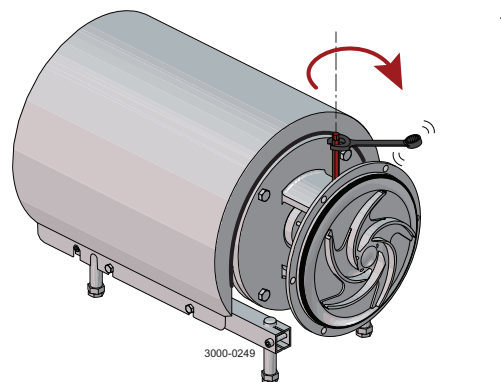

## 5 Maintenance

Read the instructions carefully. The items refer to the parts list and service kits section.

Lubricate the rubber seals before fitting them.

\* : Relates to the shaft seal.

### Step 9

Fit safety guard (22) and screw (23) and tighten.

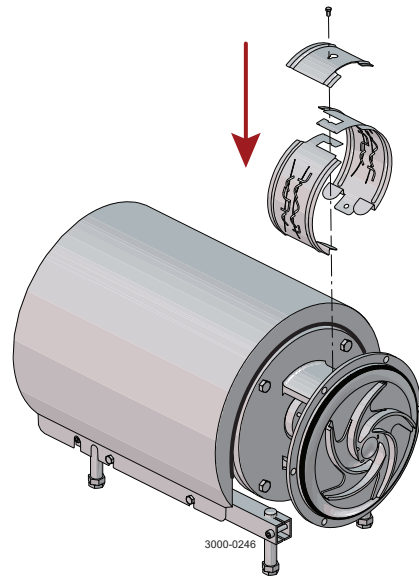

### Step 10

1. Fit pump casing (29).

2. Tighten nuts (20) for back plate (25).

3.

A. LKH-5: Fit clamps (55+55a), spring washers (56a) and screws (56) and tighten.

B. LKH-10 to -90: Fit washers (24a) and cap nuts (24) and tighten, according to torque values in chapter 6 Technical data.

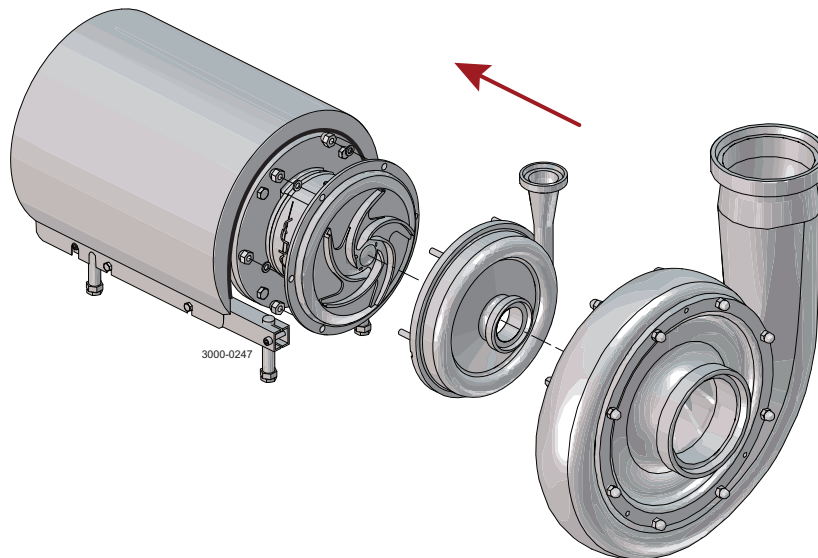

LKH-85 and LKH-90



Read the instructions carefully. The items refer to the parts list and service kits section.  
Lubricate the rubber seals before fitting them.  
\* : Relates to the shaft seal.

### 5.7 Adjustment of shaft (LKH-5)

#### Step 1

1. Loosen screws (6).
2. Pull off stub shaft (7).

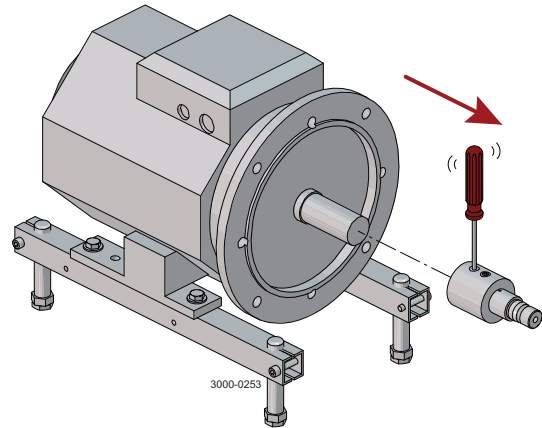

#### Step 2

1. Push stub shaft (7) onto the motor shaft. Screws (4) must fit in the keyway on the motor shaft.
2. Check that the clearance between the end of the stub shaft and the motor flange is 10-20 mm (0.39 - 0.78 inch).

\*) 10-20 mm (0.39-0.78 inch)

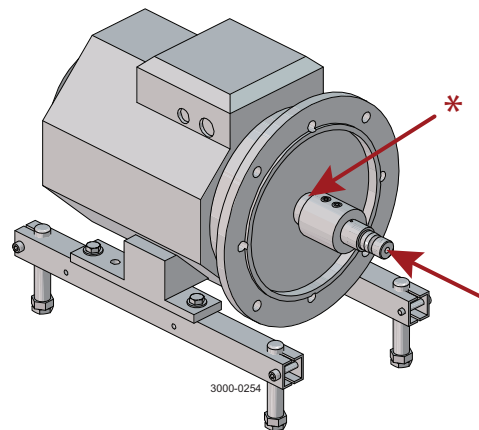

#### Step 3

1. Tighten screws (4) lightly and evenly.
2. Ensure that stub shaft (7) can be moved on the motor shaft.

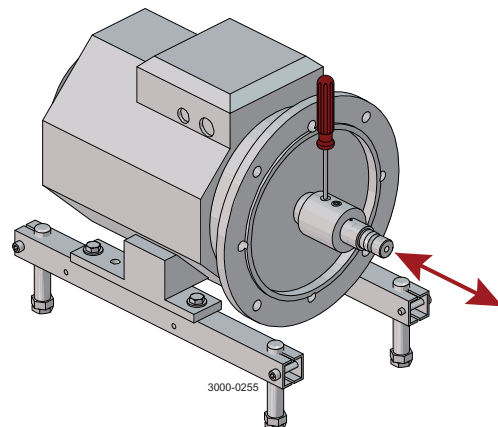

## 5 Maintenance

Read the instructions carefully. The items refer to the parts list and service kits section.

Lubricate the rubber seals before fitting them.

\* : Relates to the shaft seal.

### Step 4

1. **For the double mechanical shaft seal:** Fit drive ring (52) on stub shaft (7).
2. Fit back plate (25), washers (21) and nuts (20) and tighten.

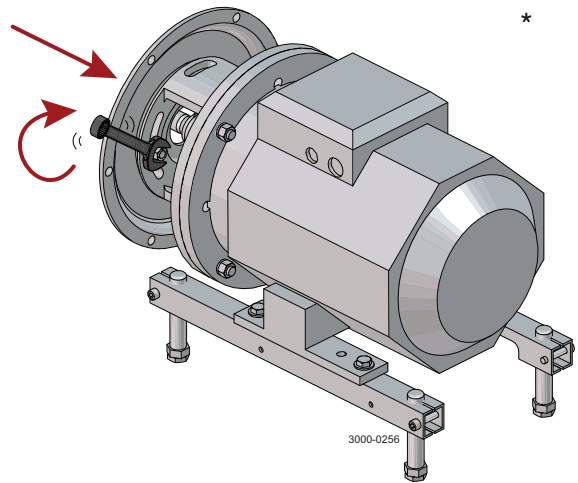

### Step 5

1. Fit impeller (27) on stub shaft (7).
2. Ensure that the clearance between the impeller and back plate (25) is correct: 0.5 mm (0.02 inch) for LKH-5.

The clearance can be adjusted by knocking gently with a plastic hammer.

\*) LKH-5 = 0.5 mm (0.02 inch)

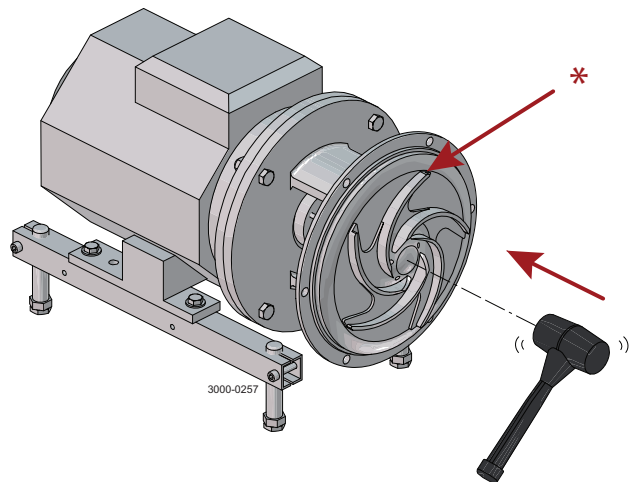

### Step 6

Tighten screws (4) evenly to 15 Nm (11 lbf-ft).

Tighten screws diagonally.

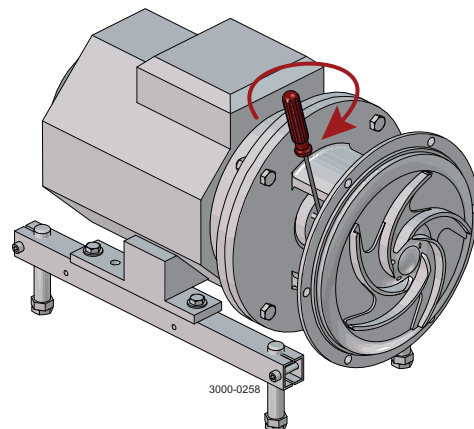

Read the instructions carefully. The items refer to the parts list and service kits section.

Lubricate the rubber seals before fitting them.

\* : Relates to the shaft seal.

### 5.8 Adjustment of shaft (LKH-10 to -90)

#### LKH-70 to -90

For securing the best fixture to the motor shaft ensure the following:

- Conical surfaces on the pump shaft and compression rings are applied with grease.
- No grease on the motor shaft.
- No grease on the inside diameter of the pump shaft.
- Screws for the compression rings are applied with grease.

#### Step 1

1. Loosen screws (6).
2. Pull off stub shaft (7) together with compression rings (5a, 5b).

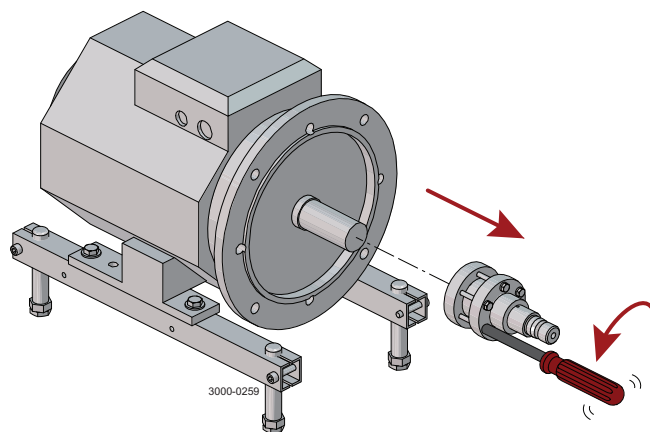

#### Step 2

1. Push stub shaft (7) together with compression rings (5a, 5b) onto the motor shaft.
2. Check that the clearance between the end of the stub shaft and the motor flange is 10-20 mm (0.39 - 0.78 inch).

\*) 10-20 mm (0.39-0.78 inch)

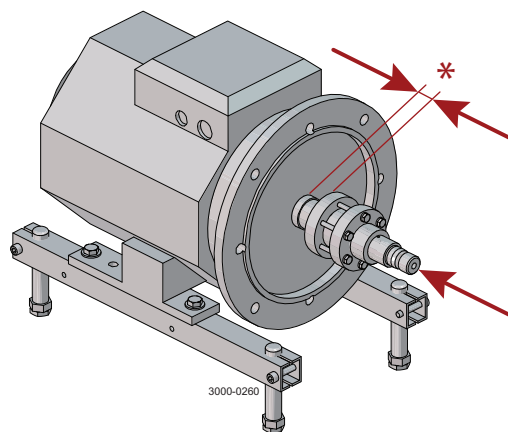

#### Step 3

1. Tighten screws (6) lightly and evenly.
2. Ensure that stub shaft (7) can be moved on the motor shaft.

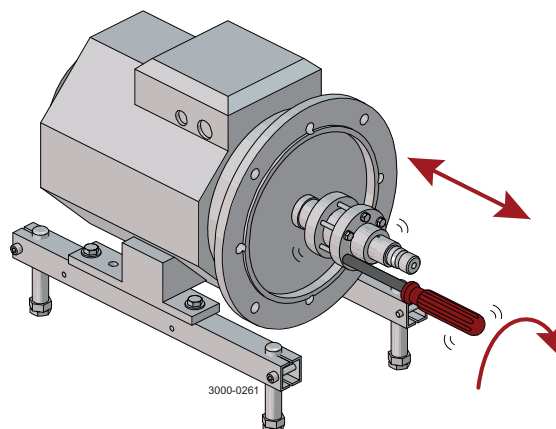

## 5 Maintenance

Read the instructions carefully. The items refer to the parts list and service kits section.  
Lubricate the rubber seals before fitting them.

\* : Relates to the shaft seal.

### Step 4

1. For the double mechanical shaft seal:  
Fit drive ring (52) on stub shaft (7).
2. Fit back plate (25), washers (21) and nuts (20) and tighten.

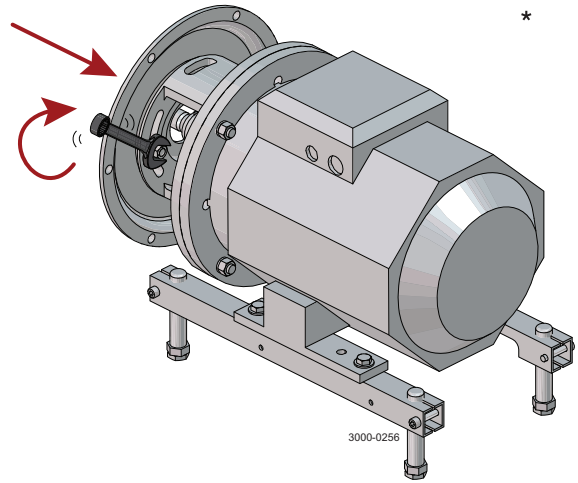

### Step 5

1. Fit impeller (27) on stub shaft (7).
2. Ensure that the clearance between the impeller and back plate (25) is correct: 0.5 mm (0.02 inch) for LKH-10 to -60 and 1.0 mm (0.039 inch) for LKH-70 to -90.
3. Tighten screws (6) evenly until the stub shaft (7) cannot move on the motor shaft.

The clearance can be adjusted by knocking gently with a plastic hammer.

\*) LKH-10 to -60 = 0.5 mm (0.02 inch)  
LKH-70 to -90 = 1.0 mm (0.039 inch)

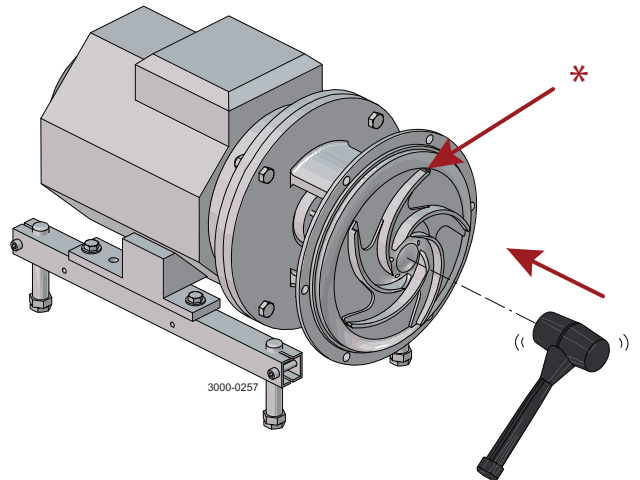

### Step 6

1. Remove impeller (27), back plate (25) and drive ring (52).
2. Tighten screws (6) evenly to 15 Nm (11 lbf-ft).

Tighten screws diagonally.

\*) 15Nm (11 lbf-ft)

Counterhold with a screwdriver

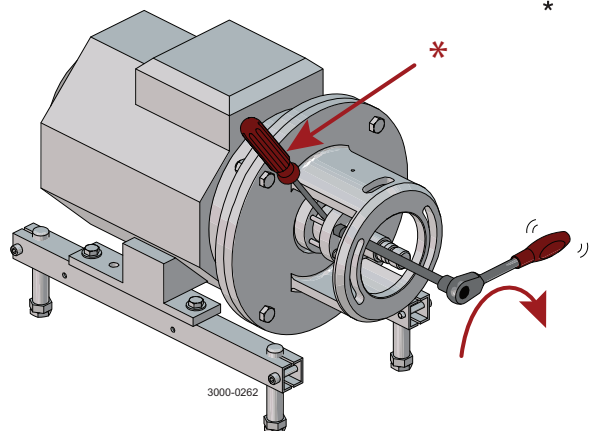

## 6 Technical data

It is important to observe the technical data during installation, operation and maintenance.  
Inform personnel about the technical data.

### 6.1 Technical data

The LKH pump is a highly efficient and economical centrifugal pump, which meets the requirements of sanitary and gentle product treatment and chemical resistance. LKH is available in the following sizes LKH-5, -10, -15, -20, -25, -35, -40, -50, -60, -70, -75, -85 and -90. The instruction manual is part of the delivery. Read the instructions carefully. The large pump sizes are very heavy. Alfa Laval therefore recommends the use of a lifting crane when handling the pump.

Data																					
Max. inlet pressure *	<table border="0"> <tr> <td>LKH-5 :</td> <td>600 kPa</td> <td>(6 bar)</td> <td>(87 psi)</td> </tr> <tr> <td>LKH-10 to -70 (50 Hz):</td> <td>1000 kPa</td> <td>(10 bar)</td> <td>(145 psi)</td> </tr> <tr> <td>LKH-85 and LKH-90 (50 Hz):</td> <td>500 kPa</td> <td>(5 bar)</td> <td>(72.5 psi)</td> </tr> <tr> <td>LKH-10 to -60 (60 Hz):</td> <td>1000 kPa</td> <td>(10 bar)</td> <td>(145 psi)</td> </tr> <tr> <td>LKH-70, LKH-75, LKH-85, LKH-90 (60 Hz):</td> <td>500 kPa</td> <td>(5 bar)</td> <td>(72.5 psi)</td> </tr> </table>	LKH-5 :	600 kPa	(6 bar)	(87 psi)	LKH-10 to -70 (50 Hz):	1000 kPa	(10 bar)	(145 psi)	LKH-85 and LKH-90 (50 Hz):	500 kPa	(5 bar)	(72.5 psi)	LKH-10 to -60 (60 Hz):	1000 kPa	(10 bar)	(145 psi)	LKH-70, LKH-75, LKH-85, LKH-90 (60 Hz):	500 kPa	(5 bar)	(72.5 psi)
LKH-5 :	600 kPa	(6 bar)	(87 psi)																		
LKH-10 to -70 (50 Hz):	1000 kPa	(10 bar)	(145 psi)																		
LKH-85 and LKH-90 (50 Hz):	500 kPa	(5 bar)	(72.5 psi)																		
LKH-10 to -60 (60 Hz):	1000 kPa	(10 bar)	(145 psi)																		
LKH-70, LKH-75, LKH-85, LKH-90 (60 Hz):	500 kPa	(5 bar)	(72.5 psi)																		
Temperature range	-10°C to +140°C (EPDM) (14 to 284°F)																				
Max. speed:	<table border="0"> <tr> <td>2 poles: 0,75 - 45 kW</td> <td>900 - 4000 rpm</td> </tr> <tr> <td>2 poles: 55 - 110 kW</td> <td>900 - 3600 rpm</td> </tr> <tr> <td>4 poles: 0,75 - 75 kW</td> <td>900 - 2200 rpm</td> </tr> </table>	2 poles: 0,75 - 45 kW	900 - 4000 rpm	2 poles: 55 - 110 kW	900 - 3600 rpm	4 poles: 0,75 - 75 kW	900 - 2200 rpm														
2 poles: 0,75 - 45 kW	900 - 4000 rpm																				
2 poles: 55 - 110 kW	900 - 3600 rpm																				
4 poles: 0,75 - 75 kW	900 - 2200 rpm																				
Maximum product viscosity:	800 cP																				
Materials																					
Product wetted steel parts	AISI 316L																				
Other steel parts	Stainless steel																				
Product wetted seals	EPDM (standard)																				
Other O-rings	EPDM (standard)																				
Alternative seals	Nitrile (NBR), fluorinated rubber (FPM) and FEP																				
Shaft seal																					
Seal types	External single, flushed or double mechanical seal																				
Max. temperature flush media	70°C <b>NOTE:</b> When the pump is not in operation the flush housing can be sterilized up to 125°C																				
Max. water pressure (flushed seal)	Normally atmospheric (max. 1 bar) (max. 14.5 psi)																				
Water consumption (flushed seal)	0.25 - 0.5 l/min. (0.07-0.13 gl)																				
Max. water pressure LKH-5 to -60 (DMS)	Normally atmospheric (max. 5 bar) (max. 72.5 psi)																				
Max. water pressure LKH-70 to -90 (DMS)	Normally atmospheric (max. 3 bar) (max. 43.5 psi)																				
Water consumption (double mechanical seal)	0.25-0.5 l/min. (0.07-0.13 gl)																				
Material, stationary seal ring	Acid-resistant steel with sealing surface of silicon carbide																				
Material, rotating seal ring	Carbon (standard) or silicon carbide																				
Material, O-rings	EPDM (standard)																				
Alternative material, O-rings	Nitrile (NBR), fluorinated rubber (FPM) and FEP																				
Motor																					
Foot-flanged motor according to IEC metric standard, 2 poles = 3000/3600 rpm. at 50/60 Hz IP55, insulation class F																					
Motor sizes (kW), 50 Hz	0.75 - 110 kW																				
Motor sizes (kW), 60 Hz	0.9 - 110 kW																				
Motor sizes (Hp), 60 Hz	1.5 - 150 Hp																				

For further information, see PD sheet.

\* Max 5 bar (72psi) inlet pressure allowed if the pump is mounted on an explosion proof motor Exd or Exde, type WEG W21.



## 6 Technical data

It is important to observe the technical data during installation, operation and maintenance.  
Inform personnel about the technical data.

### 6.2 Relubrication intervals

For recommended grease types and general maintenance follow the recommendations in the motor instruction manual.

For relubrication intervals see motor name plate.

For further information contact your local Alfa Laval Technical Support.

**Warning: Polyurea based grease (used on eg. LKH85 motors) must not be mixed with Lithium based grease or vice versa.**

### 6.3 Torque Specifications

The table below specifies the tightening torques for the screws, bolts and nuts in this pump.

Always use the torques specified below if no other values are stated. This can be a matter of personal safety.

Size	Tightening torque	
	Nm	lbf-ft
M8	20	15
M10	40	30
M12	67	49
M14	110	81

### 6.4 Weight (kg)

Pump Type: LKH

Size	80		90		100		112		132		Motor 160		180		200		250		280	
	0.75kW	1.1kW	1.5kW	2.2kW	3kW	4kW	5.5kW	7.5kW	11kW	15kW	18.5kW	22kW	30kW	37kW	45kW	55kW	75kW	90kW	110kW	
5	42	42	49	51	70	75														
10			53	55	70	75														
15					73	78	95													
20			55	57	72	77	94	108												
25						81	98	112	171	185										
35						81	98	112	171	185										
40								115	174	188	206	225								
45						82	99	113	172	186										
50							101	115	174	188	206	225								
60							102	116	175	189	207	226	334							
70							138	152	196	210	228	259	365	380	396	522	557			
85													417	432	448	574	609	889	949	
90													430	445	461	587	622			

Weight can vary depending of configuration. Weight is only to be seen as a reference value during handling, transporting and packaging.



CSI

CONTACT CSI FOR MORE INFORMATION | CSIDESIGNS.COM | SALES@CSIDESIGNS.COM | 417.831.1411

*It is important to observe the technical data during installation, operation and maintenance.  
Inform personnel about the technical data.*

## 6.5 Noise emission

Pump Type	Sound pressure level (dBA)
LKH-5	60
LKH-10	69
LKH-15	72
LKH-20	70
LKH-25	74
LKH-35	71
LKH-40	75
LKH-45	70
LKH-50	75
LKH-60	77
LKH-70	88
LKH-75	79
LKH-85	86
LKH-90	75
LKH-112	70
LKH-113	69
LKH-114	68
LKH-122	75
LKH-123	77
LKH-124	80
SolidC-1	68
SolidC-2	72
SolidC-3	73
SolidC-4	72
MR-166	76
MR-185	82
MR-200	81
MR-300	82
GM	54
FM-OS	61

The above LKH noise levels are the same for LKHFP, LKHI, LKH UltraPure, LKH Evap and LKHex.  
The above SolidC noise levels are the same for SolidC UltraPure.

The noise measurements have been carried out using the original motor and shroud, at the approximate Best Efficiency Point (BEP) with water at ambient temperature and at 50 Hz.

Very often, the noise level generated by the flow through the process system (e.g. valves, pipes, tanks etc.) is much higher than what generated by the pump itself. Therefore, it is important to consider the noise level from the total system and take the necessary precautions with regard to personal safety if required.



## 7 Parts list and service kits

The drawing shows LKH pump, sanitary version.

### 7.1 LKH-5 Sanitary version

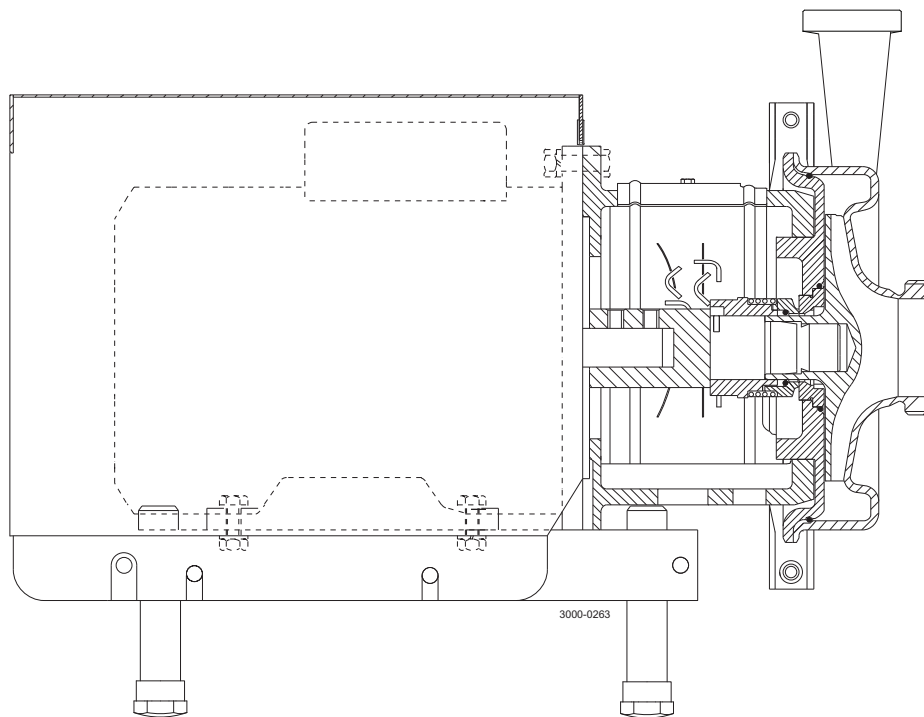

US legs are different to the ones shown. For further information see US spare parts.

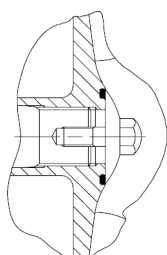

Impeller screw

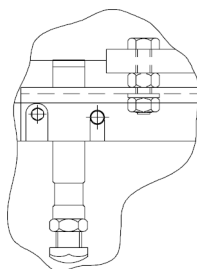

Fitting of legs  
0.75-1.1 kW

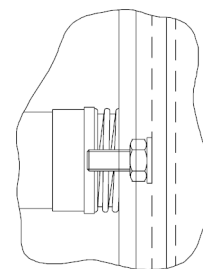

Fitting of back plate

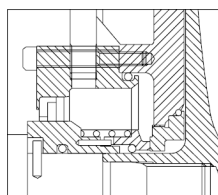

Flushed shaft seal

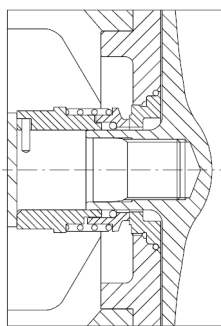

Single shaft seat

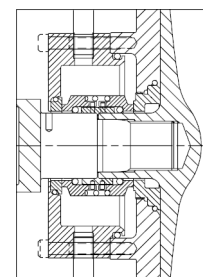

Double mechanical shaft seal



CSI

CONTACT CSI FOR MORE INFORMATION | [CSIDESIGNS.COM](http://CSIDESIGNS.COM) | [SALES@CSIDESIGNS.COM](mailto:SALES@CSIDESIGNS.COM) | 417.831.1411



The drawing shows the LKH pump, sanitary version.

## 7.2 LKH-10, -15, -20, -25, -35, -40, -50, -60, -70, -75, -85, -90 sanitary version

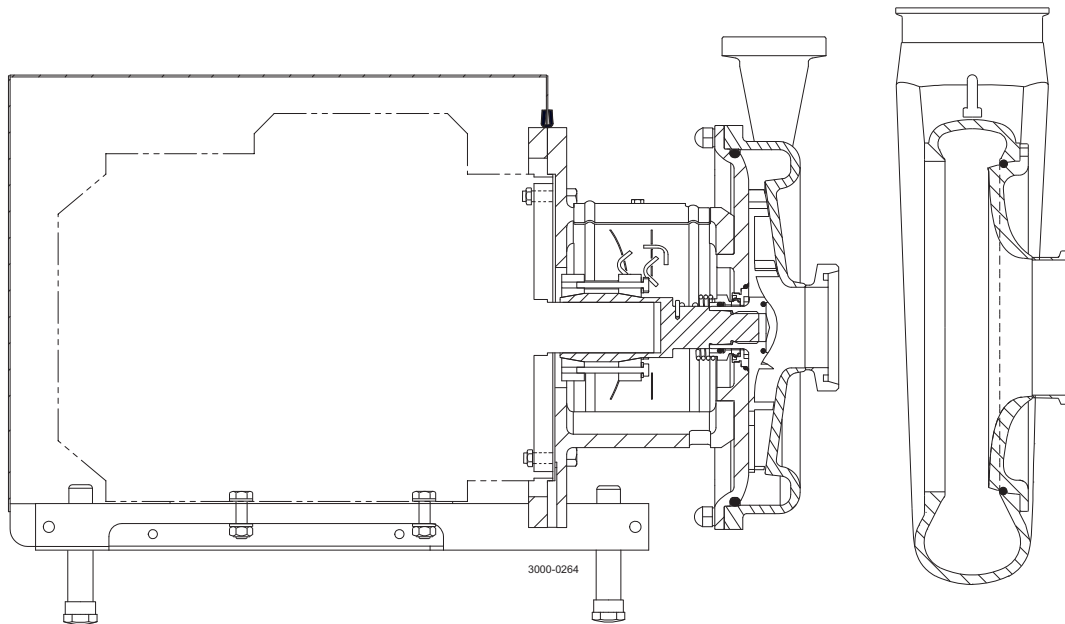

LKH10 -75

LKH-85 and LKH-90

US legs are different to the ones shown. For further information see US spare parts.

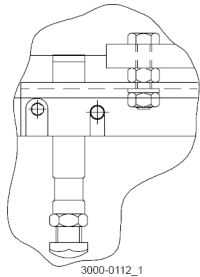

Only used for 0.75, 1.1 and 3 kW  
Fitting of legs

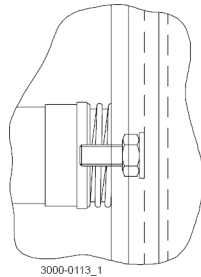

Fitting of back plate

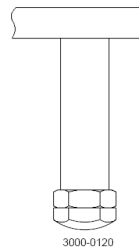

Only used for 55 - 110 kW  
Fitting of legs

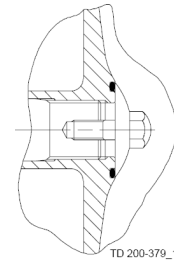

Impeller screw

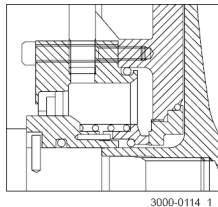

Flushed shaft seal

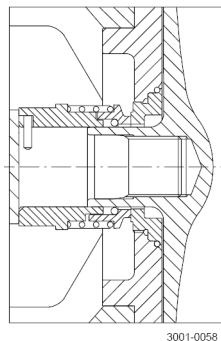

Single shaft seal

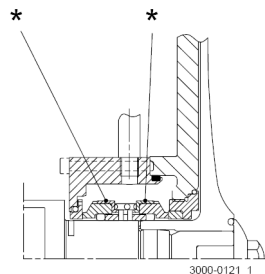

Double mechanical shaft seal  
\* Only used for LKH-70, -75, -85, -90

# 7 Parts list and service kits

The drawing shows the LKH pump, sanitary version.

## 7.3 LKH - Product wetted parts

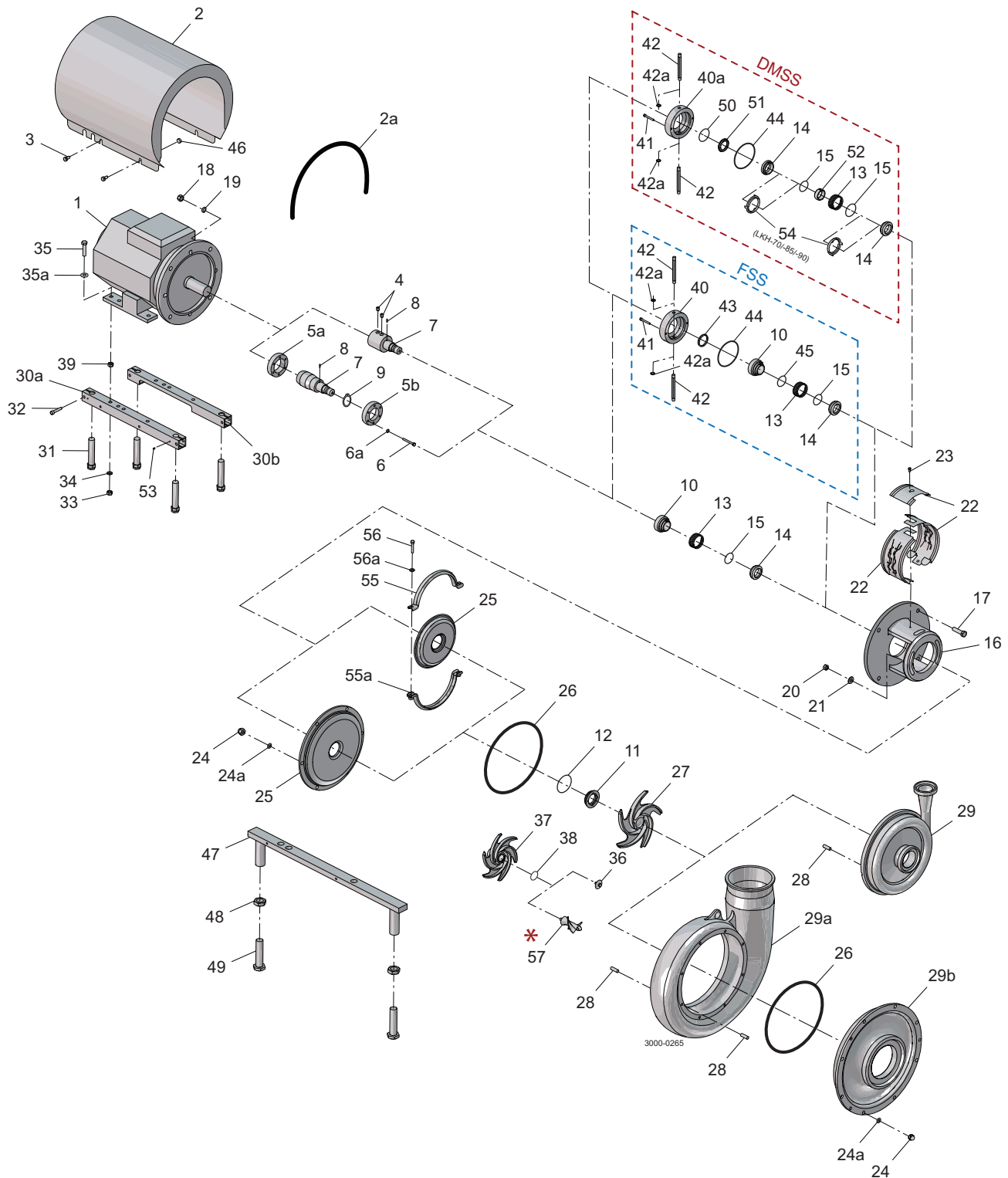

\* If inducer (57) is retrofitted. Pump inlet may have to be slightly ground.



CSI

CONTACT CSI FOR MORE INFORMATION | CSIDESIGNS.COM | SALES@CSIDESIGNS.COM | 417.831.1411

## 7 Parts list and service kits

The drawing shows the LKH pump, sanitary version.

### Parts list

Pos.	Qty	Denomination
20	2	Nut
21	2	Washer
24	6	Cap nut
24a	6	Washer
25	1	Back plate
26	1	O-ring
27	1	Impeller
28	6	Bolt
29	1	IDF Malepart
36	1	Impeller screw
37	1	Impeller for impeller screw
38	1	O-ring
55	1	Upper clamp
55a	1	Lower clamp
56	2	Screw
56a	2	Spring washer
57 *	1	Inducer

# 7 Parts list and service kits

The drawing shows the LKH pump, sanitary version.

## 7.4 LKH - Motor-dependent parts

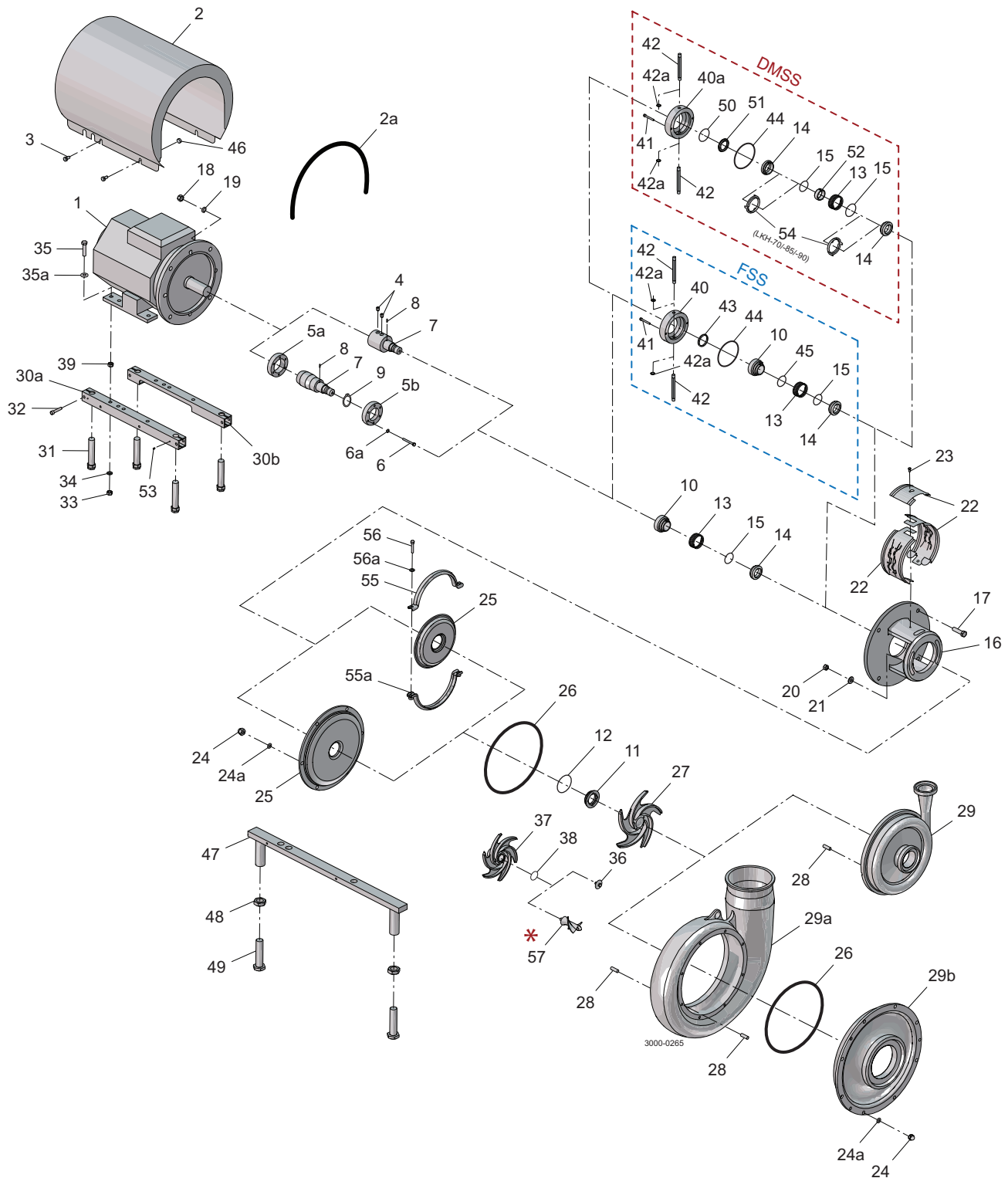

\* If inducer (57) is retrofitted. Pump inlet may have to be slightly ground.



CSI

CONTACT CSI FOR MORE INFORMATION | CSIDESIGNS.COM | SALES@CSIDESIGNS.COM | 417.831.1411

## 7 Parts list and service kits

The drawing shows the LKH pump, sanitary version.

### Parts list

Pos.	Qty	Denomination
1	1	Motor ABB
	1	Motor ABB
2	1	Shroud
3	4	Screw
4	2	Screw
5a	1	Compression ring with thread
5b	1	Compression ring without thread
6	6	Screw
6a	6	Washer
7	1	Shaft incl. pin
8	1	Connex pin
9	1	Retaining ring
16	1	Adaptor
17	4	Screw for adaptor
18	4	Nut for adaptor
19	4	Washer for adaptor
22	1	Safety guard set
23	1	Screw for safety guard
30a	1	Support bar, right
30b	1	Support bar, left
31	4	Leg
32	4	Screw
33	4	Nut
34	4	Spring washer
35	4	Screw
35a	4	Washer
39	4	Nut
46	4	Distance sleeve
	4	Distance sleeve
47	2	Leg bracket
48	4	Nut for leg
49	4	Screw for leg
53	4	Pivot screw

# 7 Parts list and service kits

The drawing shows the LKH pump, sanitary version.

## 7.5 LKH - Shaft seal

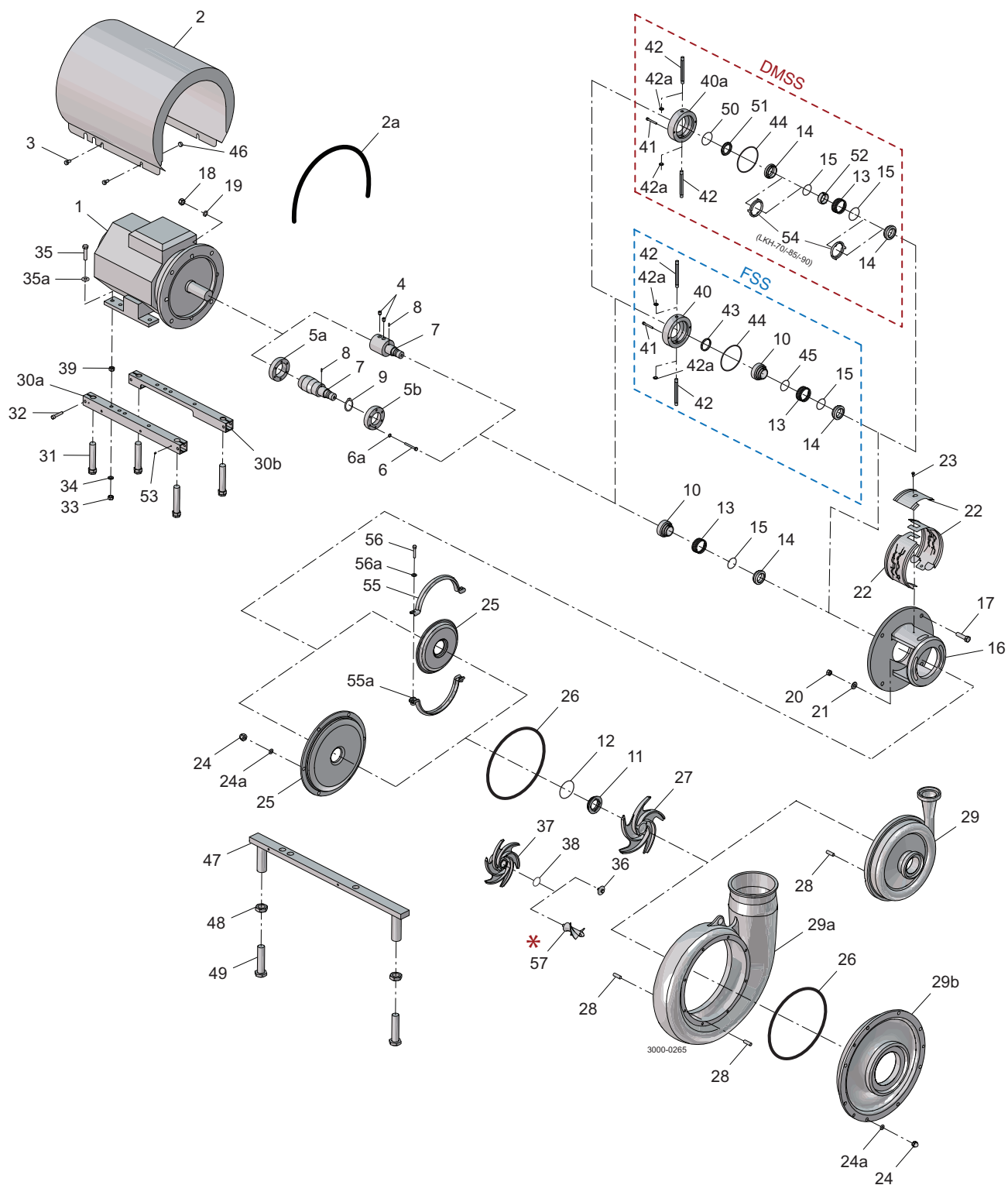

\* If inducer (57) is retrofitted. Pump inlet may have to be slightly ground.



CSI

CONTACT CSI FOR MORE INFORMATION | CSIDESIGNS.COM | SALES@CSIDESIGNS.COM | 417.831.1411

## 7 Parts list and service kits

The drawing shows the LKH pump, sanitary version.

### Parts list

Pos.	Qty	Denomination
10	1	Drive ring
11	1	Stationary seal ring
12	1	O-ring
13	1	Spring
14	1	Rotating seal ring
15	1	O-ring
40	1	Seal housing
40a	1	Seal housing
41	2	Screw for seal housing
42	2	Tube
42a	2	Fitting
43	1	Lip seal
44	1	O-ring for seal housing
45	1	O-ring for drive ring
50	1	O-ring
51	1	Sec. stationary seal ring
52	1	Drive ring
54	2	Cup

### Service kits

Denomination	EPDM	NBR	FPM	FEP
<b>Service kit for single shaft seal C/SiC</b>				
□ Service kit, C/SiC (LKH-5) .....	9611922302	9611922303	9611922304	9611922305
□ Service kit, C/SiC (LKH-10/15) .....	9611922072	9611922073	9611922074	9611922075
□ Service kit, C/SiC (LKH-20) .....	9611922080	9611922081	9611922082	9611922083
□ Service kit, C/SiC (LKH-25/35/45) .....	9611922178	9611922179	9611922180	9611922181
□ Service kit, C/SiC (LKH-40/50/60) .....	9611922088	9611922089	9611922090	9611922091
<b>Service kit for single shaft seal SiC/SiC</b>				
✦ Service kit, SiC/SiC (LKH-5) .....	9611922522	9611922523	9611922524	9611922525
✦ Service kit, SiC/SiC (LKH-10/15) .....	9611922546	9611922547	9611922548	9611922549
✦ Service kit, SiC/SiC (LKH-20) .....	9611922570	9611922571	9611922572	9611922573
✦ Service kit, SiC/SiC (LKH-25/35/45) .....	9611922594	9611922595	9611922596	9611922597
✦ Service kit, SiC/SiC (LKH-40/50/60) .....	9611922619	9611922620	9611922621	9611922622
<b>Service kit for single shaft seal and impeller screw C/SiC</b>				
♦ Service kit, C/SiC (LKH-5) .....	9611922306	9611922307	9611922308	9611922309
♦ Service kit, C/SiC (LKH-10/15) .....	9611922114	9611922115	9611922116	9611922117
♦ Service kit, C/SiC (LKH-20) .....	9611922122	9611922123	9611922124	9611922125
♦ Service kit, C/SiC (LKH-25/35/45) .....	9611922182	9611922183	9611922184	9611922185
♦ Service kit, C/SiC (LKH-40/50/60) .....	9611922130	9611922131	9611922132	9611922133
♦ Service kit, C/SiC (LKH-70) .....	9611922238	9611922239	9611922240	9611922241
♦ Service kit, C/SiC (LKH-85) .....	9611922952	9611922953	9611922954	9611922955
♦ Service kit, C/SiC (LKH-90) .....	9611922867	9611922868	9611922869	9611922870
<b>Service kit for single shaft seal and impeller screw SiC/SiC</b>				
✦ Service kit, SiC/SiC (LKH-5) .....	9611922526	9611922527	9611922528	9611922529
✦ Service kit, SiC/SiC (LKH-10/15) .....	9611922550	9611922551	9611922552	9611922553
✦ Service kit, SiC/SiC (LKH-20) .....	9611922574	9611922575	9611922576	9611922577
✦ Service kit, SiC/SiC (LKH-25/35/45) .....	9611922598	9611922599	9611922600	9611922601
✦ Service kit, SiC/SiC (LKH-40/50/60) .....	9611922623	9611922624	9611922625	9611922626



CSI

CONTACT CSI FOR MORE INFORMATION | CSIDESIGNS.COM | SALES@CSIDESIGNS.COM | 417.831.1411

## 7 Parts list and service kits

The drawing shows the LKH pump, sanitary version.

Denomination	EPDM	NBR	FPM	FEP
◇ Service kit, SiC/SiC (LKH-70) .....	9611922643	9611922644	9611922645	9611922646
◇ Service kit, SiC/SiC (LKH-85) .....	9611922964	9611922965	9611922966	9611922967
◇ Service kit, SiC/SiC (LKH-90) .....	9611922879	9611922880	9611922881	9611922882

### Service kit for flushed shaft seal C/SiC

○ Service kit, C/SiC (LKH-5) .....	9611922310	9611922311	9611922312	9611922313
○ Service kit, C/SiC (LKH-10/15) .....	9611922076	9611922077	9611922078	9611922079
○ Service kit, C/SiC (LKH-20) .....	9611922084	9611922085	9611922086	9611922087
○ Service kit, C/SiC (LKH-25/35/45) .....	9611922186	9611922187	9611922188	9611922189
○ Service kit, C/SiC (LKH-40/50/60) .....	9611922092	9611922093	9611922094	9611922095

### Service kit for flushed shaft seal SiC/SiC

■ Service kit, SiC/SiC (LKH-5) .....	9611922530	9611922531	9611922532	9611922533
■ Service kit, SiC/SiC (LKH-10/15) .....	9611922554	9611922555	9611922556	9611922557
■ Service kit, SiC/SiC (LKH-20) .....	9611922578	9611922579	9611922580	9611922581
■ Service kit, SiC/SiC (LKH-25/35/45) .....	9611922602	9611922603	9611922604	9611922605
■ Service kit, SiC/SiC (LKH-40/50/60) .....	9611922627	9611922628	9611922629	9611922630

### Service kits

Denomination	EPDM	NBR	FPM	FEP
Service kit for flushed shaft seal and impeller screw C/SiC				
* Service kit, C/SiC (LKH-5) .....	9611922314	9611922315	9611922316	9611922317
* Service kit, C/SiC (LKH-10/15) .....	9611922118	9611922119	9611922120	9611922121
* Service kit, C/SiC (LKH-20) .....	9611922126	9611922127	9611922128	9611922129
* Service kit, C/SiC (LKH-25/35/45) .....	9611922190	9611922191	9611922192	9611922193
* Service kit, C/SiC (LKH-40/50/60) .....	9611922134	9611922135	9611922136	9611922137
* Service kit, C/SiC (LKH-70) .....	9611922242	9611922243	9611922244	9611922245
* Service kit, C/SiC (LKH-85) .....	9611922956	9611922957	9611922958	9611922959
* Service kit, C/SiC (LKH-90) .....	9611922871	9611922872	9611922873	9611922874

### Service kit for flushed shaft seal and impeller screw SiC/SiC

◇ Service kit, SiC/SiC (LKH-5) .....	9611922534	9611922535	9611922536	9611922537
◇ Service kit, SiC/SiC (LKH-10/15) .....	9611922558	9611922559	9611922560	9611922561
◇ Service kit, SiC/SiC (LKH-20) .....	9611922582	9611922583	9611922584	9611922585
◇ Service kit, SiC/SiC (LKH-25/35/45) .....	9611922606	9611922607	9611922608	9611922609
◇ Service kit, SiC/SiC (LKH-40/50/60) .....	9611922631	9611922632	9611922633	9611922634
◇ Service kit, SiC/SiC (LKH-70) .....	9611922647	9611922648	9611922649	9611922650
◇ Service kit, SiC/SiC (LKH-85) .....	9611922968	9611922969	9611922970	9611922971
◇ Service kit, SiC/SiC (LKH-90) .....	9611922883	9611922884	9611922885	9611922886

### Service kit for double mechanical shaft seal C/SiC

△ Service kit, C/SiC (LKH-5) .....	9611922318	9611922319	9611922320	9611922321
△ Service kit, C/SiC (LKH-10/15) .....	9611922206	9611922207	9611922208	9611922209
△ Service kit, C/SiC (LKH-20) .....	9611922214	9611922215	9611922216	9611922217
△ Service kit, C/SiC (LKH-25/35/45) .....	9611922222	9611922223	9611922224	9611922225
△ Service kit, C/SiC (LKH-40/50/60) .....	9611922230	9611922231	9611922232	9611922233

### Service kit for double mechanical shaft seal SiC/SiC

⊗ Service kit, SiC/SiC (LKH-5) .....	9611922538	9611922539	9611922540	9611922541
--------------------------------------	------------	------------	------------	------------



CSI

CONTACT CSI FOR MORE INFORMATION | CSIDESIGNS.COM | SALES@CSIDESIGNS.COM | 417.831.1411



## 7 Parts list and service kits

The drawing shows the LKH pump, sanitary version.

⌘	Service kit, SiC/SiC (LKH-10/15) .....	9611922562	9611922563	9611922564	9611922565
⌘	Service kit, SiC/SiC (LKH-20) .....	9611922586	9611922587	9611922588	9611922589
⌘	Service kit, SiC/SiC (LKH-25/35/45) .....	9611922610	9611922611	9611922612	9611922613
⌘	Service kit, SiC/SiC (LKH-40/50/60) .....	9611922635	9611922636	9611922637	9611922638

### Service kit for double mechanical shaft seal and impeller screw C/SiC

▲	Service kit, C/SiC (LKH-5) .....	9611922322	9611922323	9611922324	9611922325
▲	Service kit, C/SiC (LKH-10/15) .....	9611922210	9611922211	9611922212	9611922213
▲	Service kit, C/SiC (LKH-20) .....	9611922218	9611922219	9611922220	9611922221
▲	Service kit, C/SiC (LKH-25/35/45) .....	9611922226	9611922227	9611922228	9611922229
▲	Service kit, C/SiC (LKH-40/50/60) .....	9611922234	9611922235	9611922236	9611922237
▲	Service kit, C/SiC (LKH-70) .....	9611922416	9611922417	9611922418	9611922419
▲	Service kit, C/SiC (LKH-85) .....	9611922960	9611922961	9611922962	9611922963
▲	Service kit, C/SiC (LKH-90) .....	9611922875	9611922876	9611922877	9611922878

### Service kit for double mechanical shaft seal and impeller screw SiC/SiC

●	Service kit, SiC/SiC (LKH-5) .....	9611922542	9611922543	9611922544	9611922545
●	Service kit, SiC/SiC (LKH-10/15) .....	9611922566	9611922567	9611922568	9611922569
●	Service kit, SiC/SiC (LKH-20) .....	9611922590	9611922591	9611922592	9611922593
●	Service kit, SiC/SiC (LKH-25/35/45) .....	9611922614	9611922615	9611922616	9611922617
●	Service kit, SiC/SiC (LKH-40/50/60) .....	9611922639	9611922640	9611922641	9611922642
●	Service kit, SiC/SiC (LKH-70) .....	9611922651	9611922652	9611922653	9611922654
●	Service kit, SiC/SiC (LKH-85) .....	9611922972	9611922973	9611922974	9611922975
●	Service kit, SiC/SiC (LKH-90) .....	9611922887	9611922888	9611922889	9611922890

Parts marked with □♦○★▲◆◇■⌘● are included in the service kits. Recommended spare parts: Service kits. (900601/9)

Conversion kit - single to double mechanical shaft seal: Please order double mechanical service kit + pos. 40a+41+42 (for LKH-85 pos

40a+41+42a). Conversion kit single to flushed shaft seal: Please order Flushed service kit + pos. 10+40+41+42 (for LKH85 pos.10+ 40+41+42a).

Replace to inducer (for pump with impeller screw). Please order pos. 7+57+38. Replace inducer (for pump without impeller screw) please

order pos. 7+57+37+38.



CSI

CONTACT CSI FOR MORE INFORMATION | CSIDESIGNS.COM | SALES@CSIDESIGNS.COM | 417.831.1411



**CSI**

CONTACT CSI FOR MORE INFORMATION | [CSIDESIGNS.COM](http://CSIDESIGNS.COM) | [SALES@CSIDESIGNS.COM](mailto:SALES@CSIDESIGNS.COM) | 417.831.1411



**CSI**

CONTACT CSI FOR MORE INFORMATION | [CSIDESIGNS.COM](http://CSIDESIGNS.COM) | [SALES@CSIDESIGNS.COM](mailto:SALES@CSIDESIGNS.COM) | 417.831.1411

#### **How to contact Alfa Laval**

Contact details for all countries are continually updated on our website.

Please visit [www.alfalaval.com](http://www.alfalaval.com) to access the information directly.

© 1999-02 Alfa Laval Corporate AB

This document and its contents is owned by Alfa Laval Corporate AB and protected by laws governing intellectual property and thereto related rights. It is the responsibility of the user of this document to comply with all applicable intellectual property laws. Without limiting any rights related to this document, no part of this document may be copied, reproduced or transmitted in any form or by any means (electronic, mechanical, photocopying, recording, or otherwise), or for any purpose, without the expressed permission of Alfa Laval Corporate AB. Alfa Laval Corporate AB will enforce its rights related to this document to the fullest extent of the law, including the seeking of criminal prosecution.



**CSI**

CONTACT CSI FOR MORE INFORMATION | [CSIDESIGNS.COM](http://CSIDESIGNS.COM) | [SALES@CSIDESIGNS.COM](mailto:SALES@CSIDESIGNS.COM) | 417.831.1411