

Alfa Laval EnSaLine S

Agitators

Introduction

Applications

EnSaLine S is designed for a wide range of tank mixing and agitation duties across the dairy, food, beverage, brewery, personal care, biotechnology and pharmaceutical industries.

Duties	Typical examples
Keeping media homogeneous	Milk storage tanks, cream tanks, mixed products tanks, UHT, and product storage tanks
Mixing and solutions	Fluid mixing, drinking yoghurt and fruit mix tanks, flavoured milk mix tanks, and syrup mix tanks
Dispersing	Powder protein and oil mix tanks, micro salt and milk product mix tanks
Suspension	Fluids with particles, juice tanks, crystallizing tanks, etc.
Heat transmission	Circulation of media in tank with dimple jacket (cooling or heating)

Benefits

- Outstanding performance and gentle product treatment
- Easy and safe maintenance from outside the tank
- All seals and bearings in one replaceable cartridge
- Fully flushable design and hygienic seal housing for superior cleanability and product safety
- Prepared for industrial connectivity for condition monitoring
- Meets EU and US standards and regulations such as EHEDG, USDA, FDA and 3-A Sanitary Standards

Standard design

EnSaLine S consists of a drive unit with bearing frame, shaft with special cartridge shaft seal, and EnSaFoil™ impellers with two or three blades. Inside the tank, the fully flushable design with no mounting flange and the hygienic seal housing offer excellent cleanability. EnSaLine S agitators give rapid and tool-free access, enabling one technician to complete service in under 30 minutes. During maintenance, the shaft remains securely fixed and there is no need for the technician to enter the tank. Sealings and O-rings can be replaced from the outside. EnSaLine S is prepared for wireless condition monitoring.

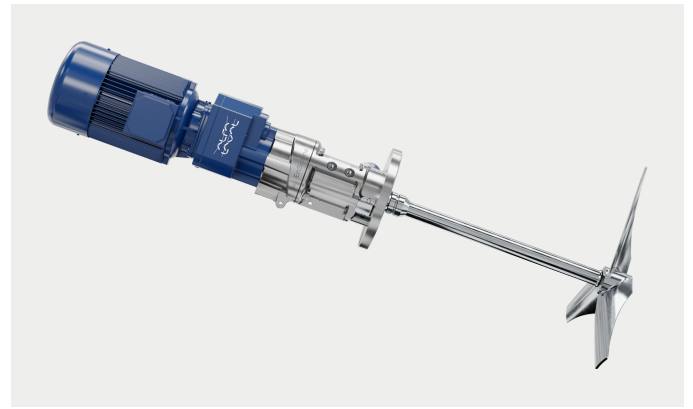

Working principle

Power from the motor – direct or via gearbox – drives the shaft, rotating impellers for optimal mixing and low energy consumption. The unique EnSaFoil™ two or three blade impellers generate strong axial flow with minimal shear, ensuring uniform mixing and blending. The high mixing efficiency cuts energy consumption by up to 80% and limits heat transfer to the product, lowering cooling requirements.

Options

- Pharma (UltraPure), Food or Industrial versions
- Welding flange (mandatory accessory) - also versions for upgrade of existing agitators
- Stainless steel shroud for gear motor
- Various surface treatments for gear motor according to DIN EN ISO 12944-2
- Various elastomer materials or shaft seal face combinations
- Special alloy on request
- Various documentation packages
- Condition monitor (accessory)
- Service tools for maintenance (available as a complete service suitcase including all tools necessary for doing service)
- Spare Part kits including complete cartridge spare unit for reduced downtime

Technical data

Gear motor

Gear and motor size and speed as required for duty:	High efficient premium gearbox
Motor efficiency class:	IE3 (standard) or IE4
IEC or NEMA motor, Ingress Protection:	IP55 (Standard) or IP66
Prepared for frequency converter duty:	Yes, with PTC
Painted RAL5010, according to DIN EN ISO 12944-2, corrosion class:	C2 (standard), C3, C4 or C5
Gear type:	Coaxial gear (standard)
Gear box oil type:	Synthetic Food Approved Oil (FDA 21CFR 178.3570, ISO 21469)
Stainless steel shroud (optional):	Available for coaxial gear motor types

Voltage and frequency

Will be configured for local voltage requirements. All motor voltages and frequencies are available.

Shaft housing

Housing size:	A30 or A45
Shaft size:	Ø30 or Ø45 mm / Ø1.18 or Ø1.77 inch
Coupling type (gear to shaft):	Flexible, spider type
Gear oil leak safety:	Oil trap with sight glass for detection

Shaft Seal Cartridge

Housing size:	A30 or A45
Shaft size:	Ø30 or Ø45 mm / Ø1.18 or Ø1.77 inch
Seal types:	Single Mechanical Seal (CWS) or Double Mechanical (CD)
Seal face combinations (depending on application):	CWS: SiC/SiC or C/SiC CD: SiC/SiC-C/SiC or C/SiC-C/SiC

Shaft

Shaft diameter:	Ø30 or Ø45 mm / Ø1.18 or Ø1.77 inch
Lengths:	A30: 500 mm / 19.69 inch A45: 700 mm / 27.56 inch

Impeller

Type:	Hydrofoil, EnSaFoil™
Size:	Ø125 to Ø1900 mm / Ø4.92 to Ø74.80 inch
Number of blades:	2 or 3
Thrust direction:	Away from drive (as standard)
Shaft connection:	Hygienic threaded connection with seal O-ring (can also be welded together during installation to avoid having any wear parts inside tank)

Surface finish, wetted parts

Industrial:	Brushed or Shot Peened: Ra < 3.2 µm / 126 µi
Hygienic (Food):	Polished: Ra < 0.8 µm / 32 µi
Hygienic (UltraPure):	Polished: Ra < 0.51 µm / 20 µi (ASME BPE SF1) or Electro polished: Ra < 0.38 µm / 15 µi (ASME BPE SF4)

Materials, wetted parts:

Steel parts:	AISI 316L (standard). Other materials on request
Seal rubber parts (O-rings):	EPDM or FKM or FFKM
Mechanical seal parts:	Carbon/Silicon Carbide or Silicon Carbide/Silicon Carbide

Materials, external parts:

Gear motor:	Aluminum (painted)
Steel parts:	AISI 304
Seal rubber parts (O-rings):	NBR

Welding flange (mandatory accessory)

Diameter/thickness:	A30: Ø250 mm/27 mm / 9.84 inch/1.06 inch A45: Ø300 mm/27 mm / Ø11.81 inch/1.06 inch
Approval:	Dual, PED and ASME
Certificate:	3.1 MTR, EN10204 (heat number marked on flange)

Certification and documentation

Certificate options:

2.2 Certificate and FDA (standard) or Alfa Laval Q-Doc Certificate Package

Q-Doc Certificate Package including: (For product contact parts PCPs):

- 3.1 Material Certificates according to EN10204 (MTR)
- FDA CFR 21 - Compliance with FDA CFR 21 (non-metallic parts), Title 21 Parts 170-199.
- USP or ISO 10993 - Compliance of Biocompatibility (non-metallic parts) – **NOTE:** Only UltraPure versions
- ADI - Compliance of non-Animal Derived Ingredient
- ASME BPE SF - Compliance of surface finish – **NOTE:** Only UltraPure versions
- EC No.: 1935/2004 - Compliance of traceability
- EC2023/2006 - Compliance of GMP for food contact materials and articles
- QMS - Compliance with Alfa Laval Quality Management System

Optional:

- Surface roughness measurements included
- Weld Log included
- Capillary liquid examination included
- Electro polishing certificate included

Certification:	3-A, 73-01 (optional, Hygienic versions)
----------------	--

Operating data**Operational tank pressure range:**

Single mechanical wet seal, type CWS:	-1 to 6 bar / -14.5 to 87 psi
Double mechanical flushed seal, CD:	-1 to 6 bar / -14.5 to 87 psi

Temperature

Operation temperature:	-10°C to 95°C / 14°F to 203°F (at higher temperatures consult Alfa Laval)
CIP temperature:	Max 95°C/203°F
SIP temperature:	Max 150°C/302°F
Flush, aseptic operation, double mechanical seal, CD:	Max 140°C/284°F

Service tools (accessories)

Service tool kit suitcase:	Size A30 or size A45 containing hinge jack, center jack, shaft retainers, wrench and hex key
Tools accessories:	A30 Supplementary kit for Service tool kit suitcase EnSaLine size A45 A45 Supplementary kit for Service tool kit suitcase EnSaLine size A30

Service tools:

- A: Center jack
B: Hinge jack
C: Shaft retainers

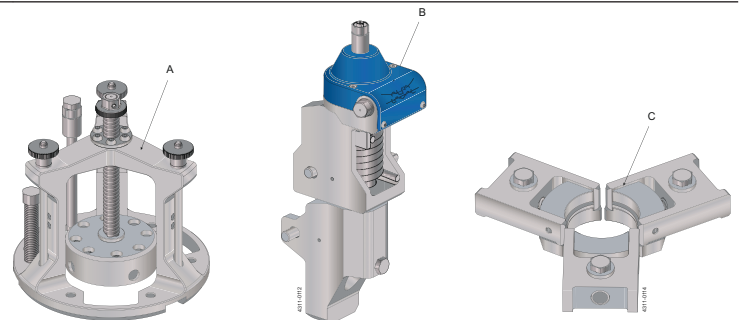

Dimensions

Propeller standard diameter range: Ø125 mm to Ø1900 mm / Ø4.92 inch to Ø74.8 inch.

The specific dimensions of the drive unit and propeller will vary depending on the selected configuration. Details regarding agitator dimensions and the required service space can be found in the Technical Specification for the selected agitator setup.

Agitator sizing

To properly size an agitator, certain essential information must be provided. Supplying the details listed below enables our Technical Support team to determine the optimal agitator configuration.

- Application/task of agitator
- Tank geometry
- Product properties
- Enquiry forms are available

Ordering

When placing an agitator order, please keep the following points in mind:

- A welding flange is required but not included with the agitator - please remember to order it separately
- Consider including service tools to support maintenance activities
- Consider ordering a complete cartridge spare unit to minimize downtime

This document and its contents are subject to copyrights and other intellectual property rights owned by Alfa Laval AB (publ) or any of its affiliates (jointly "Alfa Laval"). No part of this document may be copied, reproduced or transmitted in any form or by any means, or for any purpose, without Alfa Laval's prior express written permission. Information and services provided in this document are made as a benefit and service to the user, and no representations or warranties are made about the accuracy or suitability of this information and these services for any purpose. All rights are reserved.

How to contact Alfa Laval

Up-to-date Alfa Laval contact details for all countries are always available on our website at www.alfalaval.com