

Alfa Laval SMP-BC

Double seal valves

Introduction

The Alfa Laval SMP-BC Mixproof Valve is a hygienic pneumatic double-seal valve that safely handles the simultaneous flow of two different products through the same valve without any risk of cross-contamination. Standardized and cost-effective, the top-loaded valve is designed for quick leakage detection to maximize product safety and low maintenance due to few moving parts. It is often used in Cleaning-in-Place (CIP) lines and can also be used in other systems handling products.

Application

The Alfa Laval SMP-BC Mixproof Valve is designed for hygienic applications that require additional safety, leakage detection and CIP in the dairy, food and beverage, personal care and many other industries.

Benefits

- Hygienic double-seal mixproof valve
- Versatile, modular design meets most hygienic application requirements
- Cost effective

Working principle

The Alfa Laval SMP-BC Mixproof Valve is controlled by means of compressed air from a remote location. The valve is fitted with two small pneumatic normally open (NO) valves, a detecting valve and a CIP valve. The valve plug has two seals, which form an atmospheric leakage chamber. Any product leakage is discharged through the detecting valve. The leakage chamber may be cleaned by supplying a CIP system into the detecting valve. The SMP-BC is insensitive to water hammer in the product line above the plug.

Standard design

The Alfa Laval SMP-BC Mixproof Valve consists of valve bodies, bonnet, plug and an actuator. Two versions are available: a shut-off valve with one valve body and a shut-off valve with two valve bodies. A plug clip system and clamp rings secure the valve bodies to the actuator.

The valve can be fitted with Alfa Laval ThinkTop V-series for sensing and control of the valve. See ThinkTop datasheets for further details.



Technical data

Pressure

Max. product pressure (depending on valve specifications):	1000 kPa / 145 PSI (10 bar)
Min. product pressure:	Full vacuum
Air pressure:	500 to 800 kPa / 72.5 to 116 PSI (5 to 8 bar)

Temperature

Temperature range:	-10°C to +140°C / 14°F to +284°F (EPDM)
--------------------	---

ATEX

Classification:	II 2 G D ¹
-----------------	-----------------------

¹ This equipment is outside the scope of the directive 2014/34/EU and must not carry a separate CE marking according to the directive as the equipment has no own ignition source.

Physical data

Material

Product wetted steel parts:	1.4401 (316L)
External surface finish:	Semi-bright (blasted)
Internal surface finish:	Ra ≤ 1,6 µm / ≤ 64 µinch
Optional:	Bright Polished Ra ≤ 0,8 µm / 32 µinch
Other steel parts:	1.4301 (304)
Product wetted seals:	EPDM (optional: NBR)
Other seals:	NBR

Valve body combination

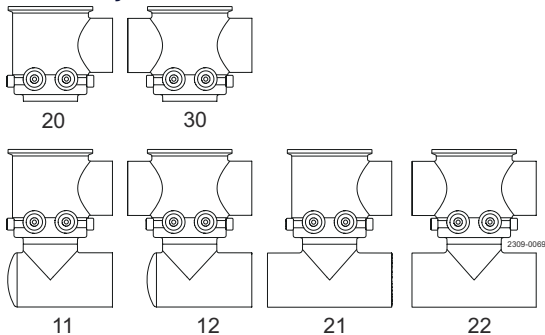

Type 20 and 30 body versions are on request available in following configurations:

- Tee welded on lower port in 0 or 90 deg. version. Type: 21 and 22
- Bend welded on lower port in 0, 90, 180 or 270 deg. version. Type: 11 and 12

Options

- Male parts or clamp liners in accordance with required standard.
- Control and Indication: ThinkTop V-Series
- Actuator with stronger spring.
- Larger actuator for valve sizes 1½"-2".
- CIP installation kits.
- Other valve body combinations.
- Service tools for actuator.
- Tool for plug seals (Necessary for changing the seals).



Note!

For further details, see also instruction manual ESE02255.

Air Consumption at 80 PSI

Size	1.5-inch - 2-inch	2.5-inch - 3-inch	5-inch - 6-inch
Shut-off valve - Actuator function	67.1 in ³	235.0 in ³	503.4 in ³
Shut-off valve - Actuator function			1208.2 in ³

Operation/cleaning

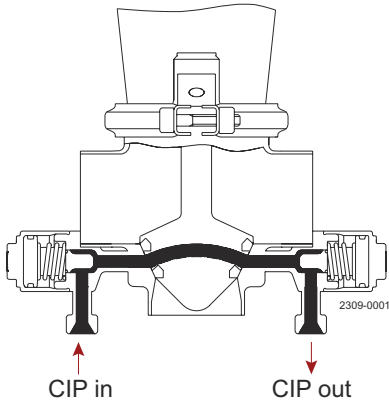

Figure 1. Closed shut-off valve: cleaning of the leakage chamber

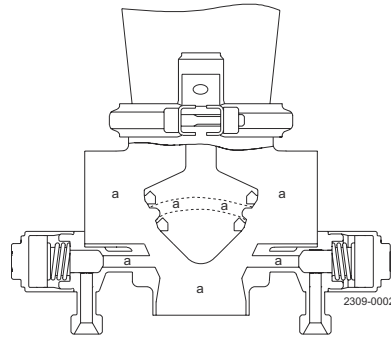
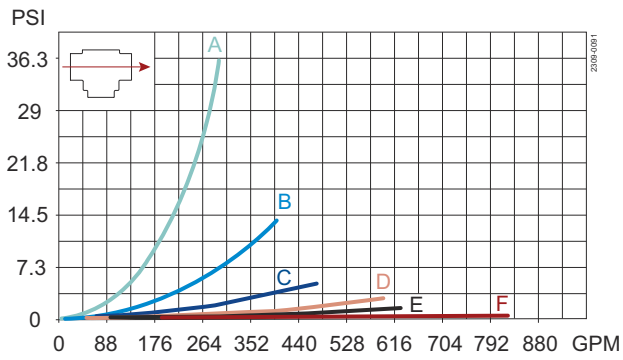

Figure 2. Open shut-off valve: cleaning of the valve body and the leakage chamber

Pressure drop/capacity diagrams

Shut-off valve:



- A = 1.5" / DN40
- B = 2" / DN50
- C = 2.5" / DN65
- D = 3" / DN80
- E = 4" / DN100
- F = DN125 / DN150

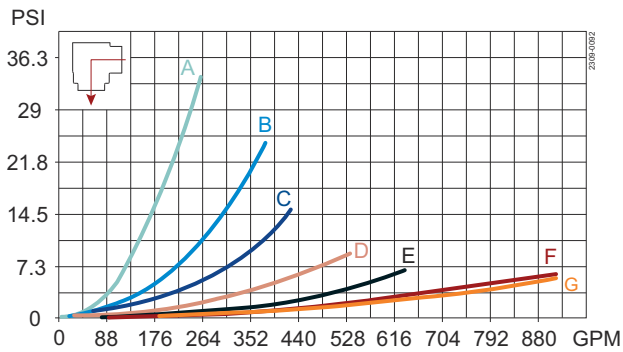

- A = 1.5" / DN40
- B = 2" / DN50
- C = 2.5" / DN65
- D = 3" / DN80
- E = 4" / DN100
- F = DN125
- G = DN150

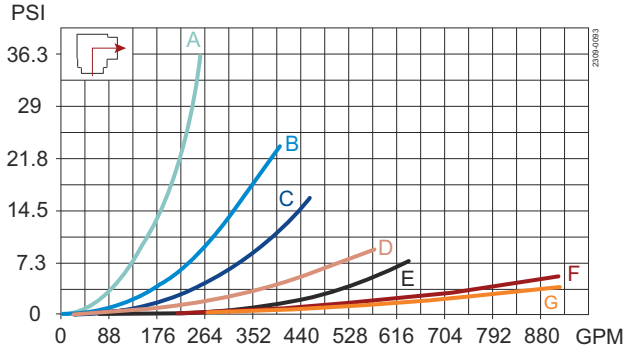

A = 1.5" / DN40 D = 3" / DN80
 B = 2" / DN50 E = 4" / DN100
 C = 2.5" / DN65 F = DN125
 G = DN150

Leakage chamber, pressure drop and flow velocity

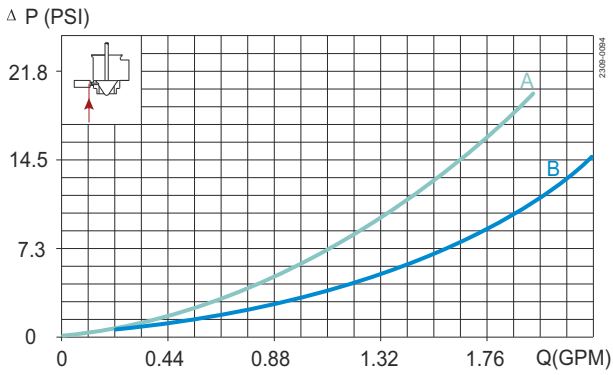

A = CIP / Detecting valve ø27
 B = CIP / Detecting valve ø32



Note!

For the diagrams the following applies:
 Medium: Water (68°F).
 Measurement: In accordance with VDI 2.

Max pressure difference/support air pressure diagrams

Upper plug max. product pressure without leakage, as a function of support air:

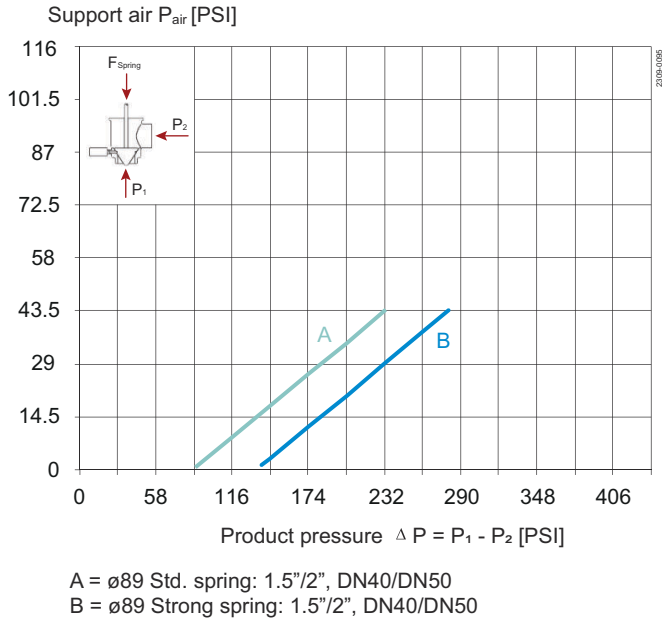

Figure 3. ø89 actuator

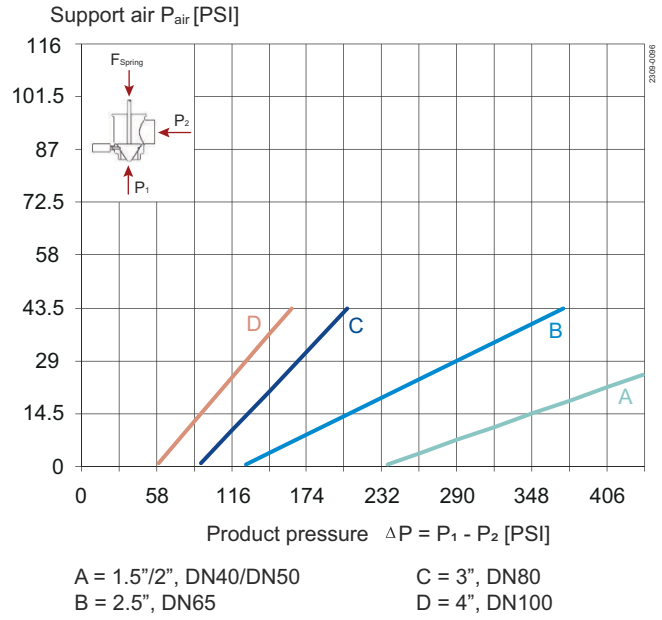

Figure 4. ø133 actuator with standard spring

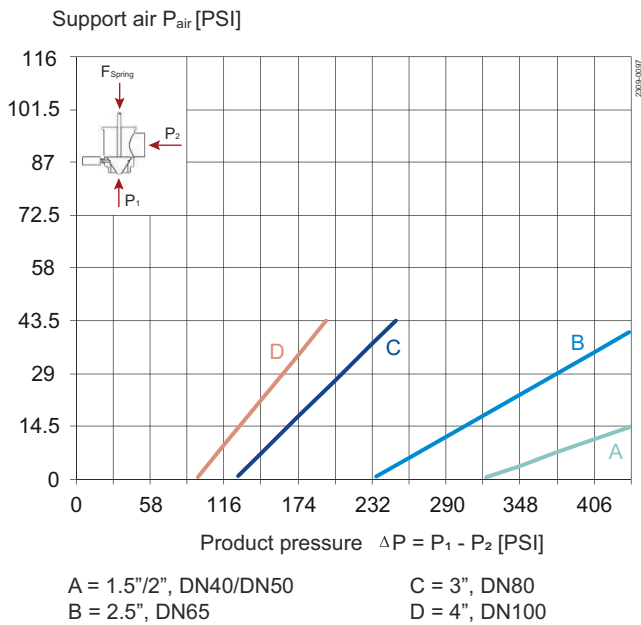

Figure 5. ø133 actuator with strong spring

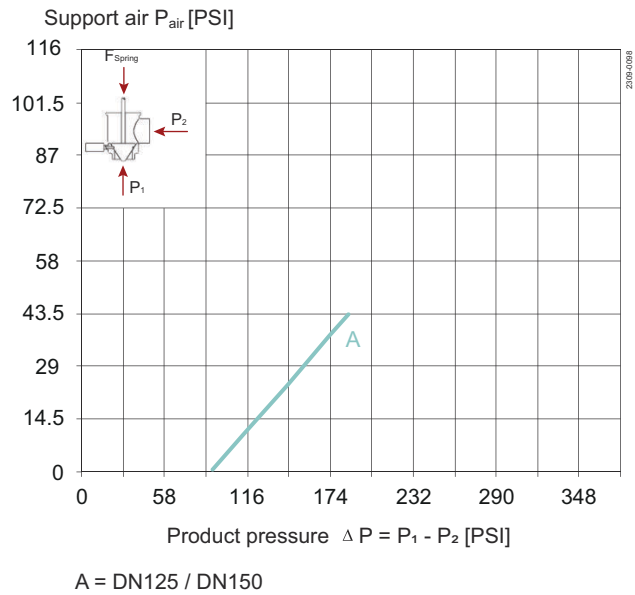

Figure 6. ø199 actuator

Upper plug max. product pressure against which the valve can open, as a function of air pressure:

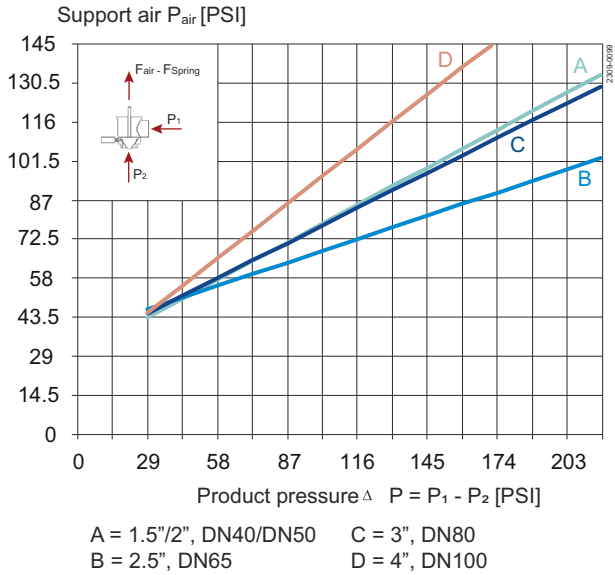

Figure 7. ø89 actuator with standard spring

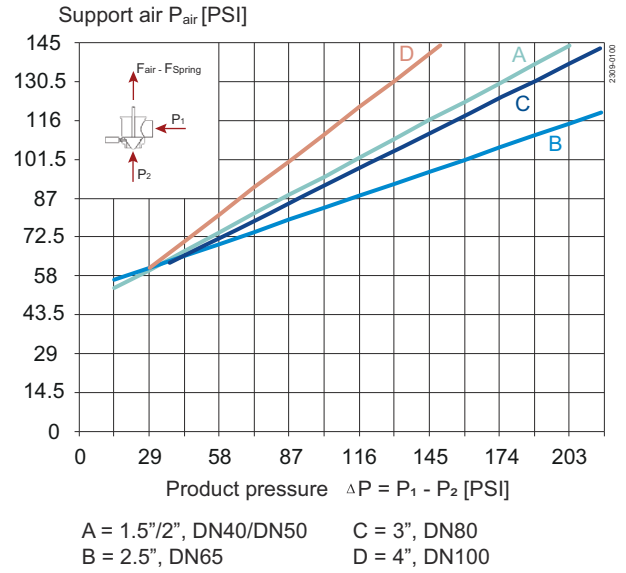

Figure 8. ø89 actuator with strong spring

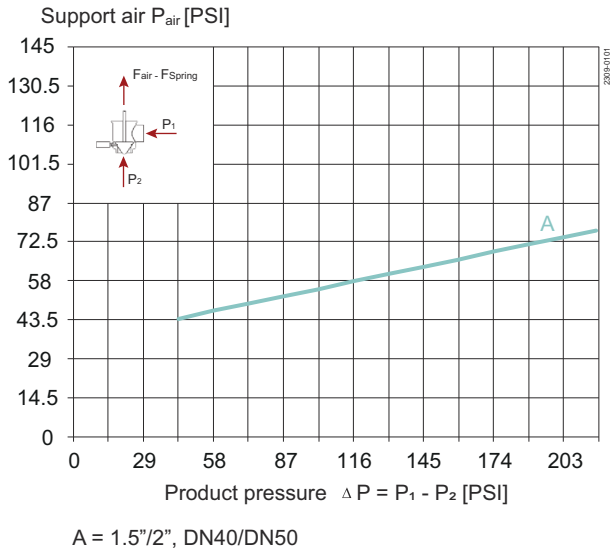

Figure 9. ø133 actuator with standard spring

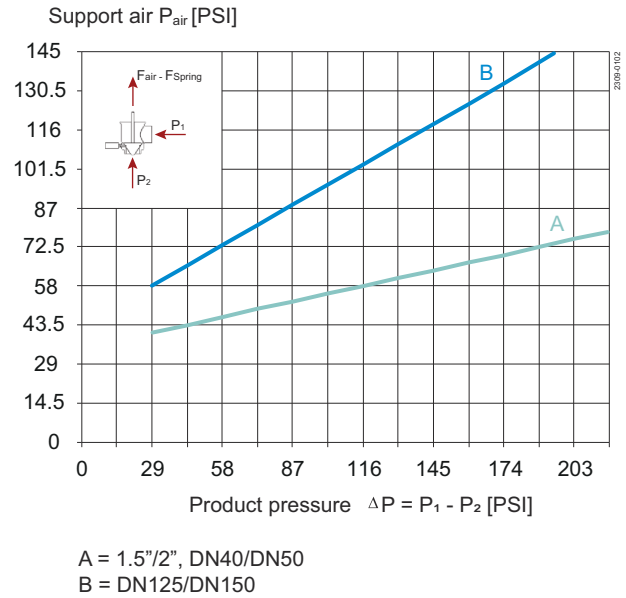

Figure 10. ø133 actuator with strong spring



Note!

If actuator is supported by air on spring side max allowable pressure is 345 PSI (3 bar).
 Air reduction valve: Alfa Laval item no. 9611995903 ensuring max 45 PSI support air.

CIP/detecting valves. Max. product pressure without leakage, as a function of air pressure:

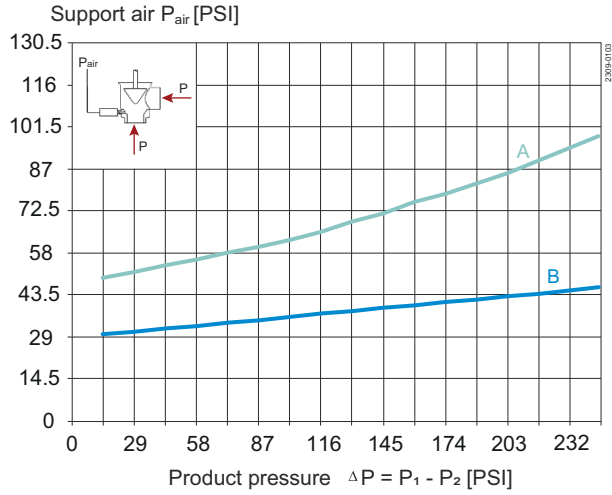

A = CIP valve $\varnothing 27$

B = CIP valve $\varnothing 32$

Max. CIP pressure in leakage chamber without leakage to product area, as a function of product pressure:

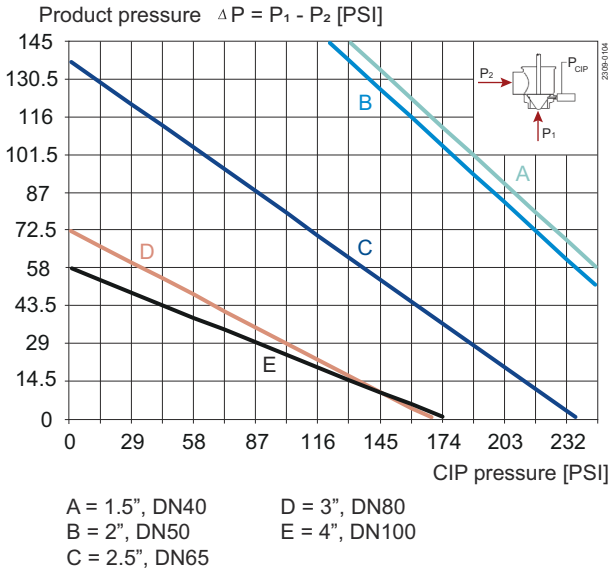

Figure 11. ø89 actuator with standard spring

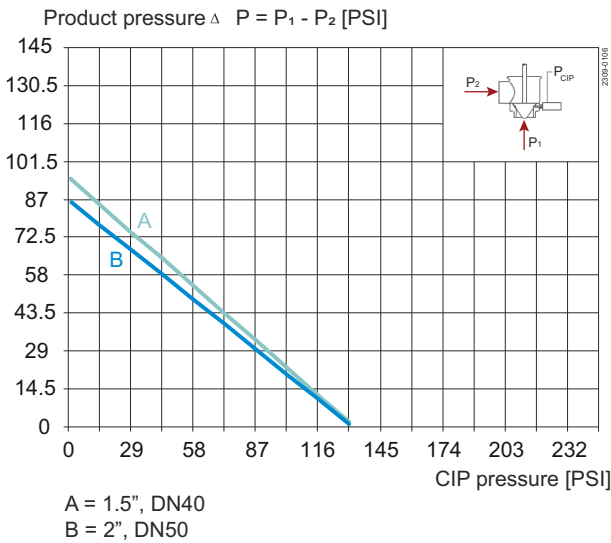

Figure 13. ø133 actuator with standard spring

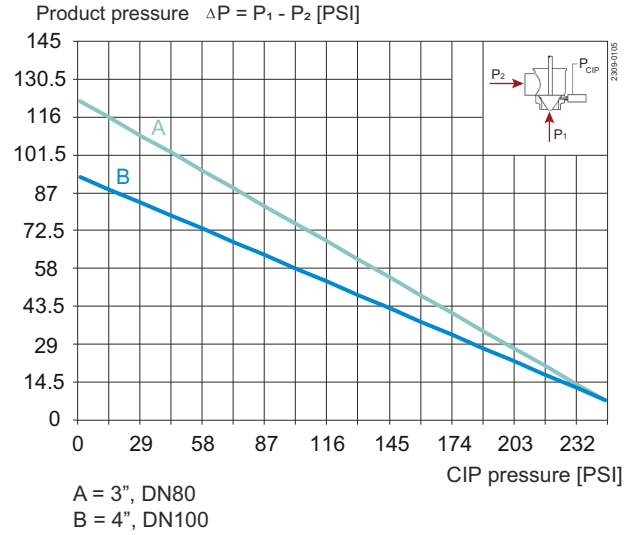

Figure 12. ø89 actuator with strong spring

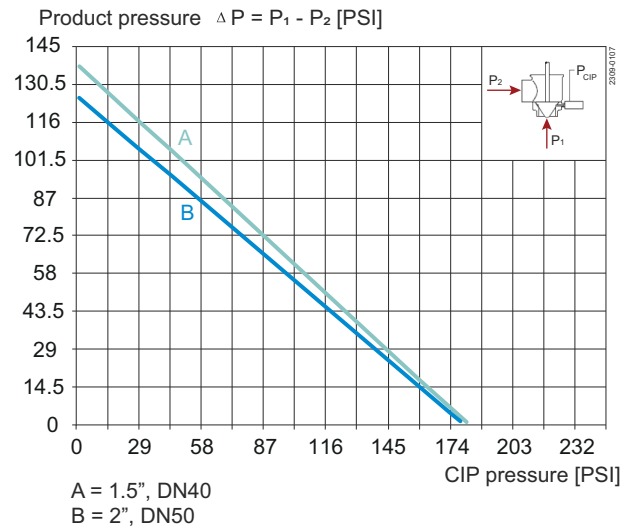

Figure 14. ø133 actuator with strong spring



Note!

If actuator is supported by air on spring side max allowable pressure is 345 PSI (3 bar).

Dimensions (inch)

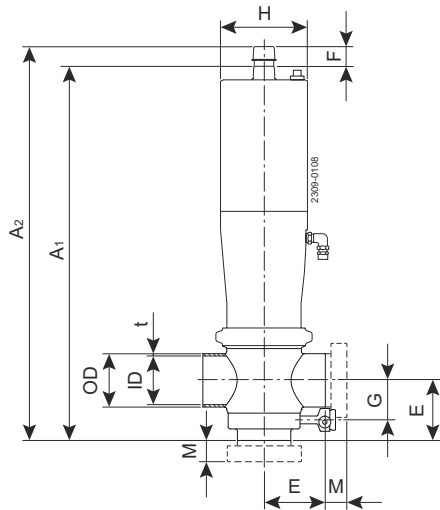

Figure 15. Shut-off valve with one valve body

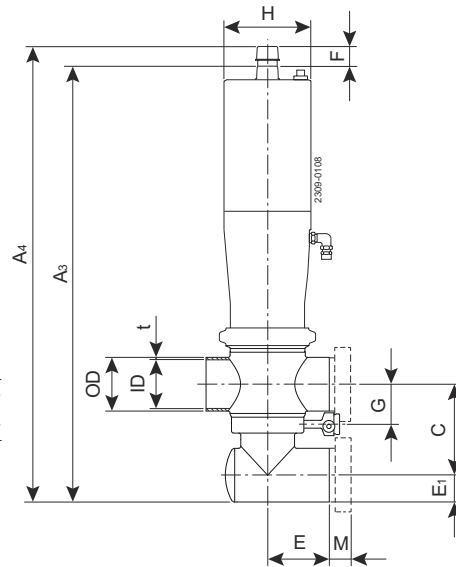
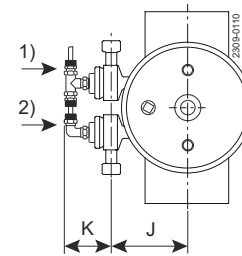

Figure 16. Shut-off valve with two valve bodies



- 1) CIP valve
- 2) Detecting valve

Figure 17. Top view

Size	1½"	2"	2½"	3"	4"	DN125	DN150
A1	13.58	13.98	17.05	17.91	20.75	21.06	23.00
A2	14.57	14.96	18.03	19.17	22.01	22.84	24.76
A3	16.27	16.61	20.00	21.10	24.06		
A4	17.26	17.60	21.26	22.36	25.32		
C	3.86	4.02	4.88	5.08	6.54		
C1	3.15	3.31	4.25	4.53	5.91		
OD	1.50	2.00	2.50	3.00	4.00	5.08	6.06
ID	1.37	1.87	2.37	2.84	3.84	4.92	5.91
t	0.06	0.06	0.06	0.08	0.08	0.08	0.08
E	1.95	2.42	3.24	3.44	5.26	5.91	5.91
E1	0.81	1.06	1.31	1.54	2.04		
F	0.98	0.98	1.26	1.26	1.26	1.93	1.93
G	1.06	1.31	1.56	1.80	2.30	2.83	3.33
H	3.50	3.50	5.24	5.24	5.24	7.83	7.83
J	1.84	1.84	2.24	2.62	3.32	3.92	3.92
K	2.48	2.48	2.48	2.48	2.48	2.30	2.30
Tri-Clamp®	0.83	0.83	0.83	0.83	0.83		
M/DIN male						1.81	1.97
Weight (lb.) Shut-off valve with one valve body	13.23	13.89	28.22	29.32	36.60	1.69	1.75
Weight (lb.) Shut-off valve with two valve bodies	15.65	16.13	31.31	35.05	47.18	95.68	98.11

Air Connections Compressed air:

R 1/8" (BSP), internal thread.

CIP connection:

R 3/8" (BSP), external thread.

Leakage connection:

R 3/8" (BSP), external thread.

Caution, opening/closing time:

Opening/closing time will be affected by the following:

- The air supply (air pressure).
- The length and dimensions of the air hoses.
- Number of valves connected to the same air hose.
- Use of single solenoid valve for serial connected air actuator functions.
- Product pressure.

This document and its contents are subject to copyrights and other intellectual property rights owned by Alfa Laval AB (publ) or any of its affiliates (jointly "Alfa Laval"). No part of this document may be copied, reproduced or transmitted in any form or by any means, or for any purpose, without Alfa Laval's prior express written permission. Information and services provided in this document are made as a benefit and service to the user, and no representations or warranties are made about the accuracy or suitability of this information and these services for any purpose. All rights are reserved.

200003998-6-EN-US

© Alfa Laval Corporate

How to contact Alfa Laval

Up-to-date Alfa Laval contact details for all countries are always available on our website at www.alfalaval.com