

COMMON FINISHES		
DESIGNATION	PROCESS CONTACT	NON-PROCESS CONTACT
-1	MILL	MILL
-7	32 RA	32 RA
-PL	20 RA	32 RA
-PO	20 RA EP	32 RA
-PM	15 RA EP	32 RA

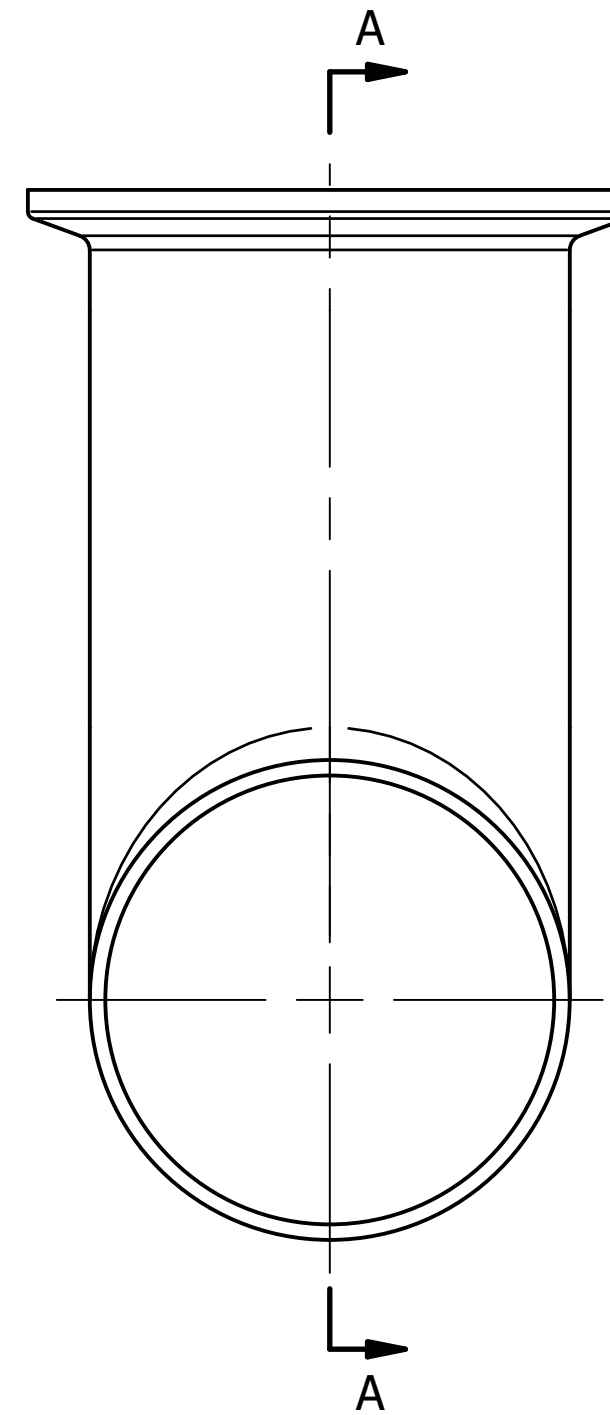

NOMINAL SIZE		A		B		C		D		OD		T1	
IN	MM	IN	MM	IN	MM	IN	MM	IN	MM	IN	MM	IN	MM
0.25	6.35	1.750	44.45	2.250	57.15	0.800	20.32	0.984	24.99	0.250	6.35	0.035	0.89
0.375	9.53	1.750	44.45	2.250	57.15	0.800	20.32	0.984	24.99	0.375	9.53	0.035	0.89
0.5	12.70	1.875	47.63	2.375	60.33	0.800	20.32	0.984	24.99	0.500	12.70	0.065	1.65
0.75	19.05	2.000	50.80	2.500	63.50	0.800	20.32	0.984	24.99	0.750	19.05	0.065	1.65
1	25.40	2.125	53.98	2.625	66.68	0.984	24.99	1.984	50.39	1.000	25.40	0.065	1.65
1.5	38.10	2.375	60.33	2.875	73.03	1.718	43.64	1.984	50.39	1.500	38.10	0.065	1.65
2	50.80	2.875	73.03	3.375	85.73	2.218	56.34	2.516	63.91	2.000	50.80	0.065	1.65
2.5	63.50	3.125	79.38	3.625	92.08	2.781	70.64	3.047	77.39	2.500	63.50	0.065	1.65
3	76.20	3.375	85.73	3.875	98.43	3.281	83.34	3.579	90.91	3.000	76.20	0.065	1.65
4	101.60	4.125	104.78	4.750	120.65	4.344	110.34	4.682	118.92	4.000	101.60	0.083	2.11
6	152.40	5.625	142.88	7.125	180.98	6.176	156.87	6.570	166.88	6.000	152.40	0.109	2.77

* INFORMATION PROVIDED IN THIS DRAWING IS FOR REFERENCE ONLY. FINISH AVAILABILITY DEPENDANT ON MATERIAL

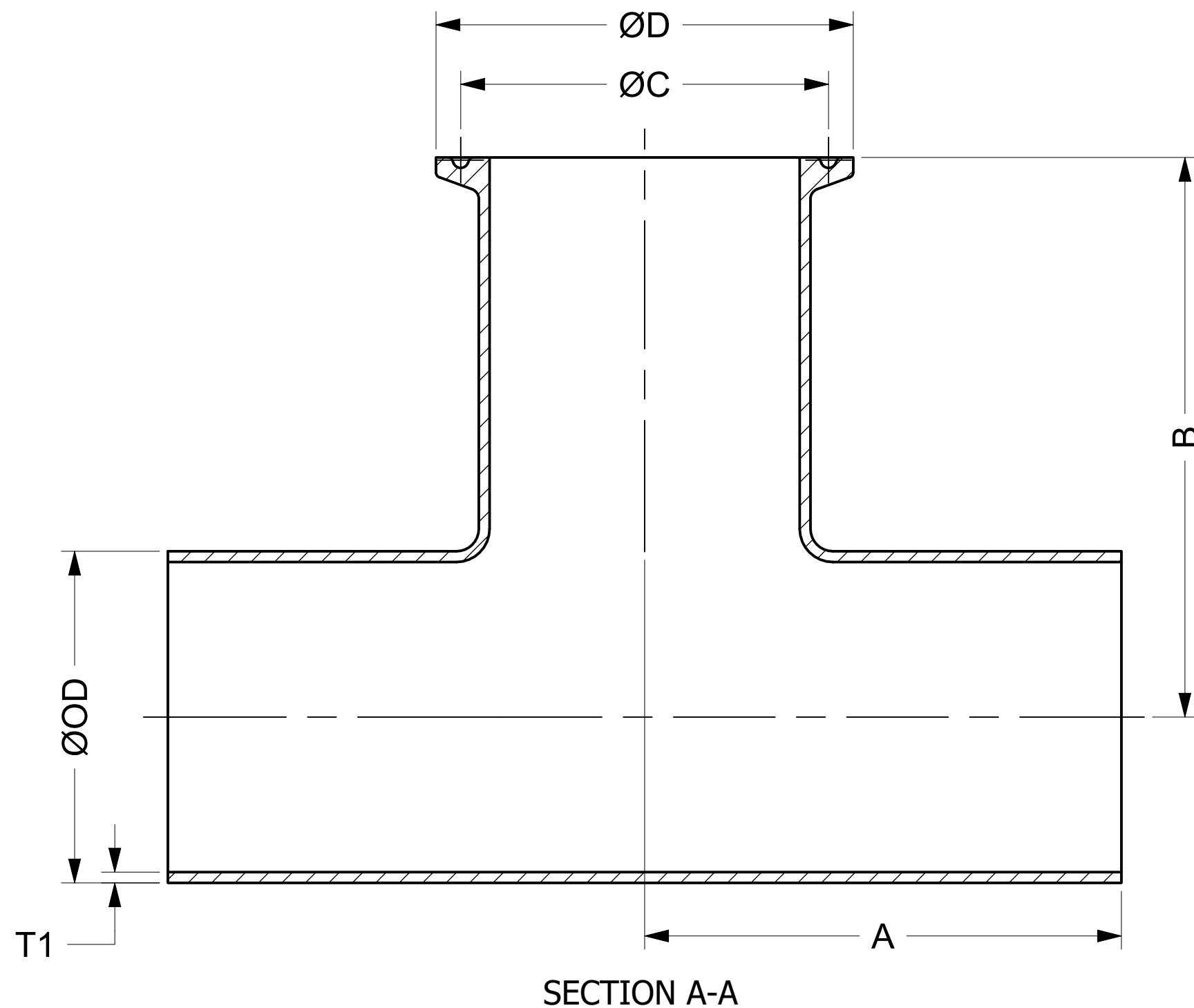
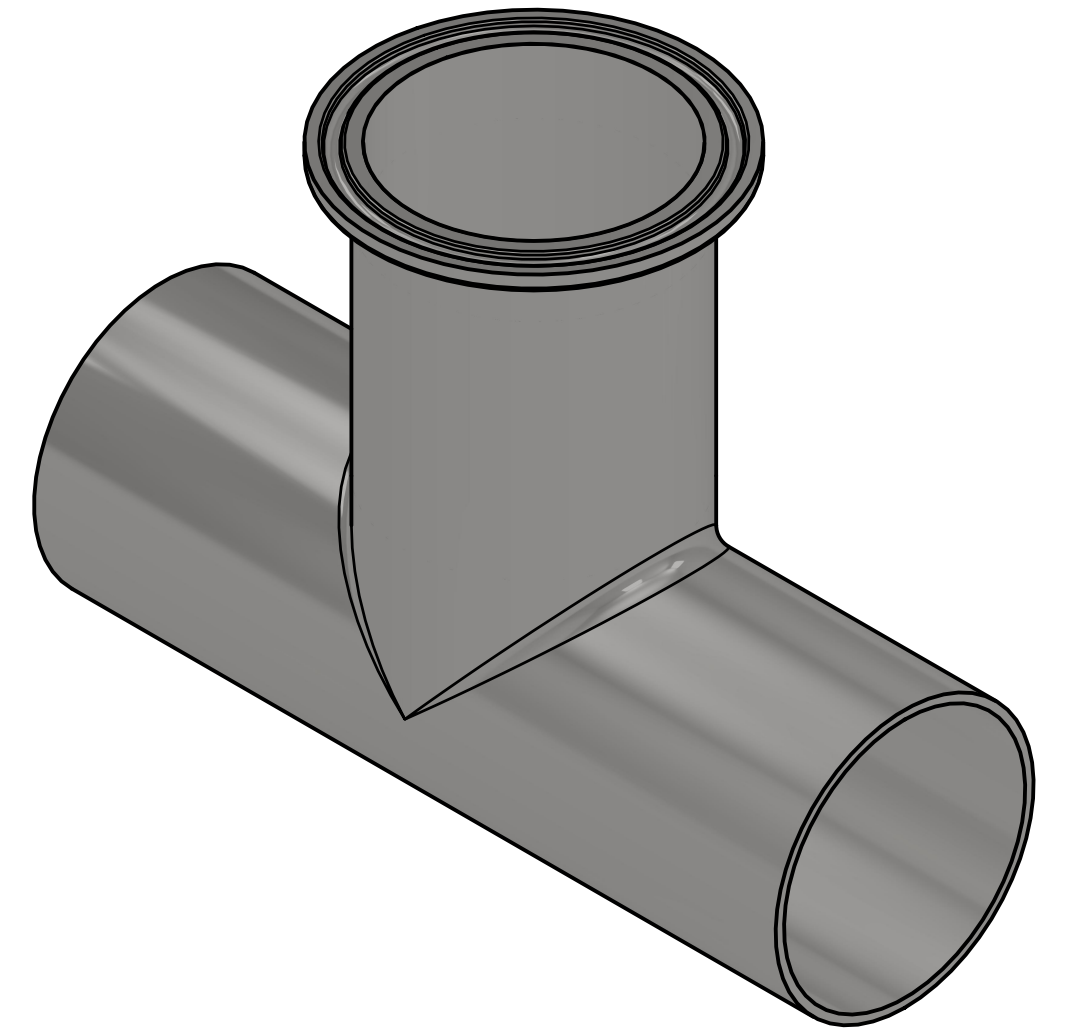

PART NO.:

B7WWM

DESCRIPTION:

**TEE, BW RUN X TC
BRANCH**

MATERIAL OPTIONS:

304/304L SS

316/316L SS

AL-6XN® - N08367

HASTELLOY® C-22® - N06022

DWG NO.

CDB7WWM

CREATION DATE

03NOV2025

SHEET

1 OF 1

REV.

-