

COMMON FINISHES		
DESIGNATION	PROCESS CONTACT	NON-PROCESS CONTACT
-1	MILL	MILL
-7	32 RA	32 RA
-PL	20 RA	32 RA
-PO	20 RA EP	32 RA
-PM	15 RA EP	32 RA

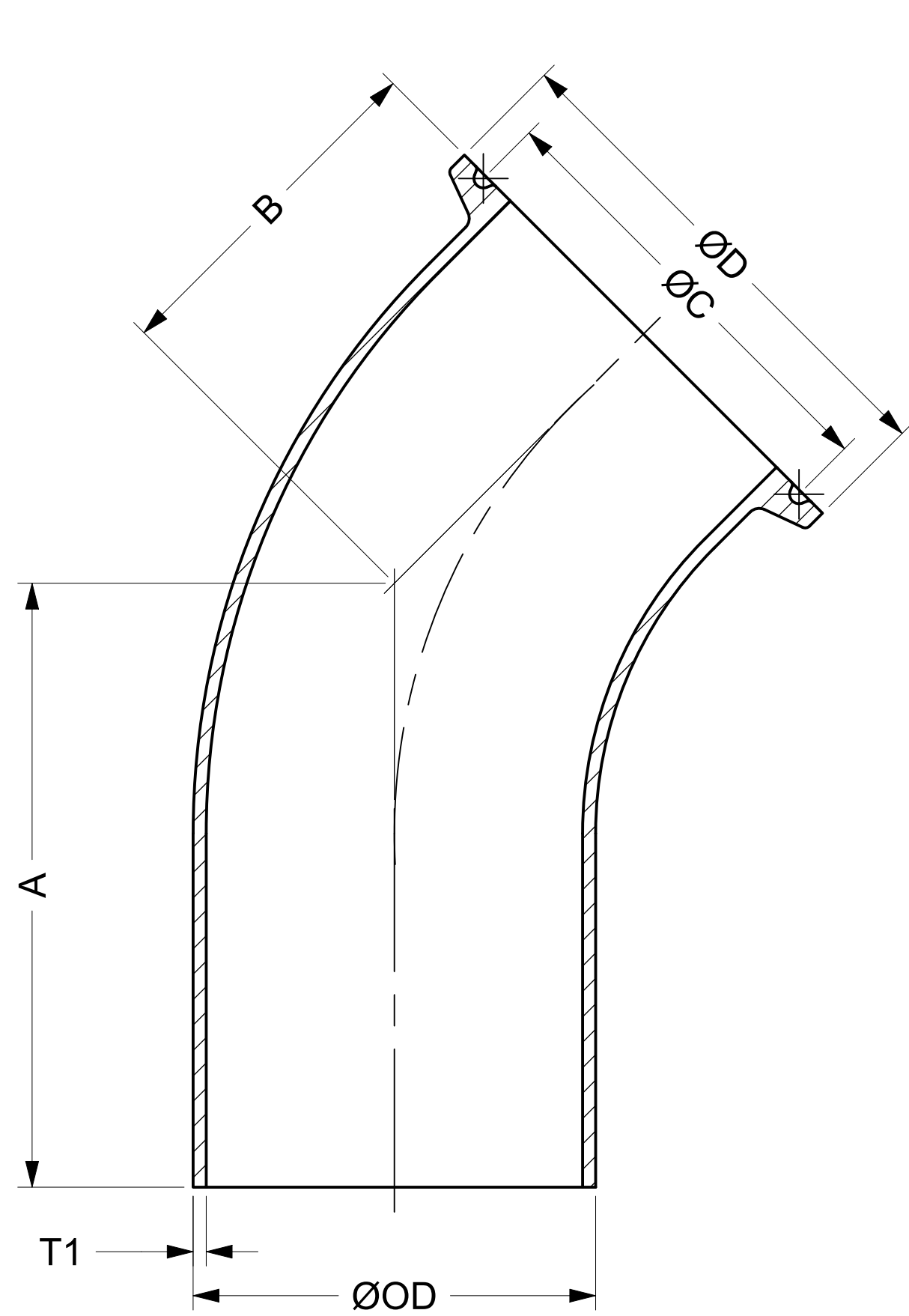

SECTION A-A

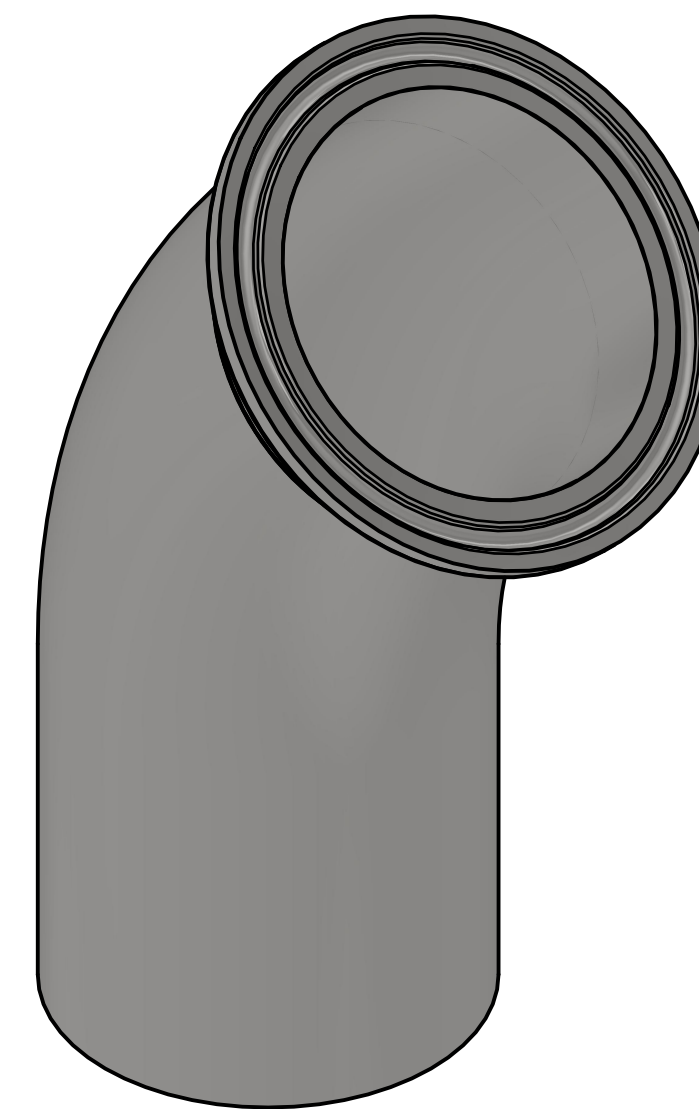
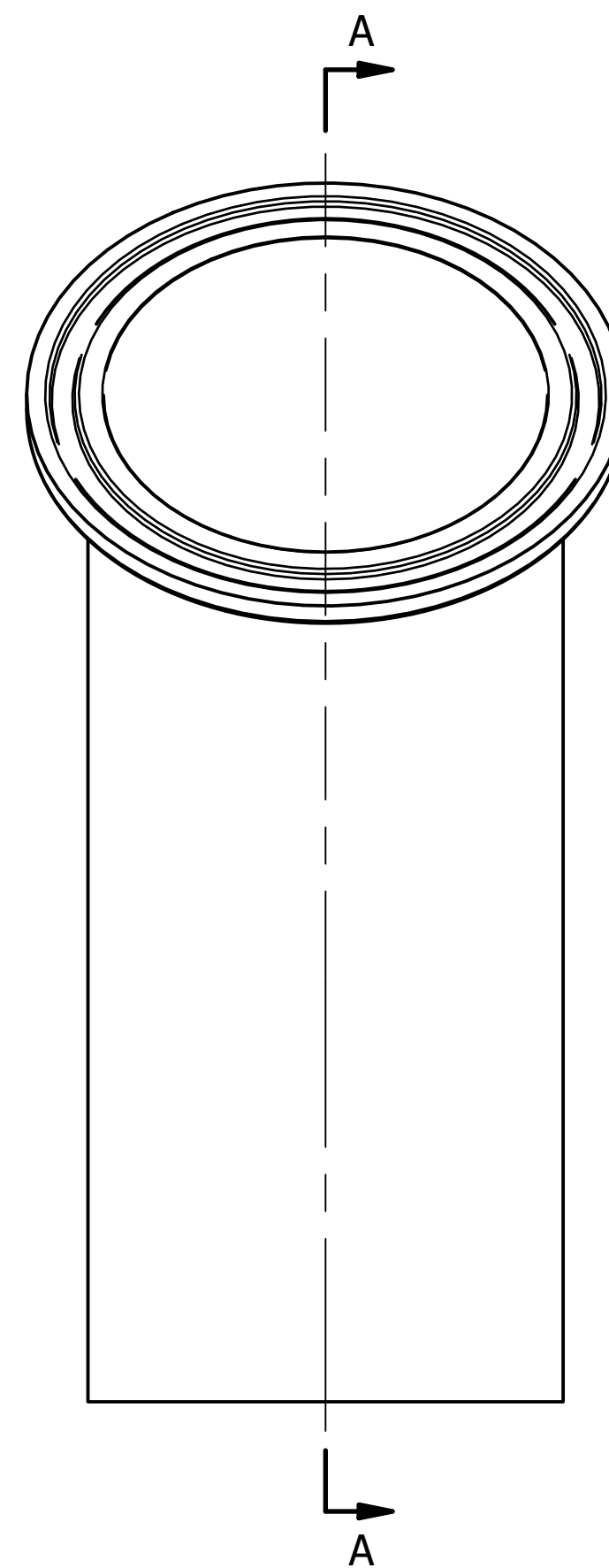

NOMINAL SIZE		A		B		C		D		OD		T1	
IN	MM	IN	MM	IN	MM	IN	MM	IN	MM	IN	MM	IN	MM
0.25	6.35	2.000	50.80	1.000	25.40	0.800	20.32	0.984	24.99	0.250	6.35	0.035	0.89
0.375	9.53	2.000	50.80	1.000	25.40	0.800	20.32	0.984	24.99	0.375	9.53	0.035	0.89
0.5	12.70	2.250	57.15	1.000	25.40	0.800	20.32	0.984	24.99	0.500	12.70	0.065	1.65
0.75	19.05	2.250	57.15	1.000	25.40	0.800	20.32	0.984	24.99	0.750	19.05	0.065	1.65
1	25.40	2.250	57.15	1.125	28.58	1.718	43.64	1.984	50.39	1.000	25.40	0.065	1.65
1.5	38.10	2.500	63.50	1.438	36.53	1.718	43.64	1.984	50.39	1.500	38.10	0.065	1.65
2	50.80	3.000	76.20	1.750	44.45	2.218	56.34	2.516	63.91	2.000	50.80	0.065	1.65
2.5	63.50	3.375	85.73	2.063	52.40	2.781	70.64	3.047	77.39	2.500	63.50	0.065	1.65
3	76.20	3.625	92.08	2.375	60.33	3.281	83.34	3.579	90.91	3.000	76.20	0.065	1.65
4	101.60	4.500	114.30	3.125	79.38	4.344	110.34	4.682	118.92	4.000	101.60	0.083	2.11
6	152.40	6.250	158.75	5.250	133.35	6.176	156.87	6.570	166.88	6.000	152.40	0.109	2.77

\* INFORMATION PROVIDED IN THIS DRAWING IS FOR REFERENCE ONLY. FINISH AVAILABILITY DEPENDANT ON MATERIAL



PART NO.:

B2KMW

DESCRIPTION:

45 DEGREE ELBOW, TC X  
BW

MATERIAL OPTIONS:

304/304L SS

316/316L SS

AL-6XN® - N08367

HASTELLOY® C-22® - N06022

DWG NO.

CDB2KMW

CREATION DATE

16SEP2025

SHEET

1 OF 1

REV.

-